

PRELIMINARY

Video Signal Switcher

OVERVIEW

The AA7600SP is video switching ICs. Each contains three two-channel analog multiplexers. It has internal clamp function and so is applied to fixed DC level of video signal.

FEATURES

- Operating supply voltage: 5 V
- Three 2-input / 1-output switches.
- Wide output frequency range: (1 kHz to 8MHz, 0dB Typical).
- Wide dynamic range (2.9 Vp-p Typical.)
- Low power consumption

PIN Configuration

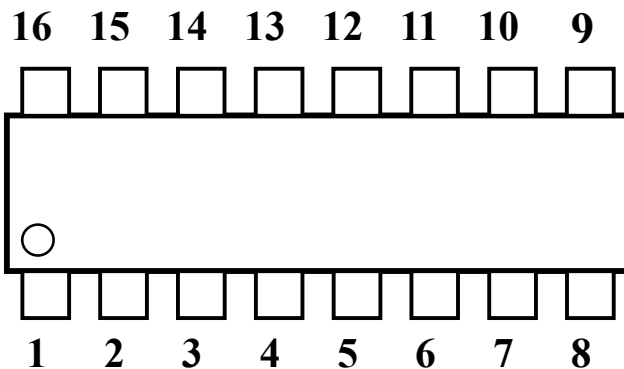

PIN DESCRIPTIONS

Pin No.	Symbol	I/O	Description	Pin No.	Symbol	I/O	Description
1	IN2a	V	A Block input pin2	9	IN1c	V	C Block input pin1
2	CTLa	V	A Block control pin	10	GND	—	Ground pin
3	OUTa	O	A Block Output pin	11	IN1b	V	B Block input pin1
4	GND	—	Ground pin	12	CTLb	V	B Block control pin
5	OUTb	O	B Block Output pin	13	VCC	—	IC power supply pin
6	OUTc	O	C Block Output pin	14	IN2b	V	B Block input pin2
7	CTLc	V	C Block control pin	15	GND	—	Ground pin
8	IN2c	V	C Block input pin2	16	IN1a	V	A Block input pin1

PRELIMINARY

Video Signal Switcher

APPLICATIONS

- Televisions
- VCR

Block diagram

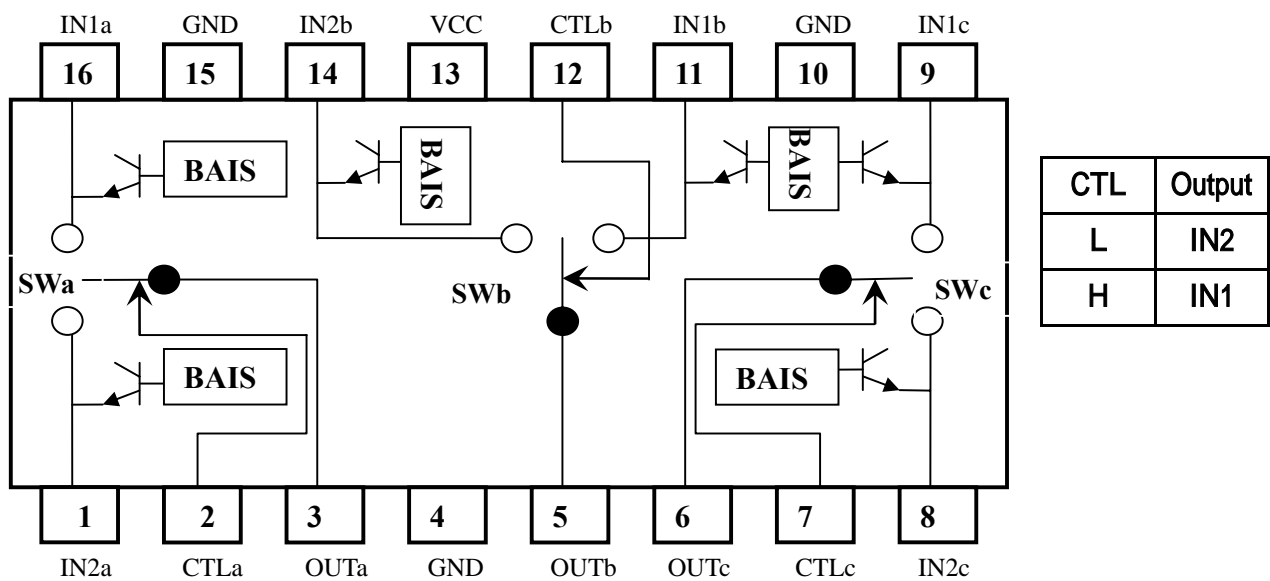

Absolute maximum ratings (Ta = 25 °C)

Parameter	Symbol	Limits	Unit
Power supply voltage	V _{CC}	10	V
Power dissipation	P _d	500	mW
Operating temperature	T _{opr}	-40 - +85	
Storage temperature	T _{stg}	-55 - +125	

PRELIMINARY

Video Signal Switcher

ELECTRICAL CHARACTERISTICS

Parameter	Symbol	Condition	Min	Typ.	Max	Unit
Power supply voltage	Vcc	—	4.5	5	5.5	V
Supply current	Icc	—	—	12.5	20	mA
Maximum output level	Vom	f = 1kHz, THD = 0.5%	2.7	2.9	—	Vp-p
Voltage gain	Gv	f = 1MHz, VIN = 1Vp-p	-0.5	0	0.5	dB
Frequency characteristics	Gf	10MHz / 1MHz, V = 1Vp-p	-3	0	1	dB
CTL pin switch level	VTH	—	2.6	2.8	3.1	V

Reference data

DC voltages (reference values) Vcc = 5V, 25			
Units: V			
Pin No.	DC voltage	Pin No.	DC voltage
1	1.98	9	1.97
2	4.63	10	0
3	0.57	11	1.96
4	0	12	4.63
5	0.57	13	0
6	0.57	14	4.96
7	4.63	15	0
8	1.97	16	1.98

PRELIMINARY

Video Signal Switcher

Measurement circuit

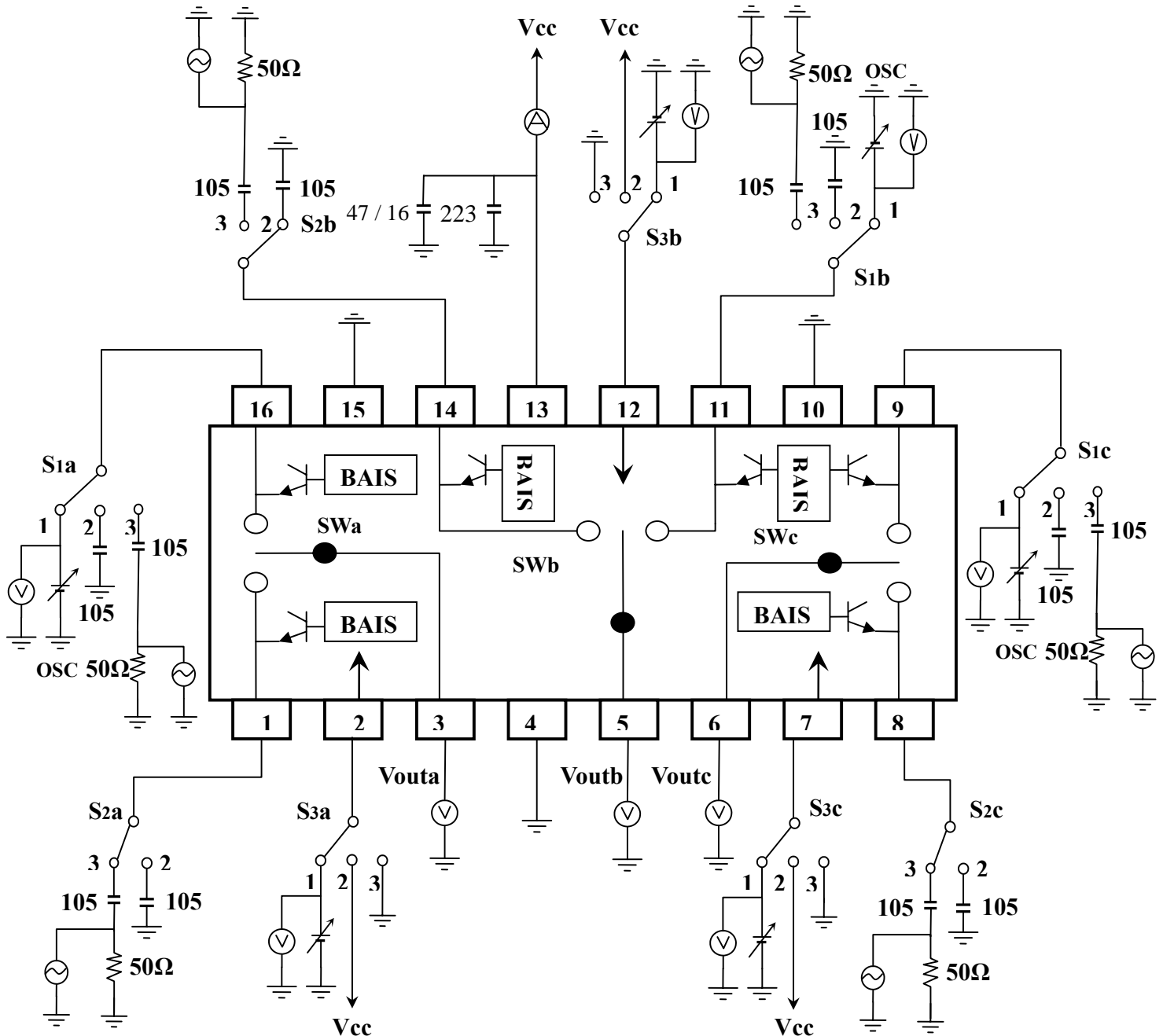

PRELIMINARY

Video Signal Switcher

Measurement conditions

Parameter		Symbol	Switch settings								
			S1a	S2a	S3a	S1b	S2b	S3b	S1c	S2c	S3c
Maximum output level (Note 1)	I _{N1a}	V _{om}	3	2	2	—	—	—	—	—	—
	I _{N2a}	V _{om}	2	3	3	—	—	—	—	—	—
	I _{N1b}	V _{om}	—	—	—	3	2	2	—	—	—
	I _{N2b}	V _{om}	—	—	—	2	3	3	—	—	—
	I _{N1c}	V _{om}	—	—	—	—	—	—	3	2	2
	I _{N2c}	V _{om}	—	—	—	—	—	—	2	3	3
Voltage gain (Note 2)	I _{N1a}	G _v	3	2	2	—	—	—	—	—	—
	I _{N2a}	G _v	2	3	3	—	—	—	—	—	—
	I _{N1b}	G _v	—	—	—	3	2	2	—	—	—
	I _{N2b}	G _v	—	—	—	2	3	3	—	—	—
	I _{N1c}	G _v	—	—	—	—	—	—	3	2	2
	I _{N2c}	G _v	—	—	—	—	—	—	2	3	3
Frequency characteristic (Note 3)	I _{N1a}	G _f	3	2	2	—	—	—	—	—	—
	I _{N2a}	G _f	2	3	3	—	—	—	—	—	—
	I _{N1b}	G _f	—	—	—	3	2	2	—	—	—
	I _{N2b}	G _f	—	—	—	2	3	3	—	—	—
	I _{N1c}	G _f	—	—	—	—	—	—	3	2	2
	I _{N2c}	G _f	—	—	—	—	—	—	2	3	3
CTL pin switching level (Note 4)	CTL _a	V _{TH}	1	2	1	—	—	—	—	—	—
	CTL _b	V _{TH}	—	—	—	1	2	1	—	—	—
	CTL _c	V _{TH}	—	—	—	—	—	—	1	2	1

Note 1 : Input a f = 1kHz sine wave. This output voltage is the maximum output level V_{om} (V_{p-p})

Note 2 : Input a 1V_{p-p}, 1MHz sine wave. G_v = 20 log (V_{out} / V_{in}).

Note 3 : Input a 1V_{p-p}, 8MHz sine wave. G_f = 20 log (V_{out} (f = 10MHz) / V_{out} (f = 1MHz)).

Note 4 : Input a 1V_{p-p}, 1MHz sine wave

AA7600SP - 16-pin Plastic SOP

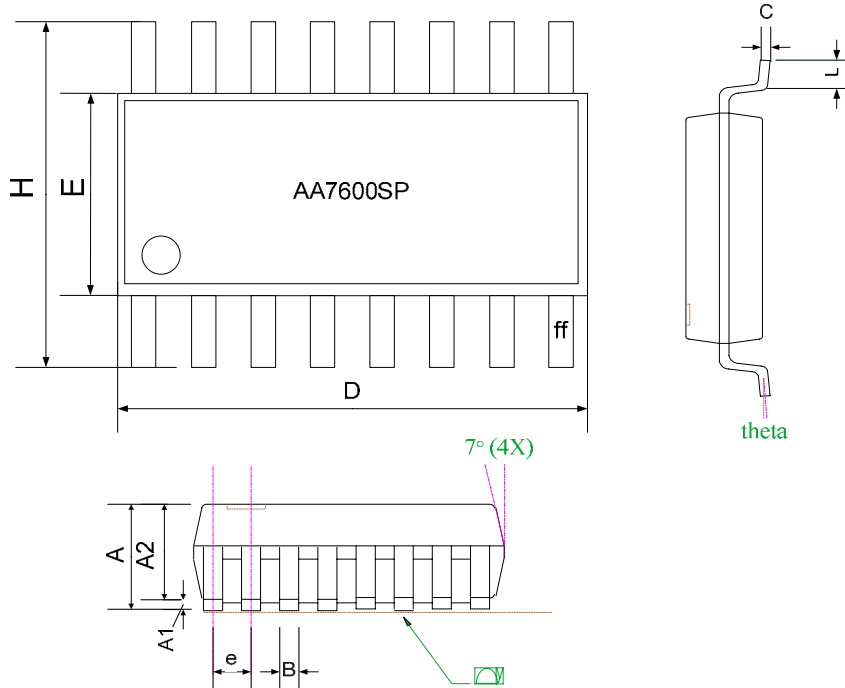

SYMBOLS	DIMENSIONS IN MILLIMETERS			DIMENSIONS IN INCHES		
	MIN	NOM	MAX	MIN	NOM	MAX
A	1.35	1.60	1.75	0.053	0.063	0.069
A1	0.10	---	0.25	0.004	---	0.010
A2	---	1.45	---	---	0.057	---
B	0.33	---	0.51	0.013	---	0.020
C	0.19	---	0.25	0.007	---	0.010
D	9.80	---	10.00	0.386	---	0.394
E	3.80	---	4.00	0.150	---	0.157
e	---	1.27	---	---	0.050	---
H	5.80	---	6.20	0.228	---	0.244
L	0.40	---	1.27	0.016	---	0.050
y	---	---	0.10	---	---	0.004
theta	0°	---	8°	0°	---	8°

NOTE

1. PACKAGE BODY SIZES EXCLUDE MOLD FLASH AND GATE BURRS
2. DIMENSION L IS MEASURED IN GAGE PLANE
3. TOLERANCE +/- 0.1 mm UNLESS OTHERWISE SPECIFIED
4. CONTROLLING DIMENSION IS MILLIMETER. CONVERTED INCH DIMENSIONS ARE NOT NECESSARILY EXACT.
5. FOLLOWED FROM JEDEC MS-012