

## FEATURES

- -55°C to +125°C operation
- 50 dB minimum attenuation at 500 kHz
- Compliant to MIL-STD-461C, CE03
- Compatible with MIL-STD-704E DC power bus

# EMI INPUT FILTER

## 28 VOLT INPUT



Size (max.): 0.980 x 0.805 x 0.270 (24.89 x 20.45 x 6.86 mm)

Case A1

Weight: 10.3 grams typical, 11.5 grams maximum

Screening: Standard, ES, or 883 (Class H)

## FMSA EMI FILTER

### 0.8 AMP

MODEL	
FMSA-461	0.8 amp

## DESCRIPTION

The FMSA-461 EMI filter module has been designed as a companion for Interpoint MSA flyback power converters. Multiple MSA power converters can be operated from a single filter provided the total power line current does not exceed the filter maximum rating. The FMSA filter will reduce the MSA's power line reflected ripple current to within the limit of MIL-STD-461C, Method CE03, as shown in the example of Figures 4 and 5.

The FMSA is fabricated using thick film hybrid technology and is sealed in a metal package for military, aerospace and other applications requiring EMI suppression. The filter uses only ceramic capacitors for reliable high temperature operation.

## OPERATION

The MSA power converter has an internal 2  $\mu$ F capacitor across its input power terminals. When the MSA and FMSA filters are used together, this capacitor becomes part of the filter and forms its final LC output section. When 2 or 3 MSAs are used with a single filter, this capacitor becomes 4  $\mu$ F or 6  $\mu$ F respectively, rather than 2  $\mu$ F, improving the rejection vs. frequency.

The FMSA filter can also be used with other types of Interpoint power converters (MHF, MHF+, MHE, MHD, and DCH series) to comply with CE03. For MHF, MHF+, MHD, and MHE models, the converter has an LC type line filter such that an inductor is seen looking into its positive input terminal. For these converters, it is necessary to terminate the filter with a capacitor to insure unconditionally stable operation. A capacitor across the filter output terminals of greater than 4 $\mu$ F or the optional damping circuit shown on the connection diagram will be adequate for stable operation. No capacitor is required for MSA, or DCH models.

## OPTIONAL DAMPING CIRCUIT

The optional damping circuit (Figure 2) can be used to prevent filter overshoot caused by MIL-STD-704A 80 V, or other, transients having rise times of less than 200  $\mu$ Sec. This damping can be alternately provided with a 1.50  $\Omega$  resistor in series with the filter positive input where the additional line loss can be tolerated. For transients with rise times of greater than 200  $\mu$ sec, there is no overshoot and the damping circuit is not required.

## LAYOUT REQUIREMENTS

The case of the filter must be connected to the case of the converter through a low impedance connection to minimize EMI.

# FMSA EMI FILTER

## 0.8 AMP

# EMI INPUT FILTERS

### ABSOLUTE MAXIMUM RATINGS

- Input Voltage**
- 0 to 40 VDC continuous
  - 80 V for 100 ms transient
- Lead Soldering Temperature (10 sec per lead)**
- 300°C
- Storage Temperature Range (Case)**
- -65°C to +150°C

### RECOMMENDED OPERATING CONDITIONS

- Input Voltage Range**
- 16 to 40 VDC continuous
- Case Operating Temperature (Tc)**
- -55°C to +125°C full power
- Derating Input/Output Current**
- Derate linearly from 100% at 100°C to 0.60 amps at 125°C case. Above 125°C derate to 0%.

### TYPICAL CHARACTERISTICS

- Capacitance**
- 0.045  $\mu\text{F}$  max, any pin to case
- Isolation**
- 100 megohm minimum at 500 V
  - Any pin to case, except case pin

Electrical Characteristics: 25°C Tc, nominal Vin, unless otherwise specified.

PARAMETER	CONDITIONS	FMSA-461			UNITS
		MIN	TYP	MAX	
INPUT VOLTAGE	CONTINUOUS	0	28	40	VDC
	TRANSIENT, 100 ms	—	—	80	V
INPUT CURRENT		—	—	0.80	A
DIFFERENTIAL MODE NOISE REJECTION	200 kHz	40	—	—	dB
	500 kHz TO 50 MHz	60	—	—	
COMMON MODE NOISE REJECTION	2 MHz - 50 MHz	40	—	—	dB
	DC RESISTANCE (R <sub>DC</sub> )	TC = 25°C	—	1.2	
OUTPUT VOLTAGE	STEADY STATE	$V_{OUT} = V_{IN} - I_{IN} (R_{DC})$			VDC
OUTPUT CURRENT	STEADY STATE (<100°C CASE)	—	—	0.80	A
INTERNAL POWER DISSIPATION	MAXIMUM CURRENT	—	—	0.96	W

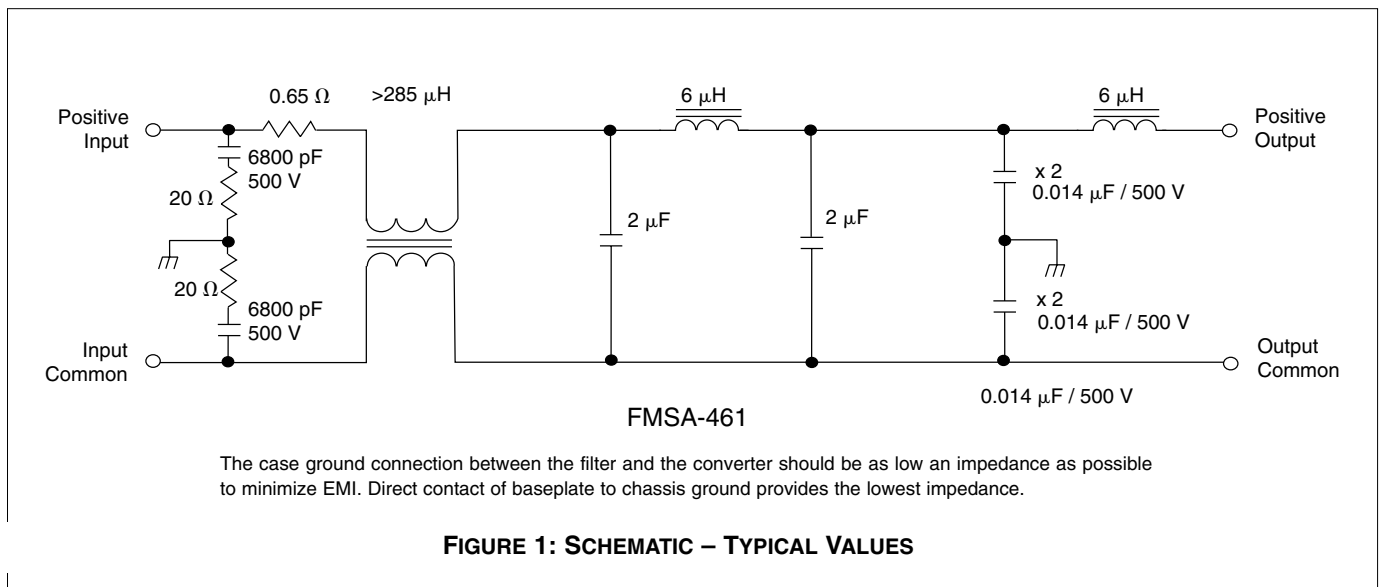
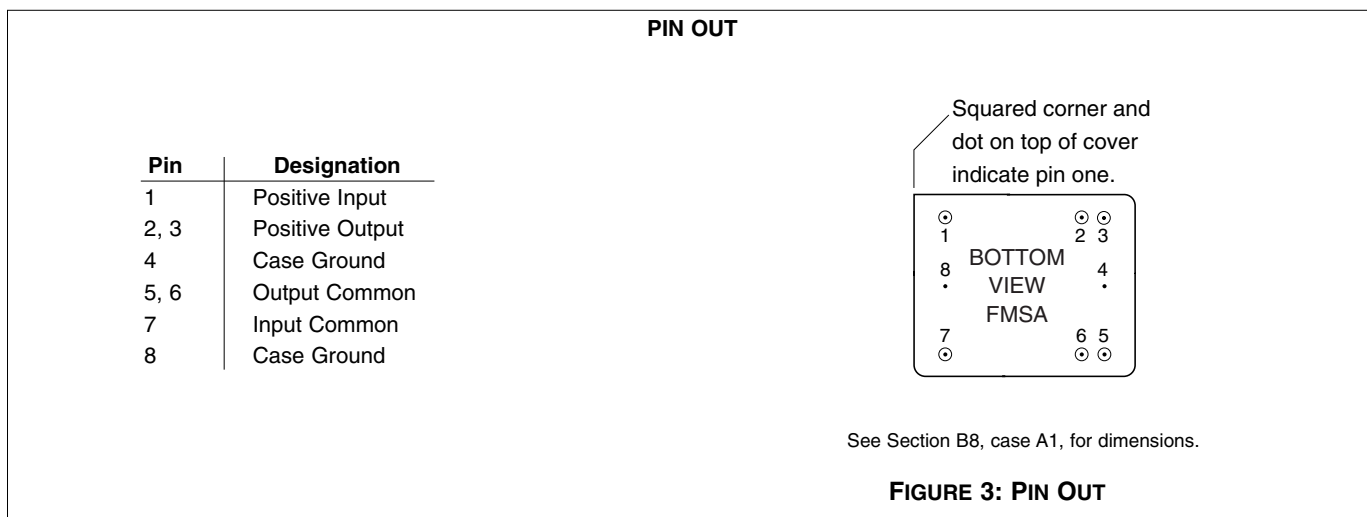
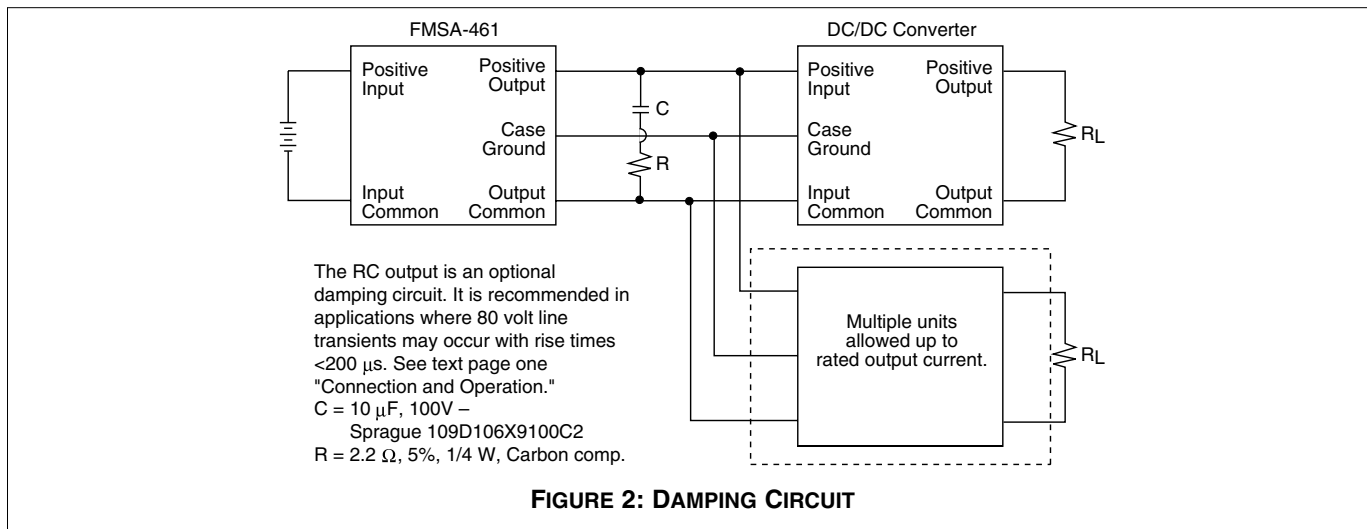
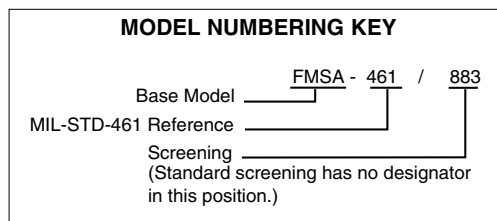

FIGURE 1: SCHEMATIC – TYPICAL VALUES



DSCC NUMBER	
DSCC DRAWING (5915)	FMSA-461 FILTER SIMILAR PART
96003-01HXC	FMSA-461/883

For exact specifications for a DSCC product, refer to the DSCC drawing. See Section A3, "SMD/DSCC Lists", for more information.



# FMSA EMI FILTER 0.8 AMP

# EMI INPUT FILTERS

Typical Performance Curves: 25°C Tc , nominal Vin, unless otherwise specified.

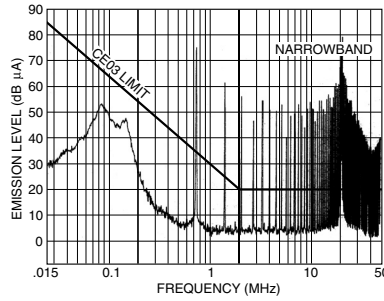

MSA2805S converter without a filter.

FIGURE 4

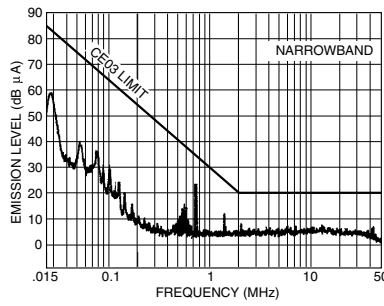

MSA2805S converters at full load with an FMSA-461 EMI filter

FIGURE 5

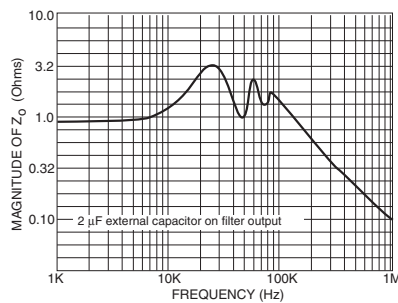

Typical Output Impedance (Z)  
With Input Shorted  
FMSA-461 EMI Filter

FIGURE 6

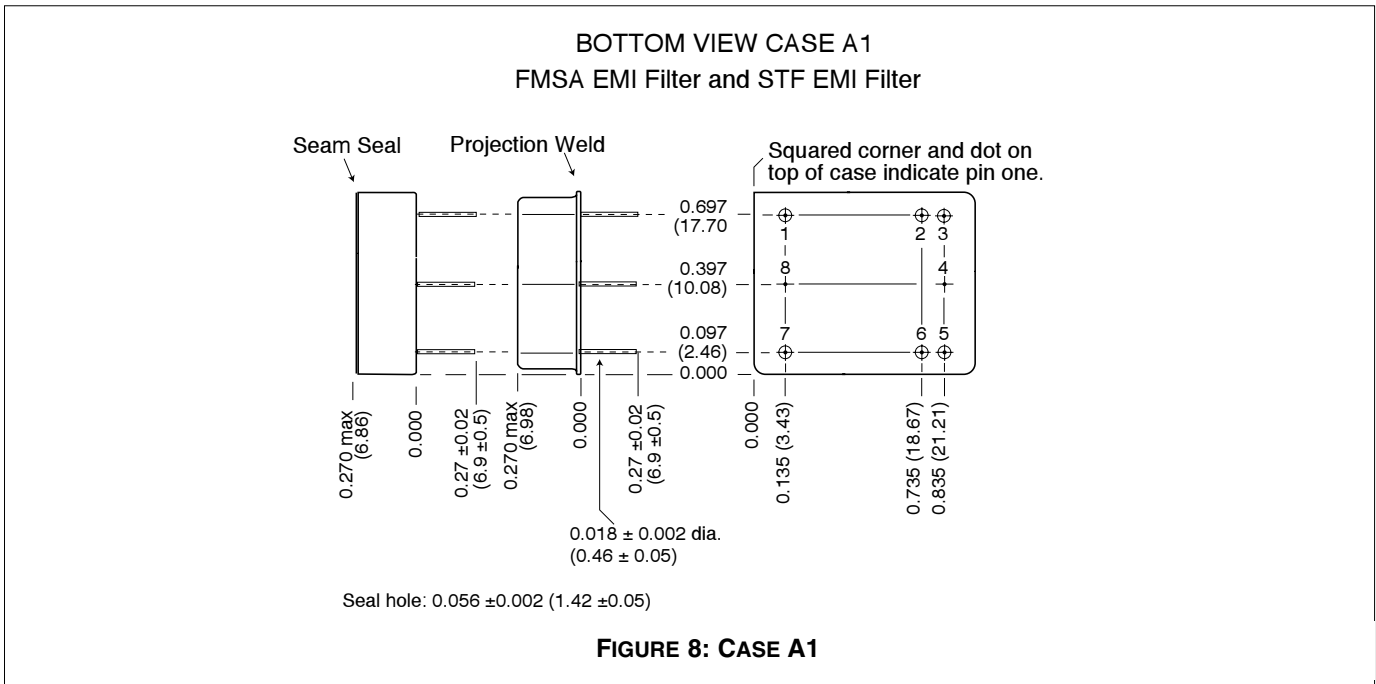
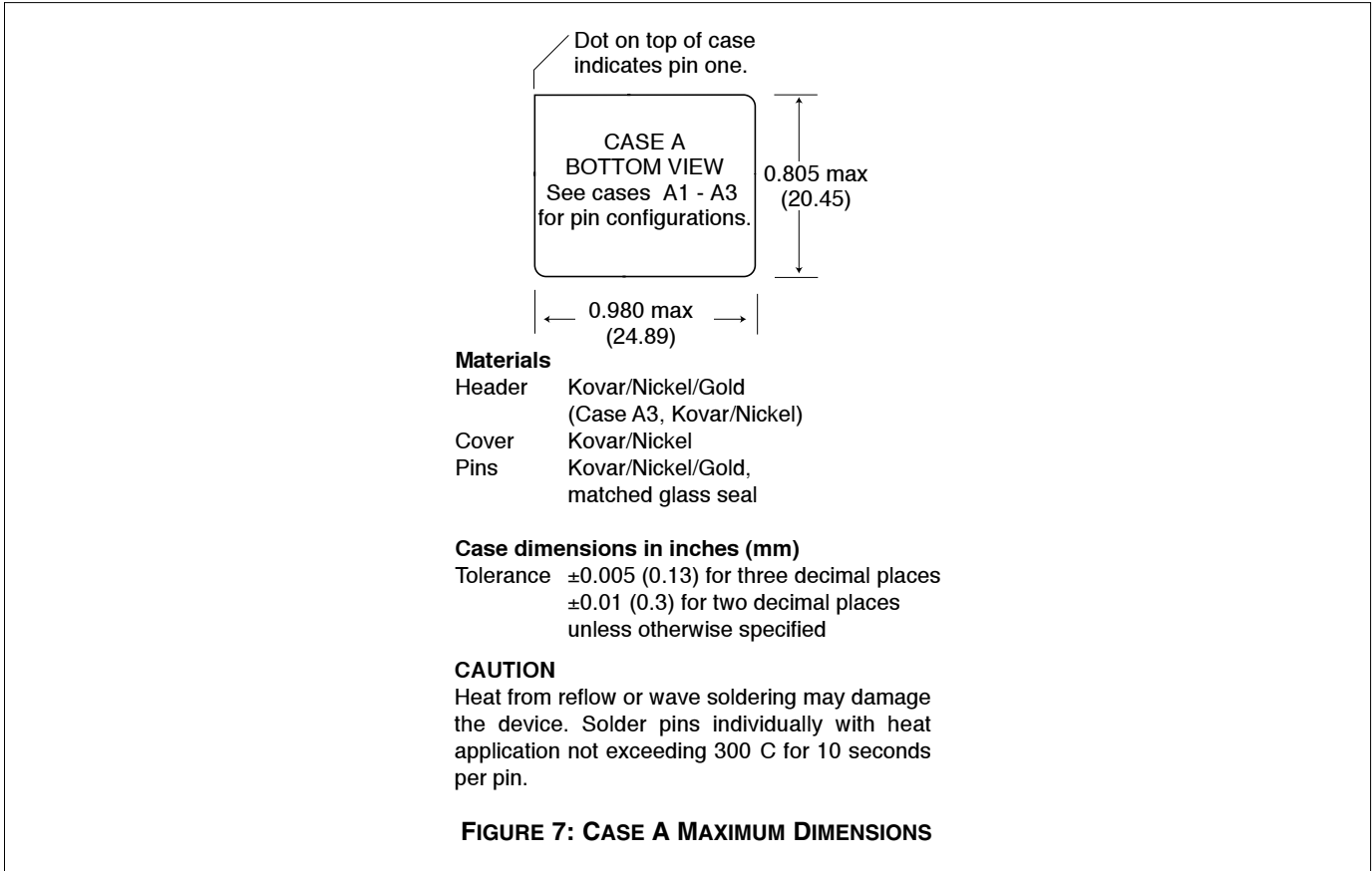

Please refer to the above written numerical dimensions for accuracy.

**125°C PRODUCTS**

<b>TEST (125°C Products)</b>	<b>125°C STANDARD</b>	<b>125°C /ES</b>	<b>/883 (Class H)*</b>
Pre-cap Inspection Method 2017, 2032	yes	yes	yes
Temperature Cycle (10 times) Method 1010, Cond. C, -65°C to 150°C, ambient Method 1010, Cond. B, -55°C to 125°C, ambient	no no	no yes	yes no
Constant Acceleration Method 2001, 300 g Method 2001, 500g	no no	no yes	yes no
Burn-In Method 1015, 160 hours at 125°C case, typical 96 hours at 125°C case, typical	no no	no yes	yes no
Final Electrical Test MIL-PRF-38534, Group A Subgroups 1 through 6: -55°C, +25°C, +125°C case Subgroups 1 and 4: +25°C case	no yes	no yes	yes no
Hermeticity Test Fine Leak, Method 1014, Cond. A Gross Leak, Method 1014, Cond. C Gross Leak, Dip (1 x 10 <sup>-3</sup> )	no no yes	yes yes no	yes yes no
Final Visual Inspection Method 2009	yes	yes	yes

Test methods are referenced to MIL-STD-883 as determined by MIL-PRF-38534.

\*883 products are built with element evaluated components and are 100% tested and guaranteed over the full military temperature range of -55°C to +125°C.