

# Element Key Switches SOP Series

## FEATURES

1. Extra low-profile 0.6mm thickness.
2. Surface mounting type and permits re-flow soldering.  
Taping type for auto mounting is available.
3. Click feel with metal diaphragm contact.



## USES

1. For VCR camcorder, thin and compact sets.
2. For portable audio and visual equipments.
3. Portable telephone, pager and compact telecommunication equipments.

## MODEL NAME CODE

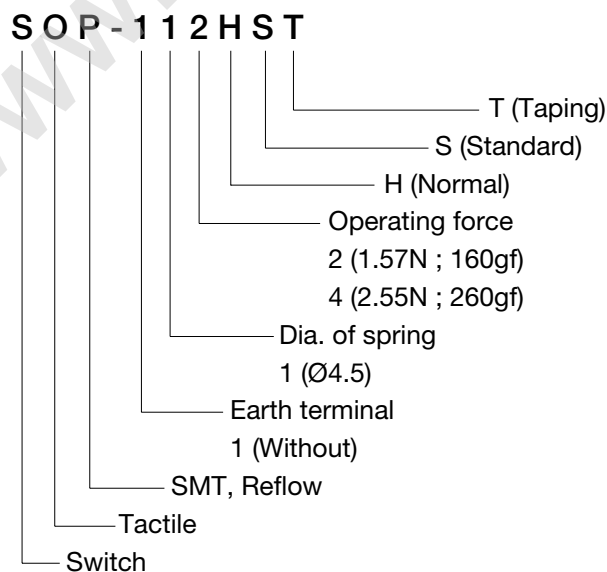

## SPECIFICATIONS

Electrical Characteristics	Rating	50mA, 12V DC
	Contact Resistance	1Ω or less
	Insulation Resistance	100MΩ or more
	Withstand Voltage	1 minute at 100V AC
	Bouncing	10mS or less
Mechanical Characteristics	Operating Force	1.57N, 2.55N (160gf, 260gf)
Life		100,000 cycles

## TYPE

Model Name Code	Order Number	Operating Force
SOP-112HST	R66 5373	1.57N (160gf)
SOP-114HST	R66 5374	2.55N (260gf)

## DIMENSIONS

Outer Dimensions

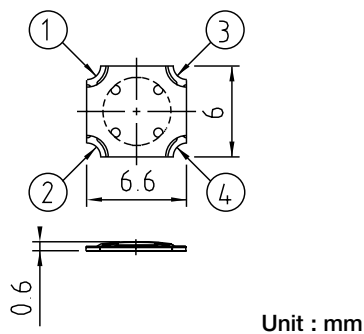

Circuit Diagram

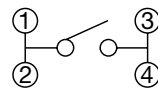

Mounting Pattern

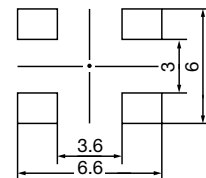

## TAPING SPECIFICATIONS

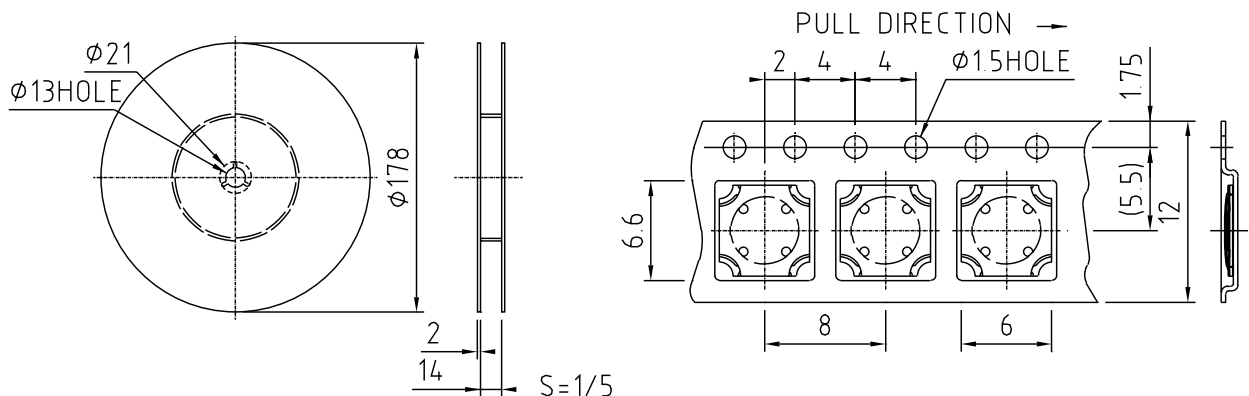

\*One reel accommodates 1,000 pieces (Ø178) or 5,000 pieces (Ø330).

■ NOTICE

- (1) Please do not wash this switch.
- (2) A rule of this switch position don't making with taping.
- (3) Minimum packing Unit : 1,000Pcs./Reel.