



CML

INNOVATIVE TECHNOLOGIES, INC.

WHERE INNOVATION COMES TO LIGHT

Americas

147 Central Avenue
Hackensack, NJ 07601
(201) 489-8989
www.cml-it.com

Europe

Robert Bunsen Str. 1
D-67098 Bad Dürkheim
+49 (6322) 9567-0
www.cml-it.com

CMDA36 Series Power LED (2.5 Watt)

- Features

- Super high flux output and high luminance
- Designed for high current operation
- Low thermal resistance
- SMT solder compatible
- Lead (Pb) Free Product – RoHS Compliant

- Applications

- General Illumination
 - Outdoor & Indoor Architectural Lighting
 - Decorative Lighting
 - Portable Lighting / Flash Light (Torch) Lamps
 - Reading Lamps and Task Lighting
 - Traffic Signaling

- Description

These packaged LED's are designed for high current operation and high flux output applications. The package design features better thermal management characteristics than other LED solutions. Because of these advantages, this product has many applications such as internal & external lighting, automobile lighting, large size LCD backlight, etc.

Americas

147 Central Avenue
 Hackensack, NJ 07601
 (201) 489-8989
www.cml-it.com

Europe

Robert Bunsen Str. 1
 D-67098 Bad Durkheim
 +49 (6322) 9567-0
www.cml-it.com

1. Outline Dimensions

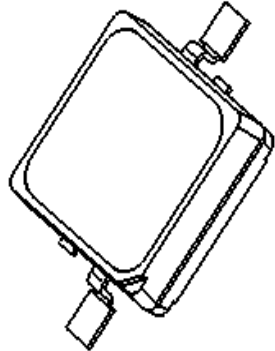

Isometric view
 Scale: None

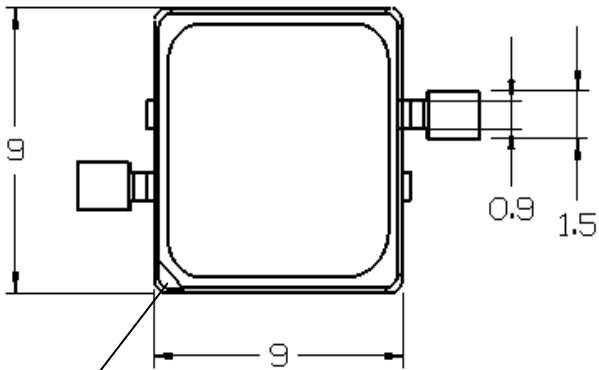

Cathode Mark

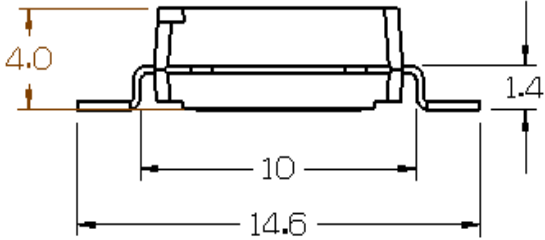

Slug (+)

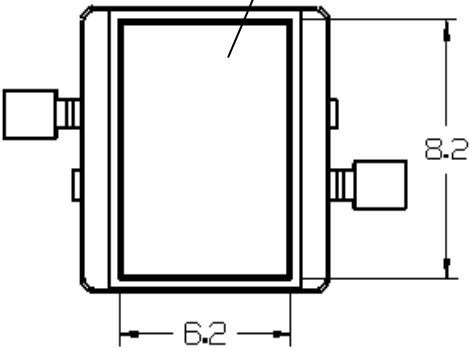

Rear view

- Notes : 1. All dimensions are in millimeters.
- 2. Scale : none
- 3. This drawing is reference only for engineering



Americas

147 Central Avenue
 Hackensack, NJ 07601
 (201) 489-8989
www.cml-it.com

Europe

Robert Bunsen Str. 1
 D-67098 Bad Durkheim
 +49 (6322) 9567-0
www.cml-it.com

2. Electro-Optical Characteristics (at IF=700mA, TA=25°C)

P/N	Description	Luminous Flux Min./Typ. (lm)	Correlated Color Temperature (Kelvin)	CRI	Dominant Wavelength (nm) Min./Typ./Max.	Forward Voltage (volts) Min./Typ./Max.	View Angle (degrees)	Thermal resistance (°C /W)
	Symbol	ΦV [1]	CCT [3]	Ra	λD	V	2θ 1/2	Rθ [4]
CMDA36CW15D13L	Pure White	70 / 103	6500	76		3.0 / 3.4 / 4.3	110	9.1
CMDA36WW15D13L	Warm White	54 / 60	3000	76		3.0 / 3.4 / 4.3	110	9.1
CMDA36CB15D13L	Blue	14 / 18			455 / 460 / 475	3.0 / 3.4 / 4.3	130	9.1
CMDA36AG15D13L	Green	54 / 93			520 / 527 / 535	3.0 / 3.4 / 4.3	130	9.1
CMDA36AR15D13L	Red	54 / 60			620 / 625 / 630	2.0 / 2.5 / 3.0	128	13
CMDA36GB15D13L	Cyan	54 / 78			500 / 505 / 510	3.0 / 3.4 / 4.3	130	9.1
CMDA36DY15D13L	Amber	54 / 75			585 / 590 / 595	2.0 / 2.5 / 3.0	128	13

3. Absolute Maximum Ratings (at TA=25°C)

P/N	Description	Forward Current (A)	Power Dissipation (Watts)	Junction Temperature (°C)	Operating Temperature (°C)	Storage Temperature (°C)
	Symbol	I _F	P _D	T _J	T _{opr}	T _{stg}
CMDA36CW15D13L	Pure White	0.8	3.2	125	-30~+85	-40~+120
CMDA36WW15D13L	Warm White	0.8	3.2	125	-30~+85	-40~+120
CMDA36CB15D13L	Blue	0.8	3.2	125	-30~+85	-40~+120
CMDA36AG15D13L	Green	0.8	3.2	125	-30~+85	-40~+120
CMDA36AR15D13L	Red	0.8	2.4	100	-30~+85	-40~+120
CMDA36GB15D13L	Cyan	0.8	3.9	125	-30~+85	-40~+120
CMDA36DY15D13L	Amber	0.8	2.4	100	-30~+85	-40~+120

***Notes:**

- [1] ΦV is the total luminous flux output as measured with an integrating sphere.
- [2] Zener diode chip included to protect the LED from ESD.
- [3] Rθ is measured with a metal core PCB (25 °C ≤ T_J ≤ 125 °C).
- [4] CML maintains a tolerance of ± 10% on flux and power measurements.
- [5] CCT ± 5% tester tolerance.
- [6] Color Coordinate Measurement allowance is ± 0.005
- [7] A tolerance of ± 0.006V on forward voltage measurements

-----**Caution**-----
 Please do not drive at rated current more than 5 sec. without proper heat sink

4. Forward Voltage vs. Forward Current (Ta=25°C)

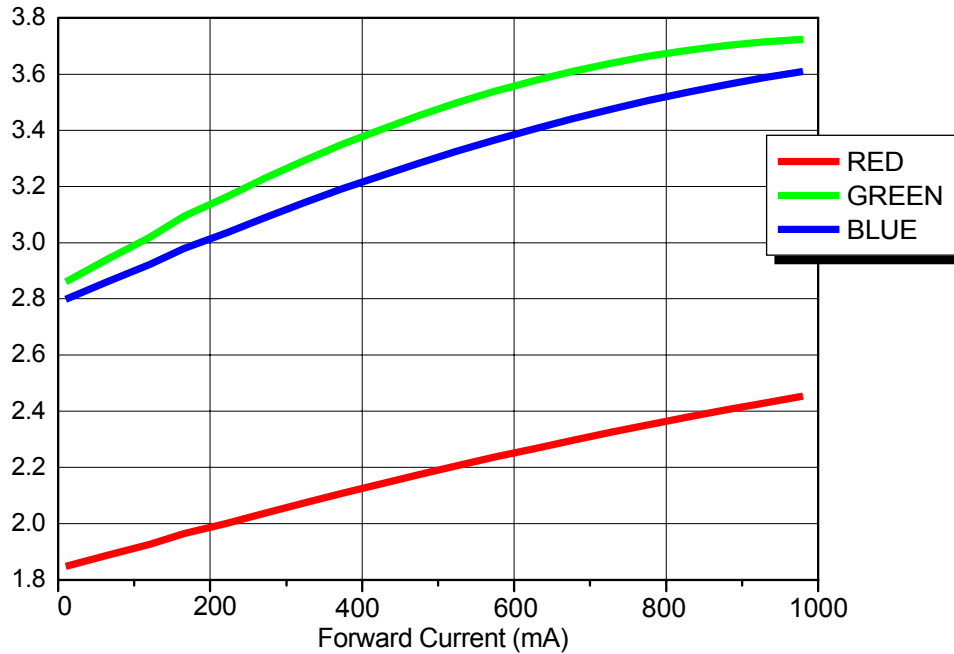

5. Forward Current vs. Normalized Relative Luminous Flux (Ta=25°C)

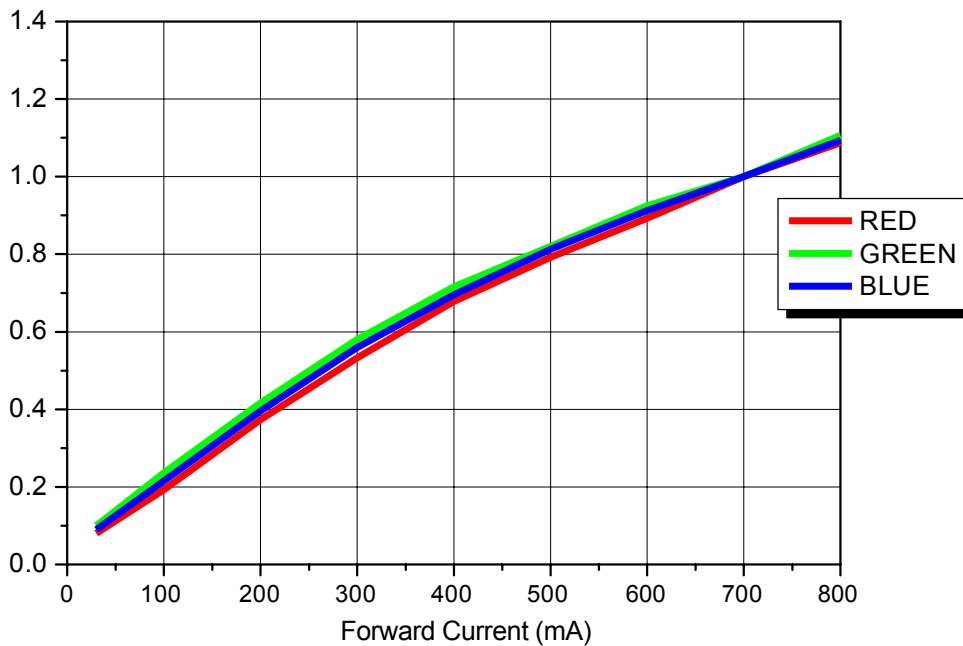

6. White Color spectrum of Typical CCT (Ta=25 °C)

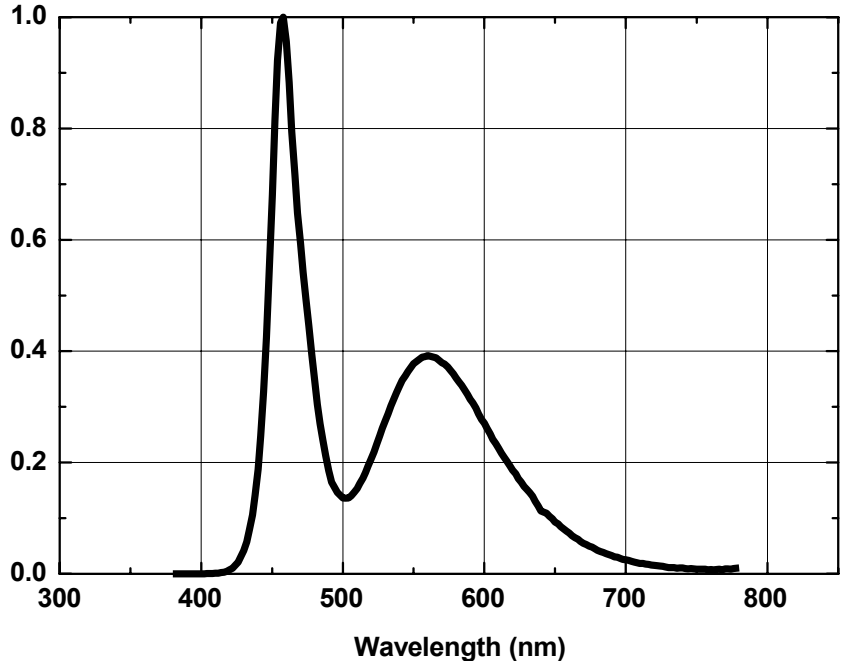

7. Wavelength Curve for Red, Green, Blue (Ta=25 °C)

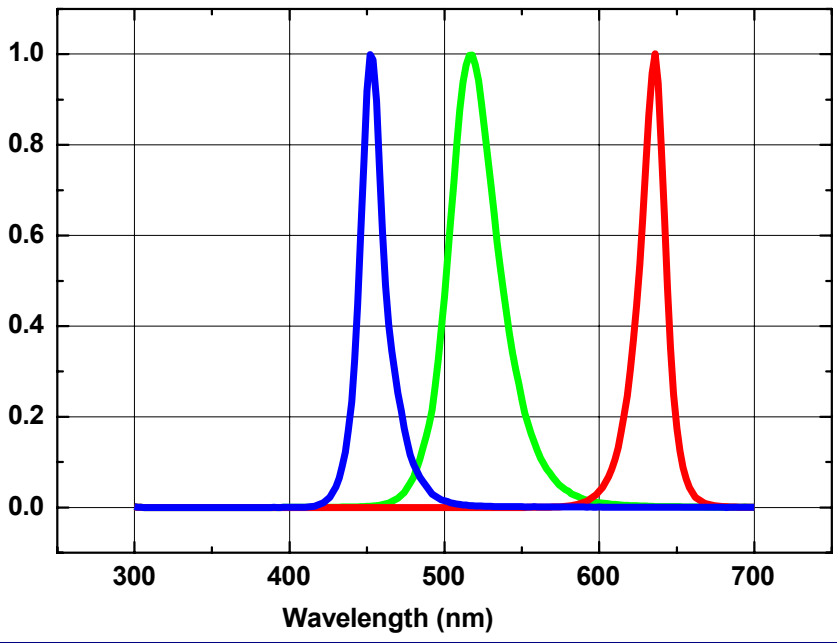

Americas
147 Central Avenue
Hackensack, NJ 07601
(201) 489-8989
www.cml-it.com

Europe
Robert Bunsen Str. 1
D-67098 Bad Durkheim
+49 (6322) 9567-0
www.cml-it.com

14. Forward Current vs. Wavelength shift (Ta=25°C)

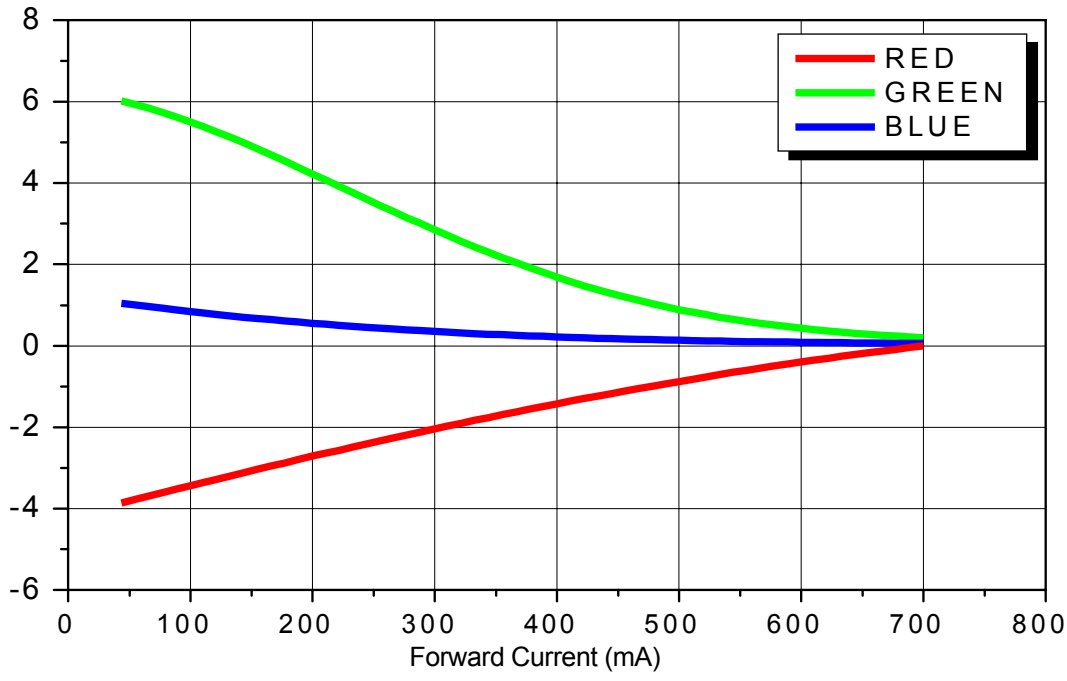

15. Temperature of Junction vs. Relative Light Output for Blue, Green, Red (Ta=25°C)

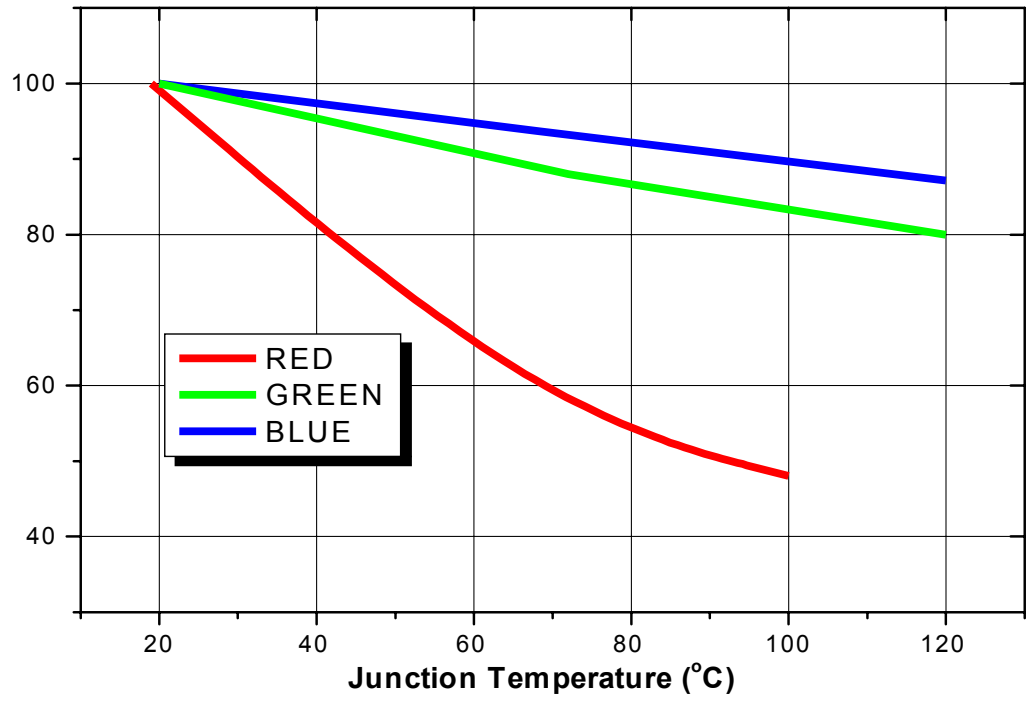

Americas
 147 Central Avenue
 Hackensack, NJ 07601
 (201) 489-8989
www.cml-it.com

Europe
 Robert Bunsen Str. 1
 D-67098 Bad Durkheim
 +49 (6322) 9567-0
www.cml-it.com

16. Ambient Temperature vs. Allowable Forward Current for 2 chip White, Blue, Green, Cyan

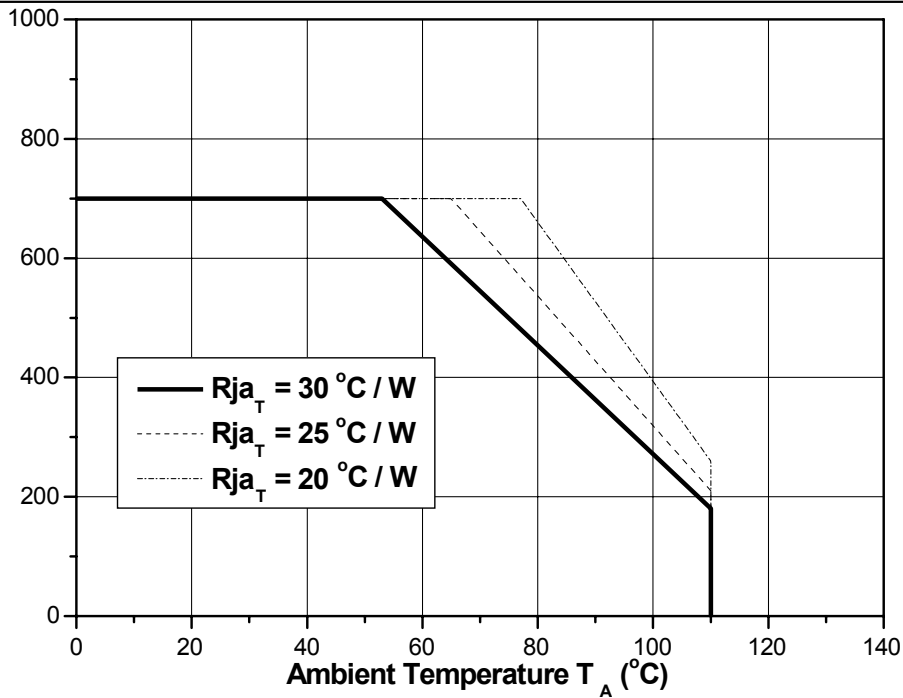

17. Ambient Temperature vs. Allowable Forward Current for 2 chip Red,

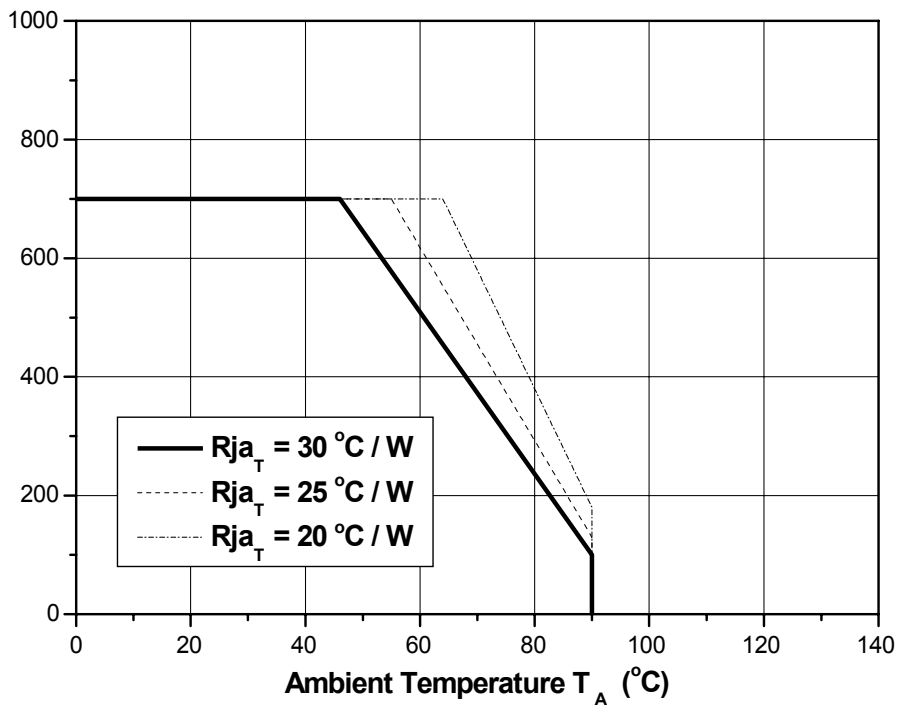

Americas
 147 Central Avenue
 Hackensack, NJ 07601
 (201) 489-8989
www.cml-it.com

Europe
 Robert Bunsen Str. 1
 D-67098 Bad Durkheim
 +49 (6322) 9567-0
www.cml-it.com

18. Reel Packaging

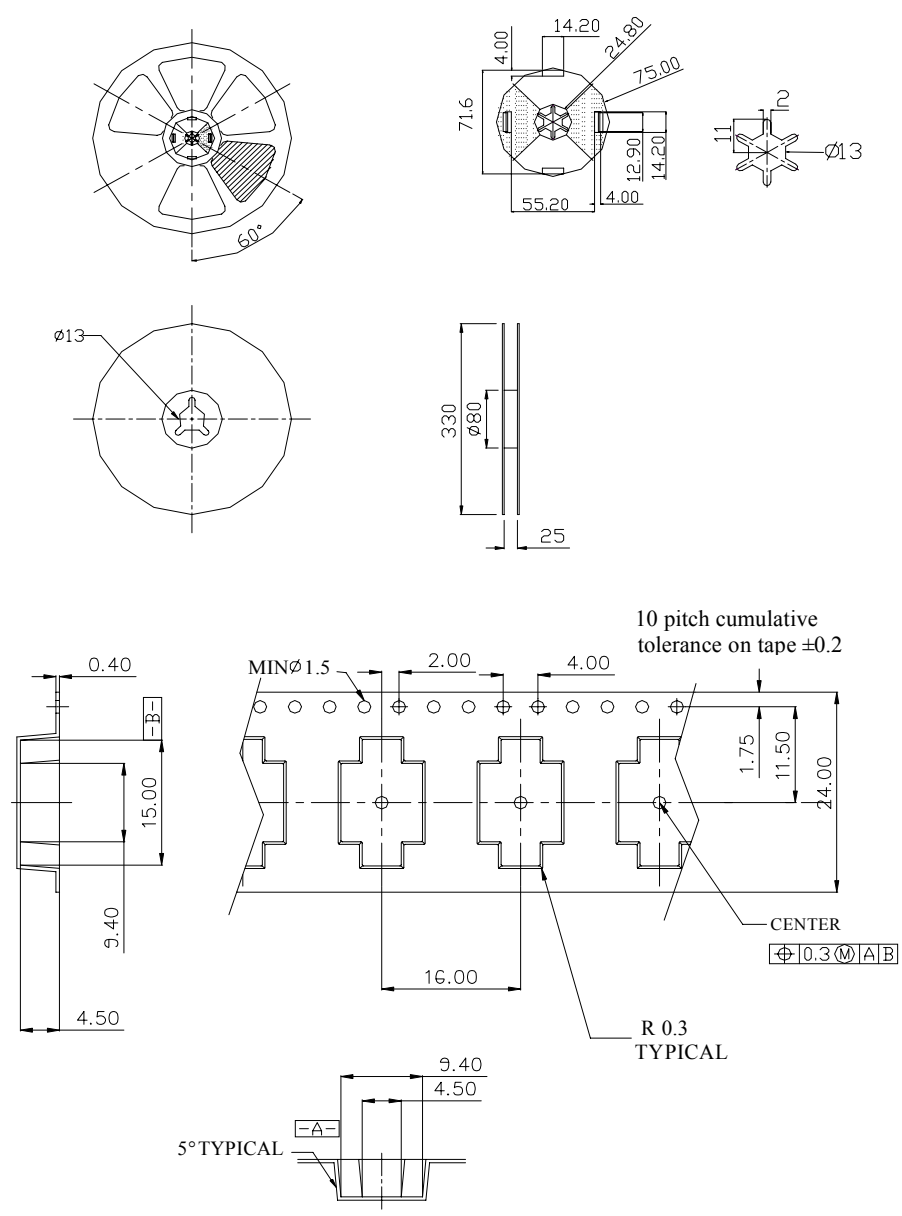

- Note : 1. The number of loaded products in the reel is 750ea
 2. All dimensions are in millimeters
 3. Scale none
 4. This drawing is reference only engineering



Americas
 147 Central Avenue
 Hackensack, NJ 07601
 (201) 489-8989
www.cml-it.com

Europe
 Robert Bunsen Str. 1
 D-67098 Bad Durkheim
 +49 (6322) 9567-0
www.cml-it.com

20. Recommended solder pad

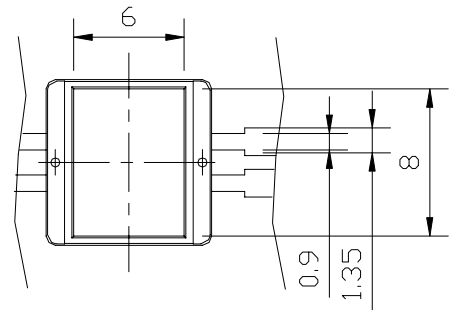
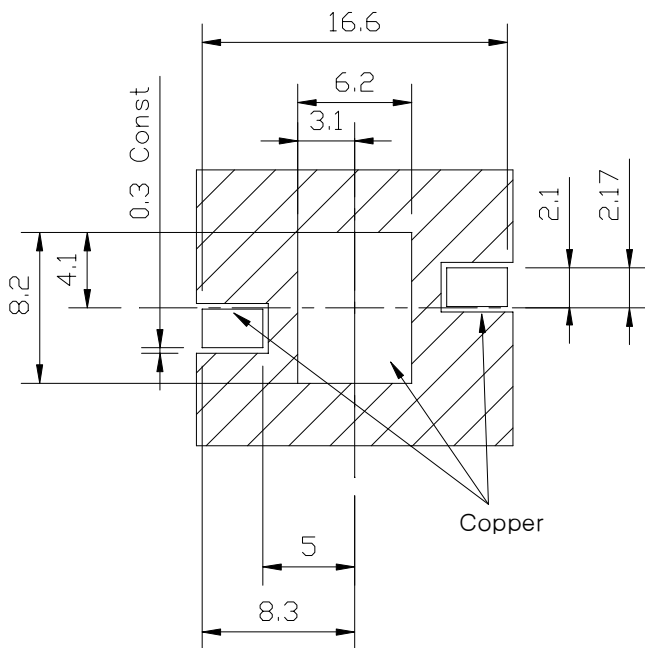
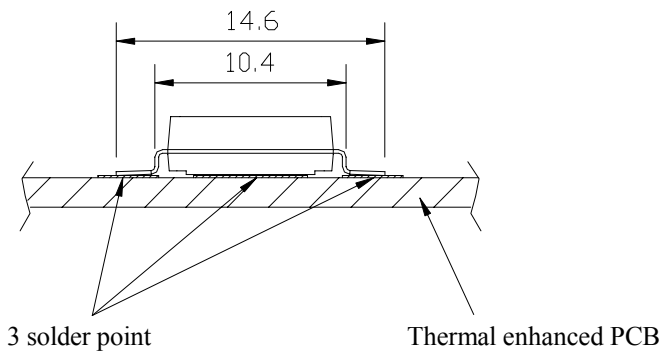

<Rear view>

21. Soldering Profile

- (1) Reflow Soldering Conditions / Profile
Preliminary heating to be at 180°Cmax. for 2 minutes max.
Soldering heat to be at 260°Cmax. for 5 seconds max.

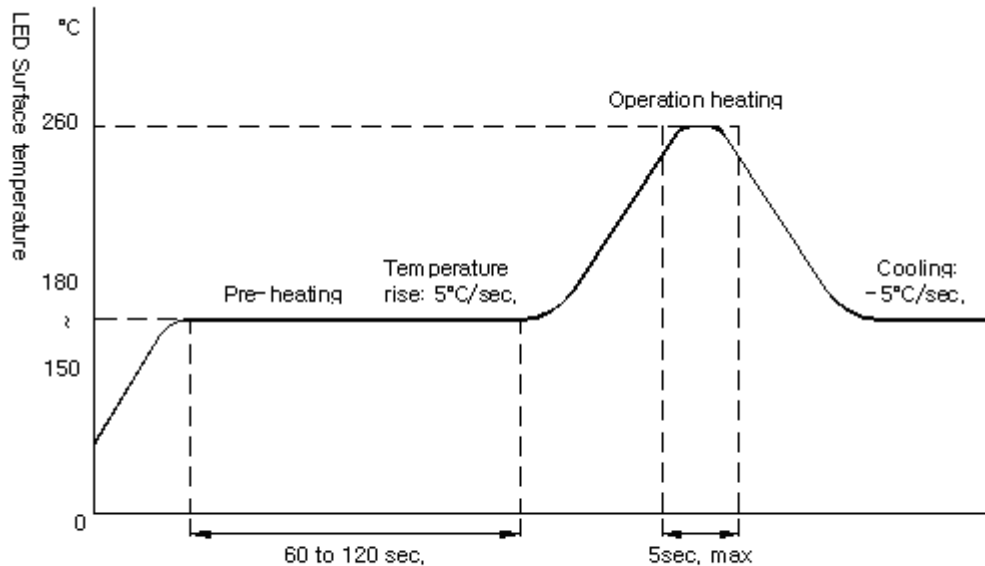

- (2) Hand Soldering conditions
-Lead : Not more than 3 seconds @MAX280°C, under Soldering iron.

Should soldered products be reused during the soldering process, CML-IT voids all liability on the SMT LED units.