

HA13492

Quad Solenoid Driver

Description

The HA13492, a monolithic power IC, is a driver for inductive loads especially for automotive application. Packaged in Single-in-Line 15 pin, contains four driving circuits of 0.8 A. Each driver has OCL* and independent OTSD** circuit to protect the IC from the short circuit of loads. Also include input open circuit protector and all of the failure condition can be reported by diagnostic circuit.

* OCL : Over current limiter

** OTSD : Over temperature shut down

Functions

- 0.8 A quad driver
- With clamp diodes
- With chip Enable
- With over voltage protector circuit
- With short circuit protector (OCL & OTSD)
- With diagnostic circuit
- With fail safe function under input open circuit condition

Features

- High sustaining voltage (45 V)
- Low saturation voltage
- Wide operating supply voltage range ($V_{CC} = 7$ to 25 V)
- Can stand for reverse voltage
- Low standby current (200 μ A max)
- With independent short circuit protector for each channel
- Compatible with TTL, LS-TTL and 5 V CMOS

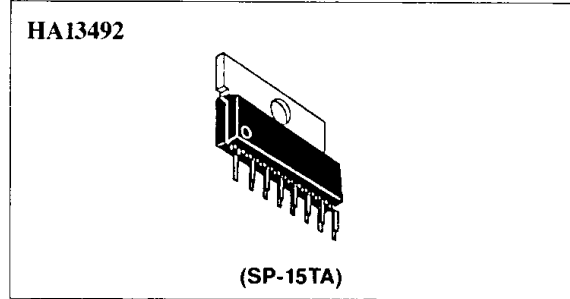

Pin Arrangement

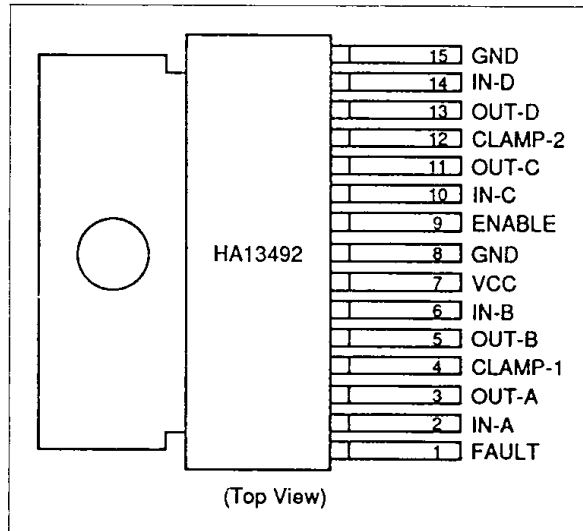

Ordering Information

Type No.	Package
HA13492	SP-15TA



HA13492

Truth Table

Enable	In	Out	Fault	Operating condition
L	X	H	H	Normal condition
H	H	L	H	
H	L	H	H	
H	H	H	L	Short circuit of load, OCL, OTSD, OVSD
H	L	L	L	Open circuit of load

Enable, in {
 H : High level ; 2.0 V
 L : Low level ; 0.8 V
 X : Don't care

Block Diagram

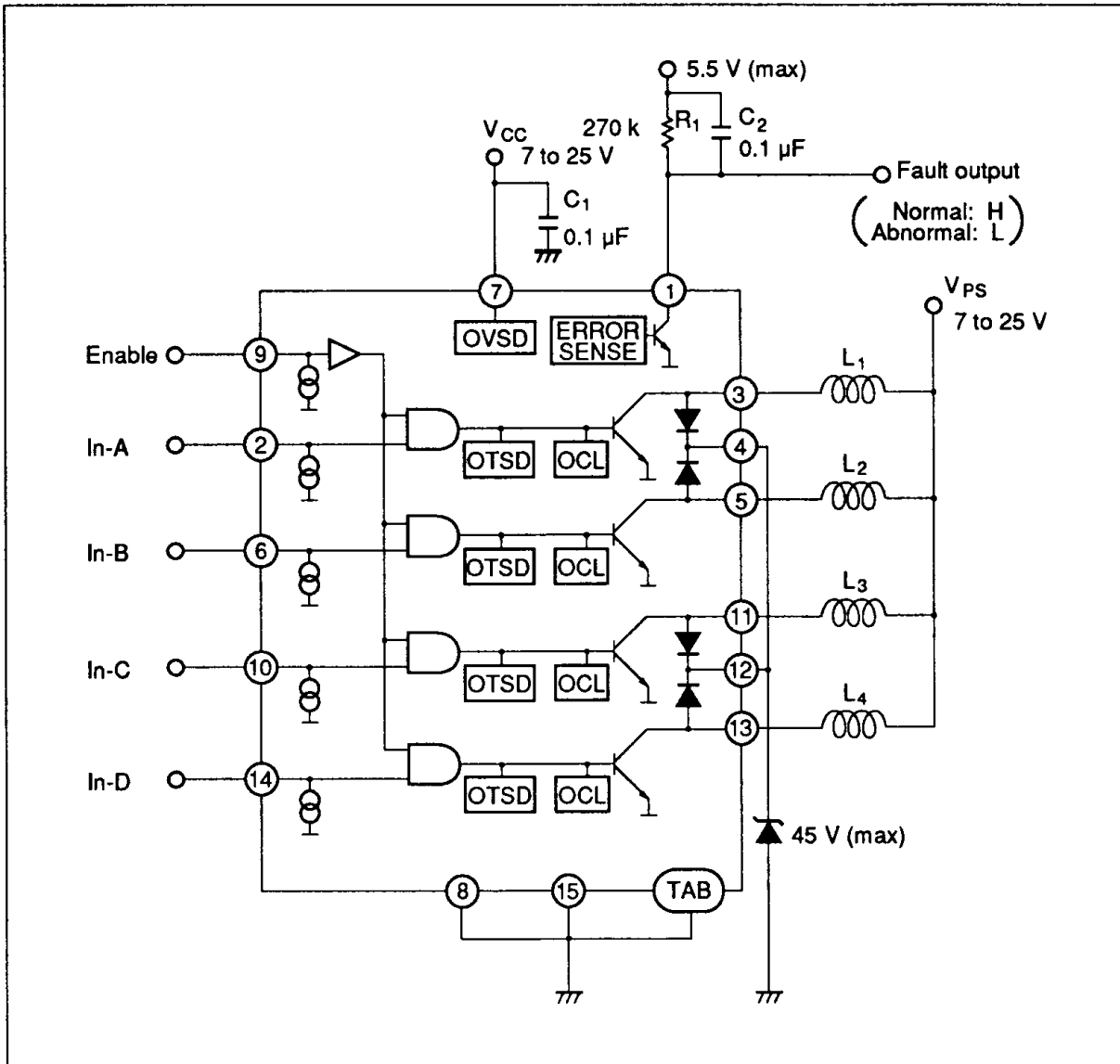

Absolute Maximum Ratings (Ta = 25°C)

Item	Symbol	Ratings	Units	Note
Supply voltage	V _{CC}	-13 to 45	V	1
Input voltage	V _{IN}	-0.6 to 7	V	
Output voltage	V _{CEX}	45	V	
Output current	I _O	1.5	A	2
Power dissipation	P _T	3.5	W	
Junction temperature	T _j	150	°C	
Operating junction temperature range	T _{jop}	-40 to +135	°C	
Storage temperature range	T _{stg}	-55 to +150	°C	
Package thermal resistance	θ _{j-c}	3	°C/W	3
	θ _{j-a}	60	°C/W	

The absolute maximum ratings are limiting values, to be applied individually, beyond which the device may be permanently damaged. Functional operation under any of these conditions is not guaranteed. Exposing a circuit to its absolute maximum rating for extended periods of time may affect the device's reliability.

- Notes:
1. Recommended operating voltage
V_{CC} = 7 to 16 V (normal)
16 to 25 V (jump start)
 2. Internally limited.
 3. θ_{j-c}; Thermal resistance from junction to case
θ_{j-a}; Thermal resistance from junction to air



HA13492

Electrical Characteristics (Ta = 25°C, Vcc = 12 V ±10%)

Item	Symbol	Min	Typ	Max	Units	Test condition	Applicable pin	Note	
Supply current	I_{CCO}	—	55	200	μA	Enable = 0.8 V	7		
	I_{CC}	—	80	100	mA	Enable = 2 V, $I_{out} = 0 \text{ to } 0.8 \text{ A} \times 4 \text{ CH}$			
Input	Low level voltage	V_{IL}	—	—	0.8	V		9, 2, 6 10, 14	
	High level voltage	V_{IH}	2.0	—	—	V			
	Low level current	I_{IL}	—10	—	40	μA	$V_{IN} = 0 \text{ to } 0.8 \text{ V}$ (Enable = 2 V)	2, 6 10, 14	
			—10	—	40	μA	Enable = 0 to 0.8 V	9	
	High level current	I_{IH}	10	35	60	μA	$V_{IN} = 2.0 \text{ to } 5.5 \text{ V}$ (Enable = 2 V)	2, 6 10, 14	
			10	40	60	μA	Enable = 2.0 to 5.5 V	9	
			—5	—	10	μA	$V_{IN} = 5.5 \text{ V}$ (Enable = 0.8 V)	2, 6 10, 14	
	Output	Low level voltage	$V_{CE(sat)}$	—	0.08	0.15	V	$I_{out} = 0.1 \text{ A}$	3, 5, 11 13
				—	0.30	0.40	V	$I_{out} = 0.5 \text{ A}$	
				—	0.60	0.75	V	$I_{out} = 0.8 \text{ A}$	
Leakage current		I_{CEX1}	—	0.5	5	mA	Enable = 2 V, $V_{IN} = 0.8 \text{ V}$ $V_{CE} = 45 \text{ V}$		
			200	400	600	μA	Enable = 2 V, $V_{IN} = 0.8 \text{ V}$ $V_{CE} = 12 \text{ V}$		
			—	—	100	μA	Enable = 0.8 V, $V_{CE} = 45 \text{ V}$		
Sustaining voltage		$V_{CE(sus)}$	45	—	—	V		1	
Clamp diode	Forward voltage	V_F	—	1.3	2.0	V	$I_F = 1.0 \text{ A}$	3, 4, 5, 11 12, 13	
			—	1.5	2.5	V	$I_F = 1.5 \text{ A}$		
	Leakage current	I_R	—	—	100	μA	$V_R = 50 \text{ V}$		
Fault out	Sink current	I_{OL}	30	—	125	μA	$V_{Fault} = 1 \text{ to } 5.5 \text{ V}$	1	
	Low level voltage	V_{OL}	—	0.2	0.4	V	$I_{Fault} = 30 \mu\text{A}$		
	Leakage current	I_{LEAK}	—	—	2	μA	$V_{Fault} = 1 \text{ to } 5.5 \text{ V}$		



Electrical Characteristics (Ta = 25°C, VCC = 12 V ±10%) (cont)

Item	Symbol	Min	Typ	Max	Units	Test condition	Applicable pin	Note
Output error sense threshold voltage	V ⁺	—	—	7	V	Enable = 2 V, V _{IN} = 2 V	3, 5, 11 13	3
	V ⁻	3	—	—	V	Enable = 2 V, V _{IN} = 0.8 V		
Turn on and turn off delay	t _{PHL}	—	8	15	μs	I _{out} = 0.5 A	2, 6, 10 14, 3, 5 11, 13	
	t _{PLH}	—	3	15	μs			
OVSD Starting voltage	V _{OVSD}	25.5	—	31	V		7	
	Hysteresis V _{HYS}	0.25	—	—	V			
OCL starting current	I _{OCL}	—	1.2	1.5	A		3, 5, 11 13	4
OTSD Starting temp	OTSD	145	—	—	°C			5
	Hysteresis T _{HYS}	—	—	20	°C			

- Notes: 1. See figure 1
 2. See figure 2
 3. See figure 3
 4. See figure 4
 5. Design parameter only

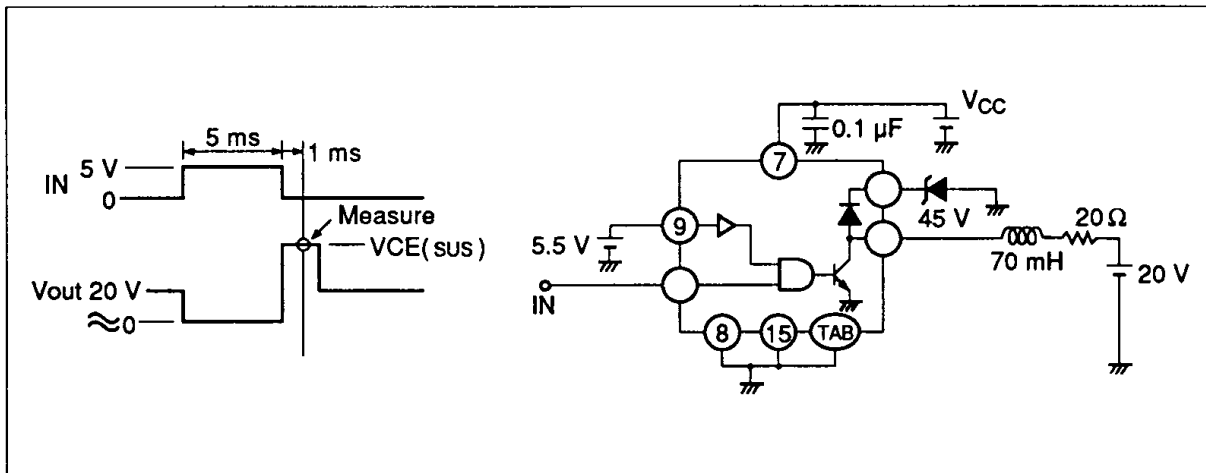

Figure 1 Output Sustaining Voltage Test

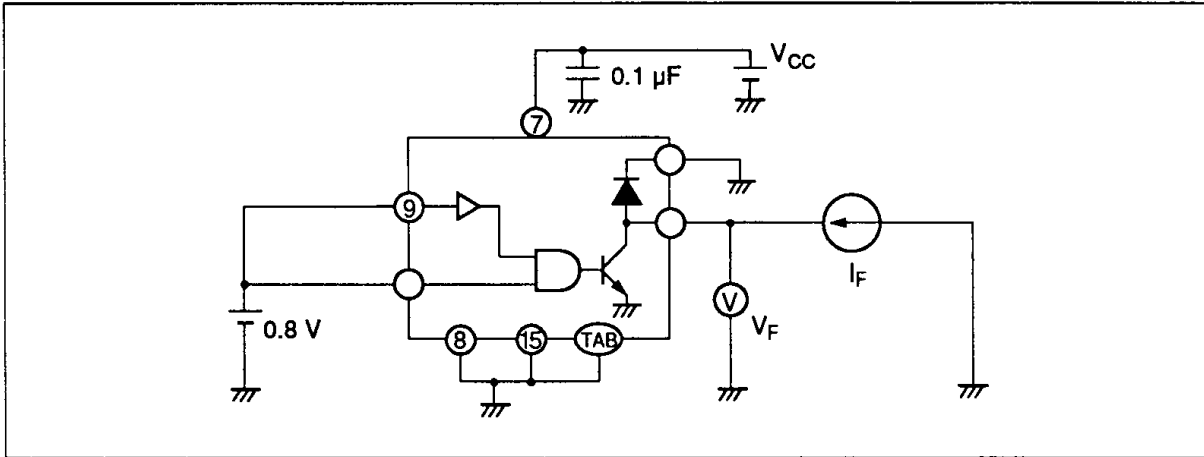

Figure 2 Clamp Diode V_F Test

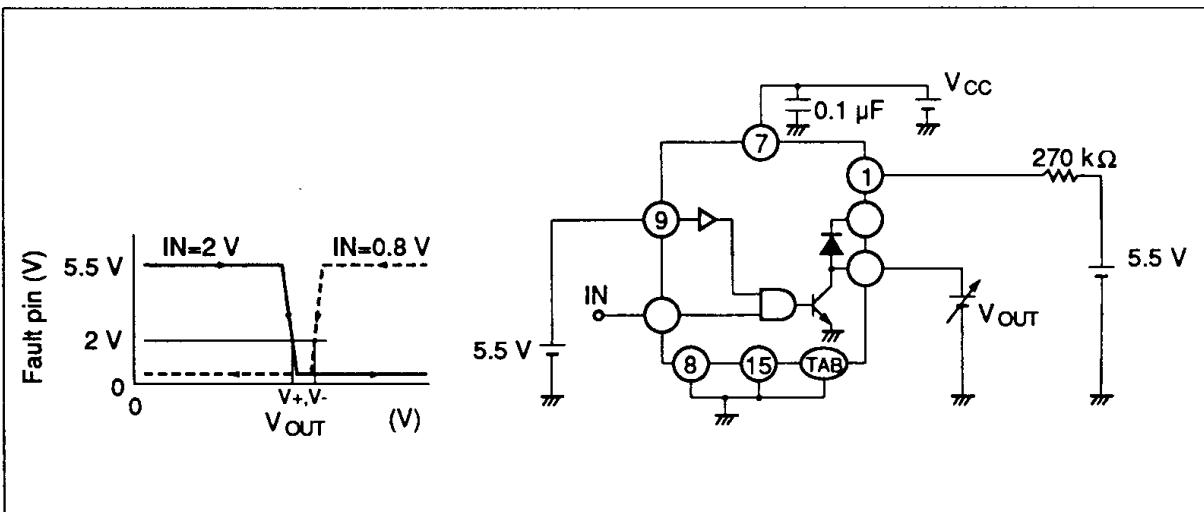

Figure 3 Output Error Sense Threshold Voltage Test

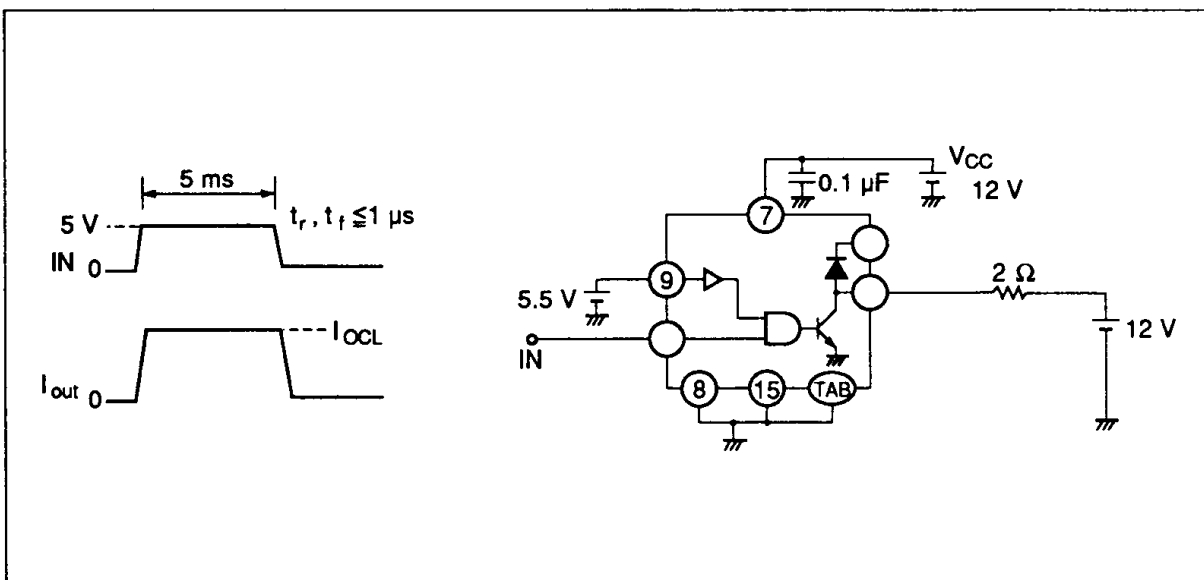

Figure 4 Over Current Limiter Test

