

---

# HA1220F

## CD-ROM Drive Head Amplifier IC

# HITACHI

ADE-207-230 (Z)

Target Specification  
1st. Edition  
April 1997

---

### Functions

- RF amplifier (Built-in equalizer changing circuit)
- Focus error amplifier ( $f_c = 60\text{kHz Typ}$ )
- Tracking error amplifier (Built-in cut-off frequency changing circuit  $f_c = 30\text{kHz}, 60\text{kHz}, 100\text{kHz}, 200\text{kHz Typ}$ )
- FOK detection circuit (Built-in  $V_{th}$  changing circuit)
- Mirror detection circuit
- Defect detection circuit
- APC amplifier
- RFAGC amplifier

### Features

- Built-in variable resistors (+14 to -16% 2% steps) for adjusting tracking error EF balance
- Built-in variable resistors (-8 to +8dB 4dB steps) for rough adjusting tracking gain
- Built-in variable resistors (-8 to +8dB 4dB steps) for rough adjusting focus gain
- Built-in focus offset insertion circuit (-0.7 to +0.7V in 0.1V steps)
- RF amplifier frequency characteristics 30MHz (-3dB) in case of peaking off
- High-speed access support (The mirror circuit internal time constant can be switched between normal, 4× and 8× modes.)
- Support for CD-RW playback
- Few external components
- Available to set the stand-by mode
- FP-28TB package

# HA12220F

## Block Diagram

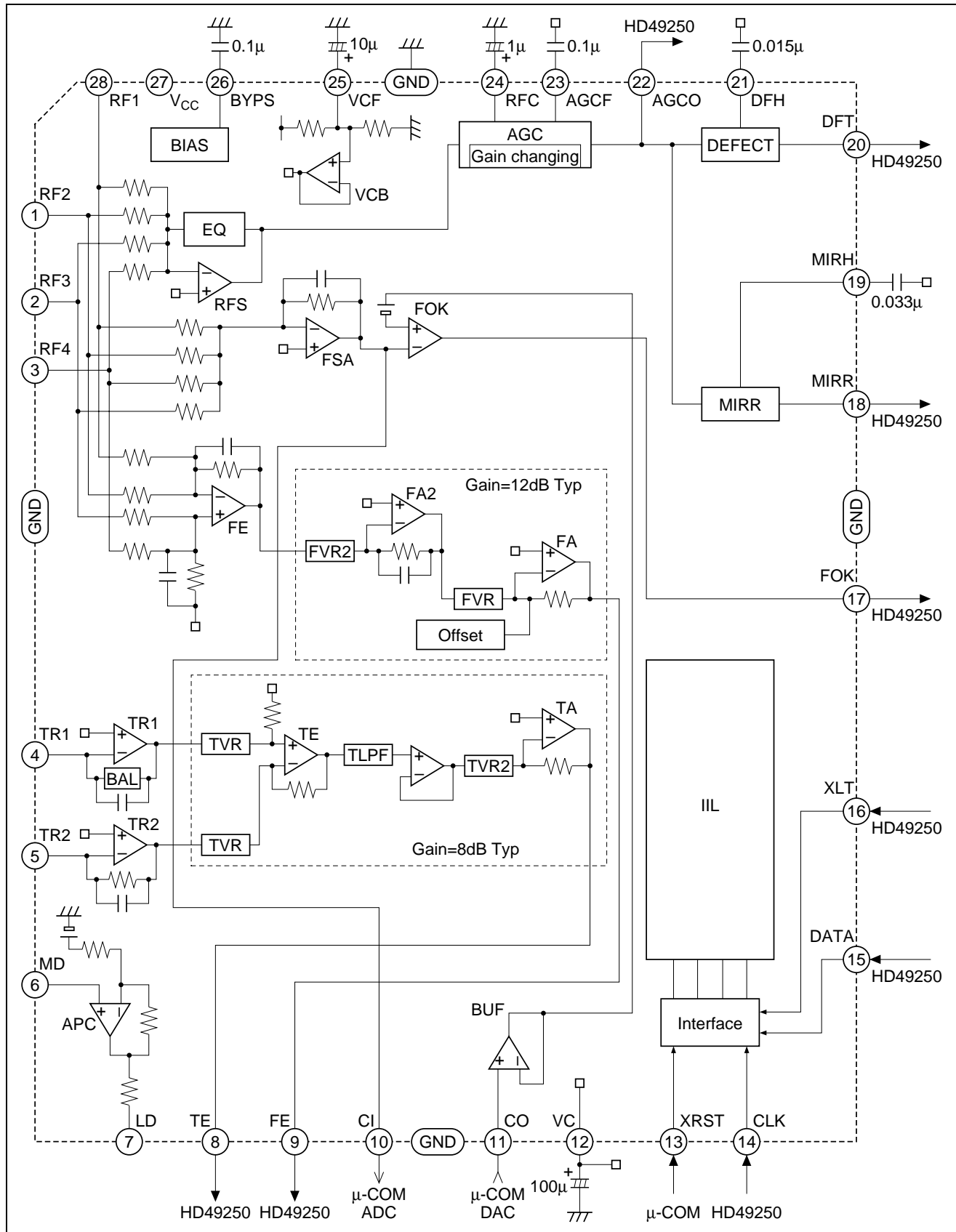

Pin Description and Equivalent Circuit

Pin No.	Pin Name	Equivalent Circuit	Function
1	RF2		RF FE FSA amplifier input2
2	RF3		RF FE FSA amplifier input3
3	RF4		RF FE FSA amplifier input4
28	RF1		RF FE FSA amplifier input1
4	TR1		TR1 amplifier input
5	TR2		TR2 amplifier input
6	MD		APC amplifier input
7	LD		APC amplifier output
8	TE		Tracking error signal output
9	FE		Focus error signal output

# HA12220F

## Pin Description and Equivalent Circuit (cont)

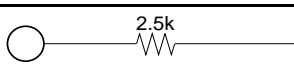
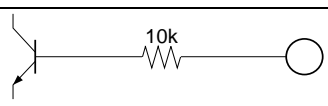
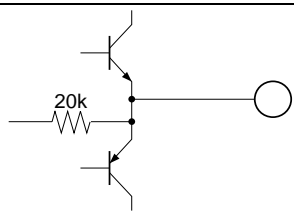
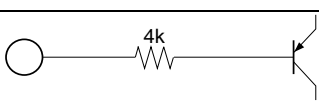
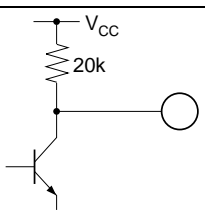
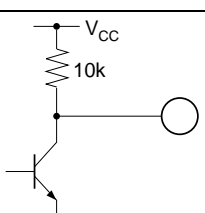
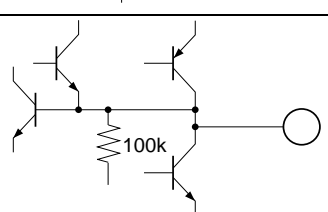
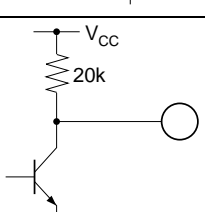
Pin No.	Pin Name	Equivalent Circuit	Function
10	CI		FSA amplifier output monitor
11	CO		Setting FOK reference voltage
12	VC		Reference voltage output
13	XRST		Reset input
14	CLK		Serial data synchronous clock input
15	DATA		Serial data input
16	XLT		Serial data latch input
17	FOK		FOK detection signal output
18	MIRR		Mirror detection signal output
19	MIRH		Mirror envelope hold signal output
20	DFT		Defect detection signal output

**Pin Description and Equivalent Circuit (cont)**

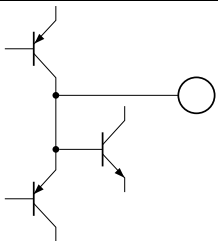
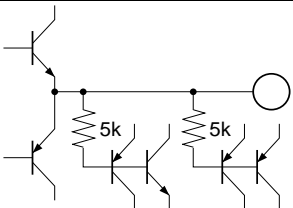
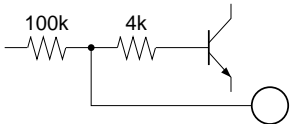
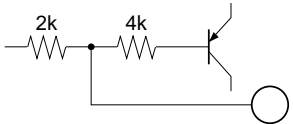
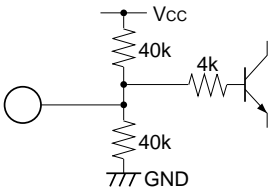
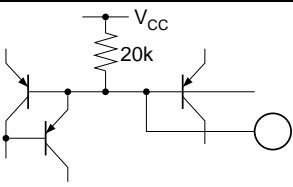
Pin No.	Pin Name	Equivalent Circuit	Function
21	DFH		Defect envelope hold signal output
22	AGCO		AGC amplifier output
23	AGCF		Capacitor connection for AGC
24	RFC		Capacitor connection for AGC
25	VCF		Capacitor connection for reference voltage ripple filter
26	BYPS		Capacitor connection for ripple filter
27	V <sub>cc</sub>	—	V <sub>cc</sub>

## Operation

### Control by Serial Data

The IC's internal switches can be operated by sending control data from the HD49250. The signal timing is shown in figure 1, and the control commands are listed in table 1 and 2.

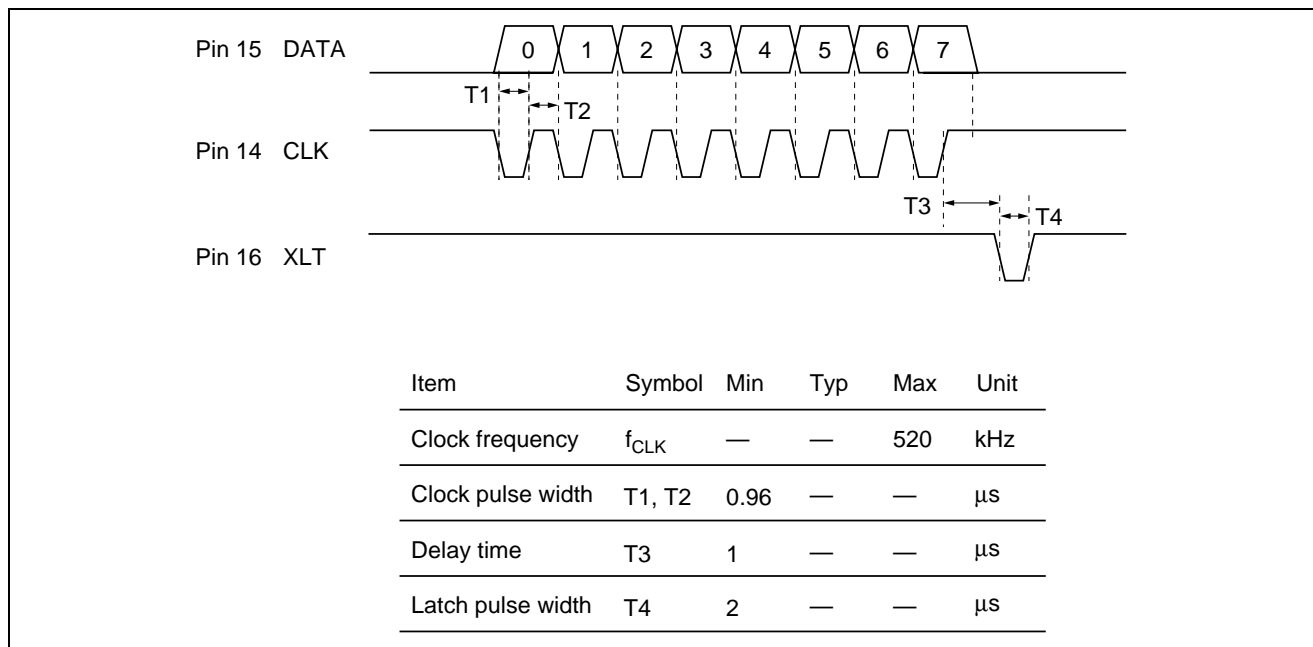

**Figure 1 Timing Diagram for Serial Data Control**

Signals from the HD49250 are input at pins 14 to 16. Pin13 is connected to the microcomputer. A low input at the XRST pin resets the IC. Normally this pin should be kept high.

The serial data from the HD49250 switches the following settings.

1. Tracking error EF balance
2. Focus offset
3. Tracking gain, Focus gain
4. FOK Vth
5. Mirror circuit, defect circuit normal speed / 4× speed / 8× speed mode
6. Tracking error cut-off frequency
7. APC amplifier ON/OFF
8. RF equalizer
9. Stand-by mode (cleared by setting XRST on)

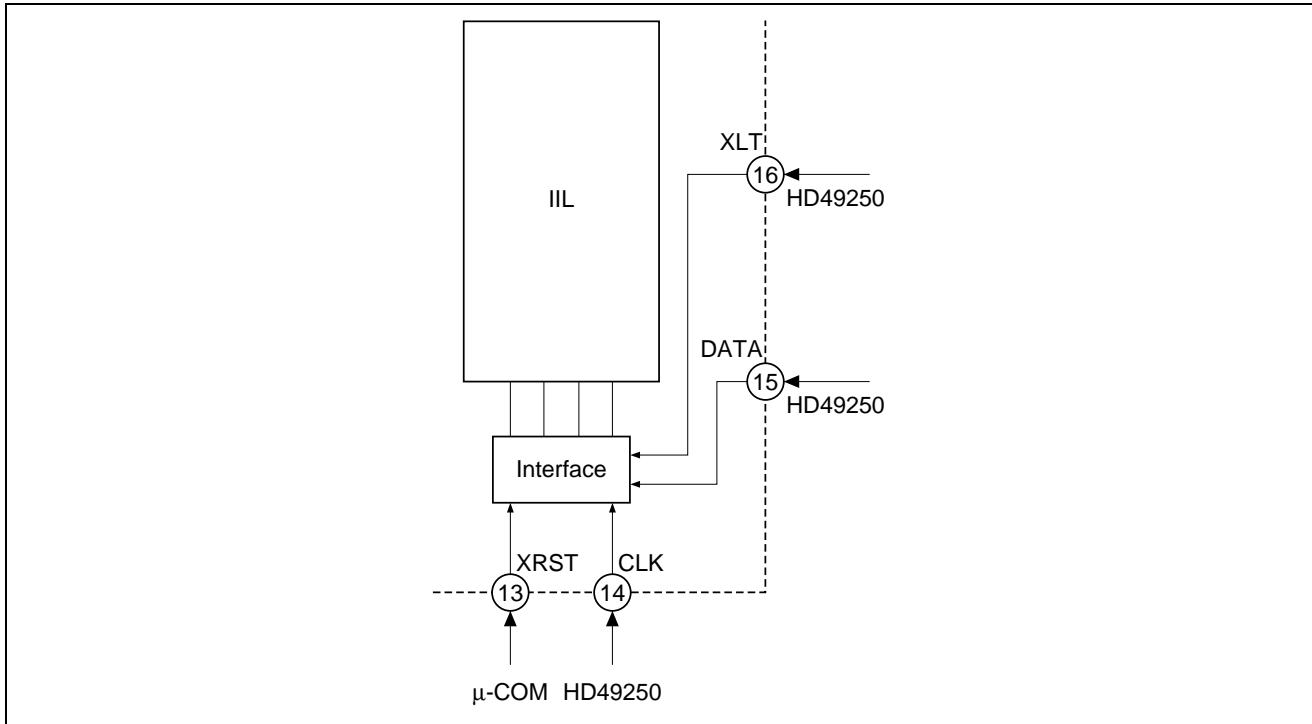

Figure 2 Serial Data Control

**Table 1 Serial Data Control Command 1**

	DATA							Note			
	D7	D6	D5	D4	D3	D2	D1		D0		
Focus error gain CD-RW	0	0	0	CD-RW *1	Focus error gain				0		
					D3	D2	D1	Gain (dB)			
					0	0	0	0			
					0	1	1	-4			
					0	1	0	-8			
					1	0	1	+7.9			
					1	1	0	+4.3			
Focus error offset	0	0	1	D4	D3	D2	D1	Offset (V)	0		
				1	1	1	1	+0.7			
					1	1	0	+0.6			
					1	0	1	+0.5			
					1	0	0	+0.4			
					0	1	1	+0.3			
					0	1	0	+0.2			
					0	0	1	+0.1			
				0	0	0	0	±0			
					0	0	1	-0.1			
					0	1	0	-0.2			
					0	1	1	-0.3			
					1	0	0	-0.4			
					1	0	1	-0.5			
					1	1	0	-0.6			
					1	1	1	-0.7			
					Variable resistor BAL for tracking error EF balance	0	1	0		D4	D3
1	0	0	0						336kΩ	-16%	
1	0	0	1	344kΩ					-14%		
1	0	1	0	352kΩ					-12%		
1	0	1	1	360kΩ					-10%		
1	1	0	0	368kΩ					-8%		
1	1	0	1	376kΩ					-6%		
1	1	1	0	384kΩ					-4%		
1	1	1	1	392kΩ					-2%		
0	0	0	0	400kΩ					±0%		
0	0	0	1	408kΩ					+2%		
0	0	1	0	416kΩ					+4%		
0	0	1	1	424kΩ					+6%		
0	1	0	0	432kΩ					+8%		
0	1	0	1	440kΩ					+10%		
0	1	1	0	448kΩ	+12%						
0	1	1	1	456kΩ	+14%						

Note: 1. Both tracking error and focus error gains are increased by 12dB. The RFAGC block gain is also increased by 12dB.



Table 2 Serial Data Control Command 2

	DATA						Note															
	D7	D6	D5	D4	D3	D2		D1	D0													
Tracking error gain	1	0	0	—	Tracking error gain			0														
					D3	D2	D1	Gain (dB)														
					0	0	0	0														
					0	1	1	-4														
					0	1	0	-8														
					1	0	1	+7.9														
					1	1	0	+4.3														
Tracking error filter Mirror Defect	1	0	1	<table border="1"> <thead> <tr> <th colspan="3">Mirror, Defect *1</th> </tr> <tr> <th>D3</th> <th>D2</th> <th>Mode</th> </tr> </thead> <tbody> <tr> <td>0</td> <td>0</td> <td>Normal</td> </tr> <tr> <td>0</td> <td>1</td> <td>4×</td> </tr> <tr> <td>1</td> <td>1</td> <td>8×</td> </tr> </tbody> </table>			Mirror, Defect *1			D3	D2	Mode	0	0	Normal	0	1	4×	1	1	8×	0
Mirror, Defect *1																						
D3	D2	Mode																				
0	0	Normal																				
0	1	4×																				
1	1	8×																				
			D4	D1	Tracking error filter																	
			1	1	30kHz																	
			0	1	60kHz																	
			1	0	100kHz																	
			0	0	200kHz																	
APC ON FOK Vth Stand-by	1	1	0	FOK Vth		Stand-by ON	APC ON	0	Stand-by mode is cleared by setting XRST on.													
			D4	D3	Vth																	
			1	1	-12dB																	
			0	1	-6dB																	
			0	0	0dB																	
			1	0	Prohibit																	
RFEQ	1	1	1	(SC4)	(SC3)	(SC2)	(SC1)	0	*2													

Note: 1. Switches the mirror circuit and the defect circuit internal time constants at the same time. Don't use D3 = "1", D2 = "0" mode.

2. The switch name surrounded by circle means that the switch turns on when the corresponding bit is "1". This switch changes the value of the RF peaking capacitor. In case of peaking off all switches must be set off.

## RF Amplifiers

The output from PDIC is summed by RFS amplifier.

Figure 4 shows the equivalent circuit for the EQ block in figure 3. The peaking characteristics can be changed with 4-bit data from the HD49250.

On resistance of SC1 to SC4 are 600Ω Typ.

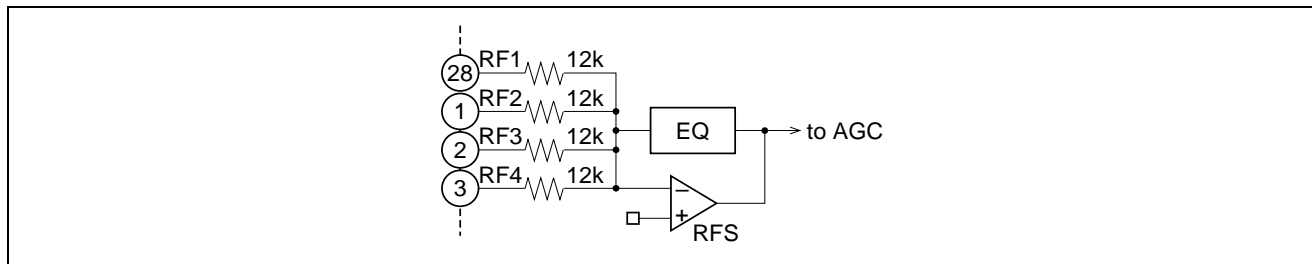

**Figure 3 RFS Amplifier**

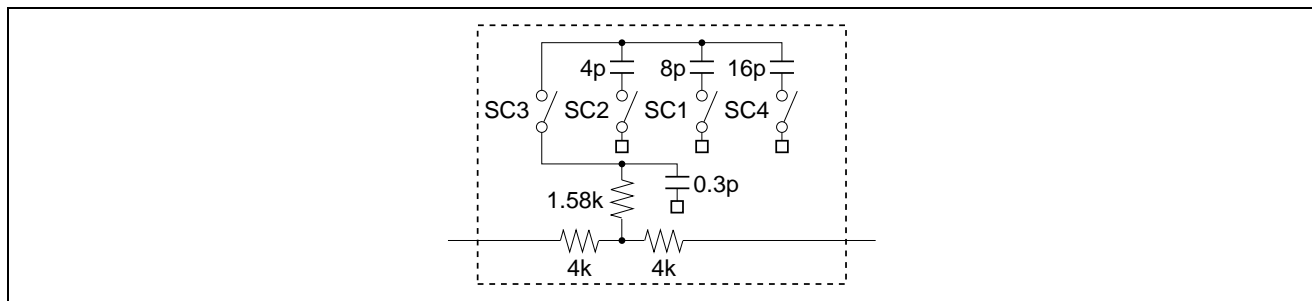

**Figure 4 RFS Amplifier Equalizer Equivalent Circuit**

The RFS amplifier output is input to the AGC amplifier internally in the IC.

Pin 24 is used to connect the capacitor that sets cut-off frequency of high-pass filter between the RFS amplifier and the AGC amplifier. The cut-off frequency will typically be 80Hz with the external constants shown in figure 5.

The RF signal is rectified by an internal resistor and an external capacitor connected to pin 23.

The pins 28, 1, 2, and 3 expect an input level of about 0.1Vpp. The AGC amplifier output (pin 22) will have an amplitude of 1.2Vpp Typ.

When CD-RW mode is set by 1-bit data from the HD49250, the AGC amplifier gain is increased by 12dB. This allows the IC to output a 1.2Vpp Typ amplitude even during CD-RW playback.

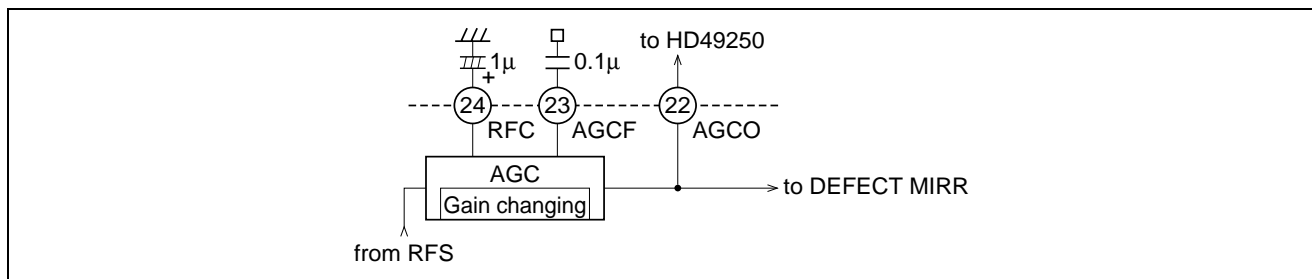

**Figure 5 AGC Amplifier**

**FOK Detection Circuit**

This detector is a comparator that generates the FOK signal. FOK is one of the signals that activate the focus servo.

The FSA amplifier ( $f_c = 53\text{kHz Typ}$ ) sums the output from the PDIC. When this output signal becomes lower than the reference voltage by  $V_{th}$ , pin 17 goes high. This  $V_{th}$  can be set by 2-bit data from the HD49250.

$V_{th}$  is set to 0.8V (0dB) after a reset.

Using  $\mu$ -com ADC & DAC the voltage of pin 11 had better be set the same voltage as the voltage of pin 10 before focus searching in order to reduce the effect of DC offset voltage at FSA amplifier output.

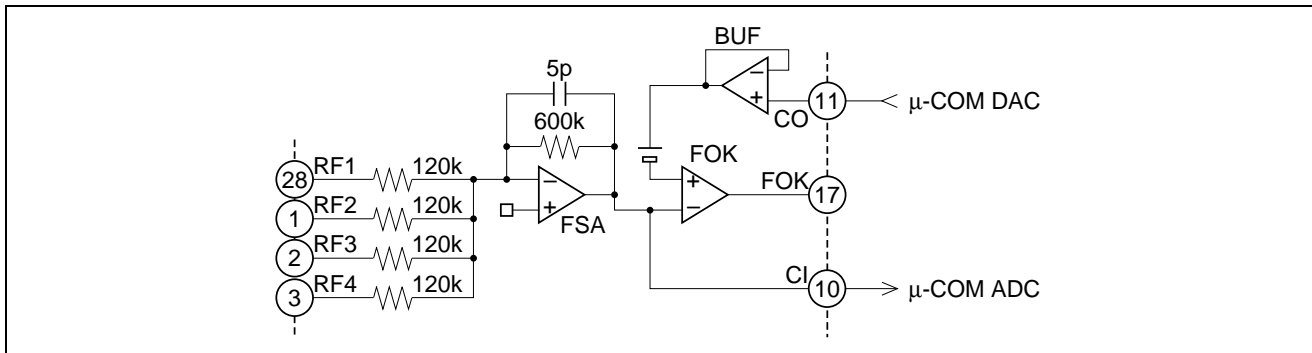

**Figure 6 FOK Detection**

**APC**

This circuit is for the Psub laser diode. This circuit is turned on or off by 1-bit data from the HD49250.

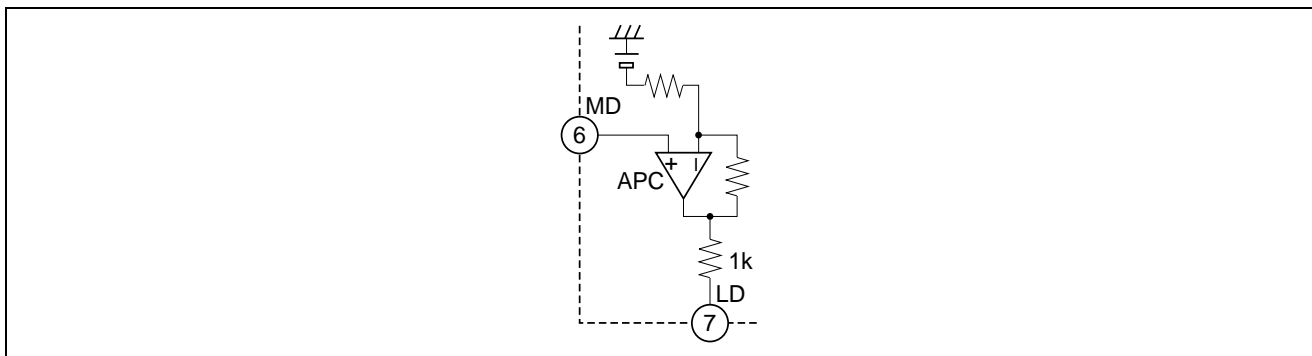

**Figure 7 APC**

# HA12220F

## Focus Error Amplifiers

The FE amplifier adds and subtracts the output from the PDIC.

FVR2 is a variable resistor used to increase the gain by 12dB in CD-RW mode. This variable resistor is set by 1-bit data from the HD49250.

FVR is a variable resistor that changes the focus error gain over the range -8 to +8dB in  $\pm 4$ dB steps. This variable resistor is set by 3-bit data from the HD49250.

An offset of between -0.7 and 0.7V (in 0.1V steps) is inserted into the focus error signal. This is set by 4-bit data from the HD49250. The FE output cut-off frequency ( $f_c$ ) is 60kHz Typ.

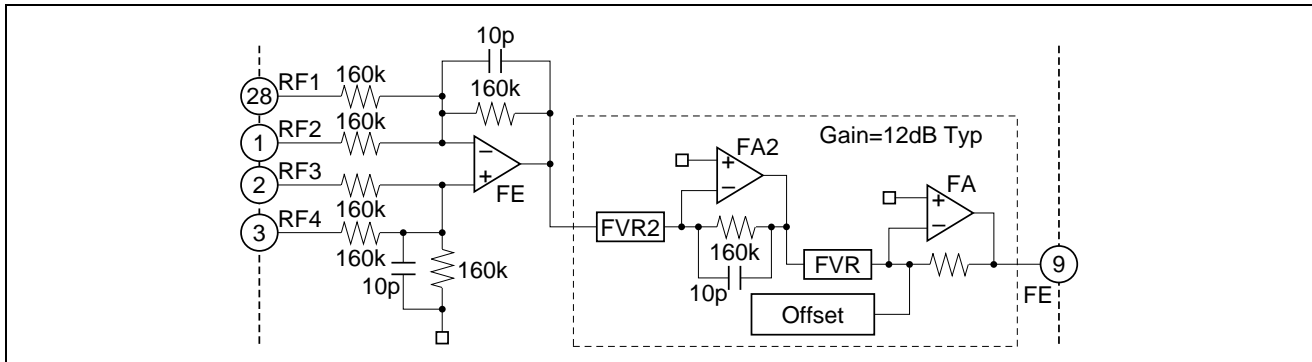

Figure 8 Focus Error Amplifiers

## Defect Detection Circuit

When a scratched disc is played, the EFM RF signal has the shape shown in figure 10 (a). The defect detection circuit detects the drop-out area of this signal.

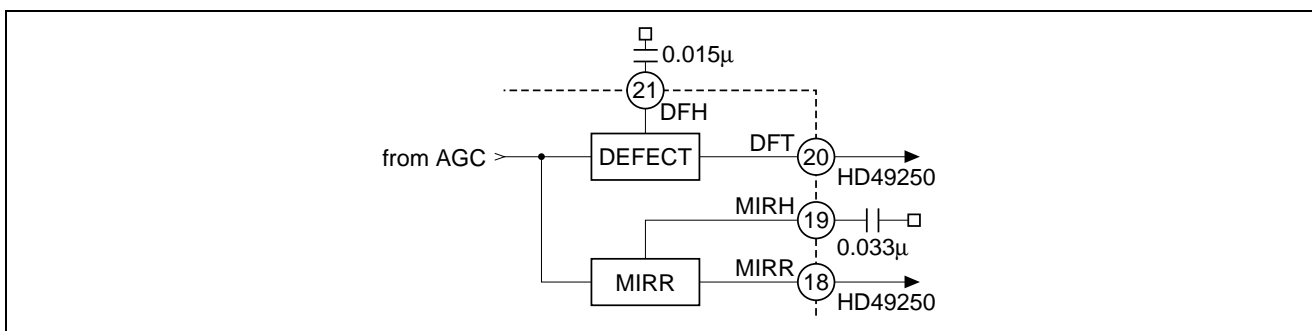

Figure 9 Mirror Detection, Defect Detection

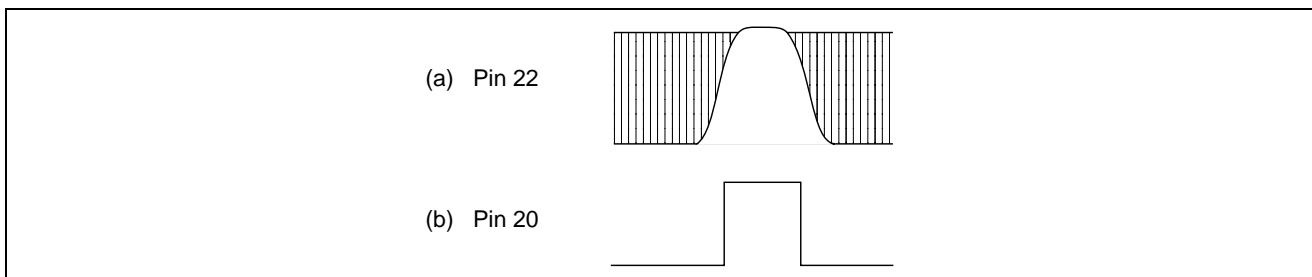

Figure 10 Defect Detection Waveform

**Mirror Detection Circuit (MIRR)**

As the pick-up travels across tracks, the EFM RF signal varies as in figure 11 (a). The mirror detection circuit detects the mirror region from this signal.

The external capacitor on pin 19 integrates the track-crossing frequency component.

The internal time constant of the mirror detection circuit can be set for normal, 4×, or 8× speed by 2-bit data from the HD49250, to raise the trackable range of track-crossing frequencies. The defect circuit internal time constant is also switched at the same time.

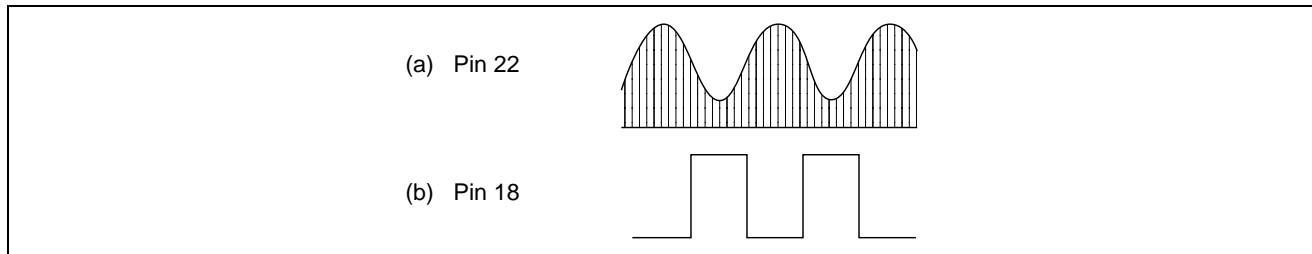

**Figure 11 Mirror Detection Waveform**

**Tracking Error Amplifiers**

The sub-beam output of PDIC is passed through a resistor and input at pins 4 and 5. External resistances of pins 4 and 5 should be set according to the pick-up so that the traverse signal at pin 8 is about 2V<sub>pp</sub> Typ. After a reset, the initial value of the feedback resistance BAL of TR1 amplifier is 400kΩ, the same as the feedback resistance of TR2 amplifier.

BAL has a variable resistance value that is changed by 4-bit data from the HD49250. The variability range here is from -16 to +14% in 2% steps. This resistance can be varied to adjust the EF balance of the tracking error.

TE amplifier generates the tracking error signal.

TVR is a resistor that changes the tracking gain from -8 to +8dB in 4dB steps. This is set by 3-bit data from the HD49250. TVR2 is a variable resistor used to increase the gain by 12dB in CD-RW mode. This variable resistor is set by 1-bit data from the HD49250.

TLPF switches the tracking error cut-off frequency. The TE output cut-off frequency is set to either 30, 60, 100, or 200kHz (Typ) by 2-bit data from the HD49250.

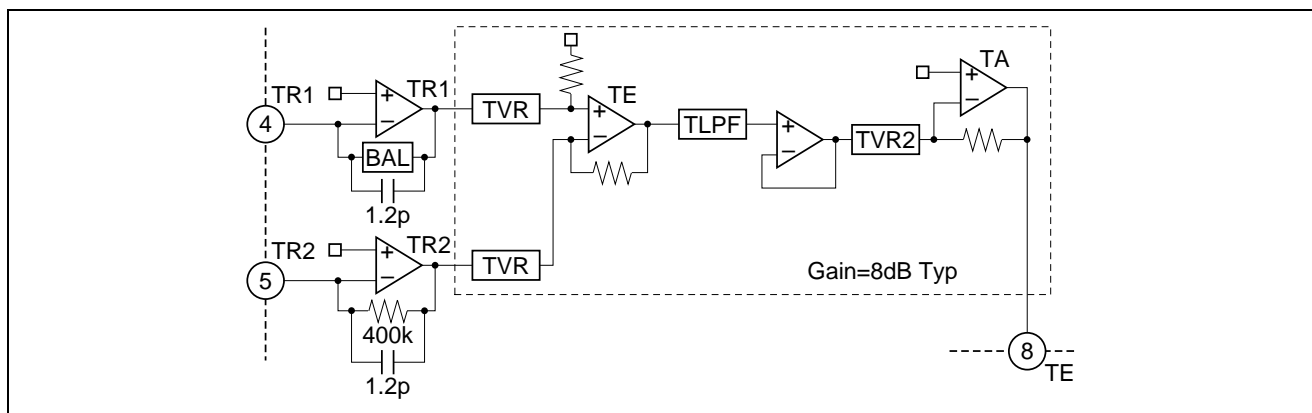

**Figure 12 Tracking Error Amplifiers**

---

# HA12220F

---

## Bias, Reference Voltage

Pin 26 is for a bypass capacitor to eliminate noise from the IC's internal bias circuits.  
Connect a capacitor to pin 25 to remove the ripple component from the reference voltage.  
The IC's internal reference voltage is connected internally.

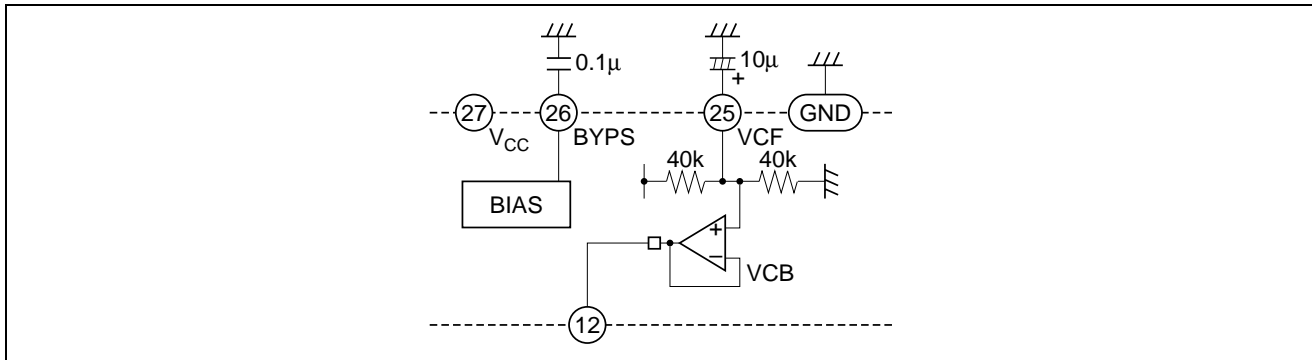

**Figure 13 Bias, Reference Voltage**

**Absolute Maximum Rating** (Ta=25°C)

<b>Item</b>	<b>Symbol</b>	<b>Rating</b>	<b>Unit</b>
Power supply voltage	V <sub>cc</sub>	6	V
Power dissipation	P <sub>T</sub>	400	mW
Operating temperature	Topr	-20 to +75	°C
Storage temperature	Tstg	-55 to +125	°C

Note: Recommended operating power supply voltage : 5V ± 0.5V

# HA12220F

## Electrical Characteristics (Ta = 25°C, V<sub>CC</sub> = 5V)

Item	Symbol	Min	Typ	Max	Unit	Test Conditions	Application Terminal	
Quiescent current 1	I <sub>CC1</sub>	—	20	32	mA	No signal	27	
Quiescent current 2	I <sub>CC2</sub>	—	0.6	1.0	mA	Stand-by mode		
Reference voltage	V <sub>C</sub>	2.3	2.5	2.7	V	I12 ≤ ±4mA	12	
Focus error amp.	Offset voltage *1	V <sub>FE</sub>	— 100	0	100	mV		9
	Max output voltage H 1	V <sub>FEH1</sub>	4.2	4.5	—	V	S2, S3, S51, S9a V51 = 4V	
	Max output voltage L 1	V <sub>FEL1</sub>	—	0.5	0.8	V	S1, S28, S51, S9a V51 = 4V	
	Max output voltage H 2	V <sub>FEH2</sub>	3.8	4.1	—	V	S2, S3, S51, S9b V51 = 4V	
	Max output voltage L 2	V <sub>FEL2</sub>	—	0.9	1.2	V	S1, S28, S51, S9b V51 = 4V	
	Voltage gain 1	G <sub>VFE1</sub>	16.0	18.0	20.0	dB	S2, S3, S50 V9/VIN50	
	Voltage gain 2	G <sub>VFE2</sub>	16.0	18.0	20.0	dB	S1, S28, S50 V9/VIN50	
Tracking error amp.	Offset voltage *1	V <sub>TE</sub>	—65	0	65	mV		8
	Max output voltage H 1	V <sub>TEH1</sub>	4.2	4.5	—	V	S4, S51, S8a V51 = 4V	
	Max output voltage L 1	V <sub>TEL1</sub>	—	0.5	0.8	V	S5, S51, S8a V51 = 4V	
	Max output voltage H 2	V <sub>TEH2</sub>	3.8	4.1	—	V	S4, S51, S8b V51 = 4V	
	Max output voltage L 2	V <sub>TEL2</sub>	—	0.9	1.2	V	S5, S51, S8b V51 = 4V	
	Voltage gain 1	G <sub>VTE1</sub>	5.0	8.0	11.0	dB	S4, S50 V8/VIN50	
	Voltage gain 2	G <sub>VTE2</sub>	5.0	8.0	11.0	dB	S5, S50 V8/VIN50	
FOK	FOK Vth	V <sub>FOK</sub>	110	160	210	mV	S28, S51 when V17 ≥ 4V Min (V51 – V12) *2	17
	“H” output voltage	V <sub>FKH</sub>	4.7	—	—	V		
	“L” output voltage	V <sub>FKL</sub>	—	—	0.4	V		

- Note: 1. All offset voltages are values referring to VC (pin 12) at reset.  
2. V11 = setting the same voltage as the voltage of pin 10 at no signal.



**Electrical Characteristics** ( $T_a = 25^\circ\text{C}$ ,  $V_{CC} = 5\text{V}$ ) (cont)

Item		Symbol	Min	Typ	Max	Unit	Test Conditions	Application Terminal
Defect	Max operation frequency	$F_{DH}$	2	—	—	kHz	S28, S1, S2, S3, S50, S23	20
	Min operation frequency	$F_{DL}$	—	—	1	kHz		
	"H" output voltage	$V_{DFH}$	4.7	—	—	V		
	"L" output voltage	$V_{DFL}$	—	—	0.4	V		
Mirror	Max operation frequency	$F_{MIR}$	200	—	—	kHz	S28, S1, S2, S3, S50, S23 8× mode	18
	"H" output voltage	$V_{MH}$	4.7	—	—	V		
	"L" output voltage	$V_{ML}$	—	—	0.4	V		
CLK DATA XLT XRST	"H" input voltage	$V_{PH}$	4.0	—	—	V		13, 14, 15, 16
	"L" input voltage	$V_{PL}$	—	—	1.0	V		
APC	APC voltage	$V_{APC}$	0.09	0.16	0.23	V		6
RFAGC	Output voltage 1	$V_{AGC1}$	0.8	1.2	1.6	Vp-p	S28, S50, f = 200kHz 0.4Vpp ± 6dB input	22
	Output voltage 2	$V_{AGC2}$	0.8	1.2	1.6	Vp-p	S1, S50, f = 200kHz 0.4Vpp ± 6dB input	
	Output voltage 3	$V_{AGC3}$	0.8	1.2	1.6	Vp-p	S2, S50, f = 200kHz 0.4Vpp ± 6dB input	
	Output voltage 4	$V_{AGC4}$	0.8	1.2	1.6	Vp-p	S3, S50, f = 200kHz 0.4Vpp ± 6dB input	
	Frequency characteristics 1	$F_{AGC1}$	—	30	—	MHz	S28, S50, S23 0.4Vpp input *3	
	Frequency characteristics 2	$F_{AGC2}$	—	30	—	MHz	S1, S50, S23 0.4Vpp input *3	
	Frequency characteristics 3	$F_{AGC3}$	—	30	—	MHz	S2, S50, S23 0.4Vpp input *3	
	Frequency characteristics 4	$F_{AGC4}$	—	30	—	MHz	S3, S50, S23 0.4Vpp input *3	

Note: 3. Setting V23 at the value of the pin 23 voltage when S28 is on,  $V_{IN50} = 0.4\text{Vpp}$ , and a 200kHz input. The frequency down -3dB from the output level for  $f = 200\text{kHz}$ .

# HA12220F

## Test Circuit

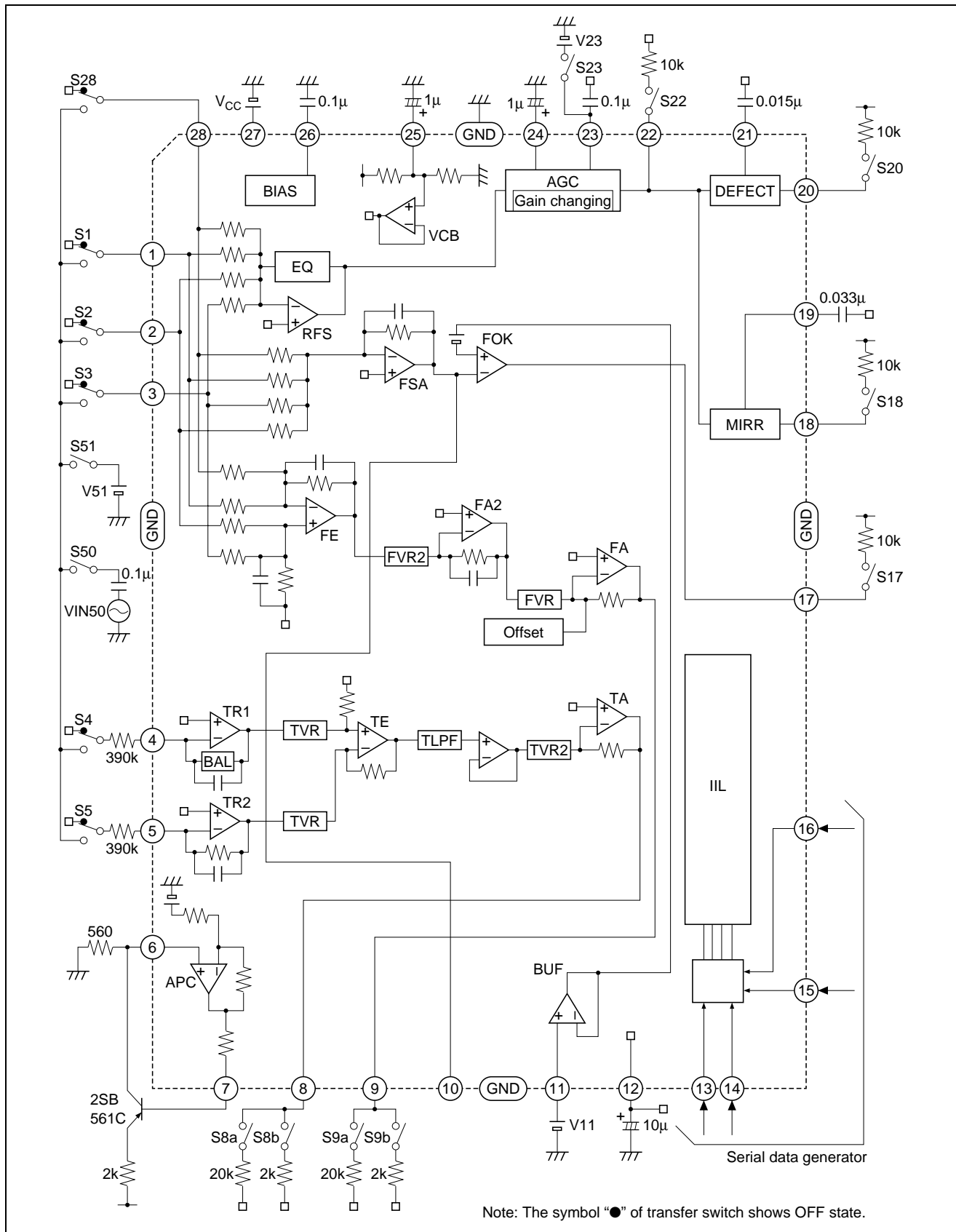

Package Dimensions

Unit: mm

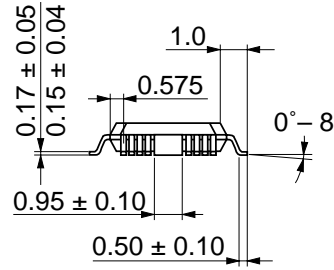
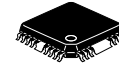
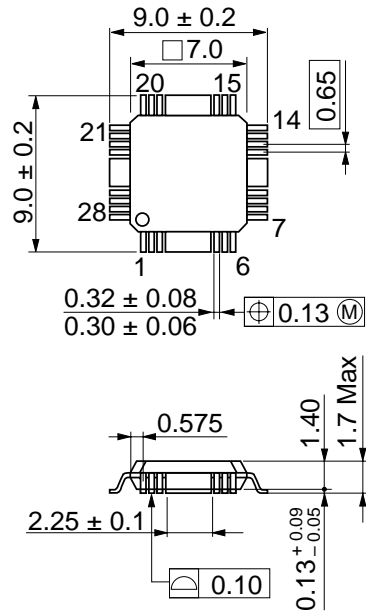

Hitachi Code	FP-28TB
JEDEC Code	—
EIAJ Code	—
Weight	0.19 g

## Disclaimer

1. Hitachi neither warrants nor grants licenses of any rights of Hitachi's or any third party's patent, copyright, trademark, or other intellectual property rights for information contained in this document. Hitachi bears no responsibility for problems that may arise with third party's rights, including intellectual property rights, in connection with use of the information contained in this document.
2. Products and product specifications may be subject to change without notice. Confirm that you have received the latest product standards or specifications before final design, purchase or use.
3. Hitachi makes every attempt to ensure that its products are of high quality and reliability. However, contact Hitachi's sales office before using the product in an application that demands especially high quality and reliability or where its failure or malfunction may directly threaten human life or cause risk of bodily injury, such as aerospace, aeronautics, nuclear power, combustion control, transportation, traffic, safety equipment or medical equipment for life support.
4. Design your application so that the product is used within the ranges guaranteed by Hitachi particularly for maximum rating, operating supply voltage range, heat radiation characteristics, installation conditions and other characteristics. Hitachi bears no responsibility for failure or damage when used beyond the guaranteed ranges. Even within the guaranteed ranges, consider normally foreseeable failure rates or failure modes in semiconductor devices and employ systemic measures such as fail-safes, so that the equipment incorporating Hitachi product does not cause bodily injury, fire or other consequential damage due to operation of the Hitachi product.
5. This product is not designed to be radiation resistant.
6. No one is permitted to reproduce or duplicate, in any form, the whole or part of this document without written approval from Hitachi.
7. Contact Hitachi's sales office for any questions regarding this document or Hitachi semiconductor products.

## Sales Offices

# HITACHI

### Hitachi, Ltd.

Semiconductor & Integrated Circuits.

Nippon Bldg., 2-6-2, Ohte-machi, Chiyoda-ku, Tokyo 100-0004, Japan

Tel: Tokyo (03) 3270-2111 Fax: (03) 3270-5109

URL      NorthAmerica      : <http://semiconductor.hitachi.com/>  
          Europe                : <http://www.hitachi-eu.com/hel/ecg>  
          Asia                    : <http://sicapac.hitachi-asia.com>  
          Japan                  : <http://www.hitachi.co.jp/Sicd/indx.htm>

### For further information write to:

Hitachi Semiconductor  
(America) Inc.  
179 East Tasman Drive,  
San Jose, CA 95134  
Tel: <1> (408) 433-1990  
Fax: <1>(408) 433-0223

Hitachi Europe GmbH  
Electronic Components Group  
Dornacher Straße 3  
D-85622 Feldkirchen, Munich  
Germany  
Tel: <49> (89) 9 9180-0  
Fax: <49> (89) 9 29 30 00  
  
Hitachi Europe Ltd.  
Electronic Components Group.  
Whitebrook Park  
Lower Cookham Road  
Maidenhead  
Berkshire SL6 8YA, United Kingdom  
Tel: <44> (1628) 585000  
Fax: <44> (1628) 585160

Hitachi Asia Ltd.  
Hitachi Tower  
16 Collyer Quay #20-00,  
Singapore 049318  
Tel: <65>-538-6533/538-8577  
Fax : <65>-538-6933/538-3877  
URL : <http://www.hitachi.com.sg>  
  
Hitachi Asia Ltd.  
(Taipei Branch Office)  
4/F, No. 167, Tun Hwa North Road,  
Hung-Kuo Building,  
Taipei (105), Taiwan  
Tel : <886>-(2)-2718-3666  
Fax : <886>-(2)-2718-8180  
Telex : 23222 HAS-TP  
URL : <http://www.hitachi.com.tw>

Hitachi Asia (Hong Kong) Ltd.  
Group III (Electronic Components)  
7/F., North Tower,  
World Finance Centre,  
Harbour City, Canton Road  
Tsim Sha Tsui, Kowloon,  
Hong Kong  
Tel : <852>-(2)-735-9218  
Fax : <852>-(2)-730-0281  
URL : <http://www.hitachi.com.hk>

Copyright © Hitachi, Ltd., 2000. All rights reserved. Printed in Japan.  
Colophon 2.0