

# CM6136

## Single-Channel Transient Voltage Suppressor

### Product Description

ON Semiconductor's CM6136 is an *Application Specific Integrated Passive™ (ASIP™)* component in a 2 x 2, 4-bump, 0.4 mm pitch, CSP form factor. This device is designed for:

- Fuse
- Transient Voltage Suppression (TVS)
- Electrostatic Discharge Protection
- Electrical Overstress Protection

### Features

- 4-Bump, 0.8 mm X 0.8 mm Footprint Chip Scale Package (CSP)
- These Devices are Pb-Free and are RoHS Compliant

**Table 1. PIN DESCRIPTIONS**

4-bump CSP Package	
Pin	Description
A1	Fuse Terminal 1
A2	TVS Channel / Fuse Terminal 2
B1 & B2	Device Ground

### PACKAGE / PINOUT DIAGRAMS

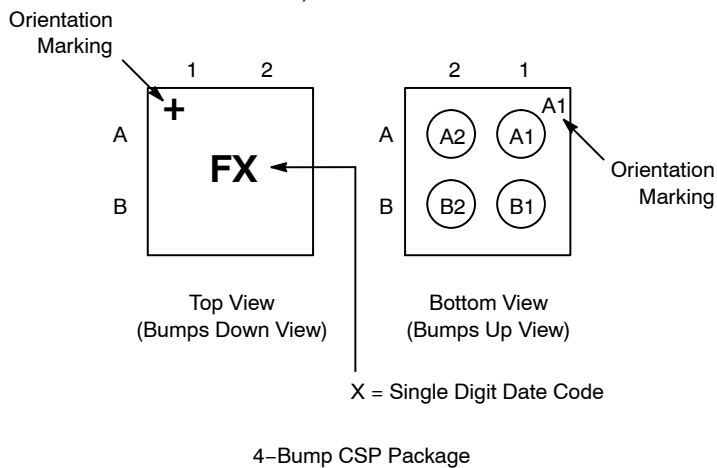

**ON Semiconductor®**

<http://onsemi.com>



**WLCSP4  
CP SUFFIX  
CASE 567CA**

### ELECTRICAL SCHEMATIC

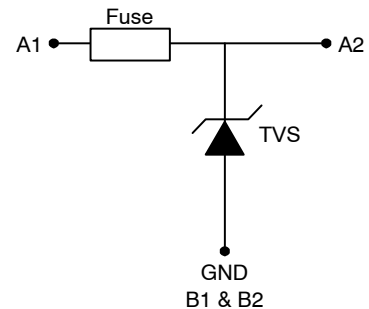

### MARKING DIAGRAM

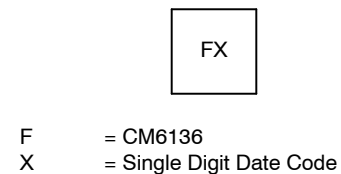

### ORDERING INFORMATION

Device	Package	Shipping†
CM6136	WLCSP4 (Pb-Free)	10,000/Tape & Reel

†For information on tape and reel specifications, including part orientation and tape sizes, please refer to our Tape and Reel Packaging Specification Brochure, BRD8011/D.

# CM6136

## ELECTRICAL SPECIFICATIONS AND CONDITIONS

**Table 2. ABSOLUTE RATINGS**

Parameter	Rating	Units
Failing to nonconductive, $I^2t$ – from <b>A1</b> pin to device ground (Maximum $I_{PP}$ value using 10/1000 $\mu$ s pulse). See Notes 1 and 2.	4	A
Failing to nonconductive, $I^2t$ – from <b>A2</b> pin to device ground (Maximum $I_{PP}$ value using 10/1000 $\mu$ s pulse). See Notes 1 and 2.	50	A

- The device must not burn to open-circuit, when the value is below maximum  $I_{PP}$ .
- This parameter is characterized at 25°C using an ON Semiconductor-specific test board.

**Table 3. PARAMETERS AND OPERATING CONDITIONS**

Parameter	Rating	Units
Storage Temperature Range	-55 to +150	°C
Operating Temperature Range	-30 to +85	°C

**Table 4. ELECTRICAL OPERATING CHARACTERISTICS** (Note 1)

Symbol	Parameter	Conditions	Min	Typ	Max	Units
R	Resistance A1 – A2	B1 and B2 floating (Note 2)			50	m $\Omega$
R <sub>OPEN</sub>	Resistance after open fuse	B1 and B2 floating	1			M $\Omega$
t <sub>FUSE</sub>	Fusing time	B1 and B2 floating; I = 5 A (Note 3)			100	ms
t <sub>LIFE</sub>	Fuse life time	B1 and B2 floating; I = 2 A (Notes 3, 4 and 9)	4000			Hours
I <sub>OFF</sub>	Stand-off quiescent current	From A1 pin to B1 and B2 pins; Stand-off voltage V <sub>OFF</sub> = 12 V			100	nA
V <sub>BR</sub>	Break down voltage	From A1 pin to B1 and B2 pins; Break down current I <sub>BR</sub> = 20 mA (Note 6)	15.5			V
V <sub>CL</sub>	Clamping voltage during transient	From A1 pin to B1 and B2 pins; Clamping current I <sub>CL</sub> = 1 A (Notes 6 and 7)			19.5	V
V <sub>F</sub>	Forward voltage	From A1 pin to B1 and B2 pins; Forward current I <sub>F</sub> = 850 mA			1.3	V
C <sub>L1</sub>	Line capacitance	V <sub>BIAS</sub> = 0 V		190		pF
C <sub>L2</sub>		V <sub>BIAS</sub> = 5 V	73	92		pF
V <sub>ESD</sub>	ESD protection peak discharge Voltage at <b>A1 pin or A2 to B1 and B2</b> a) Contact Discharge per IEC 61000-4-2 standard b) Air Discharge per IEC 61000-4-2 standard	(Note 8)	$\pm$ 30			kV
f <sub>C</sub>	Minimum attenuation Freq = 80 MHz – 1 GHz Freq = 1 – 4 GHz	R <sub>SOURCE</sub> = R <sub>LOAD</sub> = 50 $\Omega$		8 20		dB

- All parameters specified for T<sub>A</sub> = 25°C unless otherwise noted. Characterization data for DC parameters is taken from -30°C to 85°C.
- This parameter is measured using low current to avoid self-heating.
- These parameters are characterized using ON Semiconductor-specific test boards.
- Fuse is considered failed when its resistance is higher than 1  $\Omega$ .
- Cumulative distribution of V<sub>BR</sub> between 15.5 V and 16.0 V is about 4.5%.
- Transient: 8 x 20  $\mu$ s current pulse.
- Cumulative distribution of V<sub>CL</sub> between 19.0 V and 19.5 V is about 4.5%.
- Standard IEC 61000-4-2 with C<sub>Discharge</sub> = 150 pF, R<sub>Discharge</sub> = 330  $\Omega$ .
- Fuse lifetime is extrapolated from Accelerated Life Test (ALT) at 125°C.

# CM6136

## RF CHARACTERISTICS

$T_A = 25^\circ\text{C}$ , 50  $\Omega$  Environment

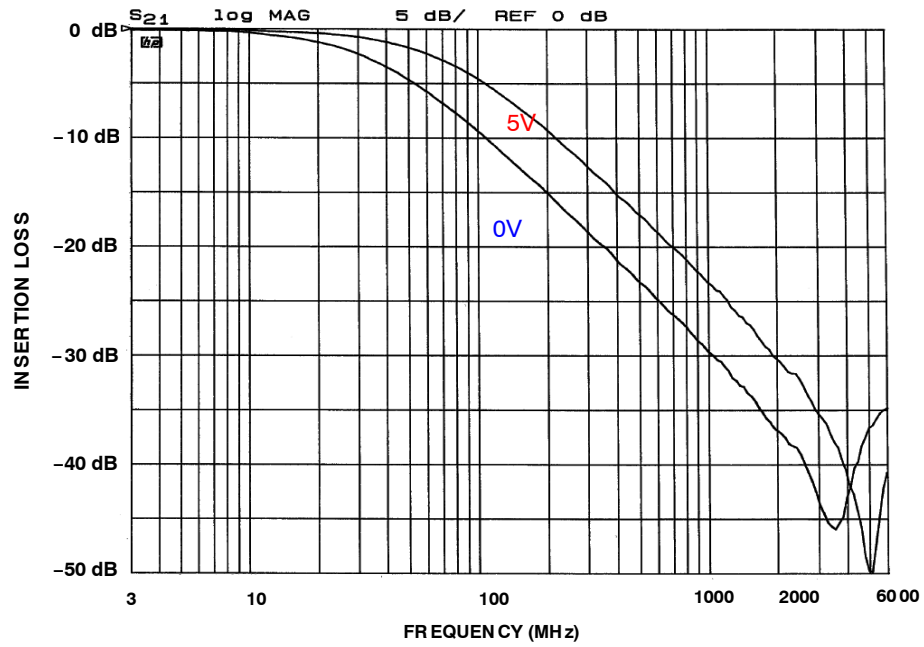
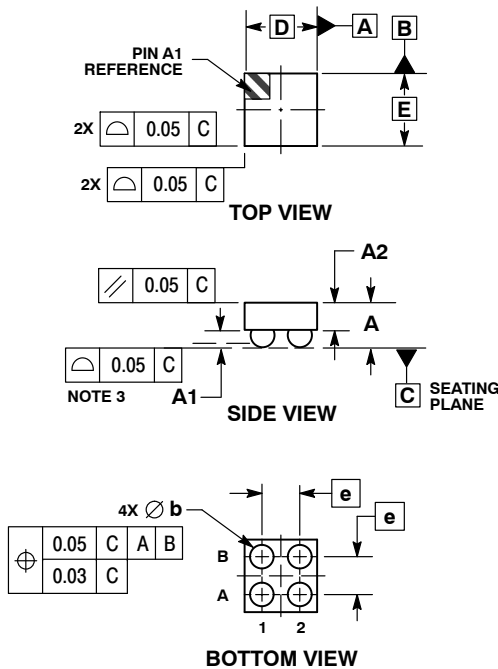

Figure 1. Insertion Loss (0 V and 5 V Bias)

# CM6136

## PACKAGE DIMENSIONS

WLCSP4, 0.8x0.8  
CASE 567CA-01  
ISSUE O



**NOTES:**

1. DIMENSIONING AND TOLERANCING PER ASME Y14.5M, 1994.
2. CONTROLLING DIMENSION: MILLIMETERS.
3. COPLANARITY APPLIES TO SPHERICAL CROWNS OF SOLDER BALLS.

DIM	MILLIMETERS	
	MIN	MAX
A	0.47	0.53
A1	0.17	0.24
A2	0.30 REF	
b	0.24	0.29
D	0.80 BSC	
E	0.80 BSC	
e	0.40 BSC	

**RECOMMENDED SOLDERING FOOTPRINT\***

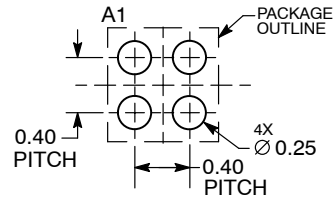

DIMENSIONS: MILLIMETERS

\*For additional information on our Pb-Free strategy and soldering details, please download the ON Semiconductor Soldering and Mounting Techniques Reference Manual, SOLDERRM/D.

Application Specific Integrated Passive is a trademark of Semiconductor Components Industries, LLC (SCILLC).

ON Semiconductor and are registered trademarks of Semiconductor Components Industries, LLC (SCILLC). SCILLC reserves the right to make changes without further notice to any products herein. SCILLC makes no warranty, representation or guarantee regarding the suitability of its products for any particular purpose, nor does SCILLC assume any liability arising out of the application or use of any product or circuit, and specifically disclaims any and all liability, including without limitation special, consequential or incidental damages. "Typical" parameters which may be provided in SCILLC data sheets and/or specifications can and do vary in different applications and actual performance may vary over time. All operating parameters, including "Typicals" must be validated for each customer application by customer's technical experts. SCILLC does not convey any license under its patent rights nor the rights of others. SCILLC products are not designed, intended, or authorized for use as components in systems intended for surgical implant into the body, or other applications intended to support or sustain life, or for any other application in which the failure of the SCILLC product could create a situation where personal injury or death may occur. Should Buyer purchase or use SCILLC products for any such unintended or unauthorized application, Buyer shall indemnify and hold SCILLC and its officers, employees, subsidiaries, affiliates, and distributors harmless against all claims, costs, damages, and expenses, and reasonable attorney fees arising out of, directly or indirectly, any claim of personal injury or death associated with such unintended or unauthorized use, even if such claim alleges that SCILLC was negligent regarding the design or manufacture of the part. SCILLC is an Equal Opportunity/Affirmative Action Employer. This literature is subject to all applicable copyright laws and is not for resale in any manner.

**PUBLICATION ORDERING INFORMATION**

**LITERATURE FULFILLMENT:**  
Literature Distribution Center for ON Semiconductor  
P.O. Box 5163, Denver, Colorado 80217 USA  
**Phone:** 303-675-2175 or 800-344-3860 Toll Free USA/Canada  
**Fax:** 303-675-2176 or 800-344-3867 Toll Free USA/Canada  
**Email:** orderlit@onsemi.com

**N. American Technical Support:** 800-282-9855 Toll Free USA/Canada  
**Europe, Middle East and Africa Technical Support:**  
Phone: 421 33 790 2910  
**Japan Customer Focus Center**  
Phone: 81-3-5773-3850

**ON Semiconductor Website:** [www.onsemi.com](http://www.onsemi.com)  
**Order Literature:** <http://www.onsemi.com/orderlit>  
For additional information, please contact your local Sales Representative