

3-phase motor driver

BA6444FP

The BA6444FP is a 3-phase, full-wave, pseudo-linear motor driver suited for VCR capstan motors. The IC has a torque ripple cancellation circuit to reduce wow and flutter, and a forced brake circuit that allows abrupt change of operational mode. The output transistor saturation prevention circuit provides superb torque control over a wide range of current. FG and hysteresis amplifiers are also built in.

●Applications

VCR capstan motors, DAT capstan motors

●Features

- 1) 3-phase, full-wave, pseudo-linear drive system.
- 2) Torque ripple cancellation circuit.
- 3) Forced brake circuit.
- 4) Output transistor (high- and low-sides) saturation prevention circuit.
- 5) FG and hysteresis amplifiers.
- 6) Thermal shutdown circuit.

●Absolute maximum ratings (Ta = 25°C)

Parameter	Symbol	Limits	Unit
Applied voltage	V _{CC}	7	V
Applied voltage	V _M	36	V
Power dissipation	P _d	1700* ¹	mW
Operating temperature	T _{opr}	-20~+75	°C
Storage temperature	T _{stg}	-40~+150	°C
Allowable output current	I _{o peak}	1500* ²	mA

*1 When mounted on a glass epoxy board (70×70×1.6 mm).

Reduced by 13.6 mW for each increase in Ta of 1°C over 25 °C.

*2 Should not exceed Pd or ASO values.

●Recommended operating conditions

Parameter	Symbol	Range	Unit
Operating power supply voltage	V _{CC}	4~6	V
	V _M	3~32* ³	V
Hall signal input voltage	Hn [±]	1.5~ (V _{CC} -1.5)	V

*3 Should not exceed ASO-value.

●Block diagram

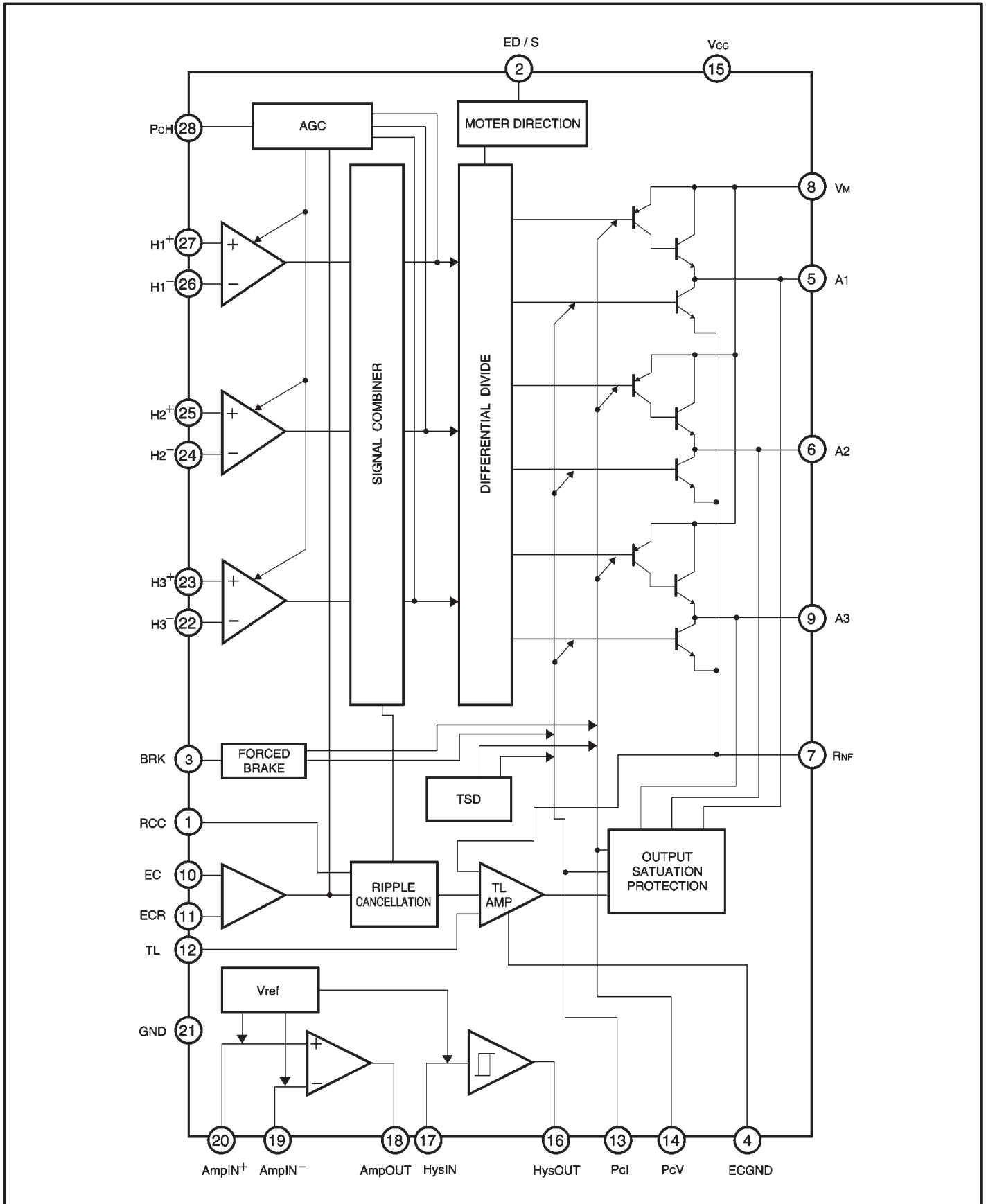

●Pin descriptions

Pin No.	Pin name	Function
1	R _{CC}	Resistor connection pin for changing the ripple cancellation ratio
2	ED / S	Forward when LOW; stop when MEDIUM; reverse when HIGH
3	BRK	Forced brake pin; brake mode when LOW
4	ECGND	Torque amplifier ground
5	A1	Motor output
6	A2	Motor output
7	R _{NF}	Motor ground; connect a resistor (0.5 Ω recommended) for current sensing
8	V _M	Motor power supply
9	A3	Motor output
10	E _C	Torque control voltage input
11	E _{CR}	Torque control reference voltage input
12	TL	Torque limit
13	P _{Cl}	Capacitor connection for phase compensation of the low-side saturation prevention circuit
14	P _{cV}	Capacitor connection for phase compensation of the high-side saturation prevention circuit
15	V _{CC}	Power supply
16	Hys OUT	Schmitt trigger amplifier output
17	Hys IN	Schmitt trigger amplifier input
18	Amp OUT	Amplifier output
19	Amp IN ⁻	Amplifier input, inverted
20	Amp IN ⁺	Amplifier input, non-inverted
21	GND	Ground
22	H ₃ ⁻	Hall signal input
23	H ₃ ⁺	Hall signal input
24	H ₂ ⁻	Hall signal input
25	H ₂ ⁺	Hall signal input
26	H ₁ ⁻	Hall signal input
27	H ₁ ⁺	Hall signal input
28	P _{cH}	Capacitor connection pin for Hall amplifier AGC circuit phase compensation

● Input/output circuits

(1) I/O circuit interface

Resistances, in Ω , are typical values. Note that the resistance values can vary $\pm 30\%$.

1) ED/S pin (2 pin)

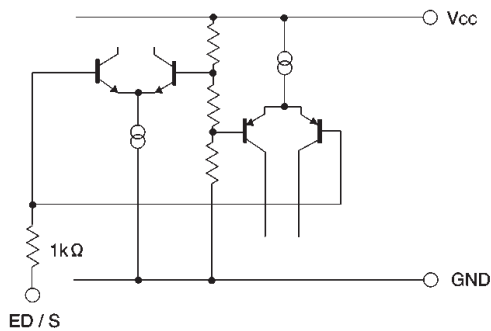

Fig.1

2) BRK pin (3 pin)

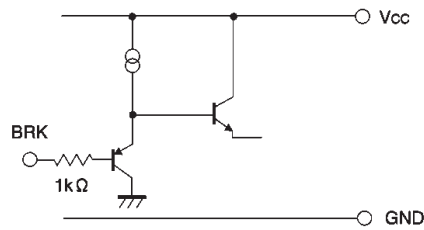

Fig.2

3) Motor output (A1: 5 pin, A2: 6 pin, A3: 9 pin)

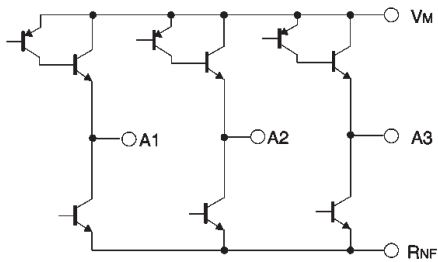

Fig.3

4) Ec and ECR pins (10 pin, 11 pin)

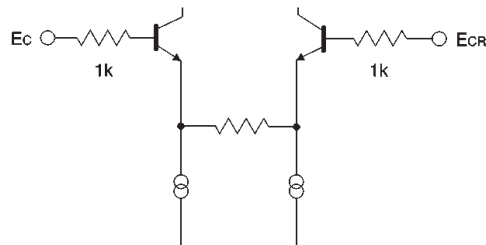

Fig.4

5) TL pin (12 pin)

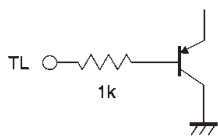

Fig.5

6) Hall signal input pins

(H1⁺: 27 pin, H1⁻: 26 pin, H2⁺: 25 pin, H2⁻: 24 pin, H3⁺: 23 pin, H3⁻: 22 pin)

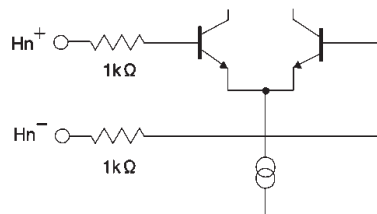

Fig.6

7) Schmitt trigger amplifier I/O pins (17 pin, 16 pin)

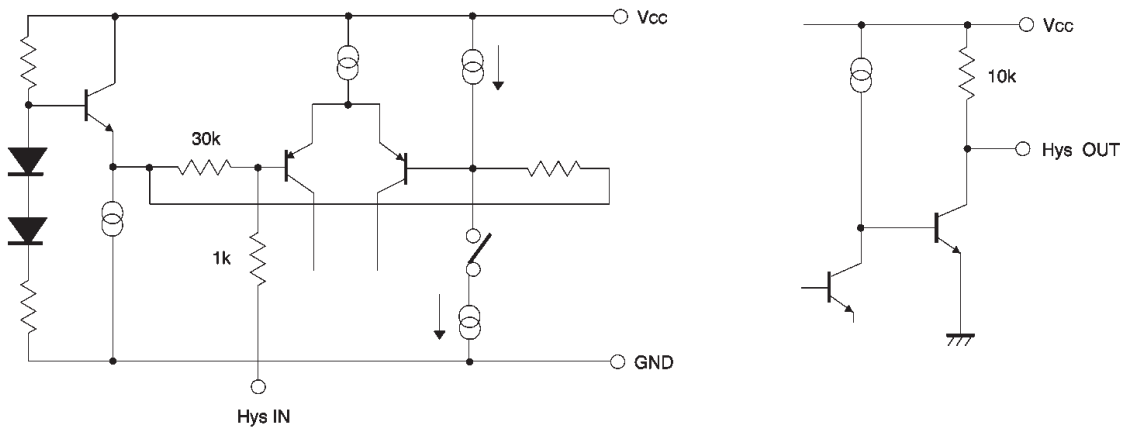

Fig.7

8) Amplifier I/O pins (20 pin, 19 pin, 18 pin)

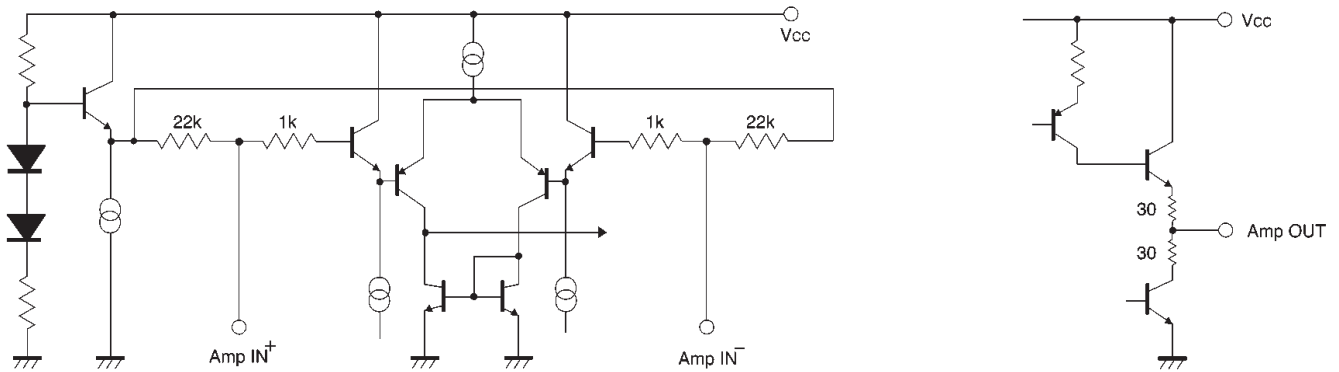

Fig.8

●Electrical characteristics (unless otherwise noted, $T_a = 25^\circ\text{C}$, $V_{CC} = 5\text{V}$, $V_M = 12\text{V}$)

Parameter	Symbol	Min.	Typ.	Max.	Unit	Conditions
Supply current	I_{CC}	—	10	15	mA	$E_C = E_{CR} - 0.1$, ED / S=M, input=(L, L, H)
Hall element input conversion offset	H_{Eofs}	-6	0	6	mV	
Hall element input conversion offset differential	ΔH_{Eofs}	0	—	8	mV	
Torque control offset	E_{Cofs}	-100	—	100	mV	
Output idle voltage	E_{Cidle}	—	0	10	mV	
Torque control input gain	G_{IO}	0.52	0.58	0.64	A / V	$E_C = 2.7 \rightarrow 2.8$, input=(L, L, H), $R_{NF} = 0.5\ \Omega$
Brake ON voltage	BR_{ON}	—	—	0.7	V	
Brake OFF voltage	BR_{OFF}	2.0	—	—	V	
Forward ON voltage	ED / F	—	—	0.9	V	
Stop ON voltage	ED / S	1.3	—	3.0	V	
Reverse ON voltage	ED / R	3.5	—	—	V	
TL- R_{NF} offset	$TL-R_{NFofs}$	38	60	88	mV	$TL = 0.35\text{V}$
Ripple cancellation ratio	V_{RCC}	3.0	3.9	4.8	%	$R_{CC} = 10\ \text{k}\Omega$, input = (L, L, H) \rightarrow (L, M, H)
Output high level voltage	V_{OH}	0.8	1.2	1.55	V	$I_O = 0.8\text{A}$
Output low level voltage	V_{OL}	1.15	1.6	2.05	V	$I_O = 0.8\text{A}$
Output current capacity	$I_{O\ Max.}$	1.4	—	—	A	$V_{CC} = 4.5\ \text{V}$, input = (H, L, M)
〈FGAMP〉						
Input impedance	R_{BA}	15.4	22	28.6	k Ω	
Open gain 1	GA 1	65	70	—	dB	$f = 500\text{Hz}$
Open gain 2	GA 2	33	38	—	dB	$f = 20\text{kHz}$
DC bias voltage	VBA	2.25	2.5	2.75	V	
Output high level voltage	$V_{OH\ A}$	3.6	4	—	V	$I_{OA} = 0.5\text{mA}$
Output low level voltage	$V_{OL\ A}$	—	0.9	1.3	V	$I_{OA} = 0.5\text{mA}$
Input voltage	VAB	1.5	—	3.8	V	
〈Schmitt trigger amplifier〉						
Hysteresis width	V_{hys}	± 115	± 155	± 195	mV	
DC bias voltage	V_{bhys}	2.25	2.5	2.75	V	
Output low level voltage	V_{OLhys}	—	100	320	mV	$I_{OLhys} = 2\text{mA}$

◎Not designed for radiation resistance.

●Circuit operation

(1) Pseudo-linear output and torque ripple cancellation
The IC generates a trapezoidal (pseudo-linear) output current, whose waveform phase is 30 degrees ahead of that of the Hall input voltage (Fig. 9).

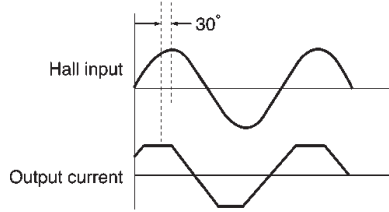

Fig. 9

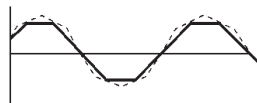

Fig.10 Torque ripple cancellation

The trapezoidal waveform of output current would create intermittence in the magnetic field generated by the 3-phase motor, and would result in an irregular rotation of the motor. To prevent this, the output waveform is obtained by superimposing a triangular wave on the trapezoidal wave (Fig. 10). This process is called torque ripple cancellation.

(2) Torque control

The output current can be controlled by adjusting the voltage applied to the torque control pins.

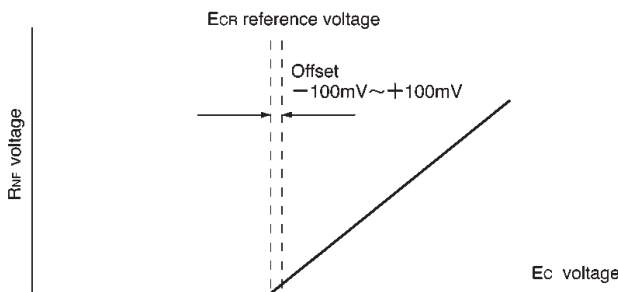

Fig.11

The pins are the inputs to a differential amplifier. A reference voltage between 2.3-3.0V (2.5V recommended) is applied to pin 11.

A brake is applied to the motor when the brake pin (pin 3) is put to LOW. The brake mode is activated when the brake pin voltage is 0.7V or less and deactivated when the voltage is 2.0V or more.

(3) Output current sensing and torque limitation

The R_{NF} pin (pin 7) is the ground pin for the output stage. To sense the output current, a resistor (0.5Ω recommended) is connected between pin 7 and the ground.

The output current is sensed by applying the voltage developed across this resistor to the TL amplifier input as a feedback.

The output current can be limited by adjusting the voltage applied to pin 12. The current is limited when pin 12 reaches the same potential as pin 7. The output current (I_{MAX.}) under this condition is given by:

$$I_{MAX.} = \frac{V_{TL} - (TL - R_{NF} \text{ offset})}{R_{RNF}}$$

where R_{RNF} is the value of the resistor connected between the R_{NF} and ground pins and V_{TL} is the voltage applied to the TL pin.

(4) Motor direction control (ED/S pin)

The motor mode is:

Forward when the ED/S-pin voltage is less than 0.9V,
Stop when the voltage is between 1.3 ~ 3.0V,
Reverse when the voltage is above 3.5V.

In the stop mode, high- and low-side output transistors are turned off, resulting in a high impedance state.

(5) Output transistor saturation prevention circuit

This circuit monitors the output voltage and maintain the operation of the output transistors below their saturation levels. Operating the transistors in the linear characteristic range provides good control over a wide range of current and good torque characteristics even during overloading.

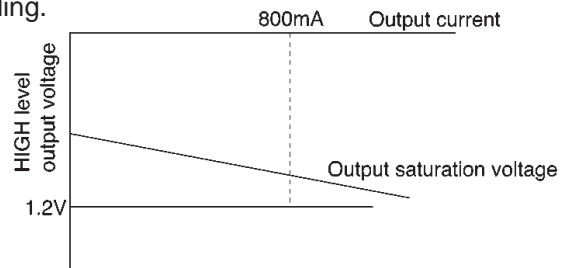

Fig.12 Transistor HIGH level output voltage

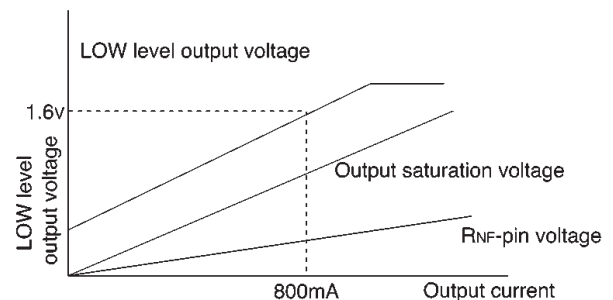

Fig.13 Transistor LOW level output voltage

(6) Ripple cancellation circuit

The cancellation ratio of the torque ripple cancellation circuit (Fig. 10) can be adjusted by an external resistor connected to pin 1. Select a suitable value by taking wow and flutter into consideration.

The ripple cancellation ratio can be obtained in the following manner. With $E_c = 2.7V$, the R_{NF} value for the Hall input of $(H1^+, H2^+, H3^+) = (L, L, H)$ is denoted as V_1 , and the R_{NF} value for the Hall input of $(H1^+, H2^+, H3^+) = (L, M, H)$ is denoted as V_2 . The ripple cancellation ratio is then given by:

$$R_{CC} = \frac{V_2 - V_1}{(V_1 + V_2)/2} \times 100 (\%)$$

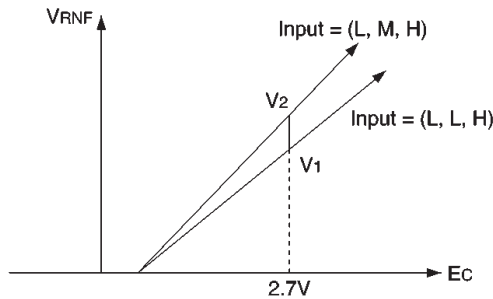

Fig.14

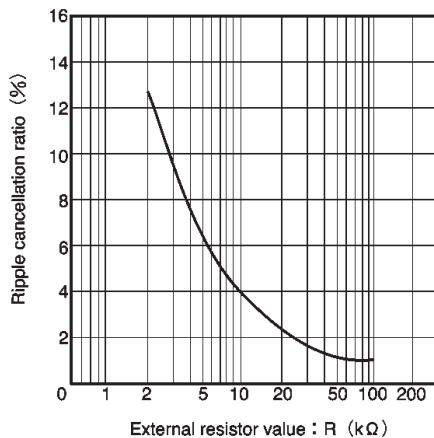

Fig.15 Ripple cancellation ratio vs. external resistor value (reference curve)

(7) Brake pin

The brake pin threshold depends on the chip temperature as shown in Fig. 16. Make sure that your application will work properly when using the IC at low or high temperatures.

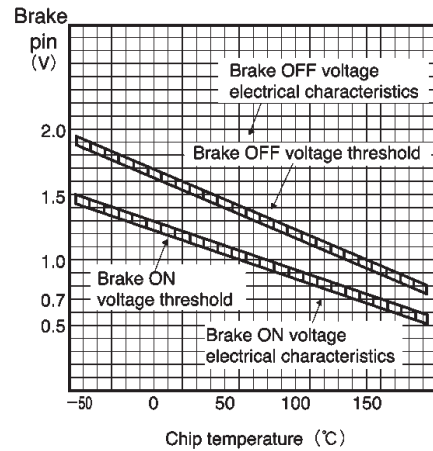

Fig.16 Brake pin threshold vs. chip temperature

●Application example

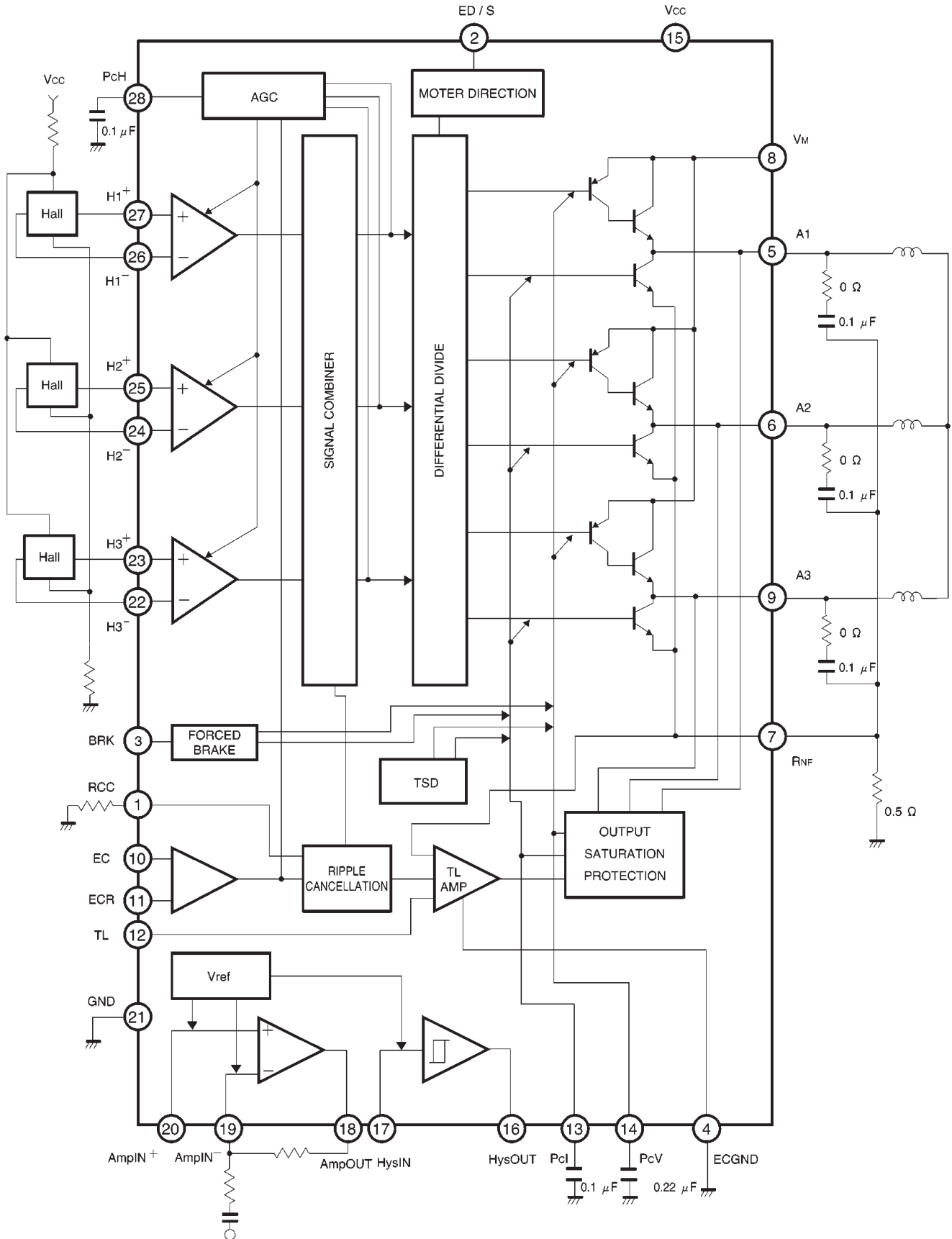

Fig.17

●Operation notes

(1) Thermal shut down circuit

The BA6444FP has a thermal shutdown circuit to protect the IC. The shutdown temperatures is 175°C (typical) with a hysteresis width of 45°C (typical).

When the circuit is activated due to an increased in chip temperature, the output pins (pins 5, 6 and 9) are set to the open state. The circuit is functional against excessive power dissipation, output short-circuiting, and other irregularities in the output current, but does not work against overheating caused by high internal currents due to externally caused IC damage or pin-to-pin short-circuiting.

(2) The brake circuit has temperature-dependent thresholds as shown in Fig. 16. Make sure that your application will work properly when using the IC at low or high temperatures.

(3) Be sure to connect the radiation fin to the ground.

(4) Hall input

The Hall input circuit is described in (6) of "I/O equivalent circuits." Hall devices can be connected in either series or parallel. Be sure to keep the Hall input within the range of 1.5V to (V_{CC} - 1.5V).

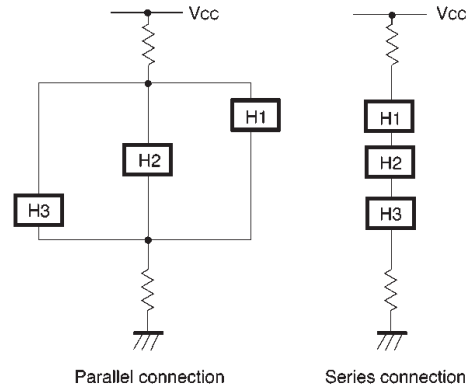

Fig.18

(5) FG amplifier

Note that unpredictable outputs may occur when the FG amplifier input is outside the recommended range.

(6) ECGND pin (pin 4)

Pin 4, a torque amplifier ground pin, should be connected to the ground. By connecting this pin to a point close to the motor ground, you can prevent the effect of GND common impedance on the current-sensing resistor (0.5Ω recommended) connected between R_{NF} (pin 7) and the motor ground pin.

●Electrical characteristic curves

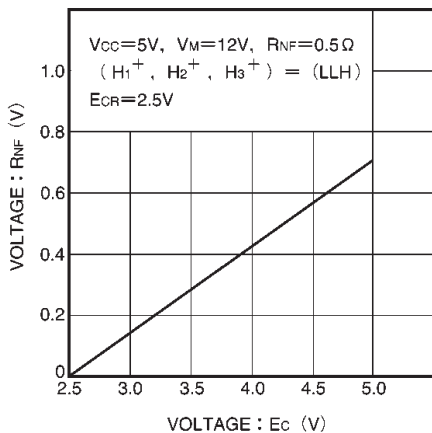

Fig.19 Output voltage vs. torque control voltage

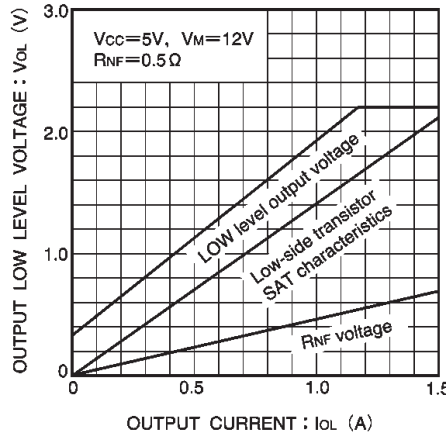

Fig.20 Output low level voltage vs. output current

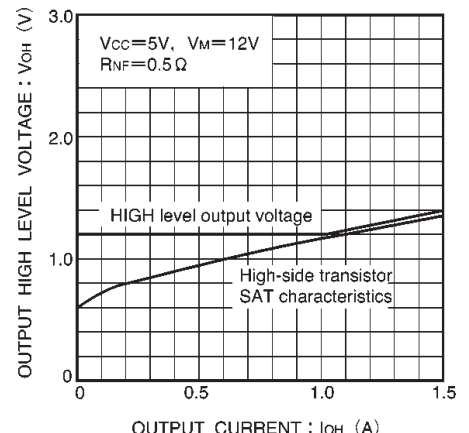

Fig.21 Output high level voltage vs. output current

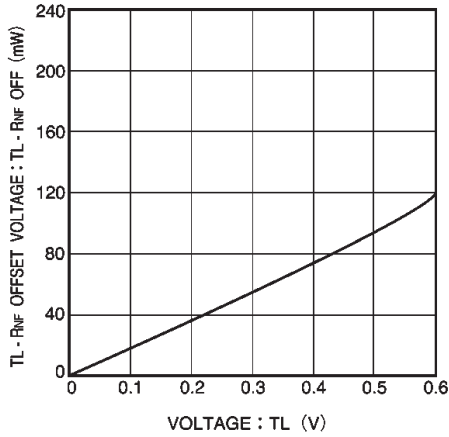

Fig.22 TL-RNF offset voltage vs. TL voltage

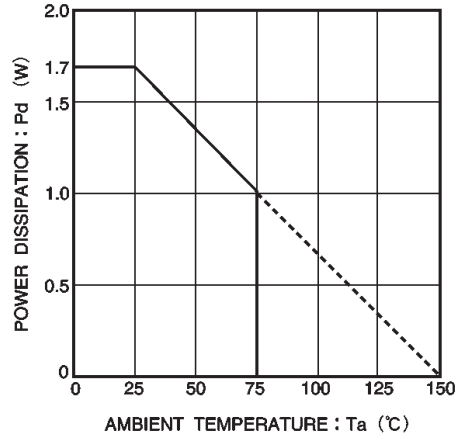

Fig.23 Power dissipation vs. ambient temperature

● External dimensions (Units: mm)

