

SRAM

128K X 8 LOW POWER CMOS STATIC RAM

FEATURES

- Low-power consumption
 - Active: 40mA at 55ns
 - Stand-by: (CMOS input/output)
 - 0 ~ +70 °C = 15uA
 - 40 ~ +85 °C = 20uA
- 55/70/100 ns access time
- Equal access and cycle time
- Single +5V (±10%) Power Supply
- TTL compatible , Tri-state output
- Common I/O capability
- Automatic power-down when deselected
- Available in 32-pin SOP ,TSOP-I(8x20mm), TSOP-I(8x13.4mm) and DIP (600 mil) package.

PART NUMBER EXAMPLES

| PART NO. | PACKAGE CODE | Operating Temperature |
|-----------------|------------------|-----------------------|
| T15M1024A-55D | D=SOP | 0 ~ +70 °C |
| T15M1024A-70H | H=TSOP-I(8x20) | |
| T15M1024A-100P | P=TSOP-I(8x13.4) | |
| T15M1024A-100N | N=DIP (600 mil) | |
| T15M1024A-55DI | D=SOP | -40 ~ +85 °C |
| T15M1024A-70HI | H=TSOP-I(8x20) | |
| T15M1024A-100PI | P=TSOP-I(8x13.4) | |
| T15M1024A-100NI | N=DIP (600 mil) | |

GENERAL DESCRIPTION

The T15M1024A is a very Low Power CMOS Static RAM organized as 131,072 words by 8 bits. That operates on a wide voltage range from +5V (±10%) power supply, Fabricated using high performance CMOS technology, Inputs and three-state outputs are TTL compatible and allow for direct interfacing with common system bus structures. Data retention is guaranteed at a power supply voltage as low as 1.5V.

BLOCK DIAGRAM

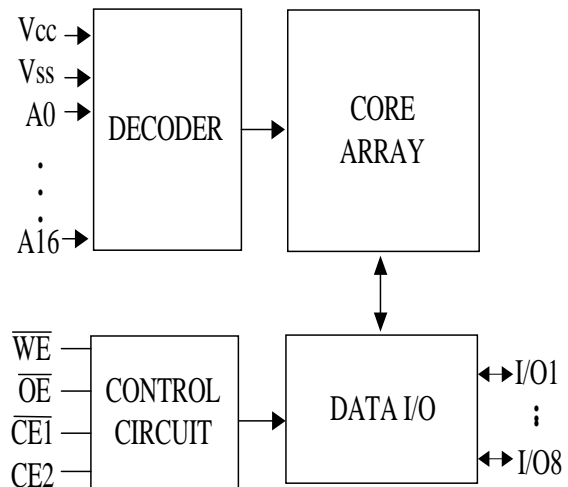

PIN CONFIGURATIONS

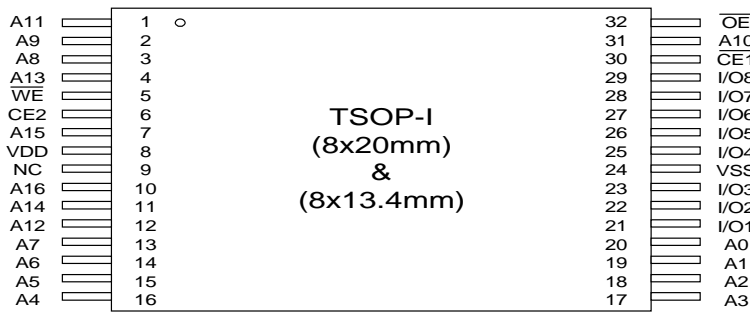
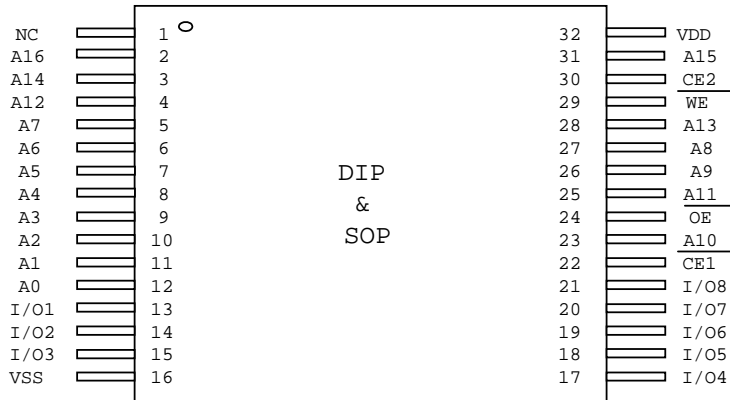

PIN DESCRIPTIONS

| SYMBOL | DESCRIPTIONS | SYMBOL | DESCRIPTIONS |
|---|---------------------|------------------------|---------------------|
| A0 ~ A16 | Address inputs | $\overline{\text{OE}}$ | Output enable input |
| I/O1~I/O8 | Data inputs/outputs | VDD | Power supply |
| $\overline{\text{CE1}}$, $\overline{\text{CE2}}$ | Chip enable | VSS | Ground |
| $\overline{\text{WE}}$ | Write enable input | NC | No connection |

ABSOLUTE MAXIMUM RATINGS*

| PARAMETER | SYM | MIN. | MAX. | UNIT |
|------------------------------------|-------------------|-------|---------|------|
| Voltage on Any Pin Relative to Gnd | V _R | -0.5 | +7 V | V |
| Power Dissipation | P _D | - | 0.7 | W |
| Storage Temperature | T _{STG} | -55 | +150 | °C |
| Temperature Under Bias | I _{BIAS} | 0/-40 | +70/+85 | °C |

*Note: Stresses greater than those listed above Absolute Maximum Ratings may cause permanent damage to the device. This is a stress rating only and function operation of the device at these or any other conditions outside those indicated in the operational sections of this specification is not implied. Exposure to absolute maximum rating conditions for extended periods may affect reliability.

TRUTH TABLE

| CE1 | CE2 | WE | OE | DATA | MODE |
|-----|-----|----|----|----------|------------------------|
| H | X | X | X | High-Z | Standby |
| X | L | X | X | High-Z | Standby |
| L | H | H | L | Data Out | Active, Read |
| L | H | H | H | High-Z | Active, Output Disable |
| L | H | L | X | Data In | Active, Write |

*Note: X = Don't Care, L = Low, H = High

OPERATING CHARACTERISTICS

 (V_{CC} = +5V / ±10%, Gnd = 0V, Ta = 0 ~ +70 °C / -40°C ~ 85°C)

| PARAMETER | SYM. | TEST CONDITIONS | -55 | | -70 | | -100 | | UNIT | |
|---|------------------|--|---------------------|-----|-----|-----|------|-----|------|----|
| | | | Min | Max | Min | Max | Min | Max | | |
| Input Leakage Current | I _{LI} | V _{CC} = Max, V _{IN} = Gnd to V _{CC} | - | 1 | - | 1 | - | 1 | uA | |
| Output Leakage Current | I _{LO} | $\overline{CE1} = V_{IH}$ or CE2 = V _{IL} or $\overline{OE} = V_{IH}$ or $\overline{WE} = V_{IL}$ V _{OUT} = Gnd to V _{CC} | - | 1 | - | 1 | - | 1 | uA | |
| Operating Power Supply Current | I _{CC} | $\overline{CE1} = V_{IL}$, CE2 = V _{IH} , $\overline{WE} = V_{IH}$, $\overline{OE} = V_{IH}$, V _{IN} = V _{IH} or V _{IL} , I _{OUT} = 0mA | - | 2 | - | 2 | - | 2 | mA | |
| Average Operating Current | I _{CC1} | Cycle time = 1us, 100% duty, I _{OUT} = 0mA, $\overline{CE1} \leq 0.2V$, CE2 ≥ V _{CC} - 0.2V, V _{IN} ≤ 0.2V | - | 3 | - | 3 | - | 3 | mA | |
| | I _{CC2} | Cycle time = min, 100% duty, I _{OUT} = 0mA, $\overline{CE1} = V_{IL}$, CE2 = V _{IH} , V _{IN} = V _{IH} or V _{IL} | - | 40 | - | 35 | - | 25 | mA | |
| Standby Power Supply Current (TTL Level) | I _{SB} | $\overline{CE1} = V_{IH}$ CE2 = V _{IL} | - | 0.5 | - | 0.5 | - | 0.5 | mA | |
| Standby Power Supply Current (CMOS Level) | I _{SB1} | $\overline{CE1} \geq V_{CC} - 0.2V$, CE2 ≥ V _{CC} - 0.2V or CE2 ≤ 0.2V V _{IN} ≤ 0.2V or V _{IN} ≥ V _{CC} - 0.2V | 0°C to 70°C | - | 15 | - | 15 | - | 15 | uA |
| | | | -40°C to 85°C | - | 20 | - | 20 | - | 20 | |
| Output Low Voltage | V _{OL} | I _{OL} = 2.1mA | - | 0.4 | - | 0.4 | - | 0.4 | V | |
| Output High Voltage | V _{OH} | I _{OH} = -1.0 mA | 2.4 | - | 2.4 | - | 2.4 | - | V | |

RECOMMENDED OPERATING CONDITIONS

(Ta = 0 ~ +70 °C / -40°C to 85°C**)

| PARAMETER | SYM | MIN | MAX | UNIT |
|----------------|-----------------|--------------------|----------------------|------|
| Supply Voltage | V _{cc} | 4.5 | 5.5 | V |
| | Gnd | 0.0 | 0.0 | V |
| Input Voltage | V _{IH} | 0.6V _{cc} | V _{cc} +0.3 | V |
| | V _{IL} | -0.3 | 0.4 | V |

CAPACITANCE

(f = 1 MHz, Ta = 25°C,)

| PARAMETER | SYMBOL | CONDITION | MAX. | UNIT |
|---------------------------|------------------|---|------|------|
| Input Capacitance | C _{IN} | V _{IN} = 0V | 6 | pF |
| Input/ Output Capacitance | C _{I/O} | V _{IN} = V _{OUT} = 0V | 8 | pF |

Note: This parameter is guaranteed by device characterization and is not production tested.

AC TEST CONDITIONS

| PARAMETER | CONDITIONS |
|---|---|
| Input Pulse Levels | 0.4V to 0.6V _{cc} |
| Input Rise and Fall Times | 5.0 ns |
| Input and Output Timing Reference Level | 1.5V |
| Output Load | C _L = 30pF + 1TTL Load (55ns/70ns) |
| | C _L = 100pF + 1TTL Load (Load for 100ns) |

AC TEST LOADS AND WAVEFORM

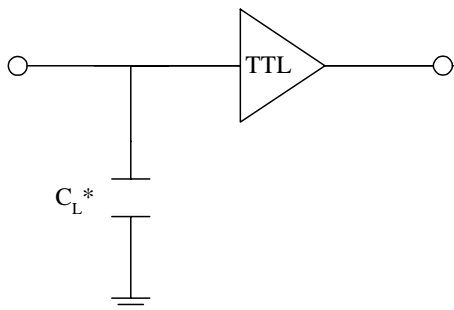

Fig.A * Including Scope and Jig Capacitance

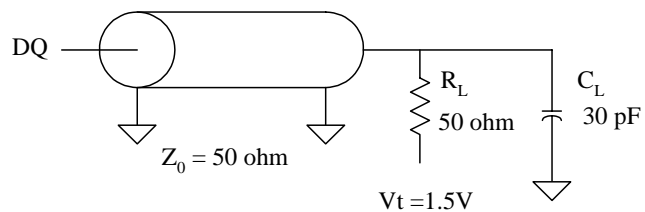

Fig.B Output Load Equivalent

AC CHARACTERISTICS

 (V_{cc} = +5V / ±10%, Gnd = 0V, Ta = 0 ~ +70 °C / -40°C to 85°C)

(1) READ CYCLE

| PARAMETER | SYM. | -55 | | -70 | | -100 | | UNIT |
|------------------------------------|------------------|-----|-----|-----|-----|------|-----|------|
| | | Min | Max | Min | Max | Min | Max | |
| Read Cycle Time | t _{RC} | 55 | - | 70 | - | 100 | - | ns |
| Address Access Time | t _{AA} | - | 55 | - | 70 | - | 100 | ns |
| Chip Enable Access Time | t _{ACE} | - | 55 | - | 70 | - | 100 | ns |
| Output Enable Access Time | t _{OE} | - | 25 | - | 35 | - | 50 | ns |
| Output Hold from Address Change | t _{OH} | 10 | - | 10 | - | 10 | - | ns |
| Chip Enable to Output in Low-Z | t _{LZ} | 10 | - | 10 | - | 10 | - | ns |
| Chip Disable to Output in High-Z | t _{HZ} | - | 20 | - | 25 | - | 30 | ns |
| Output Enable to Output in Low-Z | t _{OLZ} | 5 | - | 5 | - | 5 | - | ns |
| Output Disable to Output in High-Z | t _{OHZ} | - | 20 | - | 25 | - | 30 | ns |

(2) WRITE CYCLE

| PARAMETER | SYM. | -55 | | -70 | | -100 | | UNIT |
|----------------------------------|------------------|-----|-----|-----|-----|------|-----|------|
| | | Min | Max | Min | Max | Min | Max | |
| Write Cycle Time | t _{WC} | 55 | - | 70 | - | 100 | - | ns |
| Chip Enable to Write End | t _{CW} | 50 | - | 60 | - | 80 | - | ns |
| Address Valid to Write End | t _{AW} | 50 | - | 60 | - | 80 | - | ns |
| Address Setup Time | t _{AS} | 0 | - | 0 | - | 0 | - | ns |
| Write Pulse Width | t _{WP} | 45 | - | 50 | - | 70 | - | ns |
| Write Recovery Time | t _{WR} | 0 | - | 0 | - | 0 | - | ns |
| Data Valid to Write End | t _{DW} | 25 | - | 30 | - | 40 | - | ns |
| Data Hold Time | t _{DH} | 0 | - | 0 | - | 0 | - | ns |
| Write Enable to Output in High-Z | t _{WHZ} | - | 25 | - | 25 | - | 30 | ns |
| Output Active from Write End | t _{OW} | 5 | - | 5 | - | 5 | - | ns |

TIMING WAVEFORMS

READ CYCLE 1

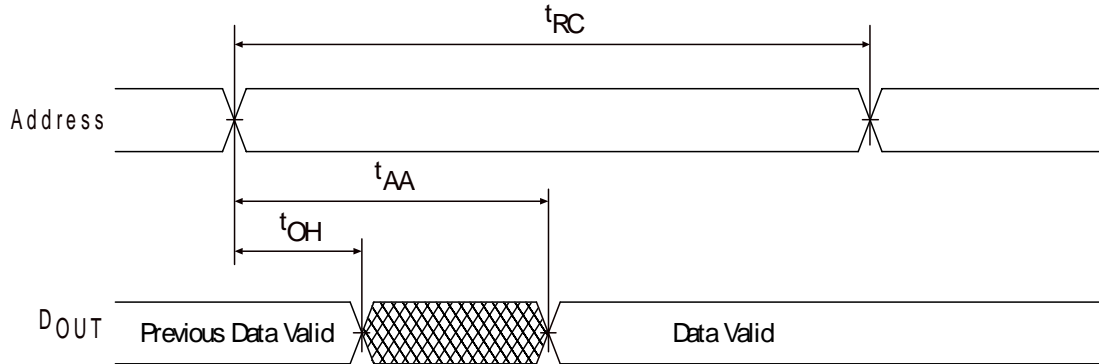

(Address Controlled)

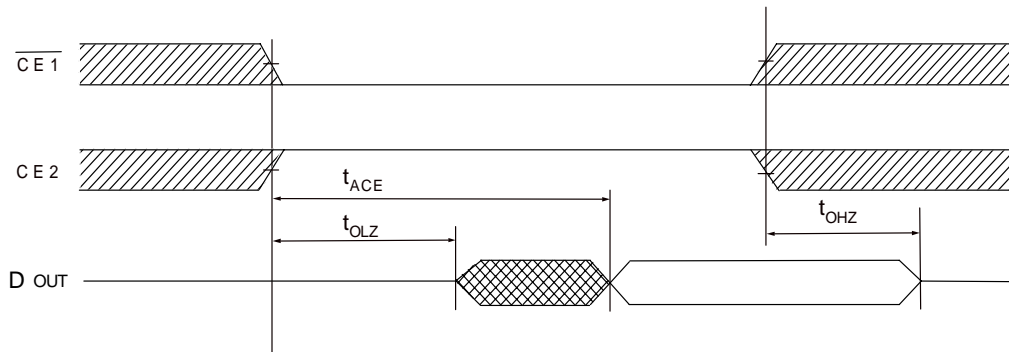

READ CYCLE 2

(Chip Enable Controlled)



 DON'T CARE
 UNDEFINED

Notes (READ CYCLE) :

1. \overline{WE} are high for read cycle.
2. All read cycle timing is referenced from the last valid address to the first transition address.
3. t_{HZ} and t_{OHZ} are defined as the time at which the outputs achieve the open circuit condition referenced to V_{OH} or V_{OL} levels.
4. At any given temperature and voltage condition. t_{HZ} (max.) is less than t_{LZ} (min.) both for a given device and from device to device interconnection.
5. Transition is measured $\pm 200mV$ from steady state voltage with load. This parameter is sampled and not 100% tested.
6. Device is continuously selected with $\overline{CE1} = V_{IL}$.

WRITE CYCLE 1 (\overline{WE} Controlled)

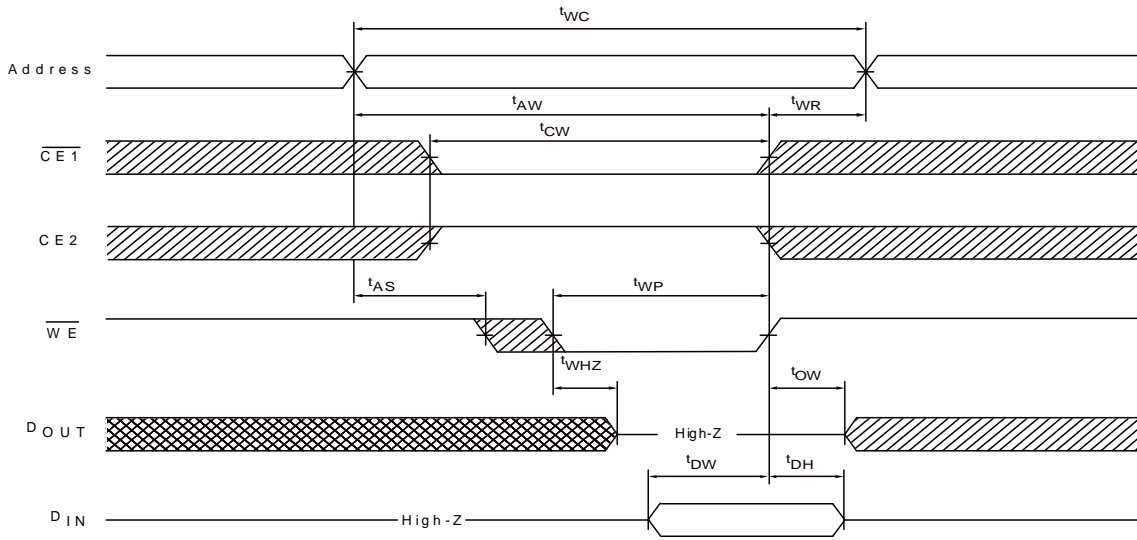

WRITE CYCLE 2 (\overline{CE} Controlled)

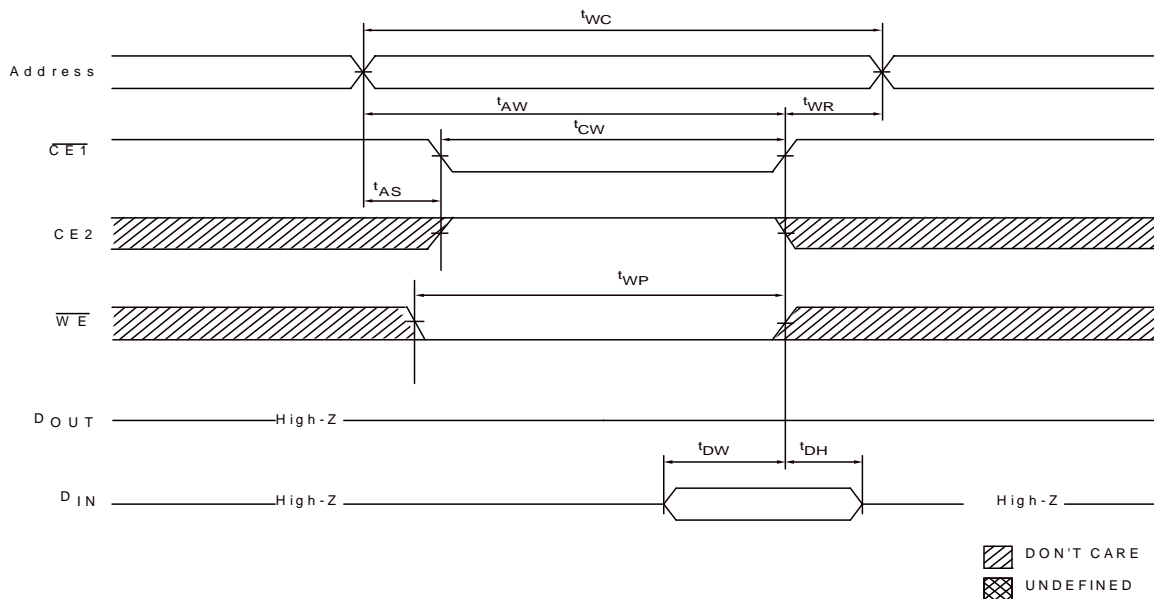

NOTES (WRITE CYCLE) :

1. A write occurs during the overlap of a low $\overline{CE1}$, a high $\overline{CE2}$ and a low \overline{WE} . A write begins at the latest transition among $\overline{CE1}$ going low, $\overline{CE2}$ going high and \overline{WE} going low. A write ends at the earliest transition among $\overline{CE1}$ going high, $\overline{CE2}$ going low and \overline{WE} going high. t_{WP} is measured from the beginning of write to the end of write.
2. t_{CW} is measured from the later of $\overline{CE1}$ going low or $\overline{CE2}$ going high to the end of write.
3. t_{AS} is measured from the address valid to the beginning of write.
4. t_{WR} is measured from the end of write to the address change.

DATA RETENTION CHARACTERISTICS

| PARAMETER | SYM. | TEST CONDITION | MIN. | MAX. | UNIT |
|--------------------------------------|-------------------|-------------------------------------|-----------------|------|------|
| V _{CC} for Data Retention | V _{DR} | $\overline{CE1} \geq V_{DD} - 0.2V$ | 1.5 | - | V |
| Data Retention Current | I _{CCDR} | $CE2 \leq 0.2V$ | - | 5* | uA |
| Chip Deselect to Data Retention Time | t _{CDR} | $V_{IN} \geq V_{CC} - 0.2V$ or | 0 | - | ns |
| Operation Recovery Time | t _R | $V_{IN} \leq 0.2V$ | t _{RC} | - | ns |

* 0 ~ +70 °C / -40 ~ +85 °C, V_{CC}=3V

DATA RETENTION WAVEFORM

(Ta = 0 ~ +70 °C / -40°C to 85°C)

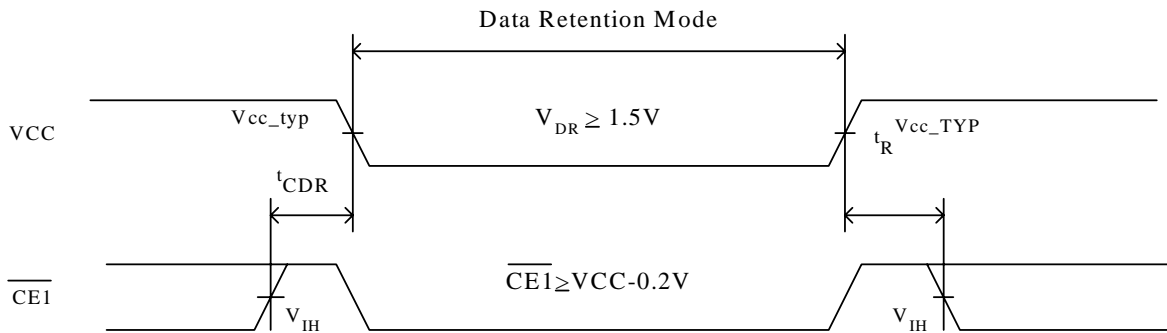

PACKAGE DIMENSIONS
32-LEAD SOP

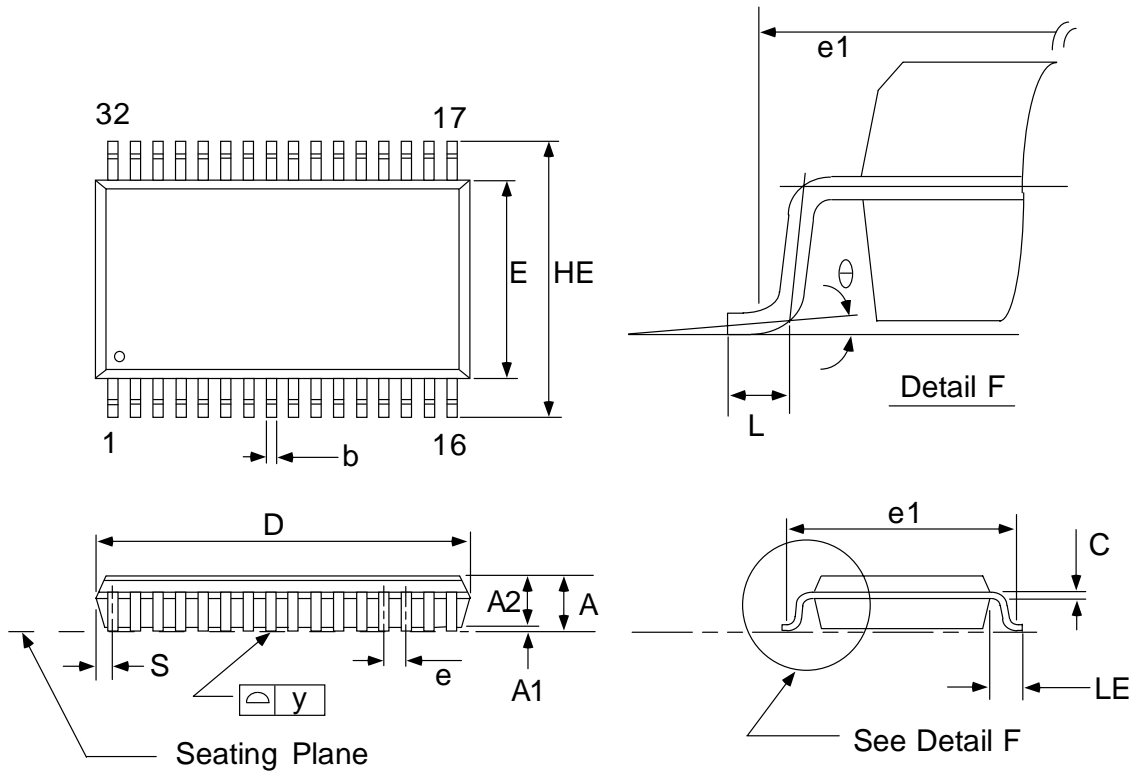

| Symbol | Dimension in inches | | | Dimension in mm | | |
|-----------|---------------------|-------|-------|-----------------|-------|-------|
| | min. | typ. | max | min. | typ. | max. |
| A | - | - | 0.118 | - | - | 3.00 |
| A1 | 0.004 | - | - | 0.10 | - | - |
| A2 | 0.101 | 0.106 | 0.111 | 2.57 | 2.69 | 2.82 |
| b | 0.014 | 0.016 | 0.020 | 0.36 | 0.41 | 0.51 |
| C | 0.006 | 0.008 | 0.012 | 0.15 | 0.20 | 0.31 |
| D | - | 0.805 | 0.817 | - | 20.45 | 20.75 |
| E | 0.440 | 0.445 | 0.450 | 11.18 | 11.30 | 11.43 |
| e | 0.044 | 0.050 | 0.056 | 1.12 | 1.27 | 1.42 |
| HE | 0.546 | 0.556 | 0.556 | 13.87 | 14.12 | 14.38 |
| L | 0.023 | 0.031 | 0.039 | 0.58 | 0.79 | 0.99 |
| LE | 0.047 | 0.055 | 0.063 | 1.19 | 1.40 | 1.60 |
| S | - | - | 0.036 | - | - | 0.91 |
| y | - | - | 0.004 | - | - | 0.10 |
| θ | 0° | - | 10° | 0° | - | 10° |

Notes :

1. Dimensions D max. & S include mold flash or tie bar burrs.
2. Dimension b does not include dambar protrusion / intrusion.
3. Dimensions D & E include mold mismatch and determined at the mold parting line.
4. controlling dimension : inches
5. general appearance spec should be based on final visual inspection spec.

PACKAGE DIMENSIONS
32-LEAD TSOP (8x20mm)

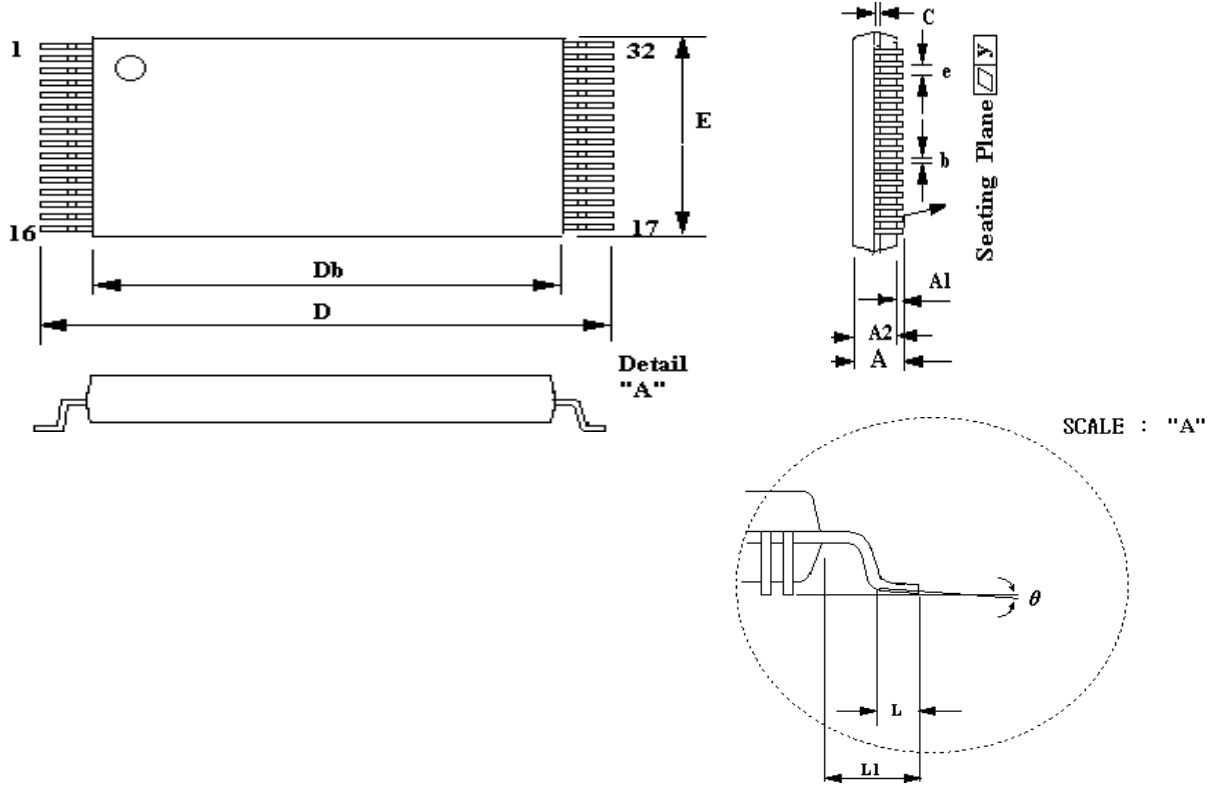

| SYMBOL | DIMENSIONS IN INCHES | | | DIMENSIONS IN MM | | |
|----------|----------------------|-------|-------|------------------|-------|-------|
| | MIN | NOM | MAX | MIN | NOM | MAX |
| A | -- | - | 0.047 | - | - | 1.20 |
| A1 | 0.002 | - | 0.006 | 0.05 | - | 0.15 |
| A2 | 0.035 | 0.040 | 0.041 | 0.90 | 1.00 | 1.05 |
| b | 0.007 | 0.008 | 0.011 | 0.17 | 0.20 | 0.27 |
| C | 0.004 | 0.006 | 0.008 | 0.10 | 0.15 | 0.21 |
| D | 0.787 TYP | | | 20.00 TYP | | |
| Db | 0.724 TYP | | | 18.40 TYP | | |
| E | 0.315 TYP | | | 8.00 TYP | | |
| L | 0.020 | 0.024 | 0.028 | 0.598 | 0.610 | 0.622 |
| L1 | 0.032 TYP | | | 0.813 TYP | | |
| θ | 0°~12° | | | 0°~12° | | |

PACKAGE DIMENSIONS
32-LEAD TSOP-I (8x13.4mm)

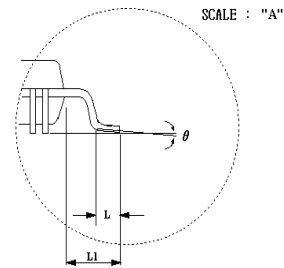
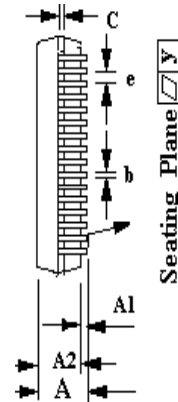
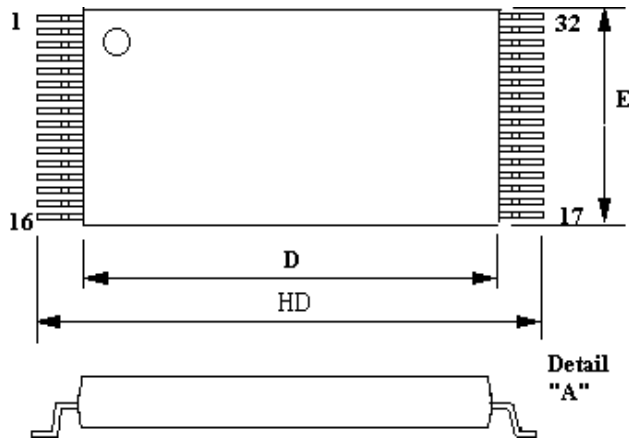

| SYMBOL | Dimension in inches | Dimension in mm |
|--------|---------------------|-----------------|
| A | 0.044(MAX) | 1.10(MAX) |
| A1 | 0.004±0.002 | 0.05±0.05 |
| A2 | 0.041(MAX) | 1.02(MAX) |
| b | 0.008±0.004 | 0.20±0.10 |
| C | 0.006±0.001 | 0.15±0.02 |
| D | 0.465±0.008 | 11.8±0.2 |
| E | 0.315±0.004 | 8.0±0.1 |
| HD | 0.528±0.008 | 13.4±0.2 |
| e | 0.020(TYP.) | 0.5(TYP.) |
| L | 0.020±0.004 | 0.5±0.1 |
| L1 | 0.031±0.008 | 0.8±0.2 |
| y | 0.002(MAX) | 0.05(MAX) |
| θ | 0° ~ 5° | 0° ~ 5° |

PACKAGE DIMENSIONS
32-LEAD DIP (600mil)

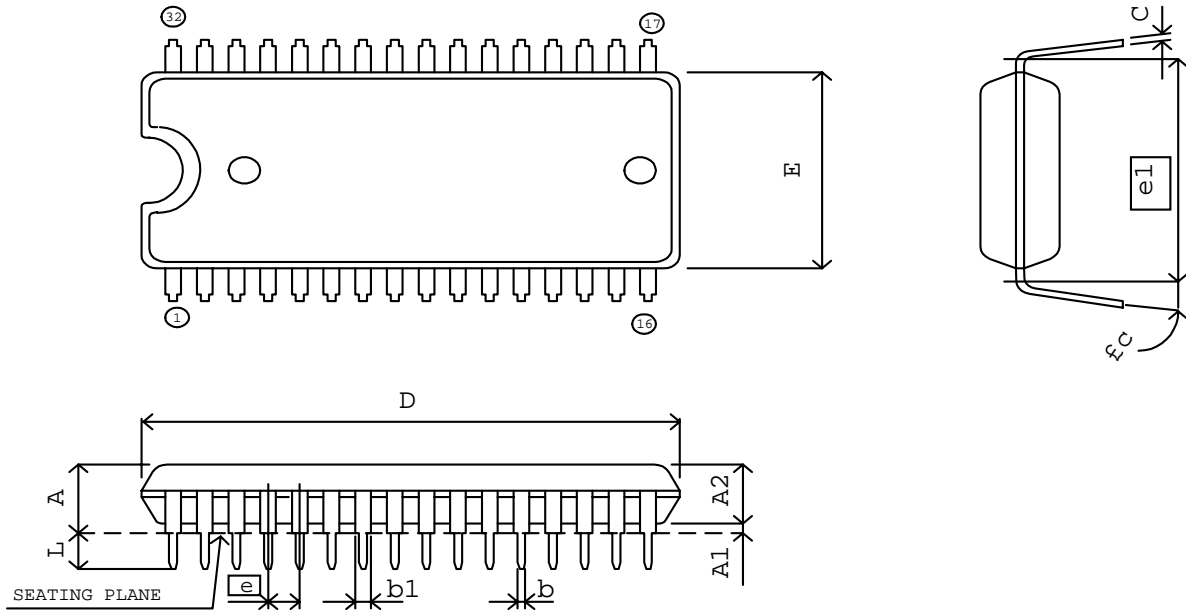

| Symbol | Dimension in inches | | | Dimension in mm | | |
|--------|---------------------|-------|-------|-----------------|-------|-------|
| | Min | Nom | Max | Min | Nom | Max |
| A | - | - | 0.200 | - | - | 5.08 |
| A1 | 0.015 | - | - | 0.38 | - | - |
| A2 | 0.142 | 0.150 | 0.158 | 3.61 | 3.81 | 4.01 |
| b | 0.014 | 0.018 | 0.022 | 0.36 | 0.46 | 0.56 |
| b1 | 0.056 | 0.060 | 0.064 | 1.42 | 1.52 | 1.62 |
| C | 0.008 | 0.010 | 0.014 | 0.20 | 0.25 | 0.35 |
| D | 1.642 | 1.650 | 1.658 | 41.71 | 41.91 | 42.11 |
| E | 0.527 | 0.535 | 0.543 | 13.40 | 13.60 | 13.80 |
| e | - | 0.100 | - | - | 2.54 | - |
| e1 | - | 0.600 | - | - | 15.24 | - |
| L | 0.118 | 0.130 | 0.142 | 3.00 | 3.30 | 3.60 |
| θ | 0 ~ 15° | | | | | |