

LCD MODULE SPECIFICATION

Products Name: APAX T15C1
38.1CM(15.0 INCH) XGA(1024x768)
262K COLOR TFT LCD MODULE
5.0V

- **Preliminary Specification**

This technical specification is tentative and it will be changed without notice.

進金生實業股份有限公司

台北市內湖區瑞光路76巷39號4樓

Tel:02-87912868 Fax:02-87912869

Version. 1.0

- CONTENTS -

REVISION HISTORY	-----	3
1. GENERAL DESCRIPTION	-----	4
1.1 OVERVIEW		
1.2 FEATURES		
1.3 APPLICATION		
1.4 GENERAL SPECIFICATIONS		
1.5 MECHANICAL SPECIFICATIONS		
2. ABSOLUTE MAXIMUM RATINGS	-----	5
2.1 ABSOLUTE RATINGS OF ENVIRONMENT		
2.2 ELECTRICAL ABSOLUTE RATINGS		
2.2.1 TFT LCD MODULE		
3. ELECTRICAL CHARACTERISTICS	-----	7
3.1 TFT LCD MODULE		
3.2 BACKLIGHT UNIT		
4. BLOCK DIAGRAM	-----	10
4.1 TFT LCD MODULE		
4.2 BACKLIGHT UNIT		
5. INPUT TERMINAL PIN ASSIGNMENT	-----	11
5.1 TFT LCD MODULE		
5.2 BACKLIGHT UNIT		
5.3 COLOR DATA INPUT ASSIGNMENT		
6. INTERFACE TIMING	-----	13
6.1 INPUT SIGNAL TIMING SPECIFICATIONS		
6.2 POWER ON/OFF SEQUENCE		
7. OPTICAL CHARACTERISTICS	-----	16
7.1 TEST CONDITIONS		
7.2 OPTICAL SPECIFICATIONS		
8. PRECAUTIONS	-----	19
8.1 HANDLING PRECAUTIONS		
8.2 STORAGE PRECAUTIONS		
8.3 OPERATION PRECAUTIONS		

REVISION HISTORY

Version	Date	Page (New)	Section	Description
Ver 3.0	Dec. 8' 00	All	All	Issue M150X1 approval spec.

1. GENERAL DESCRIPTION

1.1 OVERVIEW

M150X1 - 01 is a 15.0" TFT Liquid Crystal Display module with 4 CCFL Backlight units and 60 pins TTL interface. This module supports 1024 x 768 XGA mode and can display 262,144 colors. The optimum viewing angle is at 6 o' clock direction. The inverter module for Backlight is not built in.

1.2 FEATURES

- Wide viewing angle: 160 degrees both vertically and horizontally
- XGA (1024 x 768 pixels) resolution
- DE (Data Enable) only mode
- High contrast 400 : 1 Min.
- Fast Response : 25ms($T_R + T_F$)

1.3 APPLICATION

- Desktop LCD Monitors

1.4 GENERAL SPECIFICATIONS

Item	Specification	Unit	Note
Active Area	304.1(H) x 228.1(V) (15.0" diagonal)	mm	-
Driver Element	a-si TFT active matrix	-	-
Pixel Number	1024 x R.G.B. x 768	pixel	-
Pixel Pitch	0.297(H) x 0.297(W)	mm	-
Pixel Arrangement	RGB vertical stripe	-	-
Display Colors	262,144	color	-
Transmissive Mode	Normally black	-	-

1.5 MECHANICAL SPECIFICATIONS

Item	Min.	Typ.	Max.	Unit	Note
Module Size	Horizontal(H)	-	347.3	-	mm
	Vertical(V)	-	263.5	-	mm
	Depth(D)	-	16.5	-	mm
Weight	-	-	1,500	g	-

2. ABSOLUTE MAXIMUM RATINGS

2.1 ABSOLUTE RATINGS OF ENVIRONMENT

Item	Symbol	Value		Unit	Note
		Min.	Max.		
Storage Temperature	T _{ST}	-20	+60	°C	(1)
Operating Ambient Temperature	T _{OP}	0	+50	°C	(1), (2)
Storage Humidity	H _{ST}	5	85	%	-
Operation Humidity	H _{OP}	20	85	%	-
Shock (Non-Operating)	S _{NOP}	-	50	G	(3), (5)
Vibration (Non-Operating)	V _{NOP}	-	2	G	(4), (5)

Note (1) Temperature and relative humidity range is shown in the figure below.

- (a) 85 %RH Max. (Ta = 40 °C).
- (b) Wet-bulb temperature should be 39 °C Max. (Ta > 40 °C).
- (c) No condensation of water.

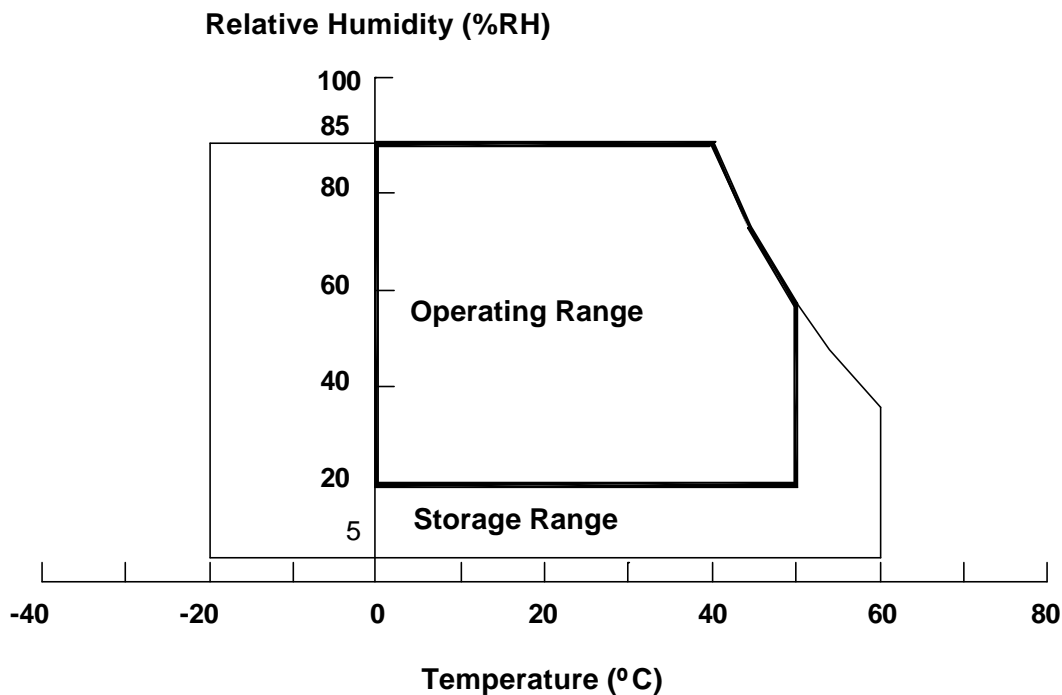

Note (2) The temperature of panel surface should be 0 °C Min. and 60 °C Max.

Note (3) 6ms, 1 time each ±X, ±Y and ±Z directions

Note (4) 10 ~ 500 Hz, 1 cycle/20min. 1.5mm max, 1 hour each X, Y and Z directions

Note (5) At testing Vibration and Shock, the fixture in holding the module has to be hard and rigid enough so that the module would not be twisted or bent by the fixture.

2.2 ELECTRICAL ABSOLUTE RATINGS

2.2.1 TFT LCD MODULE

Item	Symbol	Value		Unit	Note
		Min.	Max.		
Power Supply Voltage	V _{CC}	-0.3	6.0	V	(1)
Logic Input Voltage	V _{IN}	-0.3	V _{CC} + 0.3	V	

Note (1) Permanent damage to the device may occur if maximum values are exceeded. Function operation should be restricted to the conditions described under Normal Operating Conditions.

3. ELECTRICAL CHARACTERISTICS

3.1 TFT LCD MODULE

Parameter	Symbol	Value			Unit	Note	
		Min.	Typ.	Max.			
Power Supply Voltage	V_{CC}	4.5	5.0	5.5	V	-	
Ripple Voltage	V_{RP}	-	TBD		mV	-	
Rush Current	I_{RUSH}	-		4	A	(2)	
Power Supply Current	White	-	700	-	mA	(3)a	
	Black	-	480	-	mA	(3)b	
	Vertical Stripe	-	620	-	mA	(3)c	
Differential Input Voltage for TTL Receiver Threshold	"H" Level	V_{IH}	2.3	-	V_{CC}	V	-
	"L" Level	V_{IL}	V_{SS}	-	0.9	V	-
Terminating Resistor	R_T	-	100	-	Ohm	-	

Note (1) The module should be always operated within above ranges.

Note (2) Measurement Conditions:

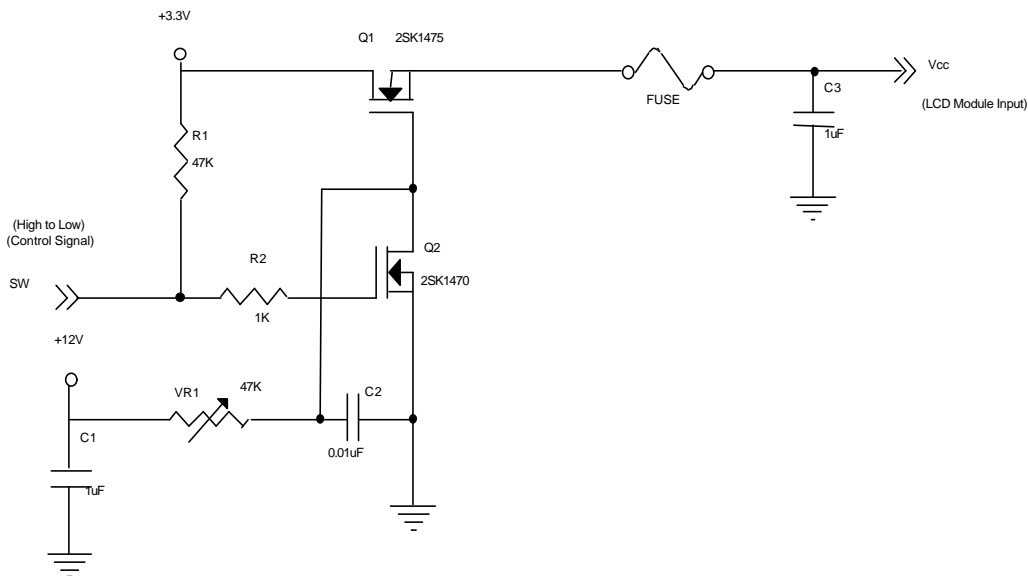

Vcc rising time is TBD

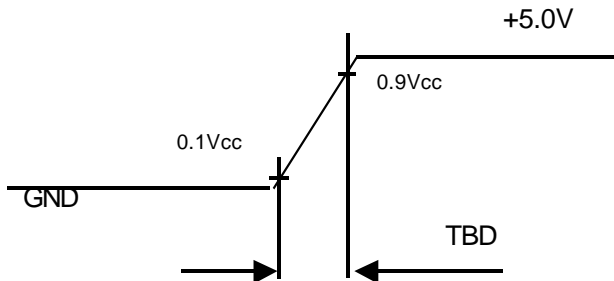

Note (3) The specified power supply current is under the conditions at $V_{CC} = 5.0V$, $T_a = 25 \pm 2 \text{ }^\circ\text{C}$, DC Current and $f_v = 60 \text{ Hz}$, whereas a power dissipation check pattern below is displayed.

a. White Pattern



Active Area

b. Black Pattern

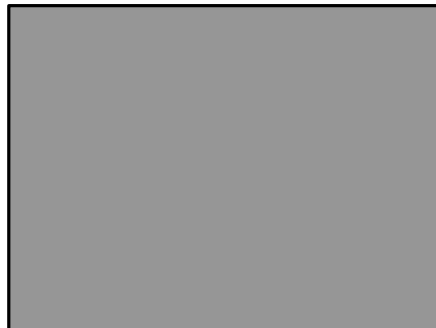

Active Area

c. Vertical Stripe Pattern

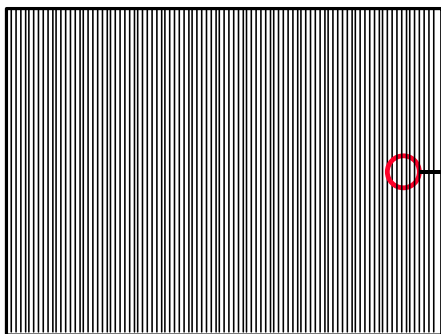

Active Area

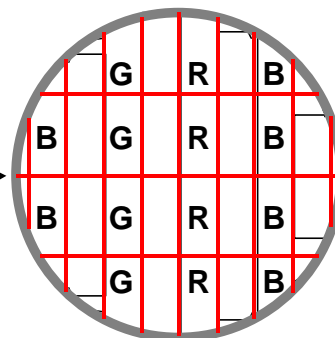

3.2 BACKLIGHT UNIT

Parameter	Symbol	Condition	Value			Unit	Note
			Min.	Typ.	Max.		
Lamp Input Voltage	V_L	$F_L=50\text{KHz}$, $I_L = 7\text{mA}$	550	580	610	V_{RMS}	-
Lamp Current	I_L	$F_L=50\text{KHz}$, $V_L=580 V_{RMS}$	6.0	7.0	8.0	mA_{RMS}	(1)
Lamp Turn On Voltage	V_S	$F_L=50\text{KHz}$, $T_a = 25 \text{ }^\circ\text{C}$	-	1324	1500	V_{RMS}	(2)
		$F_L=50\text{KHz}$, $T_a = 0 \text{ }^\circ\text{C}$	-	1324	1500	V_{RMS}	(2)
Operating Frequency	F_L	$V_L=580 V_{RMS}$	40	50	60	KHz	(3)
Lamp Life Time	L_{BL}	$I_L 7\text{mA}$	25,000		-	Hrs	(5)

Note (1) Lamp current is measured by utilizing a high frequency current meter as shown below:

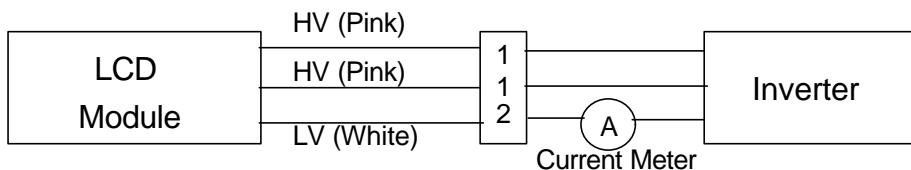

Note (2) The voltage shown above should be applied to the lamp for more than 1 second after startup. Otherwise the lamp may not be turned on.

Note (3) The lamp frequency may generate interference with horizontal synchronous frequency from the display, and this may cause line flow on the display. In order to avoid interference, the lamp frequency should be detached from the horizontal synchronous frequency and its harmonics as far as possible.

Note (4) $P_L = I_L \times V_L$

Note (5) The lifetime of lamp is defined as the time when it continues to operate under the conditions at $T_a = 25 \pm 2 \text{ }^\circ\text{C}$ and $I_L = 7.0\text{mA}_{\text{RMS}}$ until one of the following events occurs:

(a) When the brightness becomes 50% of its original value.

(b) When the effective ignition length becomes 80% of its original value. (Effective ignition length is defined as an area that the brightness is less than 70% compared to the center point.)

Note (6) The waveform of the voltage output of inverter must be area-symmetric and the design of the inverter must have specifications for the modularized lamp. The performance of the Backlight, such as lifetime or brightness, is greatly influenced by the characteristics of the DC-AC inverter for the lamp. All the parameters of an inverter should be carefully designed to avoid generating too much current leakage from high voltage output of the inverter. When designing or ordering the inverter please make sure that a poor lighting caused by the mismatch of the Backlight and the inverter (miss-lighting, flicker, etc.) never occurs. If the above situation is confirmed, the module should be operated in the same manners when it is installed in your instrument.

4. BLOCK DIAGRAM

4.1 TFT LCD MODULE

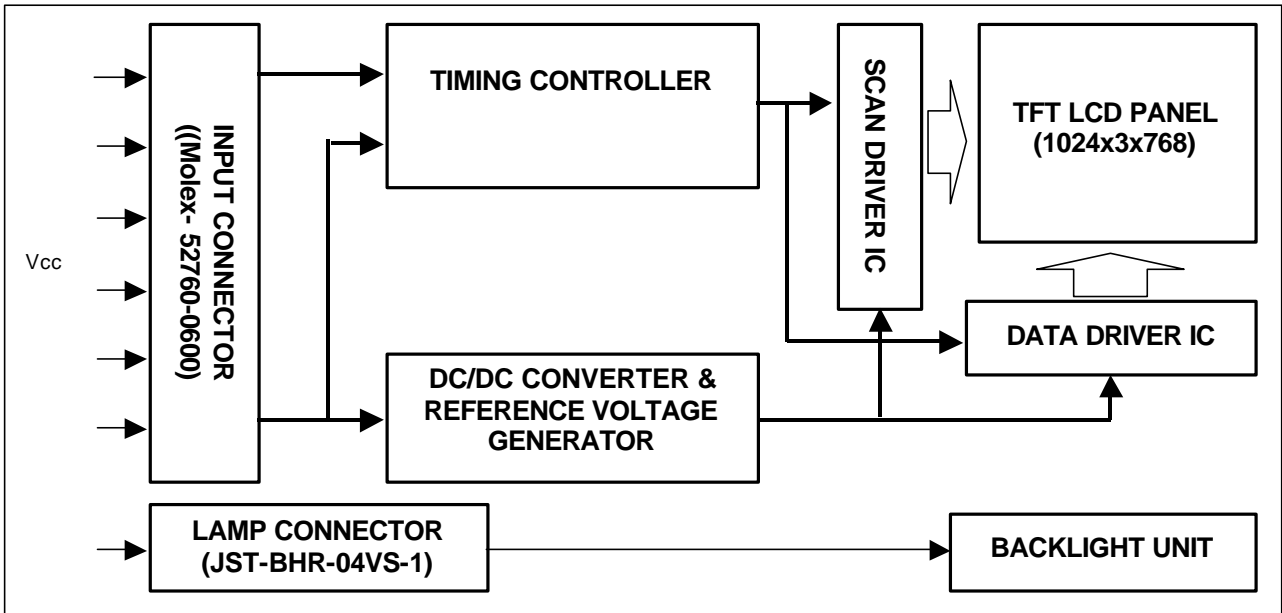

4.2 BACKLIGHT UNIT

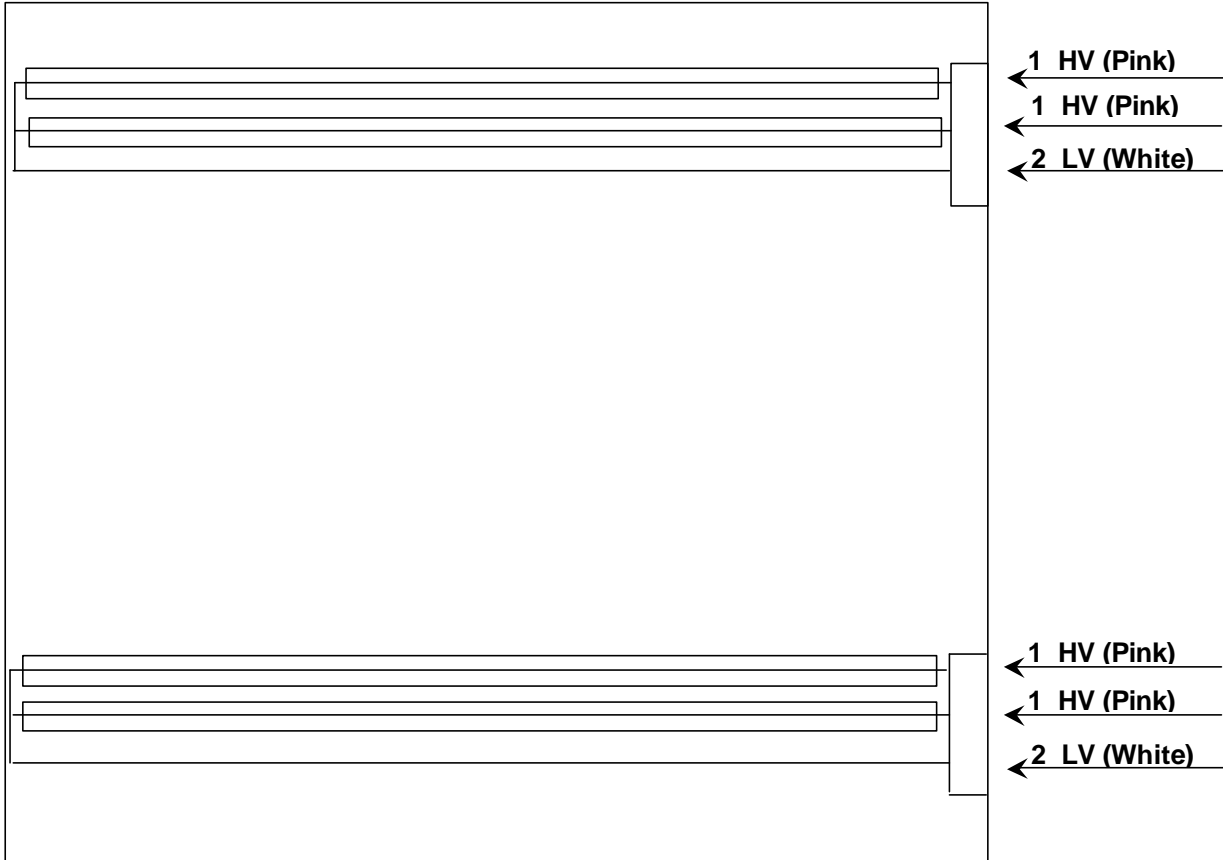

5. INPUT TERMINAL PIN ASSIGNMENT

5.1 TFT LCD MODULE

Pin No.	Symbol	I/O	Function	Pin No.	Symbol	I/O	Function
1	GND	----	Ground	31	GO1	I	Green odd data 1
2	RE0	I	Red even data 0	32	GO2	I	Green odd data 2
3	RE1	I	Red even data 1	33	GO3	I	Green odd data 3
4	RE2	I	Red even data 2	34	GO4	I	Green odd data 4
5	RE3	I	Red even data 3	35	GO5	I	Green odd data 5
6	RE4	I	Red even data 4	36	GND	----	Ground
7	RE5	I	Red even data 5	37	BO0	I	Blue odd data 0
8	GND	----	Ground	38	BO1	I	Blue odd data 1
9	GE0	I	Green even data 0	39	BO2	I	Blue odd data 2
10	GE1	I	Green even data 1	40	BO3	I	Blue odd data 3
11	GE2	I	Green even data 2	41	BO4	I	Blue odd data 4
12	GE3	I	Green even data 3	42	BO5	I	Blue odd data 5
13	GE4	I	Green even data 4	43	GND	----	Ground
14	GE5	I	Green even data 5	44	PULL	I	must be fixed to 0V
15	GND	----	Ground	45	PULL	I	must be fixed to 0V
16	BE0	I	Blue even data 0	46	ENAB	I	Data enable signal
17	BE1	I	Blue even data 1	47	GND	----	Ground
18	BE2	I	Blue even data 2	48	GND	----	Ground
19	BE3	I	Blue even data 3	49	DCLK	I	Dot clock signal
20	BE4	I	Blue even data 4	50	GND	----	Ground
21	BE5	I	Blue even data 5	51	GND	----	Ground
22	GND	----	Ground	52	S/S	----	S/S On/Off
23	RO0	I	Red odd data 0	53	NC	----	No contact
24	RO1	I	Red odd data 1	54	GND	----	Ground
25	RO2	I	Red odd data 2	55	GND	----	Ground
26	RO3	I	Red odd data 3	56	GND	----	Ground
27	RO4	I	Red odd data 4	57	Vcc	----	+5V Power supply
28	RO5	I	Red odd data 5	58	Vcc	----	+5V Power supply
29	GND	----	Ground	59	Vcc	----	+5V Power supply
30	GO0	I	Green odd data 0	60	Vcc	----	+5V Power supply

(1) Connector Part No.: 52760-0600(Molex)

(2) User' s connector Part No: 53475-600(Molex)

5.2 BACKLIGHT UNIT (for 2 lamp connectors)

Pin	Signal		Description	Color
1	HV1	HV3	High Voltage	Pink
2	HV2	HV4	High Voltage	Pink
3	NC	NC	-	-
4	LV(1,2)	LV(3,4)	Ground	White

Note (1) Connector Part No.: BHR-04VS-1 (JST) or equivalent

Note (2) User' s connector Part No.: SM04(4.0)B-BHS-1-TB (JST) or equivalent

Supplier : Japan Solderless Terminal Trading Company LTD.(JST)

5.3 COLOR DATA INPUT ASSIGNMENT

The brightness of each primary color (red, green and blue) is based on the 6-bit gray scale data input for the color. The higher the binary input the brighter the color. The table below provides the assignment of color versus data input.

		Data Signal																	
		Red						Green						Blue					
Color	Odd	RO5	RO4	RO3	RO2	RO1	RO0	GO5	GO4	GO3	GO2	GO1	GO0	BO5	BO4	BO3	BO2	BO1	BO0
	Even	RE5	RE4	RE3	RE2	RE1	RE0	GE5	GE4	GE3	GE2	GE1	GE0	BE5	BE4	BE3	BE2	BE1	BE0
Basic Colors	Black	0	0	0	0	0	0	0	0	0	0	0	0	0	0	0	0	0	0
	Red	1	1	1	1	1	1	0	0	0	0	0	0	0	0	0	0	0	0
	Green	0	0	0	0	0	0	1	1	1	1	1	1	0	0	0	0	0	0
	Blue	0	0	0	0	0	0	0	0	0	0	0	0	1	1	1	1	1	1
	Cyan	0	0	0	0	0	0	1	1	1	1	1	1	1	1	1	1	1	1
	Magenta	1	1	1	1	1	1	0	0	0	0	0	0	1	1	1	1	1	1
	Yellow	1	1	1	1	1	1	1	1	1	1	1	1	0	0	0	0	0	0
	White	1	1	1	1	1	1	1	1	1	1	1	1	1	1	1	1	1	1
Gray Scale Of Red	Red(0) / Dark	0	0	0	0	0	0	0	0	0	0	0	0	0	0	0	0	0	0
	Red(1)	0	0	0	0	0	1	0	0	0	0	0	0	0	0	0	0	0	0
	Red(2)	0	0	0	0	1	0	0	0	0	0	0	0	0	0	0	0	0	0
	⋮	⋮	⋮	⋮	⋮	⋮	⋮	⋮	⋮	⋮	⋮	⋮	⋮	⋮	⋮	⋮	⋮	⋮	⋮
	⋮	⋮	⋮	⋮	⋮	⋮	⋮	⋮	⋮	⋮	⋮	⋮	⋮	⋮	⋮	⋮	⋮	⋮	⋮
	Red(61)	1	1	1	1	0	1	0	0	0	0	0	0	0	0	0	0	0	0
	Red(62)	1	1	1	1	1	0	0	0	0	0	0	0	0	0	0	0	0	0
	Red(63)	1	1	1	1	1	1	0	0	0	0	0	0	0	0	0	0	0	0
Gray Scale Of Green	Green(0) / Dark	0	0	0	0	0	0	0	0	0	0	0	0	0	0	0	0	0	0
	Green(1)	0	0	0	0	0	0	0	0	0	0	0	1	0	0	0	0	0	0
	Green(2)	0	0	0	0	0	0	0	0	0	0	1	0	0	0	0	0	0	0
	⋮	⋮	⋮	⋮	⋮	⋮	⋮	⋮	⋮	⋮	⋮	⋮	⋮	⋮	⋮	⋮	⋮	⋮	⋮
	⋮	⋮	⋮	⋮	⋮	⋮	⋮	⋮	⋮	⋮	⋮	⋮	⋮	⋮	⋮	⋮	⋮	⋮	⋮
	Green(61)	0	0	0	0	0	0	1	1	1	1	0	1	0	0	0	0	0	0
	Green(62)	0	0	0	0	0	0	1	1	1	1	1	0	0	0	0	0	0	0
	Green(63)	0	0	0	0	0	0	1	1	1	1	1	1	0	0	0	0	0	0
Gray Scale Of Blue	Blue(0) / Dark	0	0	0	0	0	0	0	0	0	0	0	0	0	0	0	0	0	0
	Blue(1)	0	0	0	0	0	0	0	0	0	0	0	0	0	0	0	0	0	1
	Blue(2)	0	0	0	0	0	0	0	0	0	0	0	0	0	0	0	0	1	0
	⋮	⋮	⋮	⋮	⋮	⋮	⋮	⋮	⋮	⋮	⋮	⋮	⋮	⋮	⋮	⋮	⋮	⋮	⋮
	⋮	⋮	⋮	⋮	⋮	⋮	⋮	⋮	⋮	⋮	⋮	⋮	⋮	⋮	⋮	⋮	⋮	⋮	⋮
	Blue(61)	0	0	0	0	0	0	0	0	0	0	0	0	1	1	1	1	0	1
	Blue(62)	0	0	0	0	0	0	0	0	0	0	0	0	1	1	1	1	1	0
	Blue(63)	0	0	0	0	0	0	0	0	0	0	0	0	1	1	1	1	1	1

Note (1) 0: Low Level Voltage, 1: High Level Voltage

6. INTERFACE TIMING

6.1 INPUT SIGNAL TIMING SPECIFICATIONS

The input signal timing specifications are shown as the following table and timing diagram.

Item		Symbol	Min.	Typ.	Max.	Unit	Remark	
DCLK signal (Clock)	Period	Tc	25.000	30.764	40.000	ns	fc=1/Tc	
	Frequency	fc	25.000	32.505	40.000	MHz		
	Duty	Tch/Tc	40	50	60	%		
	High time	TclkH	5.0	-	-	ns		
	Low time	TclkL	5.0	-	-	ns		
	Rise time	Tclkr	-	-	5.0	ns		
	Fall time	Tclkf	-	-	5.0	ns		
DCLK-Data Timing	Setup time	Tset	4.5	-	-	ns	40MHz	
	Hold time	Thold	6.5	-	-	ns	40MHz	
ENAB signal	H	Period	Th	670	672	1566	clock	
		Frequency	fh	46.6	48.3	48.3	kHz	
		Display period	Thd	640	640	640	clock	
	V	Period	Tv	776	806	806	Th	
		Frequency	1/Tv	60	60	75	Hz	
		Display period	Tvd	768	768	768	Th	
	Data enable timing		Tdn	0	0	0	clock	

Note (1) Because this module is operated by DE only mode, Hsync and Vsync input signals should be set to low logic level or ground. Otherwise, this module would operate abnormally.

Note (2) The duration of DE signal must be longer than 1 clock period at every horizontal sync. period.

INPUT SIGNAL TIMING DIAGRAM

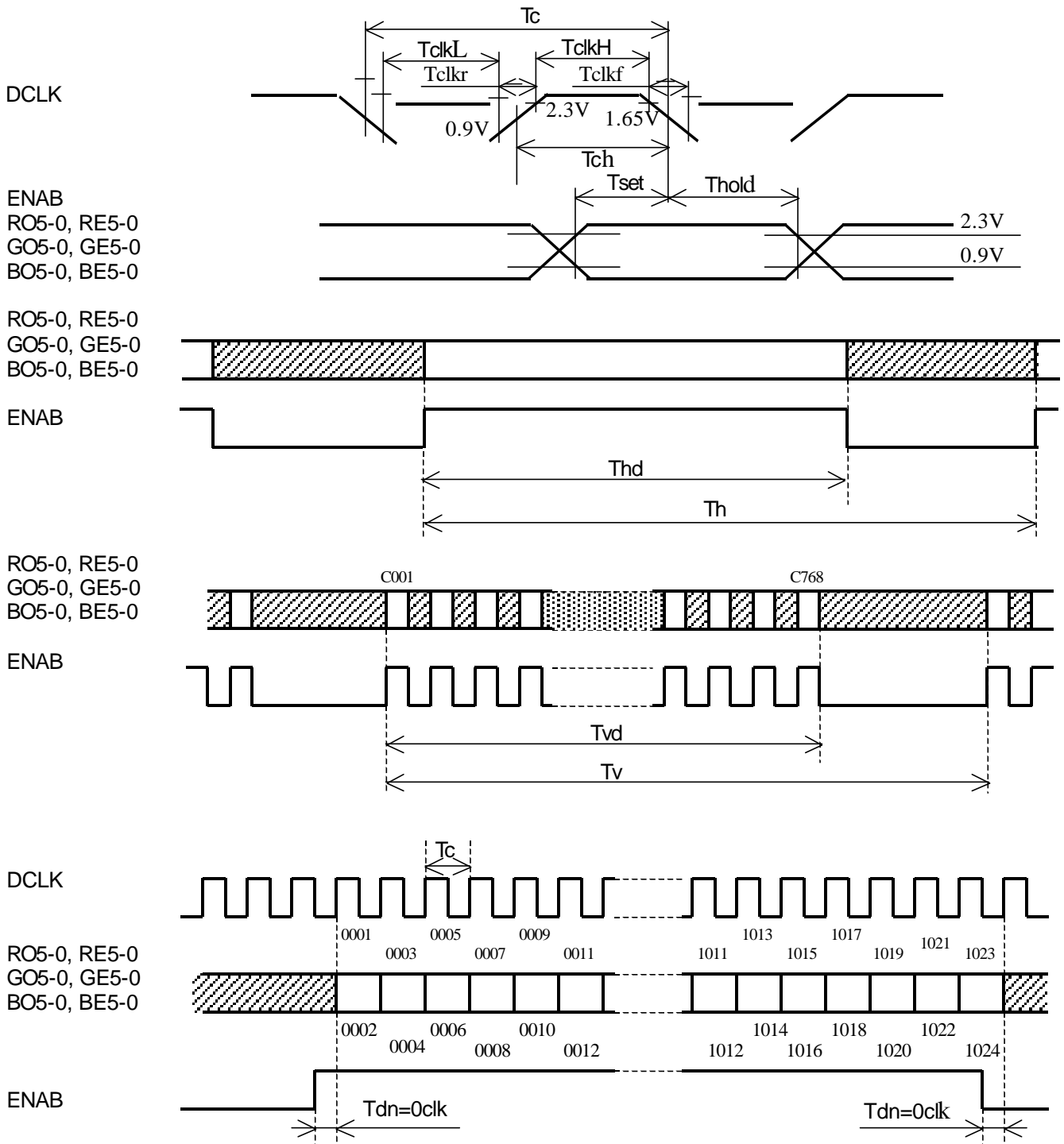

Correspondence between Data and Display Position

	S0001	S0002	S0003	S0004	S0005	S0006	S0007	S0008	-----	S3071	S3072
C001	RO	GO	BO	RE	GE	BE	RO	GO		GE	BE
	0001	0001	0001	0002	0002	0002	0003	0003		1024	1024
C768	RO	GO	BO	RE	GE	BE	RO	GO		GE	BE
	0001	0001	0001	0002	0002	0002	0003	0003		1024	1024

6.2 POWER ON/OFF SEQUENCE

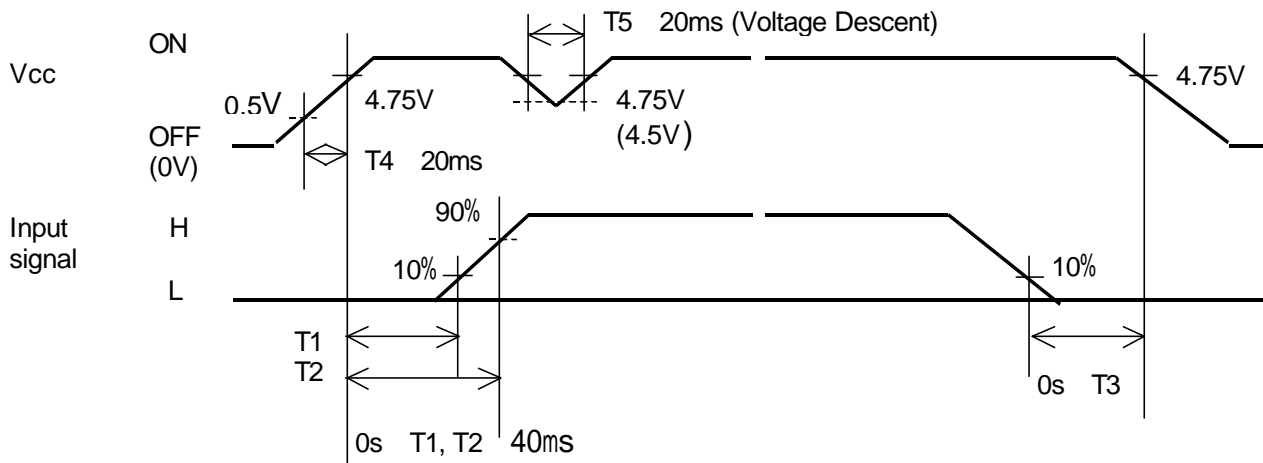

Note (1) Please avoid floating state of interface signal at invalid period.

Note (2) When the interface signal is invalid, be sure to pull down the power supply of LCD Vcc to 0 V.

Note (3) The Backlight inverter power must be turned on after the power supply for the logic and the interface signal is valid. The Backlight inverter power must be turned off before the power supply for the logic and the interface signal is invalid.

7. OPTICAL CHARACTERISTICS

7.1 TEST CONDITIONS

Item	Symbol	Value	Unit
Ambient Temperature	T _a	25±2	°C
Ambient Humidity	H _a	50±10	%RH
Supply Voltage	V _{CC}	5.0	V
Input Signal	According to typical value in "3. ELECTRICAL CHARACTERISTICS"		
Inverter Current	I _i	7.0	mA

The measurement methods of optical characteristics are shown in Section 7.2. The following items should be measured under the test conditions described in Section 7.1 and stable environment shown in Note (4).

7.2 OPTICAL SPECIFICATIONS

Item		Symbol	Condition	Min.	Typ.	Max.	Unit	Note
Contrast Ratio		CR	$\theta_x=0^\circ, \theta_y=0^\circ$ Viewing Normal Angle	300	400	-	-	(2), (4)
Response Time		T _R		-	15	30	ms	(3)
		T _F		-	10	25	ms	
Center Luminance of White		L		170	230	-	cd/m ²	(4)
Color Chromaticity	Red	R _x		0.596	0.616	0.636	-	(1), (4)
		R _y		0.324	0.344	0.364	-	
	Green	G _x		0.288	0.308	0.328	-	
		G _y		0.545	0.565	0.585	-	
	Blue	B _x		0.130	0.150	0.170	-	
		B _y		0.110	0.130	0.150	-	
	White	W _x	0.293	0.313	0.333	-		
		W _y	0.309	0.329	0.349	-		
Viewing Angle	Horizontal	θ_{x+}	CR≥10	80	-	-	Deg.	
		θ_{x-}		80	-	-		
	Vertical	θ_{y+}		80	-	-		
		θ_{y-}		80	-	-		

Note (1) Definition of Viewing Angle (θ_x , θ_y):

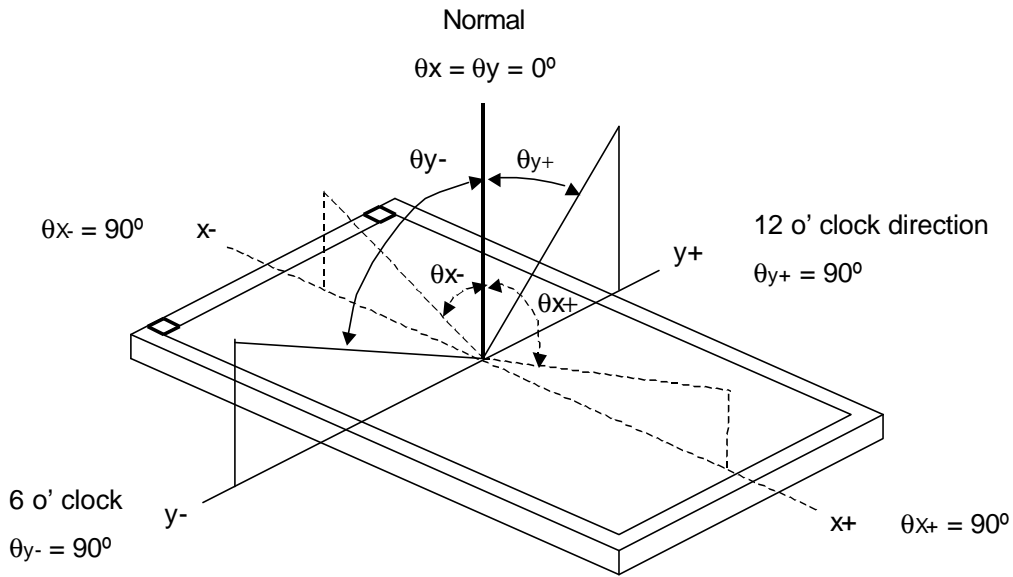

Note (2) Definition of Contrast Ratio (CR):

The contrast ratio can be calculated by the following expression.

$$\text{Contrast Ratio (CR)} = L_{63} / L_0$$

L63: Luminance of gray level 63

L 0: Luminance of gray level 0

$$\text{CR} = \text{CR} (5)$$

CR (X) is corresponding to the Contrast Ratio of the point X at Figure in Note (5).

Note (3) Definition of Response Time (T_R , T_F):

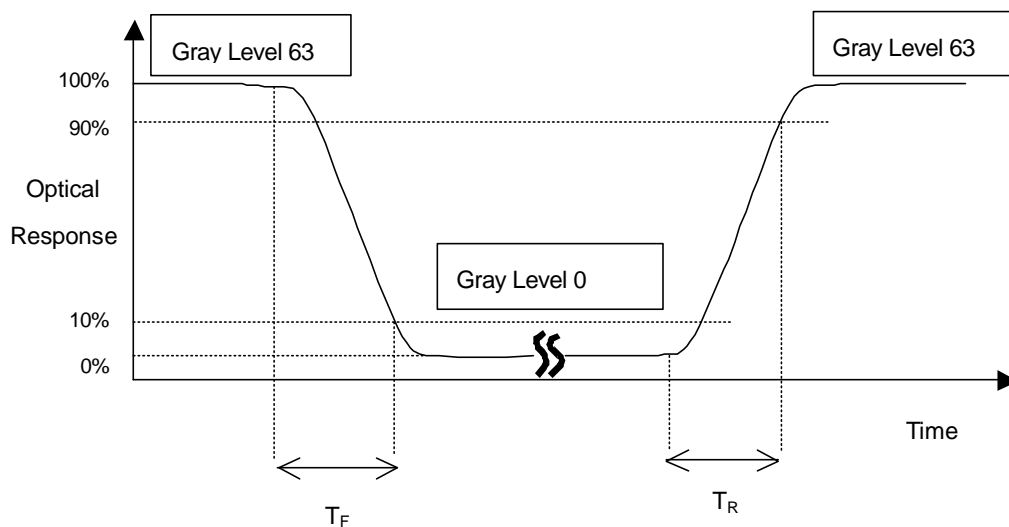

Note (4) Measurement Setup:

The LCD module should be stabilized at given temperature for 20 minutes to avoid abrupt temperature change during measuring. In order to stabilize the luminance, the measurement should be executed after lighting Backlight for 20 minutes in a windless room.

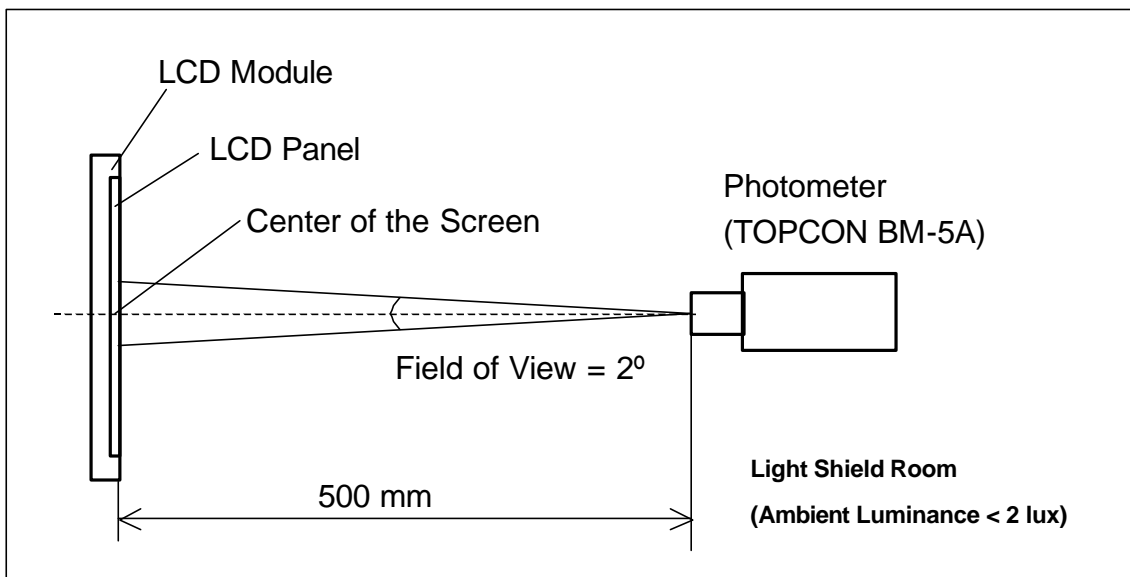

Note (5) Definition of luminance uniformity δW (5 points, gray level 255):

$$\delta W = \text{Maximum} [L(1), L(2), L(3), L(4), L(5)] / \text{Minimum} [L(1), L(2), L(3), L(4), L(5)]$$

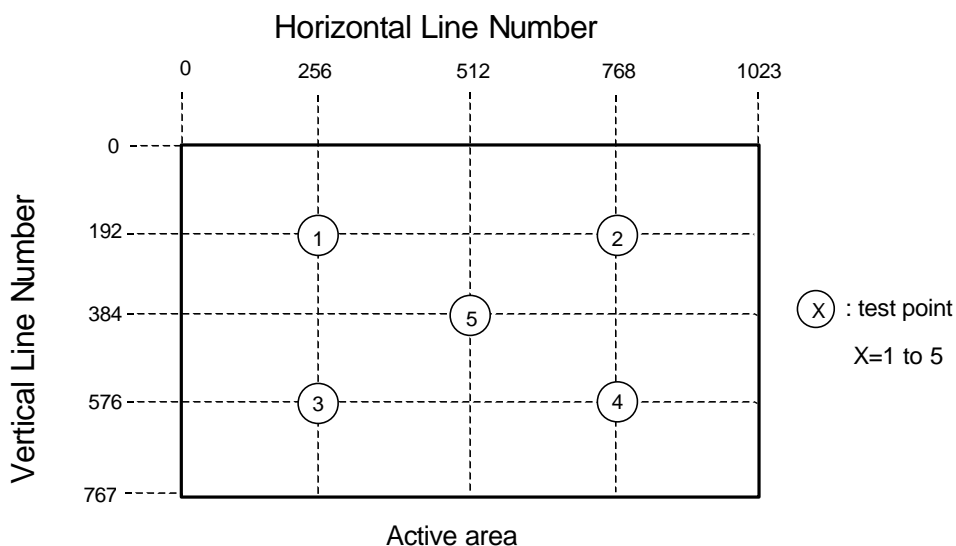

Horizontal Line Number [pixel]

8. PRECAUTIONS

8.1 HANDLING PRECAUTIONS

- (1) The module should be assembled into the system firmly by using every mounting hole. Be careful not to twist or bend the module.
- (2) While assembling or installing modules, it can only be in the clean area. The dust and oil may cause electrical short or damage the polarizer.
- (3) Use fingerstalls or soft gloves in order to keep display clean during the incoming inspection and assembly process.
- (4) Do not press or scratch the surface harder than a HB pencil lead on the panel because the polarizer is very soft and easily scratched.
- (5) If the surface of the polarizer is dirty, please clean it by some absorbent cotton or soft cloth. Do not use Ketone type materials (ex. Acetone), Ethyl alcohol, Toluene, Ethyl acid or Methyl chloride. It might permanently damage the polarizer due to chemical reaction.
- (6) Wipe off water droplets or oil immediately. Staining and discoloration may occur if they left on panel for a long time.
- (7) If the liquid crystal material leaks from the panel, it should be kept away from the eyes or mouth. In case of contacting with hands, legs or clothes, it must be washed away thoroughly with soap.
- (8) Protect the module from static electricity, it may cause damage to the C-MOS Gate Array IC.
- (9) Do not disassemble the module.
- (10) Do not pull or fold the lamp wire.
- (11) Pins of I/F connector should not be touched directly with bare hands.

8.2 STORAGE PRECAUTIONS

- (1) High temperature or humidity may reduce the performance of module. Please store LCD module within the specified storage conditions.
- (2) It is dangerous that moisture come into or contacted the LCD module, because the moisture may damage LCD module when it is operating.
- (3) It may reduce the display quality if the ambient temperature is lower than 10 °C. For example, the response time will become slowly, and the starting voltage of lamp will be higher than the room temperature.

8.3 OPERATION PRECAUTIONS

- (1) Do not pull the I/F connector in or out while the module is operating.
- (2) Always follow the correct power on/off sequence when LCD module is connecting and operating. This can prevent the CMOS LSI chips from damage during latch-up.
- (3) The startup voltage of Backlight is approximately 1000 Volts. It may cause electrical shock while assembling with inverter. Do not disassemble the module or insert anything into the Backlight unit.

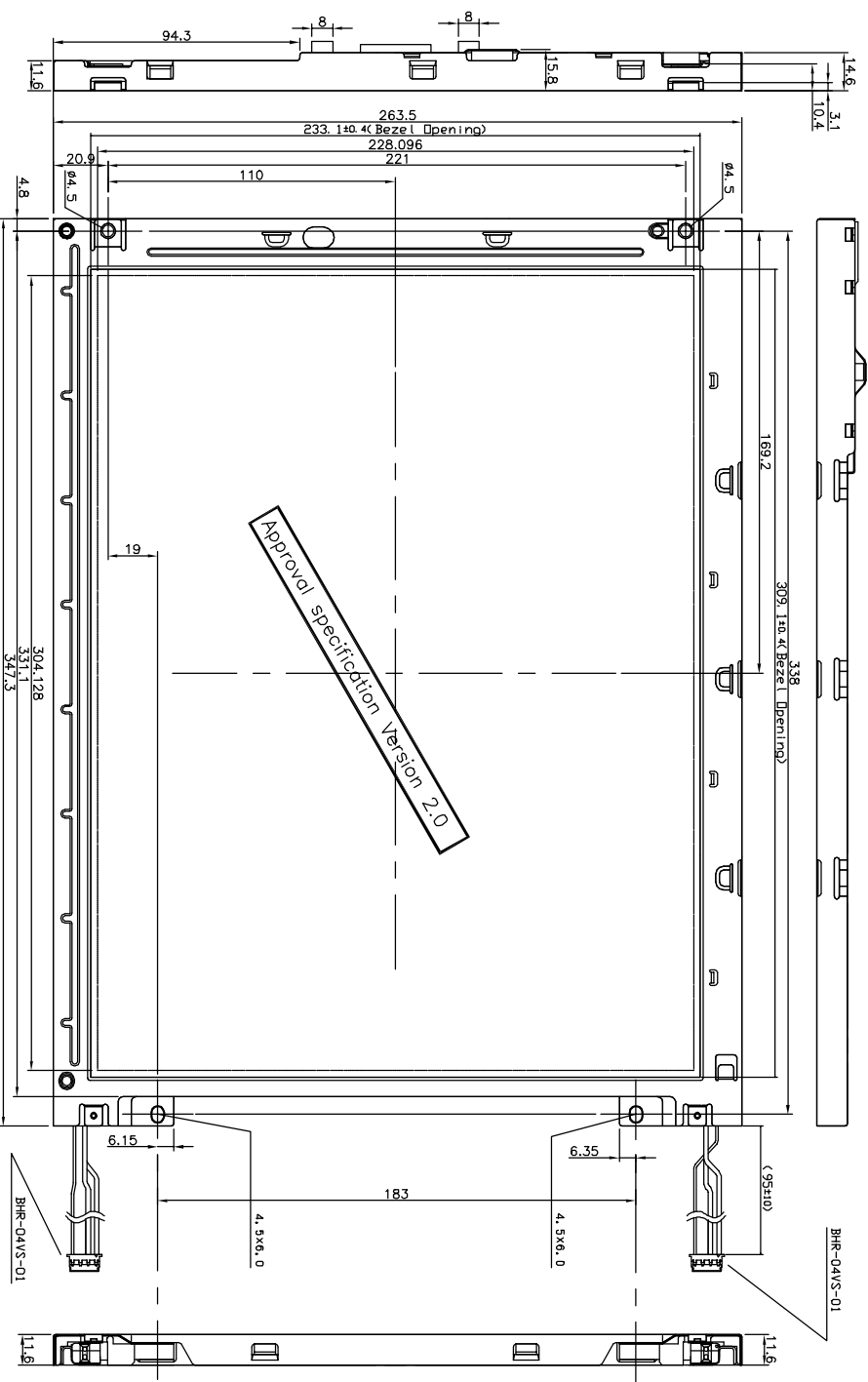

Front View

NOTES:
1. GENERAL TOLERANCE: ±0.5



APPROVED:	JACK FAN	DWG NO.:	F150141011	
CHECKED:	DAVID LIN	DATE:	12/08/2000	
DESIGNER:	DAVIS WANG	PART NO.:		
DRAWER:	DAVIS WANG	REV.:	1	UNIT:
TITLE:	Outline M150X1	SCALE:	1:2	SHEET:
			MM	1/2

"CHI MEI" COPYRIGHT 1998, ALL RIGHTS RESERVED, COPYING FORBIDDEN.

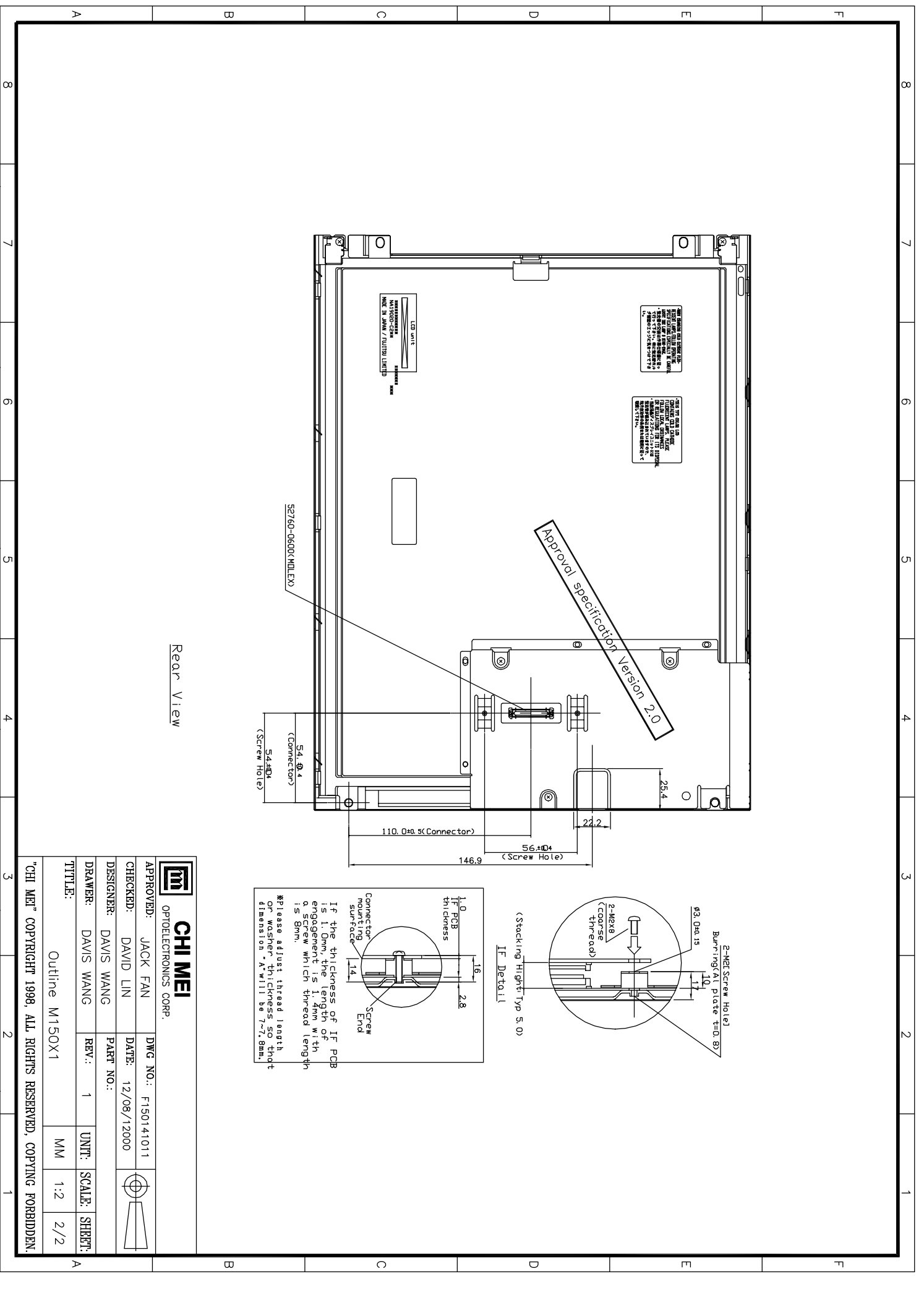

Rear View

1.0 If PCB thickness
 1.6
 2.8
 1.4
 Connecting mounting surface
 Screw End
 *If the thickness of IF PCB is 1.0mm, the length of engagement is 1.4mm with a screw which thread length is 8mm.
 *Please adjust thread length of master thickness SD chart dimension A will be 7.7.8mm.

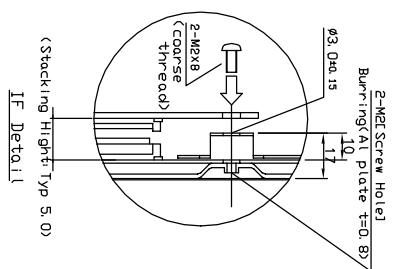

CHI MEI

OPTOELECTRONICS CORP.

APPROVED: JACK FAN DWG NO.: F150141011

CHECKED: DAVID LIN DATE: 12/08/12000

DESIGNER: DAVIS WANG PART NO.:

DRAWER: DAVIS WANG REV.: 1 UNIT: SCALE: SHEET:

TITLE: Outline M150X1 MM 1:2 2/2

"CHI MEI" COPYRIGHT 1998, ALL RIGHTS RESERVED, COPYING FORBIDDEN.