

# Coil Components (SMD)

## MC-200SC and MC-200SD Series

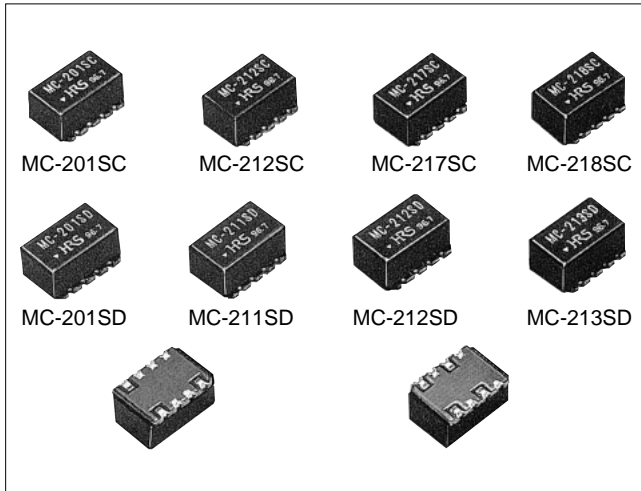

### ■ Features

#### 1. Excellent High Frequency Characteristics

Insertion loss: 0.6 dB TYP.  
Phase balance:  $\pm 3\text{deg}$  TYP.

#### 2. Highly Reliable Design

PPS resin is used for the exterior cladding of the cover, glass epoxy substrate is used for the board material, and solder plating is used for the electrodes. All these factors contribute to excellent mechanical strength, heat resistance, and soldering qualities

#### 3. Suited to Automatic Mounting

Embossed tape packaging permits automatic mounting. (Individual delivery can also be accommodated.)

### ■ Product Specifications

Ratings	Frequency range (Note) Characteristic impedance (Note) Maximum Input Power	30 to 370 MHz 50 ohms, 75 ohms 0.5 W	Operating temperature range Operating relative humidity	-10°C to +65°C 95% Max.
---------	--	--	--	----------------------------

Note: The frequency range and the characteristic impedance will differ depending on the products.

Item	Standard	Conditions
1. Vibration	No damage, cracks, or parts dislocation	Frequency of 10 to 2000 Hz, overall amplitude of 1.52 mm, acceleration of 98 m/s <sup>2</sup> for 4 hours in each of 3 directions
2. Shock		Acceleration of 294 m/s <sup>2</sup> , sine half-wave waveform, 3 cycles in each of the 3 axis
3. Temperature cycle		(-60 to 55°C: 30 min. → 20 to 35°C: 15 min. → 125 to 128°C: 30 min. → 20 to 35°C: 15 min.) for 100 cycles
4. Corrosion resistance	No serious corrosion	Exposed to 5% salt water solution for 48 hours

● The test method conforms to MIL-STD-202.

### ■ Materials

Part	Material	Finish
Board	Glass epoxy	Solder plating
Cover	PPS	-----

### ■ External Dimensions

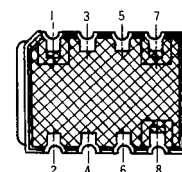
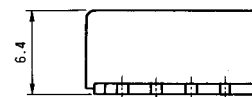
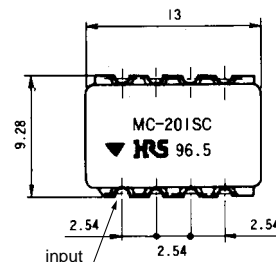

● The contact numbers are common for both the 0° type and the 90° type.

### ■ Ordering Information

**MC - 2 0 1 S C**  
① ② ③ ④ ⑤ ⑥

① Series Name: MC	④ Suffix
② Number of Divisions Indicated by number of divisions of output.	⑤ Board Mounting Method S : SMT type
③ Phase Difference Indicated by phase difference of output. 0 : 0° 1 : 90°	⑥ Characteristic Impedance C : 75 ohms D : 50 ohms

## Specifications

Part Number	Frequency Range (MHZ)	Phase Difference (deg)	※ above 3dB Insertion Loss (dB Max)	Isolation (dB Min)	V.S.W.R. (Max)	Balance		Impedance (ohms)	Weight (g)
						Phase (deg)	Amplitude (dB)		
MC-201SC	30~200	0	0.6	20	1.3	±3	±0.1	75	1
MC-212SC	50~ 95	- 90	0.6	20	1.2	±3	±0.5	75	1
MC-217SC	45~ 70	- 90	0.6	20	1.2	±3	±0.5	75	1
MC-218SC	70~100	- 90	0.6	20	1.2	±3	±0.5	75	1
MC-201SD	30~230	0	0.6	20	1.3	±3	±0.15	50	1
MC-211SD	170~230	- 90	0.6	20	1.2	±3	±0.5	50	1
MC-212SD	45~104	- 90	0.6	20	1.2	±3	±0.5	50	1
MC-213SD	330~370	- 90	1.3	16	1.4	±4	±0.5	50	1

Note 1: The insertion loss of the 2-way 90° type is the average output of the 0° port and the -90° port minus 3 dB coupling.

Note 2: When ordering items with embossed tape packaging, affix (06) to the end of the product number. One reel contains 500 pieces.

## Function Diagram

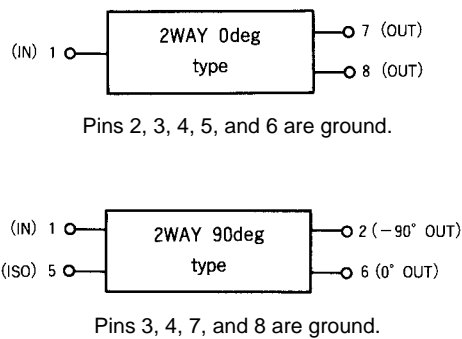

## PCB Mounting Pattern

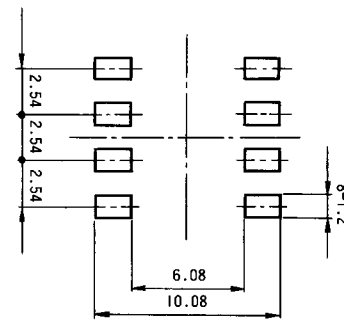

● Please apply resist processing to the area around the electrode pads.

## Precautions

1.Soldering (1)Recommended temperature profile	<p>Note 1: Up to 2 cycles of reflow soldering are possible under the same conditions, provided that there is a return to normal temperature between the first and second cycle.</p> <p>Note 2: The temperature profile indicates the board surface temperature at the point of contacts with the connector terminals (for surface mounted receptacle).</p>
(2)Recommended manual soldering	Manual soldering: 260°C for 10 seconds
(3)Recommended screen thickness	0.15 mm
2.Product Storage	①After opening the package reseal promptly or store in a desiccator with a desiccant. ②Store in a place that is not exposed to harmful gases which include sulfur or chlorine, etc. ③Use within one year of delivery.

# Typical Data

