



MICROCHIP PIC16F193X/16LF193X

28/40/44-Pin 8-Bit Flash Microcontroller Product Brief

High-Performance RISC CPU:

- Only 49 Instructions to Learn
- Operating Speed:
 - DC – 32 MHz clock input
 - DC – 125 ns instruction cycle
- Interrupt Capability with Automatic Context Saving
- 16-Level Deep Hardware Stack with Optional Overflow/Underflow Reset
- Direct, Indirect and Relative Addressing modes:
 - Two full 16-bit File Select Registers (FSRs)
 - FSRs can read program and data memory

Special Microcontroller Features:

- Precision Internal Oscillator:
 - Factory calibrated to $\pm 1\%$, typical
 - Software selectable frequency range from 32 MHz to 31 kHz
- 31 kHz Low-Power Internal Oscillator
- External Oscillator Block with:
 - 4 crystal/resonator modes up to 32 MHz using 4xPLL
 - 3 external clock modes up to 32 MHz
- 4x Phase Locked Loop (PLL)
- Fail-Safe Clock Monitor
- Two-Speed Start-up
- Power-Saving Sleep mode
- Power-on Reset (POR)
- Power-up Timer (PWRT)
- Oscillator Start-up Timer (OST)
- Brown-out Reset (BOR) with Selectable Trip Point
- Extended Watch-Dog Timer (WDT)
- In-Circuit Serial Programming™ (ICSP™) via two pins
- In-Circuit Debug (ICD) via Two Pins
- Enhanced Low-Voltage Programming (LVP)
- Operating Voltage Range:
 - 1.8V to 3.6V (PIC16LF193X)
 - 1.8V to 5.5V (PIC16F193X)
- Programmable Code Protection
- Self-Programmable under Software Control

Low-Power Features:

- Standby Current (PIC16LF193X):
 - 100 nA @ 1.8V, typical
- Operating Current (PIC16LF193X):
 - 150 μ A @ 1 MHz, 1.8V, typical
- Low-Power Watchdog Timer Current (PIC16LF193X):
 - 1.0 μ A @ 1.8V, typical

Peripheral Features:

- Integrated LCD Controller:
 - Up to 96 segments
 - Variable clock input
 - Contrast control
 - Internal voltage reference selections
- Up to 35 I/O Pins and 1 Input-only Pin:
 - High current sink/source for LED drivers
 - Individually programmable interrupt-on-change pins
 - Individually programmable weak pull-ups
- Timer0: 8-Bit Timer/Counter with 8-Bit Programmable Prescaler
- Enhanced Timer1:
 - 16-bit timer/counter with prescaler
 - External Gate Input mode
 - Dedicated low-power 32 kHz oscillator driver
- Timer2, 4, 6: 8-Bit Timer/Counter with 8-Bit Period Register, Prescaler and Postscaler
- Two Capture/Compare/PWM modules (CCP):
 - Software selectable time bases
- Three Enhanced Capture, Compare, PWM modules (ECCP):
 - Software selectable time bases
 - Auto-shutdown and auto-restart
 - PWM steering
- Master Synchronous Serial Port (SSP) with SPI and I²C™ with:
 - 7-bit address masking
 - SMBus/PMBus™ compatibility
- Enhanced Universal Synchronous Asynchronous Receiver Transmitter (EUSART):
 - RS-232, RS-485 and LIN compatible
 - Auto-Baud Detect
 - Auto-wake-up on start
- SR Latch (Integrated 555 Timer):
 - Multiple Set/Reset input options
- Analog-to-Digital Converter (ADC):
 - 10-bit resolution
 - Up to 14 channels
- 2 Comparators:
 - Rail-to-rail inputs
 - Power mode control
 - Software controllable hysteresis
- Voltage Reference module:
 - Fixed Voltage Reference (FVR) with 1.024V, 2.048V and 4.096V output levels
 - 5-bit rail-to-rail resistive DAC with positive and negative reference selection
- mTouch™ Sensing oscillator module
 - Up to 16 channels for button, sensor or slider input

PIC16F193X/16LF193X

TABLE 1: PIC16F193X/16LF193X FAMILY TYPES

Device	Program Memory Flash (words)	Data EEPROM (bytes)	SRAM (bytes)	I/Os	10-bit A/D (ch)	Timers 8/16-bit	EUSART	I ² C™ and SPI	CCP/ECCP	LCD segments/commons
PIC16F1933	4096	256	256	25	11	4/1	Yes	Yes	2/3	16 ⁽¹⁾ /4
PIC16LF1933	4096	256	256	25	11	4/1	Yes	Yes	2/3	16 ⁽¹⁾ /4
PIC16F1934	4096	256	256	36	14	4/1	Yes	Yes	2/3	24/4
PIC16LF1934	4096	256	256	36	14	4/1	Yes	Yes	2/3	24/4
PIC16F1936	8192	256	512	25	11	4/1	Yes	Yes	2/3	16 ⁽¹⁾ /4
PIC16LF1936	8192	256	512	25	11	4/1	Yes	Yes	2/3	16 ⁽¹⁾ /4
PIC16F1937	8192	256	512	36	14	4/1	Yes	Yes	2/3	24/4
PIC16LF1937	8192	256	512	36	14	4/1	Yes	Yes	2/3	24/4
PIC16F1938	16384	256	1024	25	11	4/1	Yes	Yes	2/3	16 ⁽¹⁾ /4
PIC16LF1938	16384	256	1024	25	11	4/1	Yes	Yes	2/3	16 ⁽¹⁾ /4
PIC16F1939	16384	256	1024	36	14	4/1	Yes	Yes	2/3	24/4
PIC16LF1939	16384	256	1024	36	14	4/1	Yes	Yes	2/3	24/4

Note 1: COM3 and SEG15 share the same physical pin on the PIC16F1933/1936/1938, therefore SEG15 is not available when using 1/4 multiplex displays.

FIGURE 1: 28-PIN SPDIP, SOIC, SSOP PACKAGE DIAGRAM FOR PIC16F1933/1936/1938 AND PIC16LF1933/1936/1938

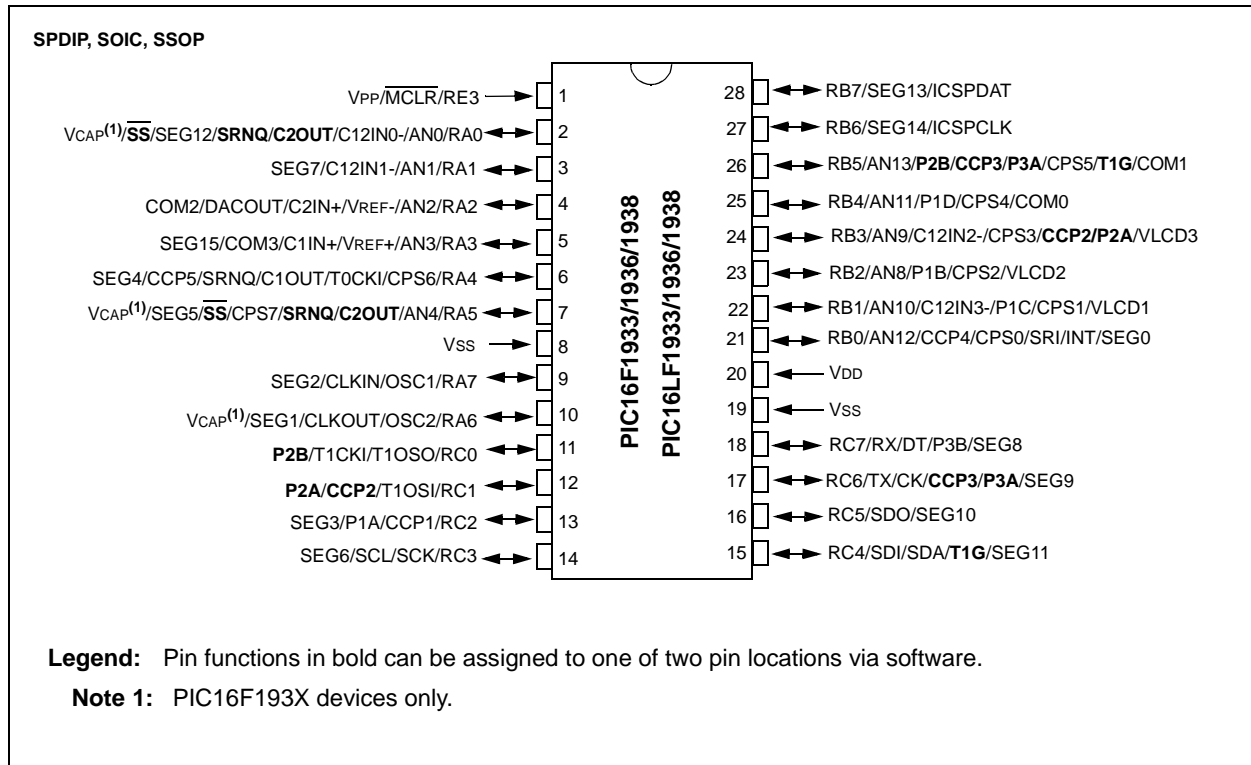

PIC16F193X/16LF193X

FIGURE 2: 28-PIN QFN PACKAGE DIAGRAM FOR PIC16F1933/1936/1938 AND PIC16LF1933/1936/1938

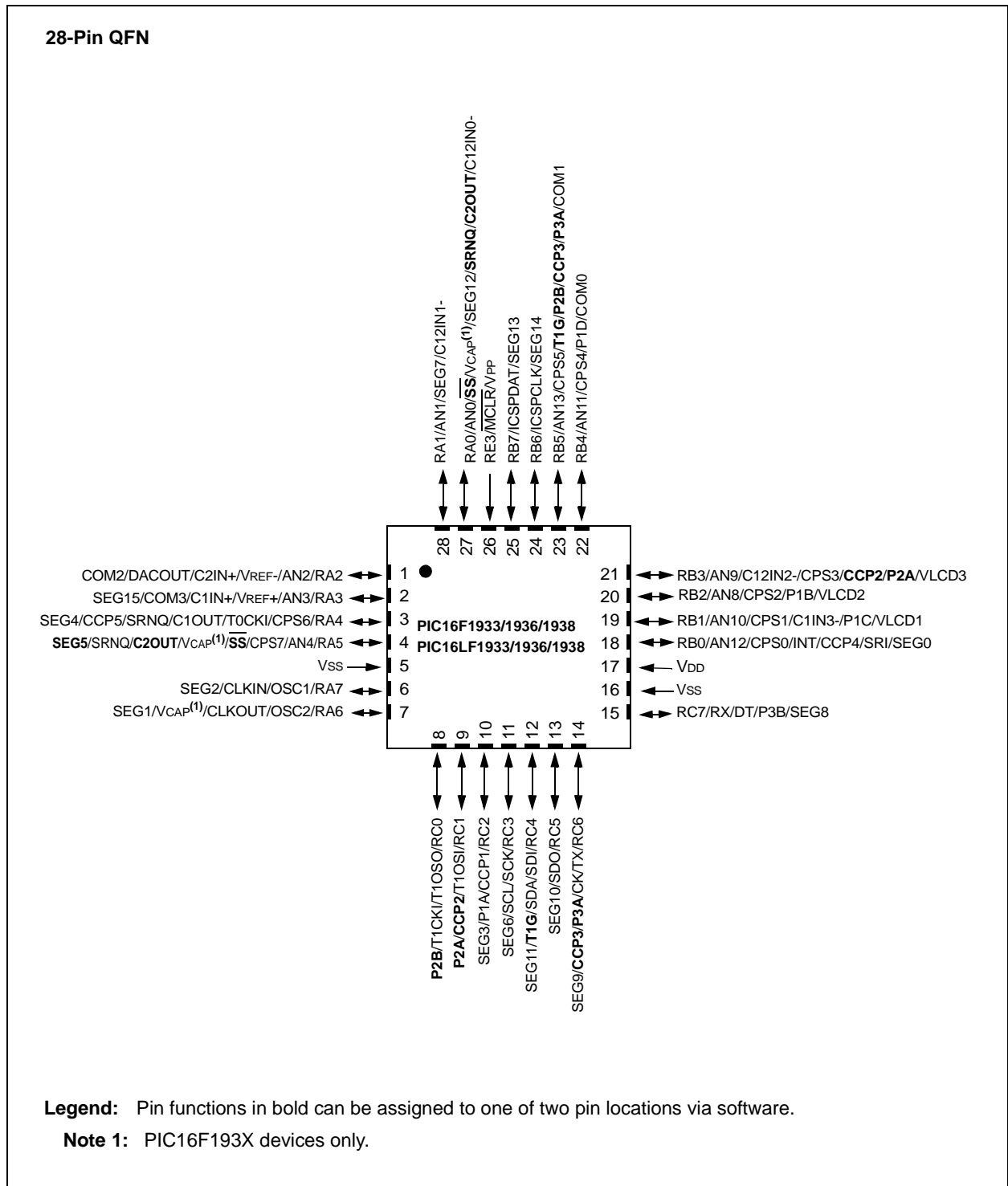

PIC16F193X/16LF193X

www.DataSheet4U.com

TABLE 2: 28-PIN ALLOCATION TABLE (PIC16F193X)

I/O	28-Pin SPDIP, SOIC, SSOP	28-Pin QFN	A/D	Cap Sense	Comparator	SR Latch	Timers	CCP	EUSART	MSSP	LCD	Interrupt	Pull-up	Basic
RA0	2	27	AN0	—	C12IN0-/C2OUT ⁽¹⁾	SRNQ ⁽¹⁾	—	—	—	SS ⁽¹⁾	SEG12	—	—	VCAP
RA1	3	28	AN1	—	C12IN1-	—	—	—	—	—	SEG7	—	—	—
RA2	4	1	AN2/VREF-	—	C2IN+/DACOUT	—	—	—	—	—	COM2	—	—	—
RA3	5	2	AN3/VREF+	—	C1IN+	—	—	—	—	—	SEG15/COM3	—	—	—
RA4	6	3	—	CPS6	C1OUT	SRNQ	T0CKI	CCP5	—	—	SEG4	—	—	—
RA5	7	4	AN4	CPS7	C2OUT ⁽¹⁾	SRNQ ⁽¹⁾	—	—	—	SS ⁽¹⁾	SEG5	—	—	VCAP
RA6	10	7	—	—	—	—	—	—	—	—	SEG1	—	—	OSC2/CLKOUT VCAP
RA7	9	6	—	—	—	—	—	—	—	—	SEG2	—	—	OSC1/CLKIN
RB0	21	18	AN12	CPS0	—	SRI	—	CCP4	—	—	SEG0	INT/IO	Y	—
RB1	22	19	AN10	CPS1	C12IN3-	—	—	P1C	—	—	VLCD1	IO	Y	—
RB2	23	20	AN8	CPS2	—	—	—	P1B	—	—	VLCD2	IO	Y	—
RB3	24	21	AN9	CPS3	C12IN2-	—	—	CCP2 ⁽¹⁾ / P2A ⁽¹⁾	—	—	VLCD3	IO	Y	—
RB4	25	22	AN11	CPS4	—	—	—	P1D	—	—	COM0	IO	Y	—
RB5	26	23	AN13	CPS5	—	—	T1G ⁽¹⁾	P2B ⁽¹⁾ / CCP3 ⁽¹⁾ / P3A ⁽¹⁾	—	—	COM1	IO	Y	—
RB6	27	24	—	—	—	—	—	—	—	—	SEG14	IO	Y	ICSPCLK
RB7	28	25	—	—	—	—	—	—	—	—	SEG13	IO	Y	ICSPDAT
RC0	11	8	—	—	—	—	T1OSO/ T1CKI	P2B ⁽¹⁾	—	—	—	—	—	—
RC1	12	9	—	—	—	—	T1OSI	CCP2 ⁽¹⁾ / P2A ⁽¹⁾	—	—	—	—	—	—
RC2	13	10	—	—	—	—	—	CCP1/ P1A	—	—	SEG3	—	—	—
RC3	14	11	—	—	—	—	—	—	—	SCK/SCL	SEG6	—	—	—
RC4	15	12	—	—	—	—	T1G ⁽¹⁾	—	—	SDI/SDA	SEG11	—	—	—
RC5	16	13	—	—	—	—	—	—	—	SDO	SEG10	—	—	—
RC6	17	14	—	—	—	—	—	CCP3 ⁽¹⁾ / P3A ⁽¹⁾	TX/CK	—	SEG9	—	—	—
RC7	18	15	—	—	—	—	—	P3B	RX/DT	—	SEG8	—	—	—
RE3	1	26	—	—	—	—	—	—	—	—	—	—	Y	MCLR/VPP
VDD	20	17	—	—	—	—	—	—	—	—	—	—	—	VDD
VSS	8, 19	5, 16	—	—	—	—	—	—	—	—	—	—	—	VSS

Note 1: Pin functions can be assigned to one of two pin locations via software.

PIC16F193X/16LF193X

FIGURE 3: 40-PIN PDIP PACKAGE DIAGRAM FOR PIC16F1934/1937/1939 AND PIC16LF1934/1937/1939

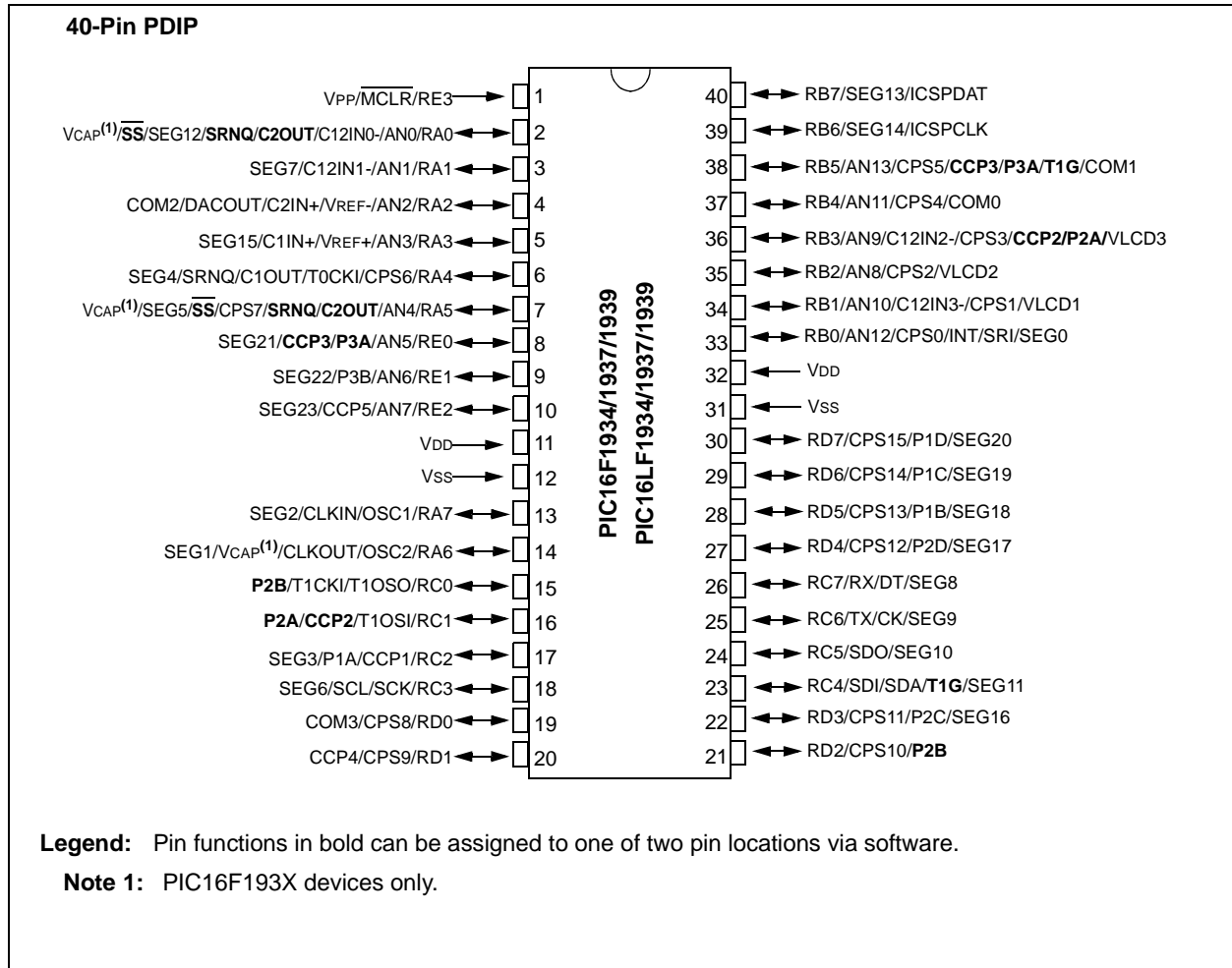

PIC16F193X/16LF193X

FIGURE 4: 44-PIN QFN PACKAGE DIAGRAM FOR PIC16F1934/1937/1939 AND PIC16LF1934/1937/1939

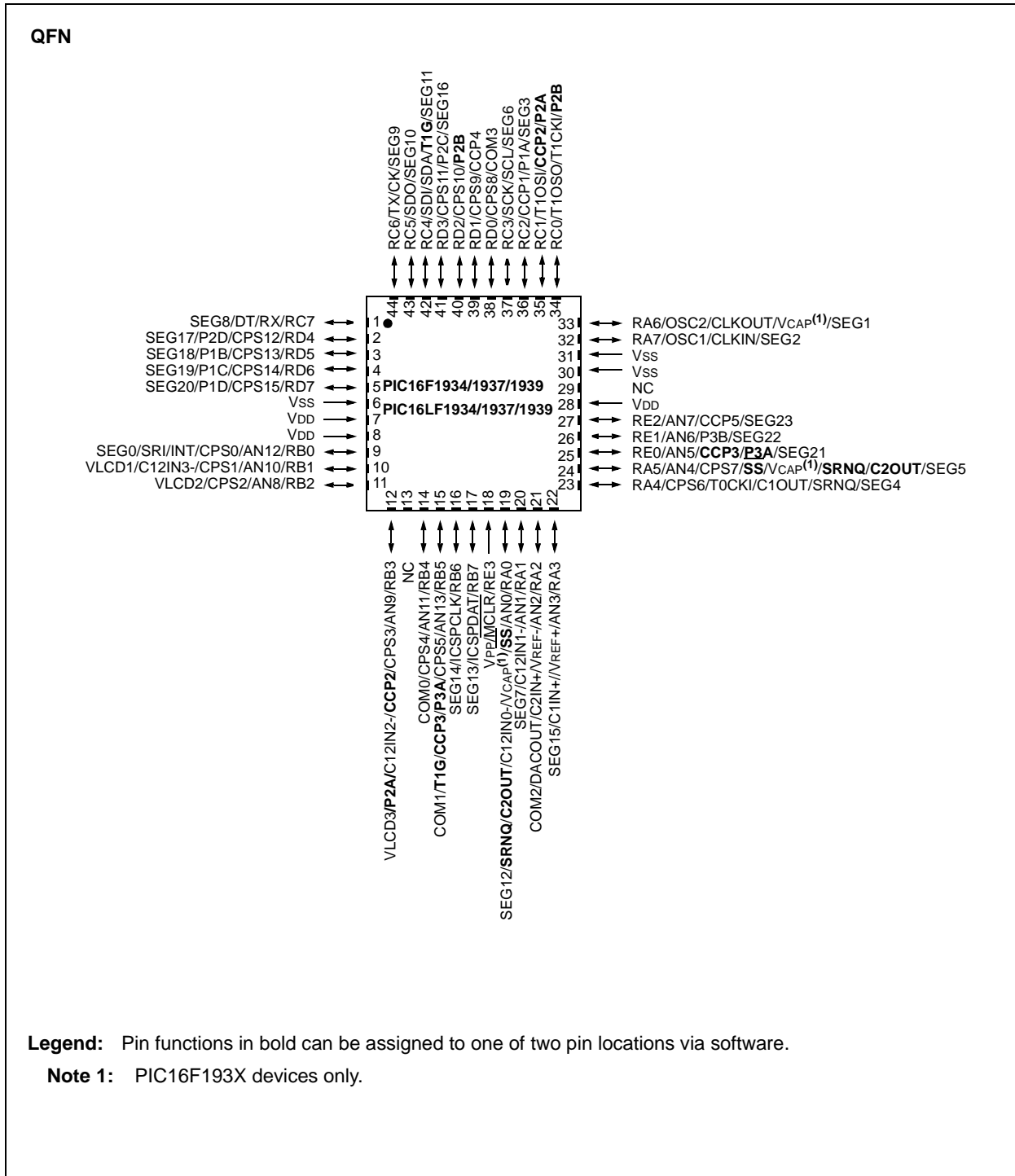

PIC16F193X/16LF193X

FIGURE 5: 44-PIN TQFP PACKAGE DIAGRAM FOR PIC16F1934/1937/1939 AND PIC16LF1934/1937/1939

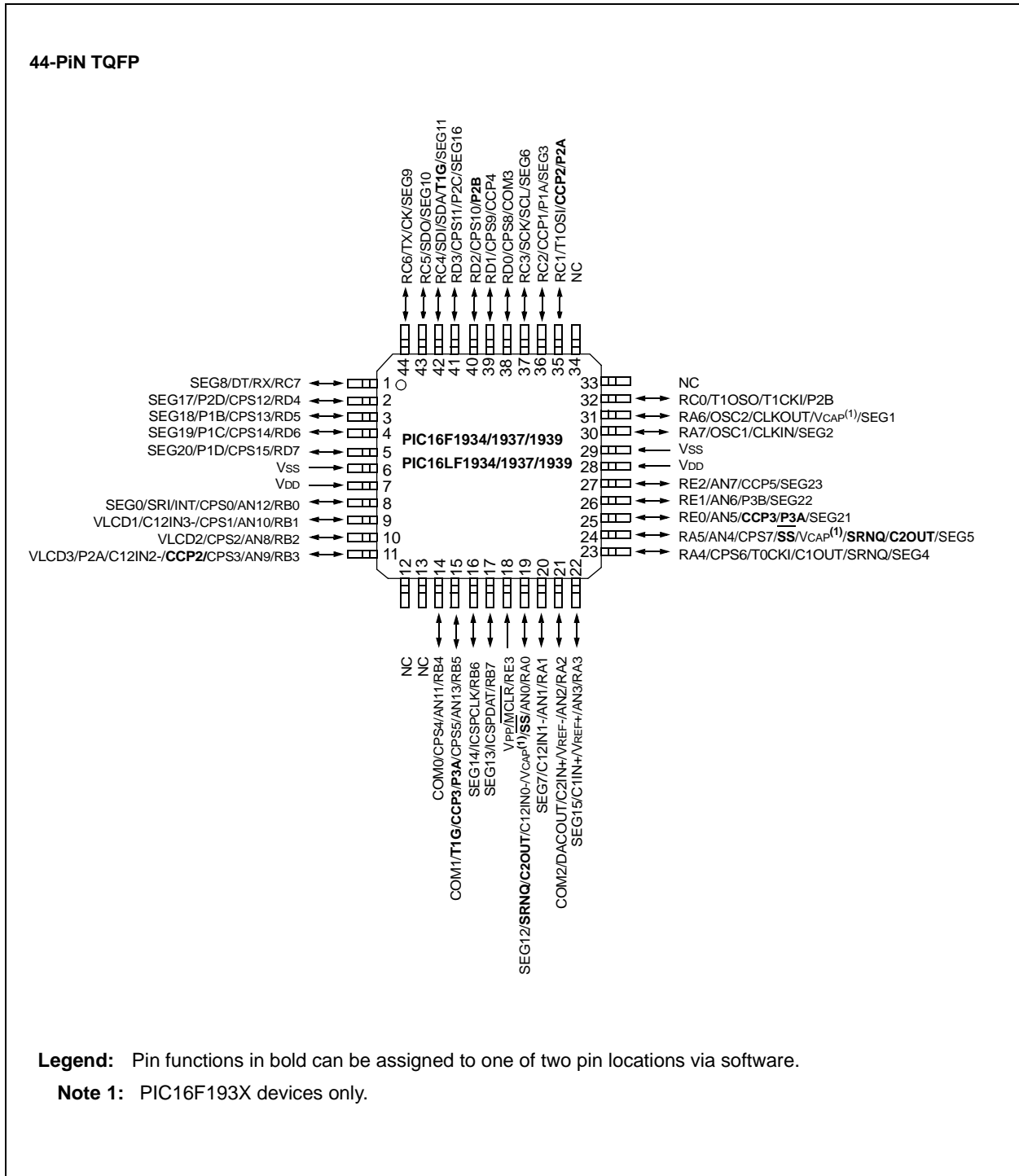

PIC16F193X/16LF193X

www.DataSheet4U.com

TABLE 3: 40/44-PIN ALLOCATION TABLE (PIC16F1934/1937/1939)

I/O	40-Pin PDIP	44-Pin TQFP	44-Pin QFN	A/D	Cap Sense	Comparator	SR Latch	Timers	CCP	EUSART	MSSP	LCD	Interrupt	Pull-up	Basic
RA0	2	19	19	AN0	—	C12IN0-/C2OUT ⁽¹⁾	SRNQ ⁽¹⁾	—	—	—	SS ⁽¹⁾	SEG12	—	—	VCAP
RA1	3	20	20	AN1	—	C12IN1-	—	—	—	—	—	SEG7	—	—	—
RA2	4	21	21	AN2/VREF-	—	C2IN+/DACOUT	—	—	—	—	—	COM2	—	—	—
RA3	5	22	22	AN3/VREF+	—	C1IN+	—	—	—	—	—	SEG15/COM3	—	—	—
RA4	6	23	23	—	CPS6	C1OUT	SRNQ	T0CKI	—	—	—	SEG4	—	—	—
RA5	7	24	24	AN4	CPS7	C2OUT ⁽¹⁾	SRNQ ⁽¹⁾	—	—	—	SS ⁽¹⁾	SEG5	—	—	VCAP
RA6	14	31	33	—	—	—	—	—	—	—	—	SEG1	—	—	OSC2/CLKOUT VCAP
RA7	13	30	32	—	—	—	—	—	—	—	—	SEG2	—	—	OSC1/CLKIN
RB0	33	8	9	AN12	CPS0	—	SRI	—	—	—	—	SEG0	INT/IOC	Y	—
RB1	34	9	10	AN10	CPS1	C12IN3-	—	—	—	—	—	VLCD1	IOC	Y	—
RB2	35	10	11	AN8	CPS2	—	—	—	—	—	—	VLCD2	IOC	Y	—
RB3	36	11	12	AN9	CPS3	C12IN2-	—	—	CCP2 ⁽¹⁾ / P2A ⁽¹⁾	—	—	VLCD3	IOC	Y	—
RB4	37	14	14	AN11	CPS4	—	—	—	—	—	—	COM0	IOC	Y	—
RB5	38	15	15	AN13	CPS5	—	—	T1G ⁽¹⁾	CCP3 ⁽¹⁾ / P3A ⁽¹⁾	—	—	COM1	IOC	Y	—
RB6	39	16	16	—	—	—	—	—	—	—	—	SEG14	IOC	Y	ICSPCLK
RB7	40	17	17	—	—	—	—	—	—	—	—	SEG13	IOC	Y	ICSPDAT
RC0	15	32	34	—	—	—	—	T1OSO/ T1CKI	P2B ⁽¹⁾	—	—	—	—	—	—
RC1	16	35	35	—	—	—	—	T1OSI	CCP2 ⁽¹⁾ / P2A ⁽¹⁾	—	—	—	—	—	—
RC2	17	36	36	—	—	—	—	—	CCP1/ P1A	—	—	SEG3	—	—	—
RC3	18	37	37	—	—	—	—	—	—	—	SCK/SCL	SEG6	—	—	—
RC4	23	42	42	—	—	—	—	T1G ⁽¹⁾	—	—	SDI/SDA	SEG11	—	—	—
RC5	24	43	43	—	—	—	—	—	—	—	SDO	SEG10	—	—	—
RC6	25	44	44	—	—	—	—	—	—	TX/CK	—	SEG9	—	—	—
RC7	26	1	1	—	—	—	—	—	—	RX/DT	—	SEG8	—	—	—
RD0	19	38	38	—	CPS8	—	—	—	—	—	—	COM3	—	—	—
RD1	20	39	39	—	CPS9	—	—	—	CCP4	—	—	—	—	—	—
RD2	21	40	40	—	CPS10	—	—	—	P2B ⁽¹⁾	—	—	—	—	—	—
RD3	22	41	41	—	CPS11	—	—	—	P2C	—	—	SEG16	—	—	—
RD4	27	2	2	—	CPS12	—	—	—	P2D	—	—	SEG17	—	—	—
RD5	28	3	3	—	CPS13	—	—	—	P1B	—	—	SEG18	—	—	—
RD6	29	4	4	—	CPS14	—	—	—	P1C	—	—	SEG19	—	—	—
RD7	30	5	5	—	CPS15	—	—	—	P1D	—	—	SEG20	—	—	—
RE0	8	25	25	AN5	—	—	—	—	CCP3 ⁽¹⁾ / P3A ⁽¹⁾	—	—	SEG21	—	—	—
RE1	9	26	26	AN6	—	—	—	—	P3B	—	—	SEG22	—	—	—
RE2	10	27	27	AN7	—	—	—	—	CCP5	—	—	SEG23	—	—	—
RE3	1	18	18	—	—	—	—	—	—	—	—	—	—	Y	MCLR/ VPP
VDD	11, 32	7, 28	7, 8, 28	—	—	—	—	—	—	—	—	—	—	—	VDD
VSS	12, 31	6, 29	6, 30, 31	—	—	—	—	—	—	—	—	—	—	—	VSS

Note 1: Pin functions can be assigned to one of two pin locations via software.

Note the following details of the code protection feature on Microchip devices:

- Microchip products meet the specification contained in their particular Microchip Data Sheet.
- Microchip believes that its family of products is one of the most secure families of its kind on the market today, when used in the intended manner and under normal conditions.
- There are dishonest and possibly illegal methods used to breach the code protection feature. All of these methods, to our knowledge, require using the Microchip products in a manner outside the operating specifications contained in Microchip's Data Sheets. Most likely, the person doing so is engaged in theft of intellectual property.
- Microchip is willing to work with the customer who is concerned about the integrity of their code.
- Neither Microchip nor any other semiconductor manufacturer can guarantee the security of their code. Code protection does not mean that we are guaranteeing the product as "unbreakable."

Code protection is constantly evolving. We at Microchip are committed to continuously improving the code protection features of our products. Attempts to break Microchip's code protection feature may be a violation of the Digital Millennium Copyright Act. If such acts allow unauthorized access to your software or other copyrighted work, you may have a right to sue for relief under that Act.

Information contained in this publication regarding device applications and the like is provided only for your convenience and may be superseded by updates. It is your responsibility to ensure that your application meets with your specifications. MICROCHIP MAKES NO REPRESENTATIONS OR WARRANTIES OF ANY KIND WHETHER EXPRESS OR IMPLIED, WRITTEN OR ORAL, STATUTORY OR OTHERWISE, RELATED TO THE INFORMATION, INCLUDING BUT NOT LIMITED TO ITS CONDITION, QUALITY, PERFORMANCE, MERCHANTABILITY OR FITNESS FOR PURPOSE. Microchip disclaims all liability arising from this information and its use. Use of Microchip devices in life support and/or safety applications is entirely at the buyer's risk, and the buyer agrees to defend, indemnify and hold harmless Microchip from any and all damages, claims, suits, or expenses resulting from such use. No licenses are conveyed, implicitly or otherwise, under any Microchip intellectual property rights.

Trademarks

The Microchip name and logo, the Microchip logo, Accuron, dsPIC, KEELOQ, KEELOQ logo, MPLAB, PIC, PICmicro, PICSTART, rfPIC, SmartShunt and UNI/O are registered trademarks of Microchip Technology Incorporated in the U.S.A. and other countries.

FilterLab, Linear Active Thermistor, MXDEV, MXLAB, SEEVAL, SmartSensor and The Embedded Control Solutions Company are registered trademarks of Microchip Technology Incorporated in the U.S.A.

Analog-for-the-Digital Age, Application Maestro, CodeGuard, dsPICDEM, dsPICDEM.net, dsPICworks, dsSPEAK, ECAN, ECONOMONITOR, FanSense, In-Circuit Serial Programming, ICSP, ICEPIC, Mindi, MiWi, MPASM, MPLAB Certified logo, MPLIB, MPLINK, mTouch, PICkit, PICDEM, PICDEM.net, PICtail, PIC³² logo, PowerCal, PowerInfo, PowerMate, PowerTool, REAL ICE, rfLAB, Select Mode, Total Endurance, WiperLock and ZENA are trademarks of Microchip Technology Incorporated in the U.S.A. and other countries.

SQTP is a service mark of Microchip Technology Incorporated in the U.S.A.

All other trademarks mentioned herein are property of their respective companies.

© 2008, Microchip Technology Incorporated, Printed in the U.S.A., All Rights Reserved.

 Printed on recycled paper.

**QUALITY MANAGEMENT SYSTEM
CERTIFIED BY DNV
== ISO/TS 16949:2002 ==**

Microchip received ISO/TS-16949:2002 certification for its worldwide headquarters, design and wafer fabrication facilities in Chandler and Tempe, Arizona; Gresham, Oregon and design centers in California and India. The Company's quality system processes and procedures are for its PIC[®] MCUs and dsPIC[®] DSCs, KEELOQ[®] code hopping devices, Serial EEPROMs, microperipherals, nonvolatile memory and analog products. In addition, Microchip's quality system for the design and manufacture of development systems is ISO 9001:2000 certified.



MICROCHIP

WORLDWIDE SALES AND SERVICE

AMERICAS

Corporate Office
2355 West Chandler Blvd.
Chandler, AZ 85224-6199
Tel: 480-792-7200
Fax: 480-792-7277
Technical Support:
http://support.microchip.com
Web Address:
www.microchip.com

Atlanta
Duluth, GA
Tel: 678-957-9614
Fax: 678-957-1455

Boston
Westborough, MA
Tel: 774-760-0087
Fax: 774-760-0088

Chicago
Itasca, IL
Tel: 630-285-0071
Fax: 630-285-0075

Dallas
Addison, TX
Tel: 972-818-7423
Fax: 972-818-2924

Detroit
Farmington Hills, MI
Tel: 248-538-2250
Fax: 248-538-2260

Kokomo
Kokomo, IN
Tel: 765-864-8360
Fax: 765-864-8387

Los Angeles
Mission Viejo, CA
Tel: 949-462-9523
Fax: 949-462-9608

Santa Clara
Santa Clara, CA
Tel: 408-961-6444
Fax: 408-961-6445

Toronto
Mississauga, Ontario,
Canada
Tel: 905-673-0699
Fax: 905-673-6509

ASIA/PACIFIC

Asia Pacific Office
Suites 3707-14, 37th Floor
Tower 6, The Gateway
Harbour City, Kowloon
Hong Kong
Tel: 852-2401-1200
Fax: 852-2401-3431

Australia - Sydney
Tel: 61-2-9868-6733
Fax: 61-2-9868-6755

China - Beijing
Tel: 86-10-8528-2100
Fax: 86-10-8528-2104

China - Chengdu
Tel: 86-28-8665-5511
Fax: 86-28-8665-7889

China - Hong Kong SAR
Tel: 852-2401-1200
Fax: 852-2401-3431

China - Nanjing
Tel: 86-25-8473-2460
Fax: 86-25-8473-2470

China - Qingdao
Tel: 86-532-8502-7355
Fax: 86-532-8502-7205

China - Shanghai
Tel: 86-21-5407-5533
Fax: 86-21-5407-5066

China - Shenyang
Tel: 86-24-2334-2829
Fax: 86-24-2334-2393

China - Shenzhen
Tel: 86-755-8203-2660
Fax: 86-755-8203-1760

China - Wuhan
Tel: 86-27-5980-5300
Fax: 86-27-5980-5118

China - Xiamen
Tel: 86-592-2388138
Fax: 86-592-2388130

China - Xian
Tel: 86-29-8833-7252
Fax: 86-29-8833-7256

China - Zhuhai
Tel: 86-756-3210040
Fax: 86-756-3210049

ASIA/PACIFIC

India - Bangalore
Tel: 91-80-4182-8400
Fax: 91-80-4182-8422

India - New Delhi
Tel: 91-11-4160-8631
Fax: 91-11-4160-8632

India - Pune
Tel: 91-20-2566-1512
Fax: 91-20-2566-1513

Japan - Yokohama
Tel: 81-45-471- 6166
Fax: 81-45-471-6122

Korea - Daegu
Tel: 82-53-744-4301
Fax: 82-53-744-4302

Korea - Seoul
Tel: 82-2-554-7200
Fax: 82-2-558-5932 or
82-2-558-5934

Malaysia - Kuala Lumpur
Tel: 60-3-6201-9857
Fax: 60-3-6201-9859

Malaysia - Penang
Tel: 60-4-227-8870
Fax: 60-4-227-4068

Philippines - Manila
Tel: 63-2-634-9065
Fax: 63-2-634-9069

Singapore
Tel: 65-6334-8870
Fax: 65-6334-8850

Taiwan - Hsin Chu
Tel: 886-3-572-9526
Fax: 886-3-572-6459

Taiwan - Kaohsiung
Tel: 886-7-536-4818
Fax: 886-7-536-4803

Taiwan - Taipei
Tel: 886-2-2500-6610
Fax: 886-2-2508-0102

Thailand - Bangkok
Tel: 66-2-694-1351
Fax: 66-2-694-1350

EUROPE

Austria - Wels
Tel: 43-7242-2244-39
Fax: 43-7242-2244-393

Denmark - Copenhagen
Tel: 45-4450-2828
Fax: 45-4485-2829

France - Paris
Tel: 33-1-69-53-63-20
Fax: 33-1-69-30-90-79

Germany - Munich
Tel: 49-89-627-144-0
Fax: 49-89-627-144-44

Italy - Milan
Tel: 39-0331-742611
Fax: 39-0331-466781

Netherlands - Drunen
Tel: 31-416-690399
Fax: 31-416-690340

Spain - Madrid
Tel: 34-91-708-08-90
Fax: 34-91-708-08-91

UK - Wokingham
Tel: 44-118-921-5869
Fax: 44-118-921-5820

01/02/08