

HD26C32A

Quadruple Differential Line Drivers With 3 State Outputs

REJ03D0293-0200Z
(Previous ADE-205-575 (Z))
Rev.2.00
Jul.16.2004

Description

The HD26C32A provides differential line receivers which realize low power dissipation by CMOS process. The device has four receivers which meet the requirements of EIA standard RS-422A and RS-423A in a 16 pin package.

The enable function is common to all four receivers and offers a choice of active high or active low inputs. Fail safe design ensures that if the inputs are open the outputs will always be high.

Features

- Low power dissipation with CMOS process
- Meets EIA standard RS-422A/423A
- Input sensitivity: $\pm 0.2V$ (In the range of $\pm 7 V$ of common mode input voltage)
- Propagation delay time: 19 ns typ
- Input hysteresis width: 60 mV typ
- Three state outputs
- Differential Inputs are includes fail safe circuit
- Power up and power down protection
- Pin to pin compatible with HD26LS32/32A
- Ordering Information

Part Name	Package Type	Package Code	Package Abbreviation	Taping Abbreviation (Quantity)
HD26C32AP	DILP-16 pin (JEITA)	DP-16E, -16FV	P	—
HD26C32AFPEL	SOP-16 pin (JEITA)	FP-16DAV	FP	EL (2,000 pcs/reel)

Note: Please consults the sales office for the above package availability.

Pin Arrangement

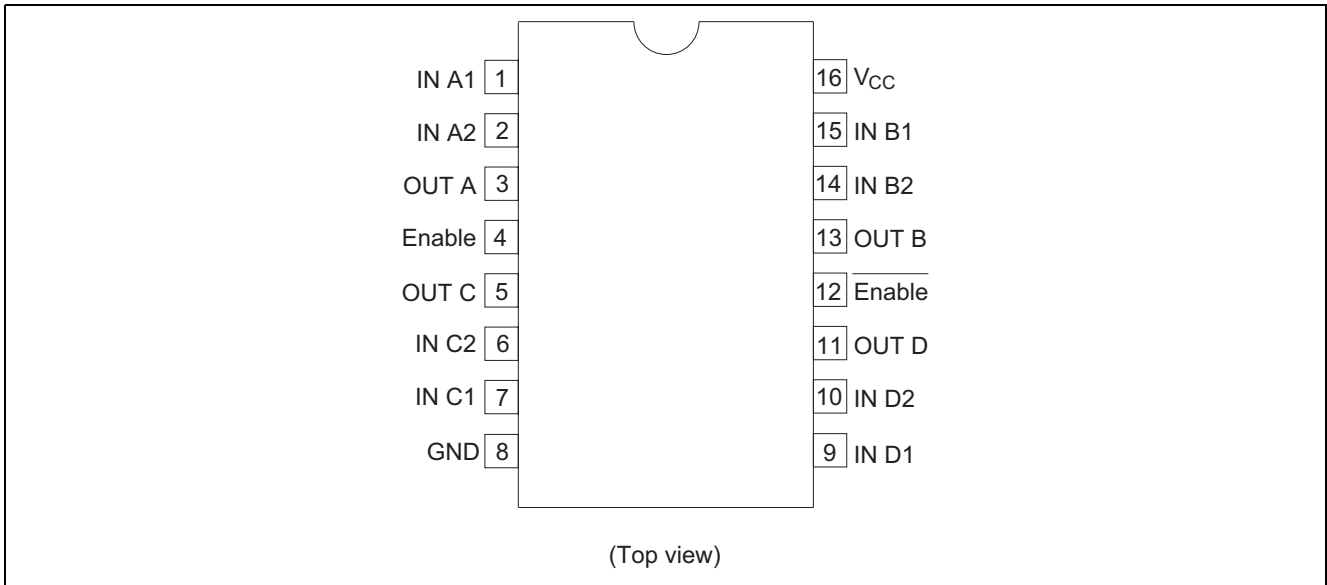

Function Table

Differential Input	Enable	$\overline{\text{Enable}}$	Outputs
$V_{ID} \geq V_{TH}$ or OPEN	H	X	H
	X	L	
$V_{TL} < V_{ID} < V_{TH}$	H	X	?
	X	L	
$V_{ID} \geq V_{TH}$	H	X	L
	X	L	
X	L	H	Z

- H : High level
- L : Low level
- Z : High impedance
- X : Irrelevant
- ? : Indeterminate

Absolute Maximum Ratings (Ta = 25°C)

Item	Symbol	Ratings	Unit
Supply Voltage*2	V_{CC}	7	V
Common Mode Input Voltage	V_{CM}	± 14	V
Differential Input Voltage*3	V_{DIFF}	± 14	V
Enable Input Voltage	V_{IN}	7	V
Output Current	I_O	± 25	mA
Storage Temperature	Tstg	-65 to +150	°C

- Notes:
1. The absolute maximum ratings are values which must not individually be exceeded, and furthermore, no two of which may be realized at the same time.
 2. All voltage values except for differential input voltage are with respect to network ground terminal.
 3. Differential input voltage is measured at the noninverting input with respect to the corresponding inverting input.

Recommended Operating Conditions (Ta = -40°C to +85°C)

Item	Symbol	Min	Typ	Max	Unit
Supply Voltage	V _{CC}	4.5	5.0	5.5	V
Common Mode Input Voltage	V _{CM}	—	—	±7	V
Differential Input Voltage	V _{DIFF}	—	—	±7	V
Output Current	I _O	—	—	±6	mA
Operating Temperature	Topr	-40	—	85	°C
Enable Input Rise / Fall Time	t _r , t _f	—	—	500	ns

Note: 1. This item guarantees maximum limit when one input switches.

Waveform: Refer to test circuit of switching characteristics.

Logic Diagram

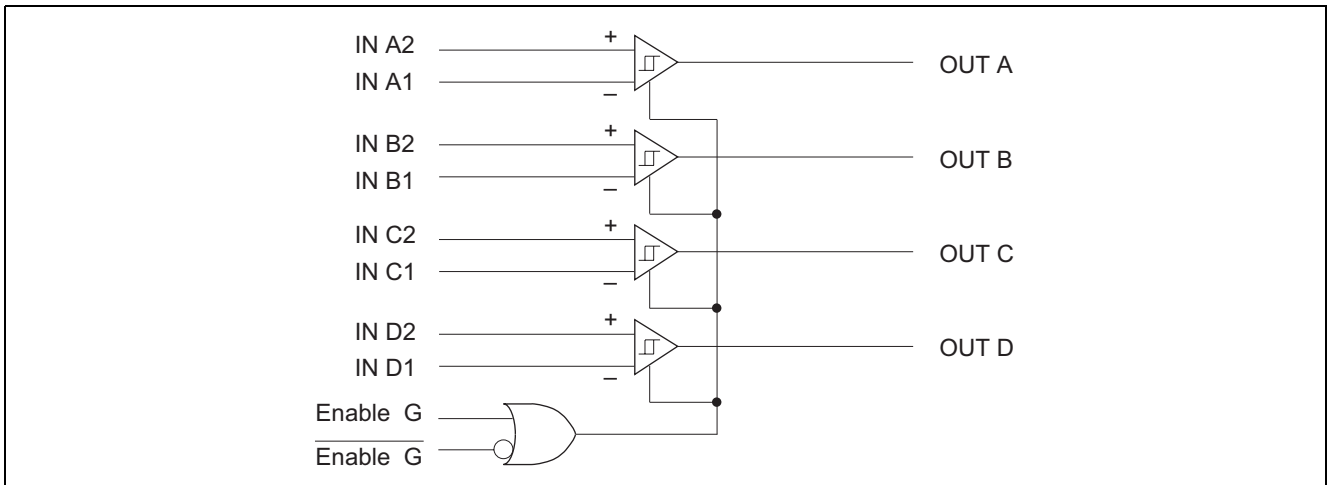

Electrical Characteristics (Ta = -40°C to +85°C, V_{CC} = 5 V ± 10%)

Item	Symbol	Min	Typ	Max	Unit	Conditions
Differential Input Threshold Voltage	V _{TH}	—	—	0.2	V	V _{CM} = -7 to 7 V, V _{OUT} ≥ 3.8 V
	V _{TL}	—	—	-0.2	V	V _{CM} = -7 to 7 V, V _{OUT} ≤ 0.3 V
Input Hysteresis	V _{HYST}	—	60	—	mV	V _{CM} = 0 V
Enable Input Voltage	V _{IH}	2.0	—	—	V	
	V _{IL}	—	—	0.8	V	
Output Voltage	V _{OH}	3.8	4.2	—	V	V _{CC} = 4.5 V, V _{DIEF} = 1 V, I _{OUT} = -6.0 mA
	V _{OL}	—	0.2	0.3	V	V _{CC} = 5.5 V, V _{DIEF} = -1 V, I _{OUT} = 6.0 mA
Output Leak Current	I _{OZ}	—	0.5	5.0	μA	Enable = 0.8 V, $\overline{\text{Enable}} = 2.0 \text{ V}$ V _{OUT} = V _{CC}
		—	-0.5	-5.0	μA	Enable = 0.8 V, $\overline{\text{Enable}} = 2.0 \text{ V}$ V _{OUT} = GND
Input Current	I _{IN}	—	1.1	1.5	mA	V _{IN} = 10 V, Other Input = GND
		-0.1*1	—	0.6	mA	V _{IN} = 3 V, Other Input = GND
		0	—	-1.1	mA	V _{IN} = -3 V, Other Input = GND
		—	-2.0	-2.5	mA	V _{IN} = -10 V, Other Input = GND
Enable Input Current	I _I	—	—	1.0	μA	V _I = V _{CC}
		—	—	-1.0	μA	V _I = GND
Input Resistance	R _{IN}	5.8	6.8	10	kΩ	V _{CM} = -7 to 7 V (One Input AC GND)
Supply Current	I _{CC}	—	16	23	mA	V _{CC} = 5.5 V, V _{DIEF} = 1 V

Note: 1. This specification is nonstandard of RS-422A.

Switching Characteristics (Ta = -40°C to +85°C, V_{CC} = 5 V ± 10%)

Item	Symbol	Min	Typ	Max	Unit	Conditions
Propagation Delay Time	t _{PLH}	7	16	25	ns	C _L = 50 pF, V _{DIEF} = 2.5 V, V _{CM} = 0 V
	t _{PHL}	7	16	25	ns	
Output Rise / Fall Time	t _{RISE}	—	4	9	ns	C _L = 50 pF, V _{DIEF} = 2.5 V, V _{CM} = 0 V
	t _{FALL}	—	4	9	ns	
Output Disable Time	t _{LZ}	—	13	22	ns	C _L = 50 pF, R _L = 1000 Ω V _{DIEF} = 2.5 V
	t _{HZ}	—	13	22	ns	
Output Enable Time	t _{ZL}	—	13	22	ns	C _L = 50 pF, R _L = 1000 Ω V _{DIEF} = 2.5 V
	t _{ZH}	—	13	22	ns	

1. t_{PLH}, t_{PHL}, t_{RISE}, t_{FALL}

Test Circuit

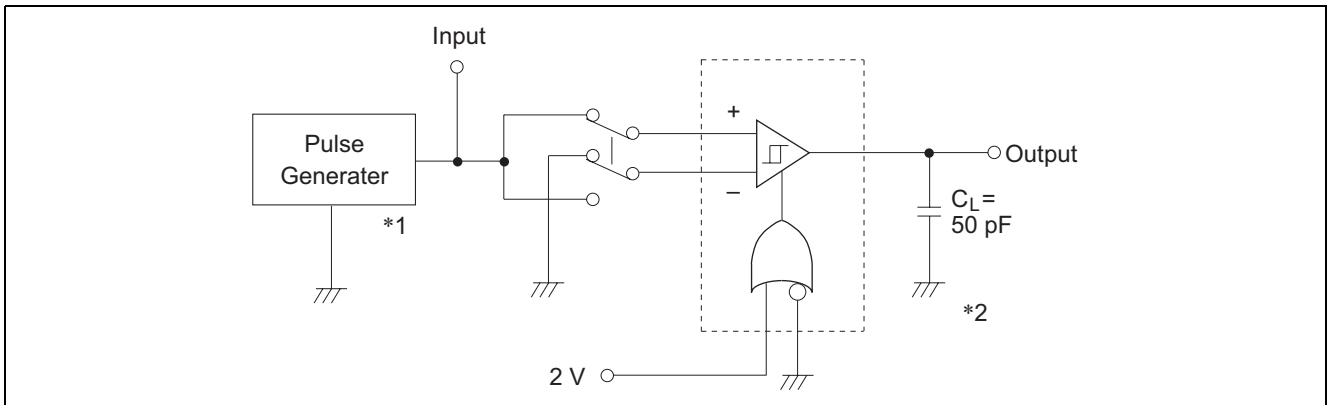

Wave forms

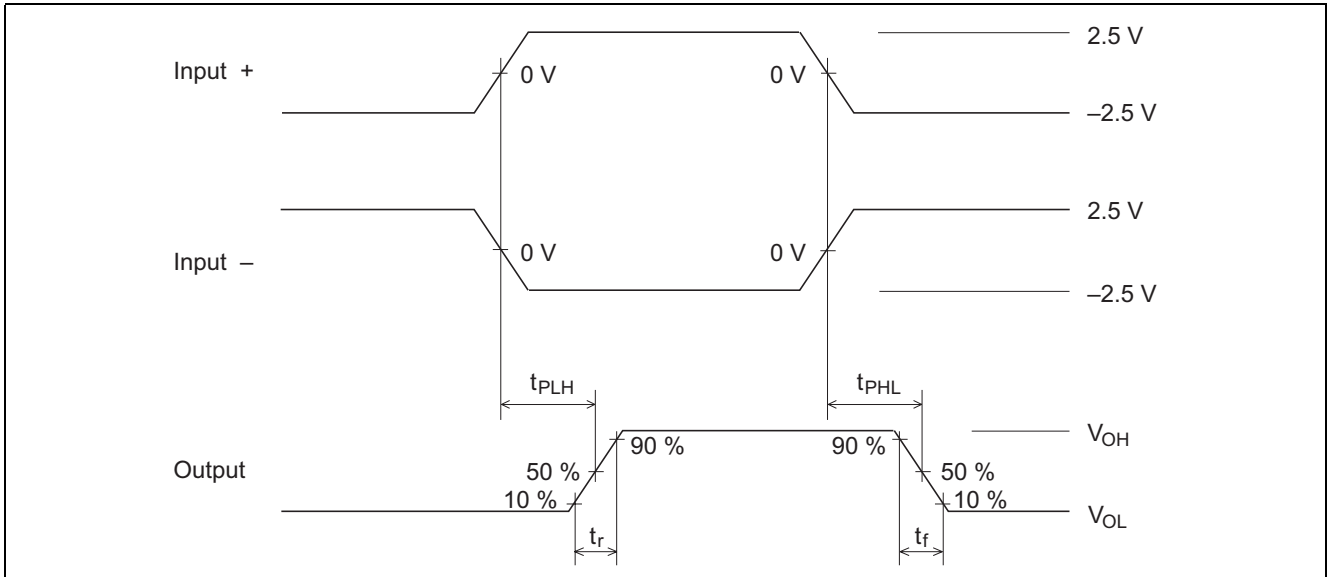

2. t_{HZ} , t_{ZH}

Test Circuit

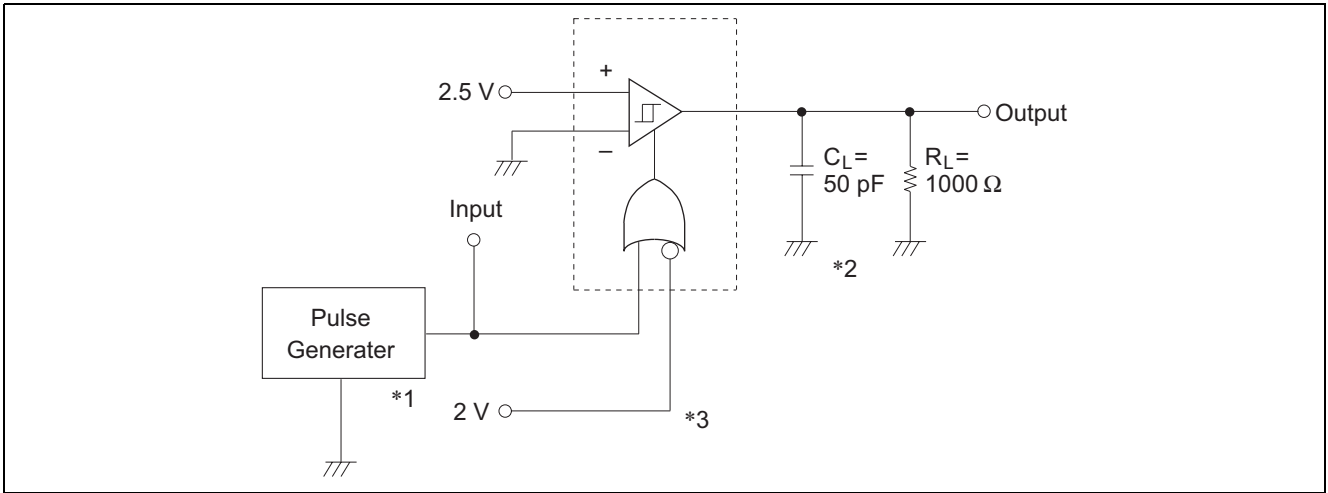

Wave forms

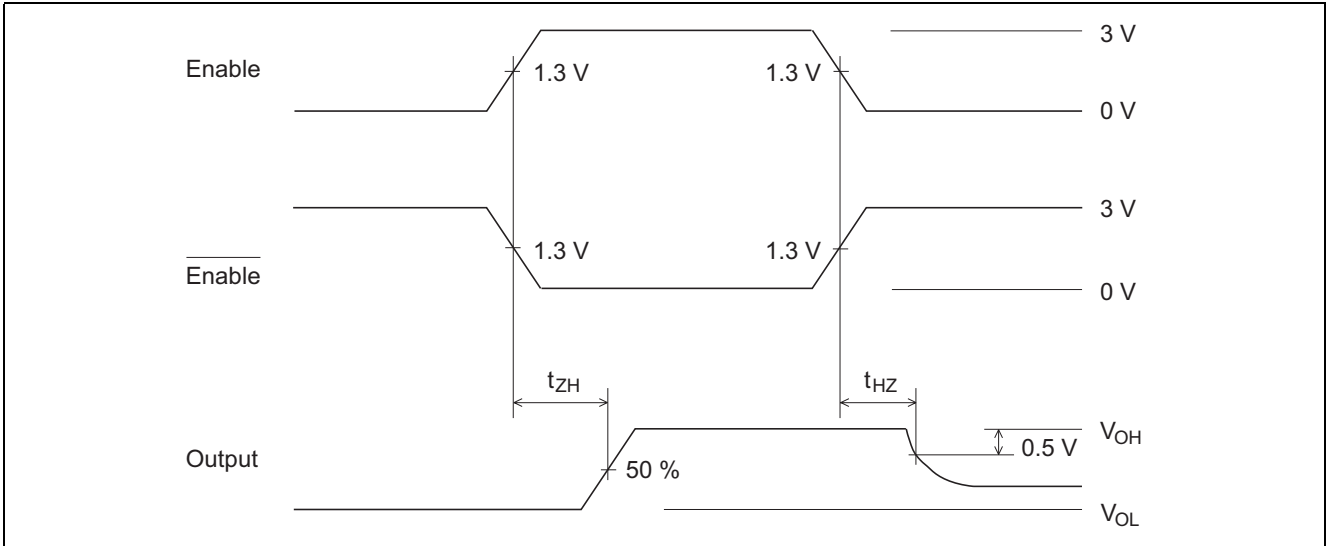

3. t_{LZ} , t_{ZL}

Test circuit

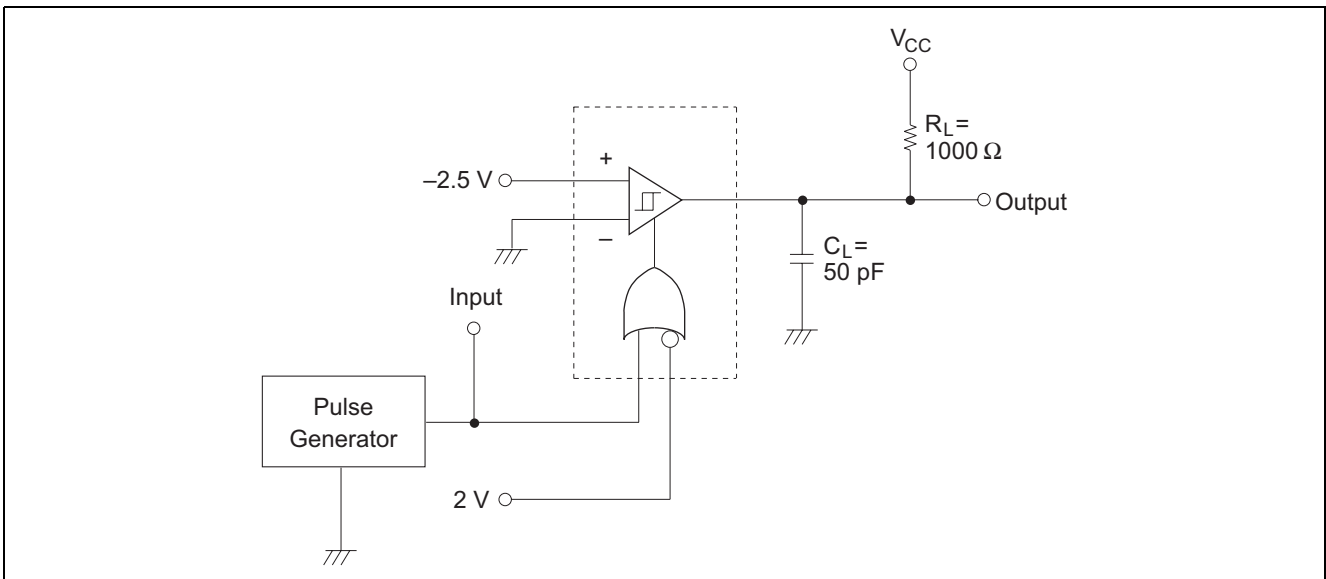

Wave forms

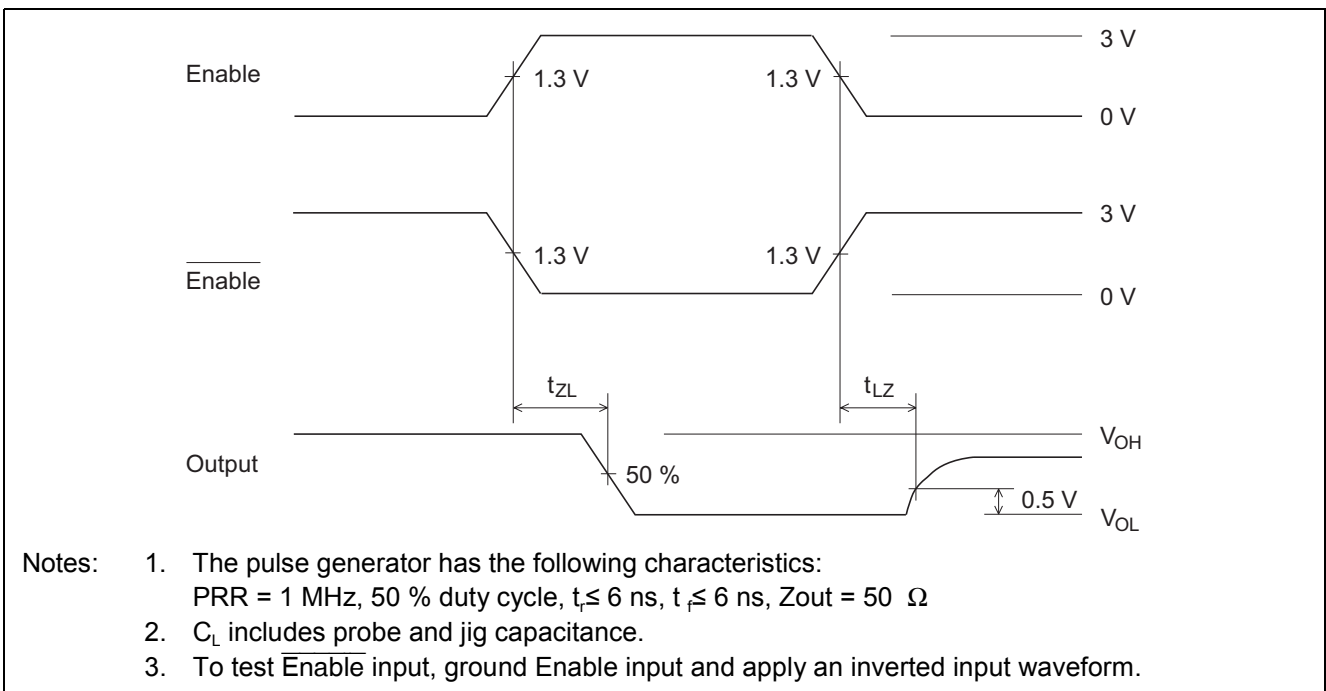

HD26C32A Line Receiver Applications

The HD26C32A is a line receiver that meets the EIA RS-422A and RS-423A conditions. It has a high in-phase input voltage range, both positive and negative, enabling highly reliable transmission to be performed even in noisy environments.

Its main features are listed below.

- Operates on a single 5 V power supply.
- ± 0.2 V input sensitivity in in-phase input voltage ± 7 V range
- Three-state output
- On-chip input fail-safe circuit
- On-chip power up/down protection circuit

As shown by the logic diagram, the enable function is common to all four drivers, and either active-high or active-low input can be selected.

When exchange is carried out using a party line system, it is better to keep the receiver input bias current constituting the driver load small, as this allows more receivers to be connected.

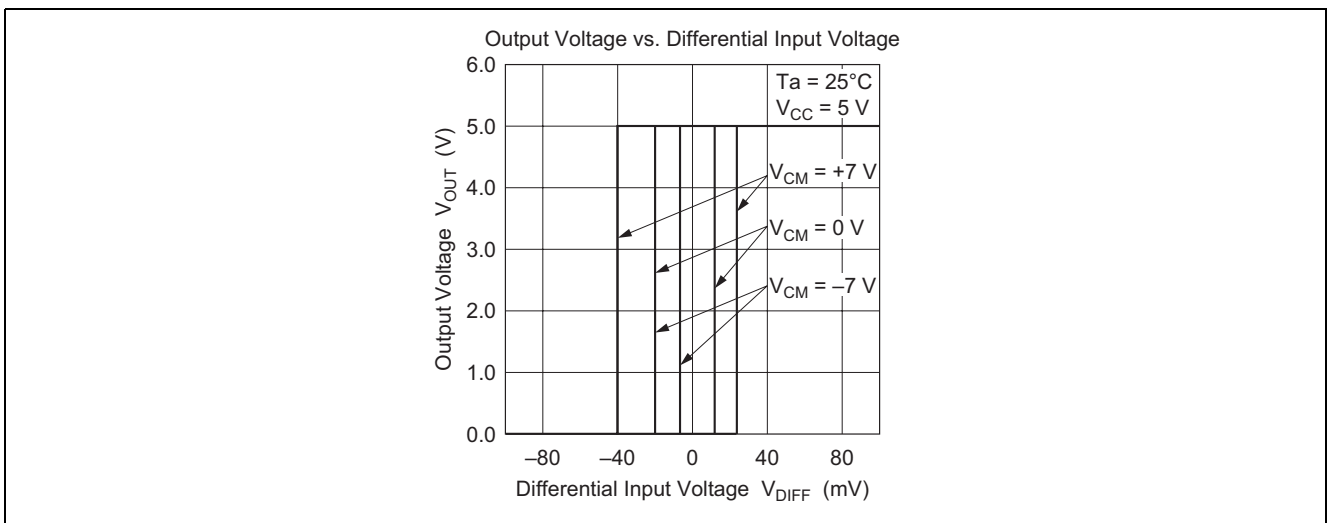

Figure 1 Differential Input Voltage vs. Output Voltage Characteristics

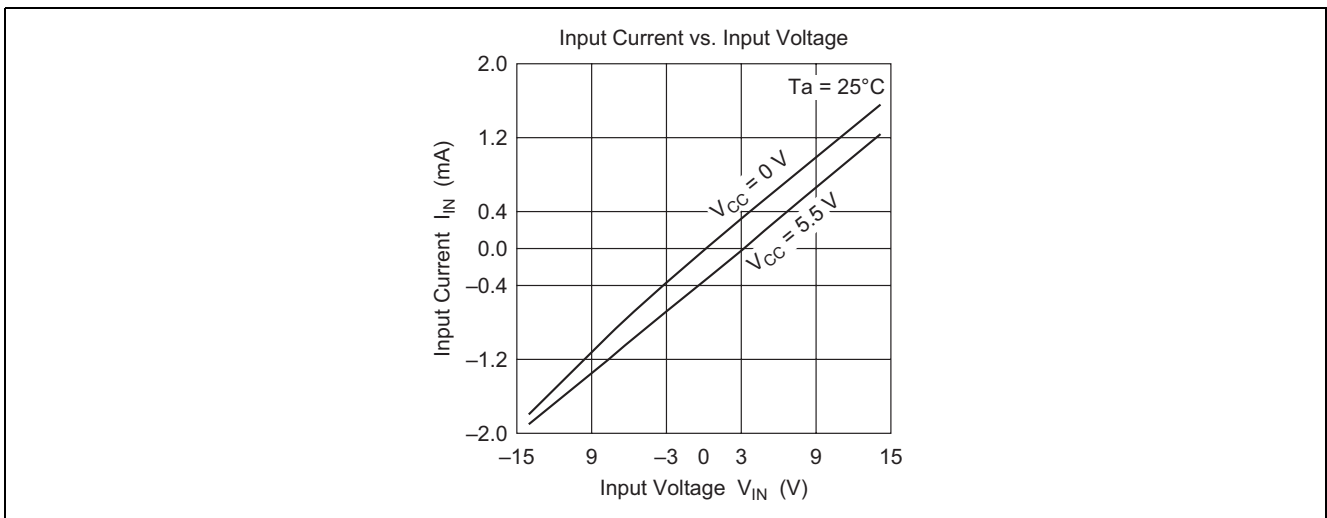

Figure 2 Input Voltage vs. Input Current Characteristics

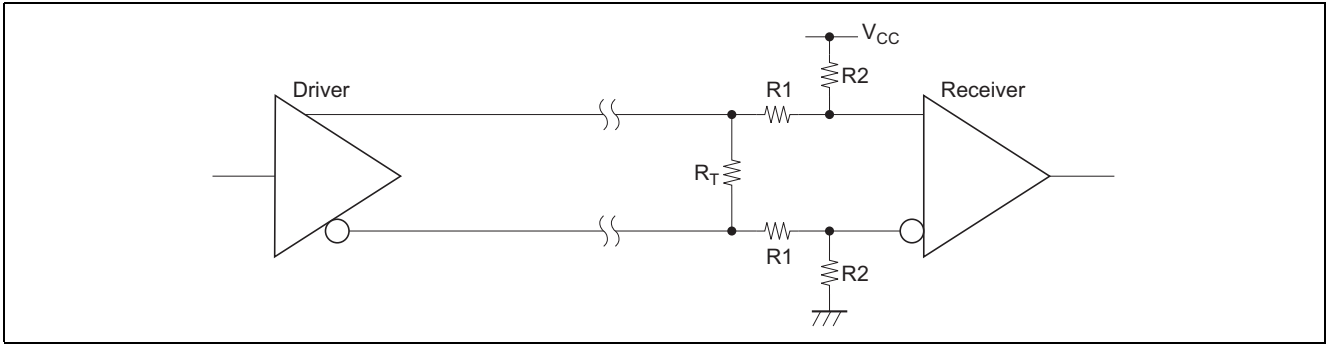

Figure 3 Method of Enhancing Fail-Safe Function

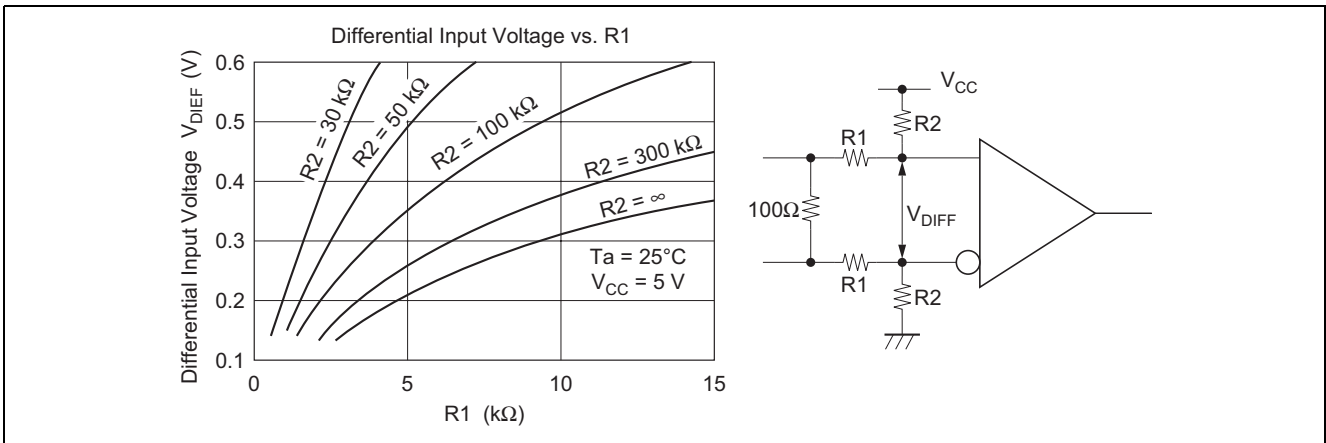

Figure 4 R_1 , R_2 vs. Differential Input Voltage

1. Unidirectional Transmission (1 : 1 Configuration)

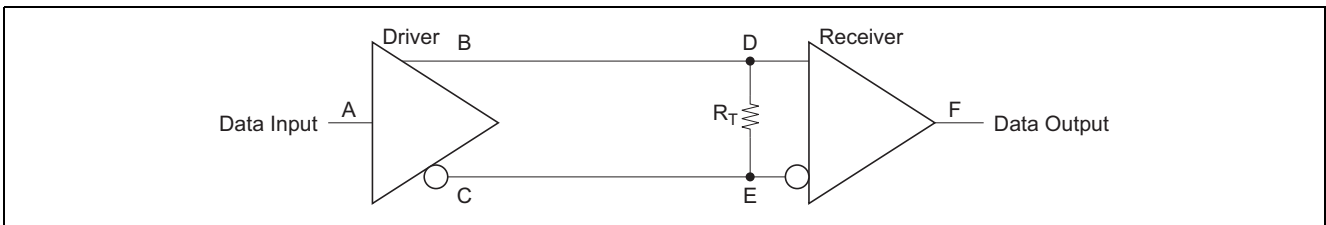

Figure 5 1 : 1 Unidirectional Transmission

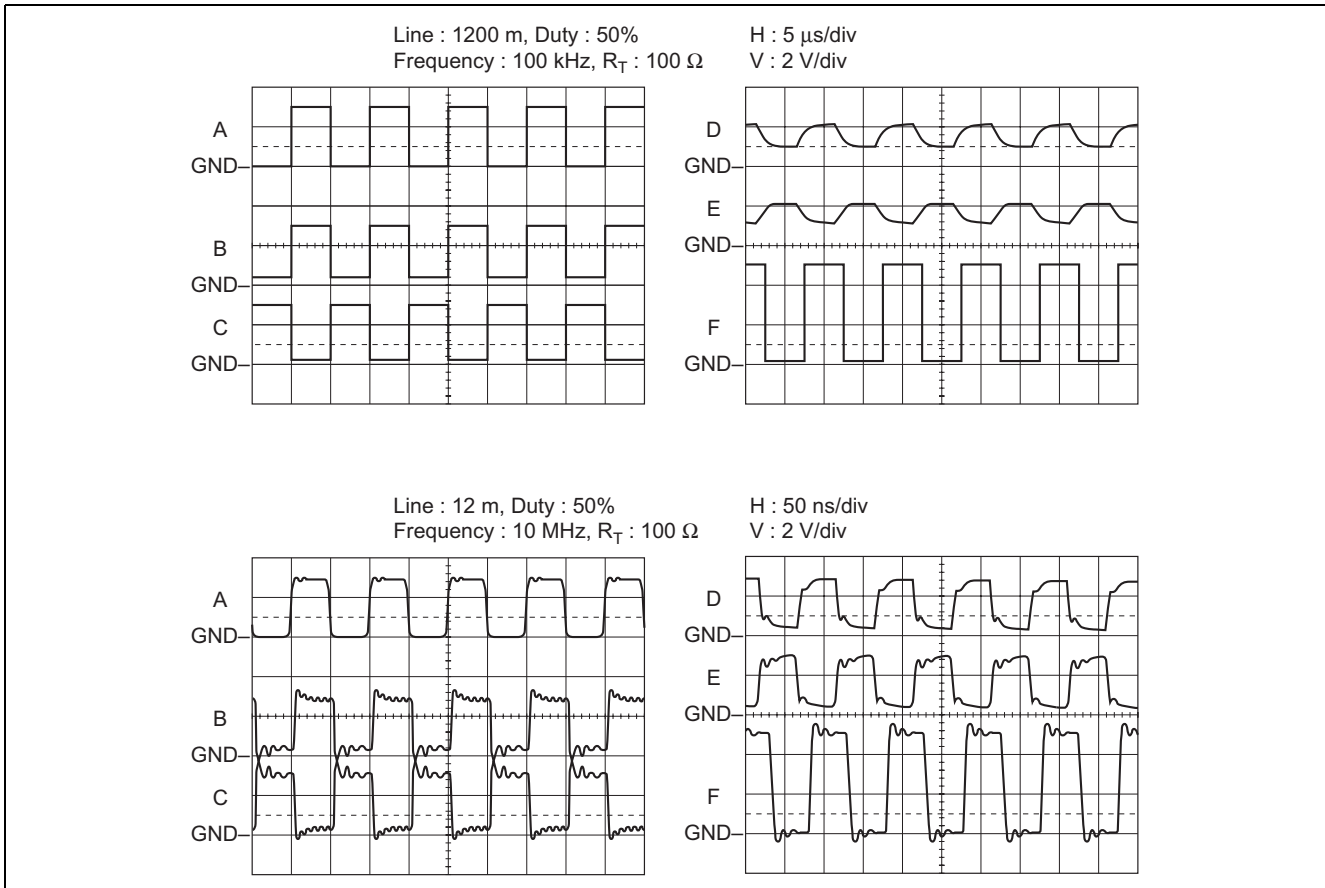

Figure 6 Sample Transmission Waveforms

2. Unidirectional Transmission (1 : n Configuration)

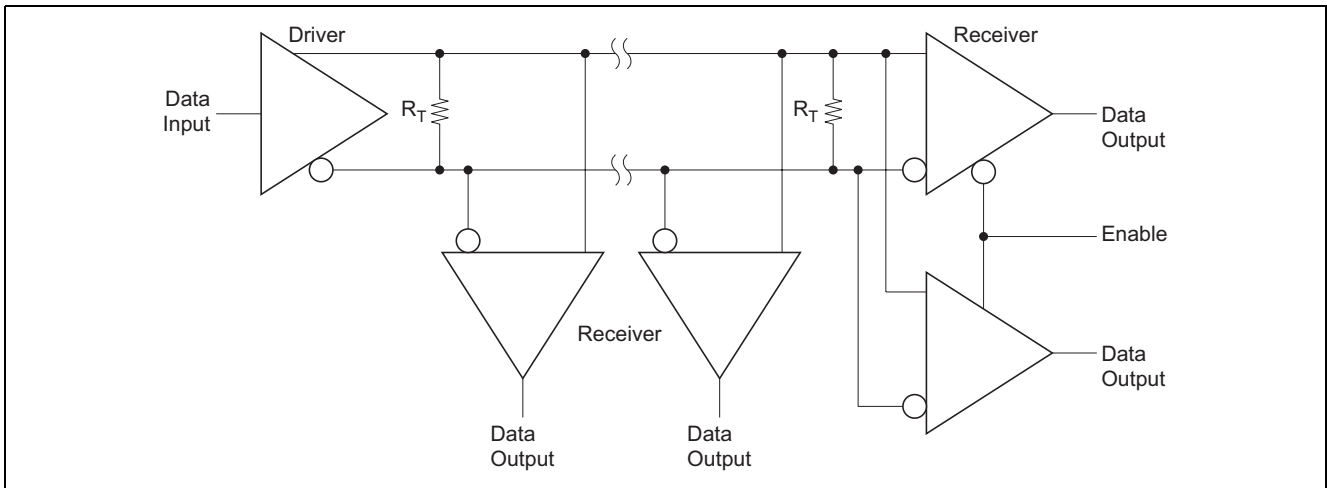

Figure 7 1:n Unidirectional Transmission

With this connection method, n receivers are connected for one driver. In the RS-422A standard, ten receivers can be connected simultaneously for one driver.

Conversely, it is also possible to connect one receiver for n drivers.

3. Bidirectional Transmission

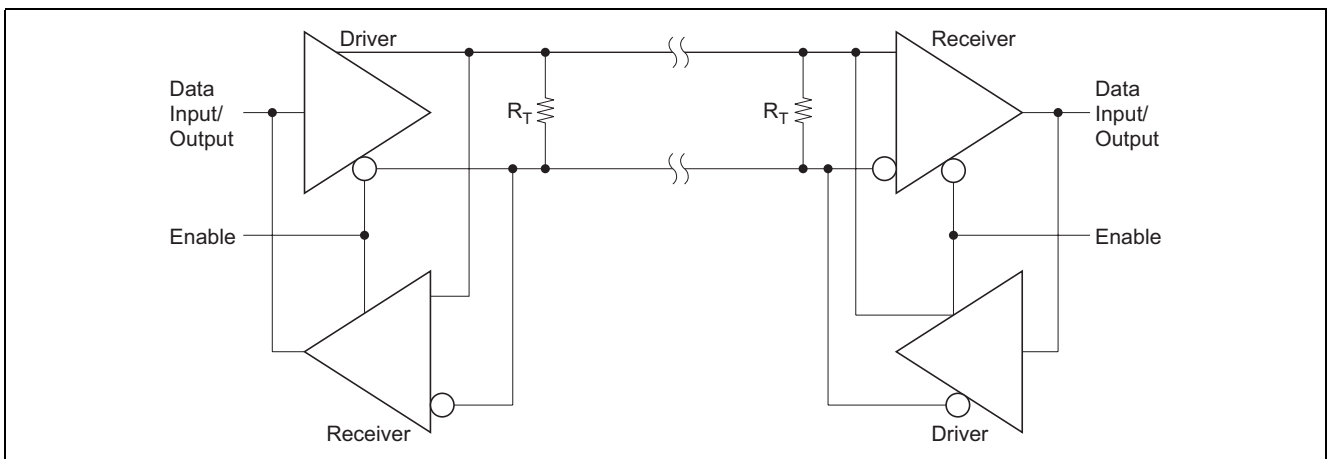

Figure 8 Bidirectional Transmission

When bidirectional data exchange is performed using a combination of the HD26C31 and HD26C32A, since either high or low output control is possible, using complementary enable inputs for the driver and receiver makes it easy to configure the kind of combination illustrated in figure 8.

Extending this combination makes it possible to exchange n-bit data simultaneously, and handle a party line system.

Package Dimensions

As of January, 2003
Unit: mm

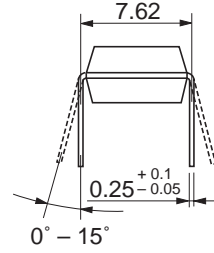
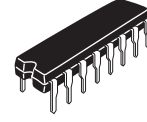
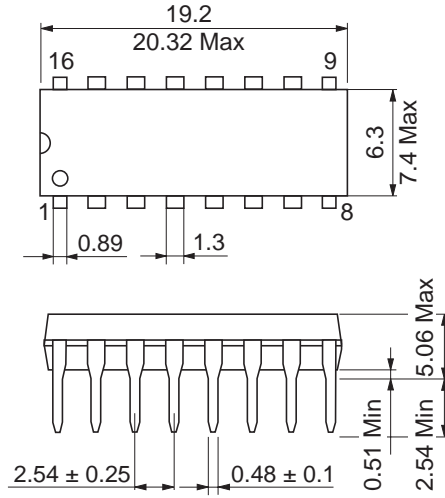

Package Code	DP-16E
JEDEC	Conforms
JEITA	Conforms
Mass (reference value)	1.05 g

Unit: mm

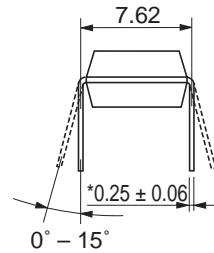
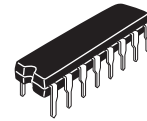
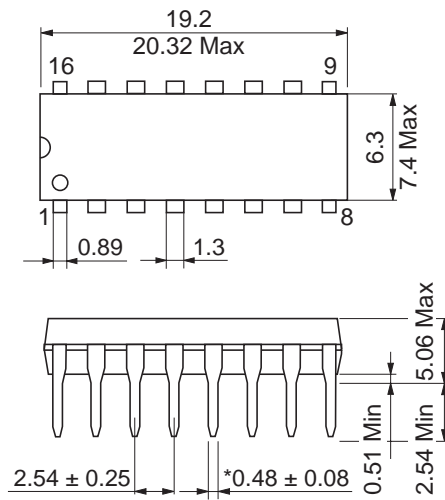

*NI/Pd/AU Plating

Package Code	DP-16FV
JEDEC	Conforms
JEITA	Conforms
Mass (reference value)	1.05 g

As of January, 2003

Unit: mm

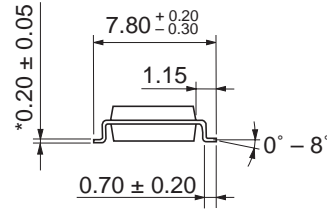
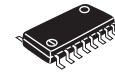
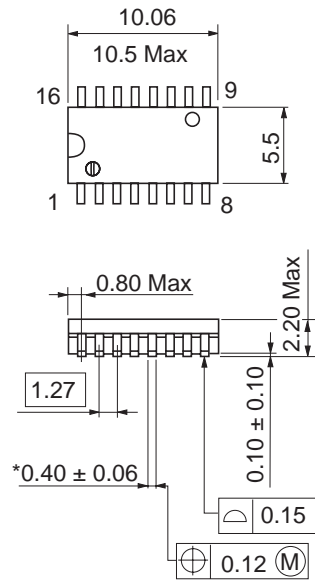

*Ni/Pd/Au plating

Package Code	FP-16DAV
JEDEC	—
JEITA	Conforms
Mass (reference value)	0.24 g

Renesas Technology Corp. Sales Strategic Planning Div. Nippon Bldg., 2-6-2, Ohte-machi, Chiyoda-ku, Tokyo 100-0004, Japan

Keep safety first in your circuit designs!

1. Renesas Technology Corp. puts the maximum effort into making semiconductor products better and more reliable, but there is always the possibility that trouble may occur with them. Trouble with semiconductors may lead to personal injury, fire or property damage. Remember to give due consideration to safety when making your circuit designs, with appropriate measures such as (i) placement of substitutive, auxiliary circuits, (ii) use of nonflammable material or (iii) prevention against any malfunction or mishap.

Notes regarding these materials

1. These materials are intended as a reference to assist our customers in the selection of the Renesas Technology Corp. product best suited to the customer's application; they do not convey any license under any intellectual property rights, or any other rights, belonging to Renesas Technology Corp. or a third party.
 2. Renesas Technology Corp. assumes no responsibility for any damage, or infringement of any third-party's rights, originating in the use of any product data, diagrams, charts, programs, algorithms, or circuit application examples contained in these materials.
 3. All information contained in these materials, including product data, diagrams, charts, programs and algorithms represents information on products at the time of publication of these materials, and are subject to change by Renesas Technology Corp. without notice due to product improvements or other reasons. It is therefore recommended that customers contact Renesas Technology Corp. or an authorized Renesas Technology Corp. product distributor for the latest product information before purchasing a product listed herein.
The information described here may contain technical inaccuracies or typographical errors.
Renesas Technology Corp. assumes no responsibility for any damage, liability, or other loss rising from these inaccuracies or errors.
Please also pay attention to information published by Renesas Technology Corp. by various means, including the Renesas Technology Corp. Semiconductor home page (<http://www.renesas.com>).
 4. When using any or all of the information contained in these materials, including product data, diagrams, charts, programs, and algorithms, please be sure to evaluate all information as a total system before making a final decision on the applicability of the information and products. Renesas Technology Corp. assumes no responsibility for any damage, liability or other loss resulting from the information contained herein.
 5. Renesas Technology Corp. semiconductors are not designed or manufactured for use in a device or system that is used under circumstances in which human life is potentially at stake. Please contact Renesas Technology Corp. or an authorized Renesas Technology Corp. product distributor when considering the use of a product contained herein for any specific purposes, such as apparatus or systems for transportation, vehicular, medical, aerospace, nuclear, or undersea repeater use.
 6. The prior written approval of Renesas Technology Corp. is necessary to reprint or reproduce in whole or in part these materials.
 7. If these products or technologies are subject to the Japanese export control restrictions, they must be exported under a license from the Japanese government and cannot be imported into a country other than the approved destination.
Any diversion or reexport contrary to the export control laws and regulations of Japan and/or the country of destination is prohibited.
 8. Please contact Renesas Technology Corp. for further details on these materials or the products contained therein.
-



RENESAS SALES OFFICES

<http://www.renesas.com>

Renesas Technology America, Inc.

450 Holger Way, San Jose, CA 95134-1368, U.S.A
Tel: <1> (408) 382-7500 Fax: <1> (408) 382-7501

Renesas Technology Europe Limited.

Dukes Meadow, Millboard Road, Bourne End, Buckinghamshire, SL8 5FH, United Kingdom
Tel: <44> (1628) 585 100, Fax: <44> (1628) 585 900

Renesas Technology Europe GmbH

Dornacher Str. 3, D-85622 Feldkirchen, Germany
Tel: <49> (89) 380 70 0, Fax: <49> (89) 929 30 11

Renesas Technology Hong Kong Ltd.

7/F., North Tower, World Finance Centre, Harbour City, Canton Road, Hong Kong
Tel: <852> 2265-6688, Fax: <852> 2375-6836

Renesas Technology Taiwan Co., Ltd.

FL 10, #99, Fu-Hsing N. Rd., Taipei, Taiwan
Tel: <886> (2) 2715-2888, Fax: <886> (2) 2713-2999

Renesas Technology (Shanghai) Co., Ltd.

26/F., Ruijin Building, No.205 Maoming Road (S), Shanghai 200020, China
Tel: <86> (21) 6472-1001, Fax: <86> (21) 6415-2952

Renesas Technology Singapore Pte. Ltd.

1, Harbour Front Avenue, #06-10, Keppel Bay Tower, Singapore 098632
Tel: <65> 6213-0200, Fax: <65> 6278-8001