

Transistors

High transition frequency (dual transistors)

EMX5 / UMX5N / IMX5

●Features

- 1) Two 2SC3838K chips in a EMT or UMT or SMT package.
- 2) High transition frequency. ($f_t=3.2\text{GHz}$)
- 3) Low output capacitance. ($C_{ob}=0.9\text{pF}$)

●Equivalent circuits

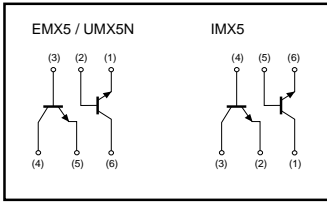

●Absolute maximum ratings ($T_a=25^\circ\text{C}$)

Parameter	Symbol	Limits	Unit
Collector-base voltage	V_{CBO}	20	V
Collector-emitter voltage	V_{CEO}	11	V
Emitter-base voltage	V_{EBO}	3	V
Collector current	I_C	50	mA
Collector power dissipation	EMX5 / UMX5N	P_C 150(TOTAL)	mW *1
	IMX5	300(TOTAL)	mW *2
Junction temperature	T_j	150	$^\circ\text{C}$
Storage temperature	T_{stg}	-55~+150	$^\circ\text{C}$

*1 120mW per element must not be exceeded.
*2 200mW per element must not be exceeded.

●Package, marking, and packaging specifications

Type	EMX5	UMX5N	IMX5
Package	EMT5	UMT6	SMT6
Marking	X5	X5	X5
Code	T2R	TR	T108
Basic ordering unit (pieces)	8000	3000	3000

●External dimensions (Units : mm)

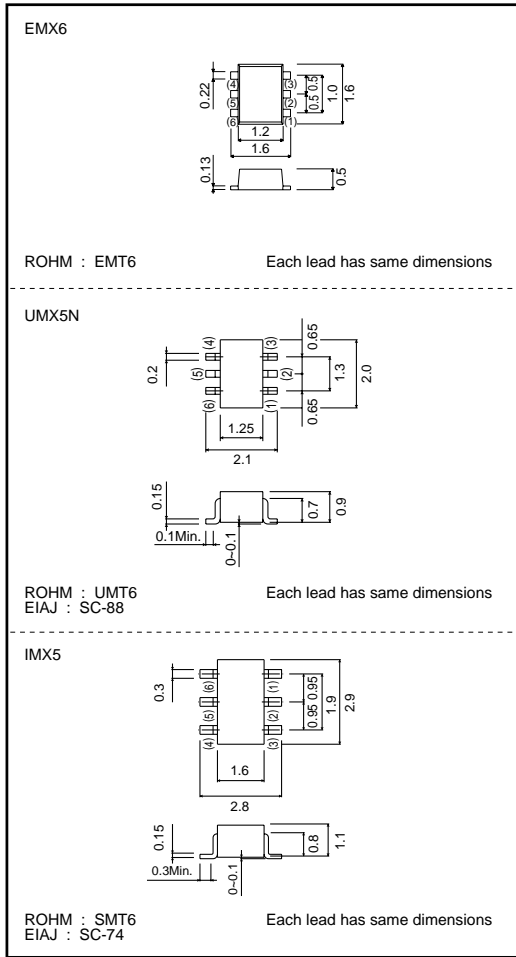

●Electrical characteristics ($T_a=25^\circ\text{C}$)

Parameter	Symbol	Min.	Typ.	Max.	Unit	Conditions
Collector-base breakdown voltage	BV_{CBO}	20	-	-	V	$I_C=10\mu\text{A}$
Collector-emitter breakdown voltage	BV_{CEO}	11	-	-	V	$I_C=1\text{mA}$
Emitter-base breakdown voltage	BV_{EBO}	3	-	-	V	$I_E=10\mu\text{A}$
Collector cutoff current	I_{CBO}	-	-	0.5	μA	$V_{CB}=10\text{V}$
Emitter cutoff current	I_{EBO}	-	-	0.5	μA	$V_{EB}=2\text{V}$
DC current transfer ratio	h_{FE}	27	-	270	-	$V_{CE}/I_C=10\text{V}/5\text{mA}$
Collector-emitter saturation voltage	$V_{CE(sat)}$	-	-	0.5	V	$I_C/I_B=10\text{mA}/5\text{mA}$
h_{FE} pairing	h_{FE1} / h_{FE2}	0.5	1	2	-	$V_{CE}/I_C=10\text{V}/5\text{mA}$
Transition frequency	f_t	1.4	3.2	-	GHz	$V_{CE}/I_C=10\text{V}/10\text{mA}$, $f=200\text{MHz}$ *
Output capacitance	C_{ob}	-	0.9	1.55	pF	$V_{CB}/f=10\text{V}/1\text{MHz}$, $I_E=0\text{A}$

*Transition frequency of the device.

