

## **CANSTAR Fiber Optic Couplers**



Created in 1989, FCI - an Areva Group company - rapidly secured its place among the world's top three manufacturers of connectors and interconnect systems. With a turnover of 1.8 billion dollars in 2001, FCI currently operates in 29 countries where it covers the following markets: communications, data, consumer, industrial, military, aerospace and electrical power interconnect. The company employs 16,000 staff worldwide.

For more information, visit the website at [www.fciconnect.com](http://www.fciconnect.com)

For specific information on FCI's Fiber Optic products, visit [www.fciconnect.com/products/fiberoptics](http://www.fciconnect.com/products/fiberoptics)

### FCI Fiber Optics

FCI acquired Canstar in 1997. With new clean-room manufacturing and R&D facilities, FCI Fiber Optics is committed to developing, manufacturing and selling Canstar fiber optic couplers to a worldwide market.

FCI reserves the right to make any engineering refinements, alterations or improvements deemed necessary on its products. The dimensions appearing in this catalogue are thus subject to change without notice. When dimensions are critical detailed drawings should be requested.

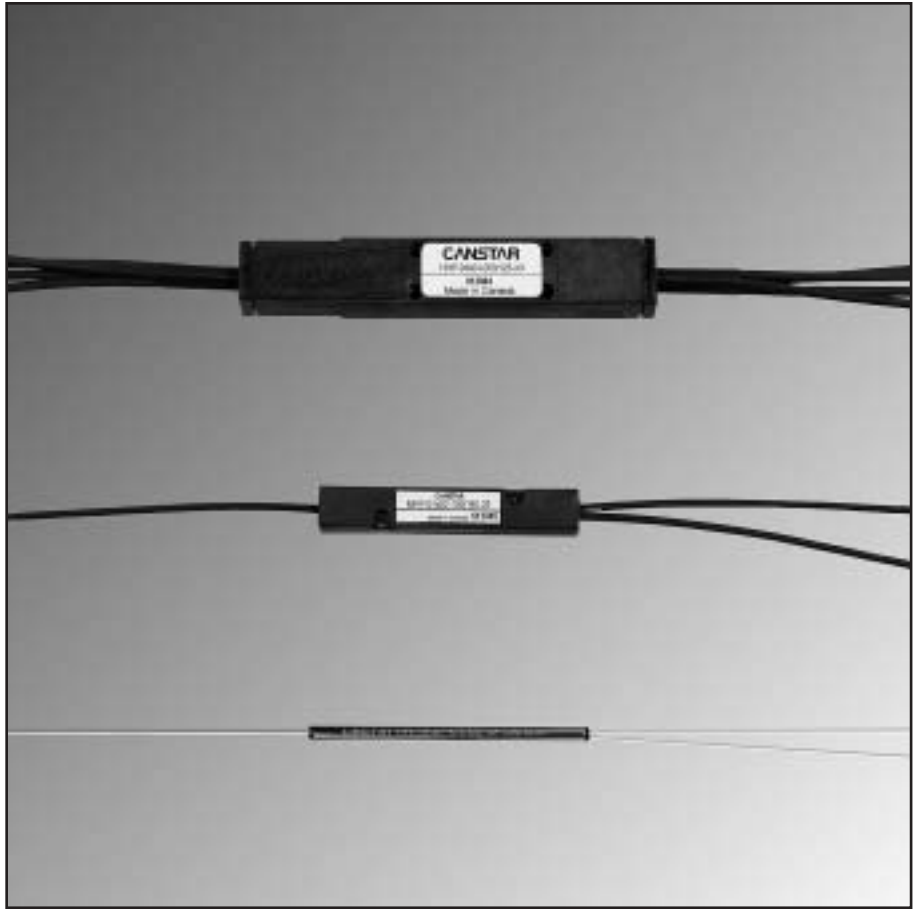

### Table of Contents

Catalogue Organization and General Information.....	3
Singlemode Couplers - 1x2 and 2x2 Couplers.....	4
Singlemode Couplers - 1x2 Couplers Wideband .....	8
Singlemode Couplers - 1x3 and 1x4 Couplers.....	11
Singlemode Couplers - 1xN and 2xN Concatenated Couplers.....	13
Singlemode 1x2 WDMs .....	17
Singlemode Attenuators .....	19
Multimode Couplers - 1x2 and 2x2 Couplers.....	21
Multimode Couplers - MxN Star Couplers.....	25
Connectorized Fiber Optic Couplers .....	28

## Canstar Fiber Optic Couplers

### Organization of this Catalogue

This catalogue covers a wide range of components and options.

The first seven sections describe the fiber optic coupler products. The next section covers connectorized fiber optic cable assemblies. The final section explains how to order fiber optic couplers with factory installed connectors.

All specifications are subject to change without notice.

### Specifying a Fiber Optic Coupler Part Number

All fiber optic couplers (with or without connectors) have a common part numbering structure, which is shown in the ordering information section on each product. To identify the elements of specifying a part number, please consider the following questions:

- 1) What type of optical fiber will the coupler be used with? If singlemode fiber, which type? If multimode fiber, what is the core/cladding/coating diameters? Is it graded or step index?
- 2) What are the number of inputs and outputs?
- 3) If singlemode - what is the operational wavelength(s) and range?
- 4) If it is a tap coupler, what tap ratio is required?
- 5) What degree of ruggedization of cable leads is required? Keep in mind, the more rugged the larger the enclosure.
- 6) Are nonstandard lead lengths required?
- 7) Are connectors required on the leads? If so, which type?

Our customer service staff will be pleased to help you answer these questions to define the correct component for your application.

### Benefits of Canstar couplers

Proven coupler technology (see sidebar)  
 Key patents and licenses  
 Proven product designs  
 Proven innovators  
 Proven manufacturing capability  
 Proven quality

### A History of Tapered Fiber Optic Components

The 1970s was the decade of development of the first commercially practical optical fibers, cables, components and systems. Advance technology research at the Communications Research Center (CRC) in Ottawa, Canada, was investigating principles for fiber optic branching devices.

A key breakthrough in 1977 resulted in the invention of the Fused Biconically Tapered (FBT) coupler - a two fiber device where each fiber had a tapered section that was fused to the other fiber. Some of the light in the first fiber coupled into the adjacent fiber.

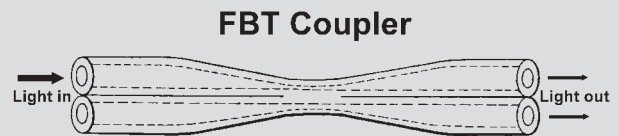

Canstar was developing technology for pioneering fiber optic system projects in Canada. In collaboration with CRC, Canstar developed the FBT coupler technology into a commercial product and introduced it to the market in 1978. The benefits of FBT coupler technology rapidly displaced the alternatives of the time, propelling Canstar to the forefront of the fiber optic component marketplace.

Many technical advances have been made in FBT technology over the last two decades resulting in the following products:

- introduction of multimode taps and splitters
- introduction of singlemode taps and splitters
- introduction of multimode star couplers
- introduction of singlemode WDMs
- introduction of wideband singlemode couplers
- introduction of singlemode star couplers
- introduction of taper fiber attenuators
- introduction of taper fiber filters
- introduction of narrowband WDMs and dense WDMs

Canstar has been at the forefront of most of these advances and is proud to offer you a full range of fiber optic coupler products.

Canstar couplers are used in every application of fiber optic technology: telecommunications to data communications, medical to military, commercial aircraft to railway, and from down to Earth industrial to satellites in orbit.

**Please talk to us about your application.**

## Fiber Optic Singlemode Couplers 1x2 and 2x2 Couplers

Canstar 1x2 and 2x2 singlemode Couplers are designed for use in test equipment and optical networks. Optimum performance and operation under adverse environmental conditions are achieved through licensed use of fused biconical taper coupler patents, with proprietary refinements combined with rigorous quality control.

### Features and Benefits

- Low insertion loss.
- High directivity.
- Bidirectional.
- Range of coupling ratios.
- Wide band and dual window versions available.
- Stable over wide temperature range.
- Range of housing options.
- Optional connectorized leads.
- PC board mountable.

Photographs and drawings shown depict 1x2 Couplers. The same dimensions apply for 2x2 Couplers

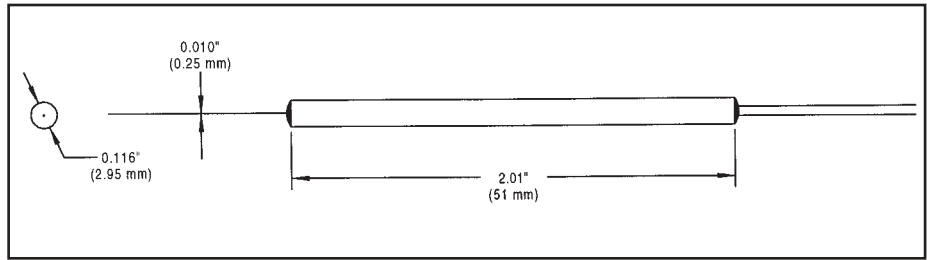

BS - type, 250  $\mu$ m coated fiber leads for most compact size.

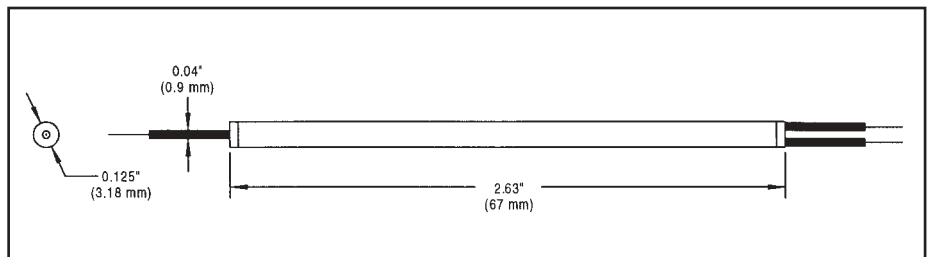

FL - type, 900  $\mu$ m buffer tube leads for added protection.

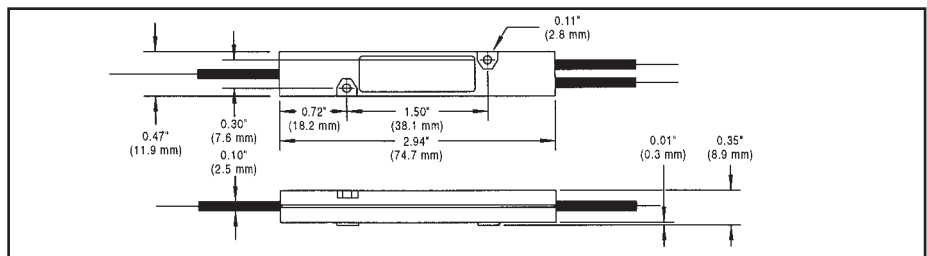

RP - type, 2.5 mm reinforced jacket for rugged use.



## Specifications for Standard Singlemode 1x2 Couplers

Coupling:	Please refer to the following table.	
Optical Fiber(s):	SMF28™ (except single wavelength couplers use HI780™ or HI1060™)	
Directivity:	≥ 50dB	
Thermal Sensitivity:	≤ +/- 0.2 dB (-40 to +85°C)	
Dimensions:	Please refer to drawings on previous page.	
Standard Lead Lengths:	BS-type (250µm coating)	Lead length (nom) = 1m
	FL-type (0.9mm TFE tube)	Lead length (nom) = 55cm
	RP-type (2.5mm Reinforced Jacket)	Lead length (nom) = 55cm

SMF28™, HI780™, and HI1060™ are registered trademarks of Corning Inc.  
 \* Optional lead lengths are available. Consult factory for leadlength options and information

Part Number (see note 1)	Part Descriptor	Wavelength (nm)	Coupling Ratio (%)	Maximum Excess Loss (dB)	Maximum Insertion Loss (dB)
<b>Single Wavelength Couplers</b>					
58052-001-ZZ	CZZ-01x-02-085/XXX-50B	850	50 +/- 5	0.5	4.0
58052-002-ZZ	CZZ-01x-02-098/XXX-50C	980	50 +/- 5	0.5	4.0
<b>Single Window Couplers</b>					
58052-101-ZZ	VZZ-01x02-130/XXX-50A	1300 +/- 20	50 +/- 3	0.3	3.6
58052-102-ZZ	VZZ-01x02-130/XXX-40A	1300 +/- 20	40 +/- 3	0.3	2.5/4.4
58052-103-ZZ	VZZ-01x02-130/XXX-30A	1300 +/- 20	30 +/- 3	0.2	1.8/5.6
58052-104-ZZ	VZZ-01x02-130/XXX-25A	1300 +/- 20	25 +/- 2	0.2	1.5/6.5
58052-105-ZZ	VZZ-01x02-130/XXX-20A	1300 +/- 20	20 +/- 2	0.2	1.1/7.4
58052-106-ZZ	VZZ-01x02-130/XXX-10A	1300 +/- 20	10 +/- 1	0.2	0.6/11.0
58052-107-ZZ	VZZ-01x02-130/XXX-05A	1300 +/- 20	5 +/- 1	0.2	0.4/14.2
58052-108-ZZ	VZZ-01x02-130/XXX-02A	1300 +/- 20	2 +/- 0.5	0.2	0.3/18.4
58052-109-ZZ	VZZ-01x02-130/XXX-01A	1300 +/- 20	1 +/- 0.2	0.2	0.2/22.0
58052-110-ZZ	VZZ-01x02-131/XXX-50A	1310 +/- 20	50 +/- 3	0.3	3.6
58052-111-ZZ	VZZ-01x02-131/XXX-40A	1310 +/- 20	40 +/- 3	0.3	2.5/4.4
58052-112-ZZ	VZZ-01x02-131/XXX-30A	1310 +/- 20	30 +/- 3	0.2	1.8/5.6
58052-113-ZZ	VZZ-01x02-131/XXX-25A	1310 +/- 20	25 +/- 2	0.2	1.5/6.5
58052-114-ZZ	VZZ-01x02-131/XXX-20A	1310 +/- 20	20 +/- 2	0.2	1.1/7.4
58052-115-ZZ	VZZ-01x02-131/XXX-10A	1310 +/- 20	10 +/- 1	0.2	0.6/11.0
58052-116-ZZ	VZZ-01x02-131/XXX-05A	1310 +/- 20	5 +/- 1	0.2	0.4/14.2
58052-117-ZZ	VZZ-01x02-131/XXX-02A	1310 +/- 20	2 +/- 0.5	0.2	0.3/18.4
58052-118-ZZ	VZZ-01x02-131/XXX-01A	1310 +/- 20	1 +/- 0.2	0.2	0.2/22.0
58052-119-ZZ	VZZ-01x02-155/XXX-50A	1550 +/- 20	50 +/- 3	0.3	3.6
58052-120-ZZ	VZZ-01x02-155/XXX-40A	1550 +/- 20	40 +/- 3	0.3	2.5/4.4
58052-121-ZZ	VZZ-01x02-155/XXX-30A	1550 +/- 20	30 +/- 3	0.2	1.8/5.6
58052-122-ZZ	VZZ-01x02-155/XXX-25A	1550 +/- 20	25 +/- 2	0.2	1.5/6.5
58052-123-ZZ	VZZ-01x02-155/XXX-20A	1550 +/- 20	20 +/- 2	0.2	1.1/7.4
58052-124-ZZ	VZZ-01x02-155/XXX-10A	1550 +/- 20	10 +/- 1	0.2	0.6/11.0
58052-125-ZZ	VZZ-01x02-155/XXX-05A	1550 +/- 20	5 +/- 1	0.2	0.4/14.2
58052-126-ZZ	VZZ-01x02-155/XXX-02A	1550 +/- 20	2 +/- .5	0.2	0.3/18.4
58052-127-ZZ	VZZ-01x02-155/XXX-01A	1550 +/- 20	1 +/- .2	0.2	0.2/22.0
<b>Dual Window Couplers</b>					
58052-201-ZZ	DZZ-01x02-130/155-50A	1300/1550 +/- 20	50 +/- 5	0.5	3.8
58052-202-ZZ	DZZ-01x02-130/155-40A	1300/1550 +/- 20	40 +/- 4	0.3	2.5/4.5
58052-203-ZZ	DZZ-01x02-130/155-20A	1300/1550 +/- 20	20 +/- 2	0.2	1.2/7.4
58052-204-ZZ	DZZ-01x02-130/155-10A	1300/1550 +/- 20	10 +/- 2	0.2	0.7/11.3
58052-205-ZZ	DZZ-01x02-131/155-50A	1310/1550 +/- 20	50 +/- 5	0.5	3.8
58052-206-ZZ	DZZ-01x02-131/155-40A	1310/1550 +/- 20	40 +/- 4	0.3	2.5/4.5
58052-207-ZZ	DZZ-01x02-131/155-30A	1310/1550 +/- 20	30 +/- 3	0.3	2.0/6.0
58052-208-ZZ	DZZ-01x02-131/155-20A	1310/1550 +/- 20	20 +/- 2	0.2	1.2/7.4
58052-209-ZZ	DZZ-01x02-131/155-10A	1310/1550 +/- 20	10 +/- 2	0.2	0.7/11.3
58052-210-ZZ	DZZ-01x02-131/155-02A	1310/1550 +/- 20	2 +/- 0.5	0.2	0.3/19.0
58052-211-ZZ	DZZ-01x02-131/155-01A	1310/1550 +/- 20	1 +/- 0.2	0.2	0.3/22.0

- Notes:  
 1. The -ZZ at the end of the part Number specifies the housing and leads. Use type "BS", "FL", or "RP" designators.  
 2. Specifications are the same for type "BS", "FL", and "RP" housings and leads



## Specifications for Standard Singlemode 2x2 Couplers

Coupling:	Please refer to the following table.	
Optical Fiber(s):	SMF28™ (except single wavelength couplers use HI780™ or HI1060™)	
Directivity:	≥ 50dB	
Thermal Sensitivity:	≤ +/- 0.2 dB (-40 to +85°C)	
Dimensions:	Please refer to drawings on previous page.	
Standard Lead Lengths:	BS-type (250µm coating)	Lead length (nom) = 1m
	FL-type (0.9mm TFE tube)	Lead length (nom) = 55cm
	RP-type (2.5mm Reinforced Jacket)	Lead length (nom) = 55cm

SMF28™, HI780™, and HI1060™ are registered trademarks of Corning Inc.  
 \* Optional lead lengths are available. Consult factory for leadlength options and information

Part Number (see note 1)	Part Descriptor	Wavelength (nm)	Coupling Ratio (%)	Maximum Excess Loss (db)	Maximum Insertion Loss (db)
<b>Single Wavelength Couplers</b>					
58077-001-ZZ	CZZ-02x02-085/XXX-50B	850	50 +/- 5	0.5	4.0
58077-002-ZZ	CZZ-02x02-098/XXX-50C	980	50 +/- 5	0.5	4.0
<b>Single Window Couplers</b>					
58077-101-ZZ	VZZ-02x02-130/XXX-50A	1300 +/- 20	50 +/- 3	0.3	3.6
58077-102-ZZ	VZZ-02x02-130/XXX-40A	1300 +/- 20	40 +/- 3	0.3	2.5/4.4
58077-103-ZZ	VZZ-02x02-130/XXX-30A	1300 +/- 20	30 +/- 3	0.2	1.8/5.6
58077-104-ZZ	VZZ-02x02-130/XXX-25A	1300 +/- 20	25 +/- 2	0.2	1.5/6.5
58077-105-ZZ	VZZ-02x02-130/XXX-20A	1300 +/- 20	20 +/- 2	0.2	1.1/7.4
58077-106-ZZ	VZZ-02x02-130/XXX-10A	1300 +/- 20	10 +/- 1	0.2	0.6/11.0
58077-107-ZZ	VZZ-02x02-130/XXX-05A	1300 +/- 20	5 +/- 1	0.2	0.4/14.2
58077-108-ZZ	VZZ-02x02-130/XXX-02A	1300 +/- 20	2 +/- 0.5	0.2	0.3/18.4
58077-109-ZZ	VZZ-02x02-130/XXX-01A	1300 +/- 20	1 +/- 0.2	0.2	0.2/22.0
58077-110-ZZ	VZZ-02x02-131/XXX-50A	1310 +/- 20	50 +/- 3	0.3	3.6
58077-111-ZZ	VZZ-02x02-131/XXX-40A	1310 +/- 20	40 +/- 3	0.3	2.5/4.4
58077-112-ZZ	VZZ-02x02-131/XXX-30A	1310 +/- 20	30 +/- 3	0.2	1.8/5.6
58077-113-ZZ	VZZ-02x02-131/XXX-25A	1310 +/- 20	25 +/- 2	0.2	1.5/6.5
58077-114-ZZ	VZZ-02x02-131/XXX-20A	1310 +/- 20	20 +/- 2	0.2	1.1/7.4
58077-115-ZZ	VZZ-02x02-131/XXX-10A	1310 +/- 20	10 +/- 1	0.2	0.6/11.0
58077-116-ZZ	VZZ-02x02-131/XXX-05A	1310 +/- 20	5 +/- 1	0.2	0.4/14.2
58077-117-ZZ	VZZ-02x02-131/XXX-02A	1310 +/- 20	2 +/- 0.5	0.2	0.3/18.4
58077-118-ZZ	VZZ-02x02-131/XXX-01A	1310 +/- 20	1 +/- 0.2	0.2	0.2/22.0
58077-119-ZZ	VZZ-02x02-155/XXX-50A	1550 +/- 20	50 +/- 3	0.3	3.6
58077-120-ZZ	VZZ-02x02-155/XXX-40A	1550 +/- 20	40 +/- 3	0.3	2.5/4.4
58077-121-ZZ	VZZ-02x02-155/XXX-30A	1550 +/- 20	30 +/- 3	0.2	1.8/5.6
58077-122-ZZ	VZZ-02x02-155/XXX-25A	1550 +/- 20	25 +/- 2	0.2	1.5/6.5
58077-123-ZZ	VZZ-02x02-155/XXX-20A	1550 +/- 20	20 +/- 2	0.2	1.1/7.4
58077-124-ZZ	VZZ-02x02-155/XXX-10A	1550 +/- 20	10 +/- 1	0.2	0.6/11.0
58077-125-ZZ	VZZ-02x02-155/XXX-05A	1550 +/- 20	5 +/- 1	0.2	0.4/14.2
58077-126-ZZ	VZZ-02x02-155/XXX-02A	1550 +/- 20	2 +/- 0.5	0.2	0.3/18.4
58077-127-ZZ	VZZ-02x02-155/XXX-01A	1550 +/- 20	1 +/- 0.2	0.2	0.2/22.0
<b>Dual Window Couplers</b>					
58077-201-ZZ	DZZ-02x02-130/155-50A	1300/1550 +/- 20	50 +/- 5	0.5	3.8
58077-202-ZZ	DZZ-02x02-130/155-40A	1300/1550 +/- 20	40 +/- 4	0.3	2.5/4.5
58077-203-ZZ	DZZ-02x02-130/155-20A	1300/1550 +/- 20	20 +/- 2	0.2	1.2/7.4
58077-204-ZZ	DZZ-02x02-130/155-10A	1300/1550 +/- 20	10 +/- 2	0.2	0.7/11.3
58077-205-ZZ	DZZ-02x02-131/155-50A	1310/1550 +/- 20	50 +/- 5	0.5	3.8
58077-206-ZZ	DZZ-02x02-131/155-40A	1310/1550 +/- 20	40 +/- 4	0.3	2.5/4.5
58077-207-ZZ	DZZ-02x02-131/155-30A	1310/1550 +/- 20	30 +/- 3	0.3	2.0/6.0
58077-208-ZZ	DZZ-02x02-131/155-20A	1310/1550 +/- 20	20 +/- 2	0.2	1.2/7.4
58077-209-ZZ	DZZ-02x02-131/155-10A	1310/1550 +/- 20	10 +/- 2	0.2	0.7/11.3
58077-210-ZZ	DZZ-02x02-131/155-02A	1310/1550 +/- 20	2 +/- 0.5	0.2	0.3/19.0
58077-211-ZZ	DZZ-02x02-131/155-01A	1310/1550 +/- 20	1 +/- 0.2	0.2	0.3/22.0

- Notes:  
 1. The -ZZ at the end of the part Number specifies the housing and leads. Use type "BS", "FL", or "RP" designators.  
 2. Specifications are the same for type "BS", "FL", and "RP" housings and leads



### Ordering Information for Nonstandard Singlemode 1x2 and 2x2 Couplers

□□□-□□x□□-□□□/□□□-□□-□-□.□/□.□-□□-□□

Single wavelength couplers	C
Single window couplers	V
Dual window couplers	D

Steel tube / bare fiber leads	BS
Steel tube / TFE tubing leads	FL
Plastic housing / reinforced jacket leads	RP

1 input	01
2 inputs	02

2 outputs	02
-----------	----

850 nm wavelength	085
980 nm wavelength	098
1300 nm wavelength	130
1310 nm wavelength	131
1550 nm wavelength	155

No secondary wavelength	XXX
1550 nm secondary wavelength	155

Tap ratio	
1% to 50% expressed as 01 to 50	01
	-
	50

SMF-28™	A
HI780	B
HI1060	C

Input lead length	
0.2 m to maximum lead length	0.2
	-
	1.0

Output lead length	
0.2 m to maximum lead length	0.2
	-
	1.0

See page 29 for ordering information on optional connectors.

## Fiber Optic Singlemode Couplers 1x2 Wideband Couplers

Canstar 1x2 singlemode Wideband Couplers are designed for use in test equipment and optical networks where tighter specification control is required over a broader spectrum. The couplers are insensitive to operating wavelengths over an 80nm wavelength range at 1310 or 1550 nm window. Optimum performance and operation under adverse environmental conditions are achieved through licensed use of fused biconical taper coupler patents, with proprietary refinements combined with rigorous quality control.

### Features and Benefits

- Low insertion loss.
- High directivity.
- Bidirectional.
- Range of coupling ratios.
- Dual window versions available.
- Stable over wide temperature range.
- Range of housing options.
- Optional connectorized leads.
- PC board mountable.

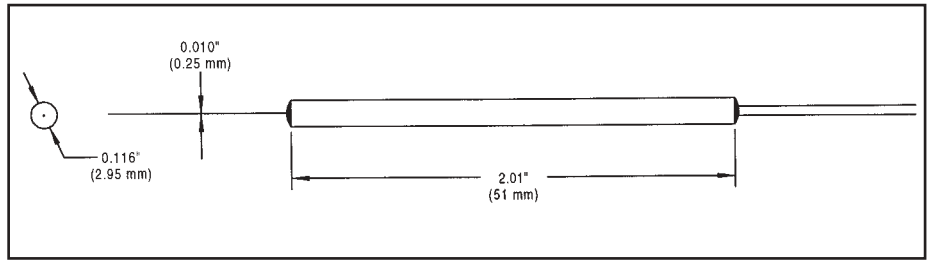

BS - type, 250  $\mu$ m coated fiber leads for most compact size.

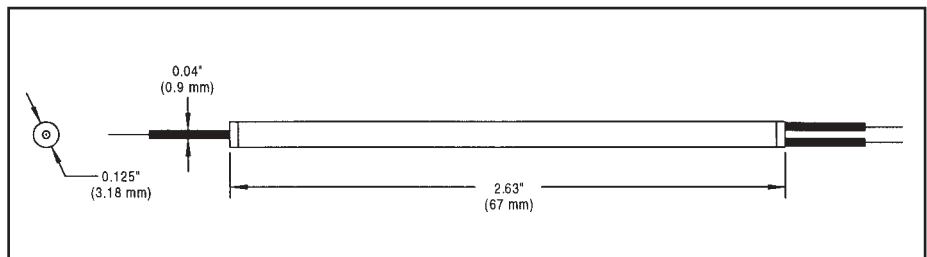

FL - type, 900  $\mu$ m buffer tube leads for added protection.

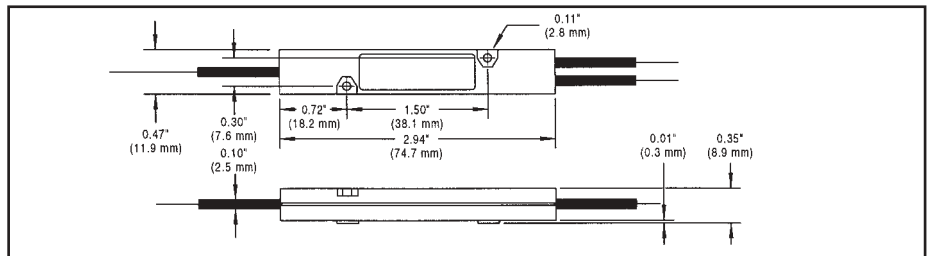

RP - type, 2.5 mm reinforced jacket for rugged use.





## Specifications for Standard Singlemode 1x2 Wideband Couplers

Coupling:	Please refer to the following table.	
Optical Fiber(s):	SMF28™	
Directivity:	≥ 55dB	
Thermal Sensitivity:	≤ +/- 0.2 dB (-40 to +85°C)	
Dimensions:	Please refer to drawings on previous page.	
Standard Lead Lengths:	BS-type (250µm coating)	Lead length (nom) = 1m
	FL-type (0.9mm TFE tube)	Lead length (nom) = 55cm
	RP-type (2.5mm Reinforced Jacket)	Lead length (nom) = 55cm

SMF28™ is a registered trademark of Corning Inc.

\* Optional lead lengths are available. Consult factory for leadlength options and information

Part Number (see note 1)	Part Descriptor	Wavelength (nm)	Coupling Ratio (%)	Maximum Excess Loss (dB)	Maximum Insertion Loss (dB)	Spectral Flatness (Signal/Tap) (+/- dB)
<b>Single Window Couplers</b>						
10007314-101-ZZ	NZZ-01x02-155/XXX-05A	1550 ± 40	5 +/- 1.0	0.15	0.4/14.5	0.05/0.1
10007314-102-ZZ	NZZ-01x02-155/XXX-01A	1550 ± 40	1 +/- 0.5	0.15	0.25/21.5	0.05/0.1
<b>Dual Window Couplers</b>						
10007314-201-ZZ	UZZ-01x02-131/155-01A	1310/1550 +/- 40	1 +/- 0.5	0.15	0.3/22.0	0.2/0.3

Notes:

1. The -ZZ at the end of the part Number specifies the housing and leads. Use type "BS", "FL", or "RP" designators.
2. Specifications are the same for type "BS", "FL", and "RP" housings and leads
3. Consult factory for other coupling ratios.

### Ordering Information for Nonstandard Singlemode 1x2 Wideband Couplers

□□□-□□x□□-□□□/□□□-□□-□-□.□/□.□-□□-□□

Single window couplers	N
Dual window couplers	U
Steel tube / bare fiber leads	BS
Steel tube / TFE tubing leads	FL
Plastic housing / reinforced jacket leads	RP
1 input	01
2 outputs	02
1310 nm wavelength	131
1550 nm wavelength	155
No secondary wavelength	XXX
1550 nm secondary wavelength	155
Tap ratio	
1% to 50% expressed as 01 to 50	01
	-
	50
SMF-28™	A
Input lead length	
0.2 m to maximum lead length	0.2
	-
	1.0
Output lead length	
0.2 m to maximum lead length	0.2
	-
	1.0

See page 29 for ordering information on optional connectors.

## Fiber Optic Singlemode Couplers 1x3 and 1x4 Couplers

Canstar 1x3 and 1x4 Couplers are designed for use in test equipment and optical networks. Optimum performance and operation under adverse environmental conditions are achieved through licensed use of fused biconical taper coupler patents, with proprietary refinements combined with rigorous quality control.

### Features and Benefits

- Single fusion compactness & reliability.
- Low insertion loss.
- High directivity.
- Bidirectional.
- Uniform outputs.
- Wide band and dual window.
- Stable over wide temperature range.
- Compact housing.
- Optional connectorized leads.

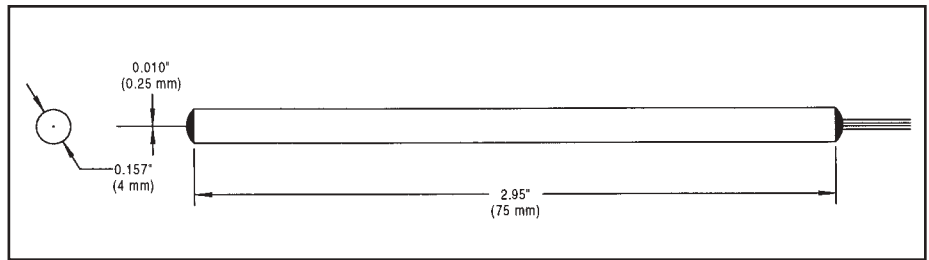

DS - type, 250  $\mu$ m coated fiber leads.

Photographs and drawings shown depicts 1x3 Couplers. The same dimensions apply for 1x4 Couplers.

### Specifications for Standard Singlemode 1x3 and 1x4 Couplers

Coupling:	Please refer to the following table.	
Optical Fiber(s):	SMF28™	
Directivity:	$\geq 50$ dB	
Thermal Sensitivity:	$\leq \pm 0.2$ dB (-40 to +85°C)	
Dimensions:	Please refer to above drawings.	
Standard Lead Lengths:	DS-type (250 $\mu$ m coating)	Lead length (nom) = 1m

SMF28™ is a registered trademark of Corning Inc.  
\* Optional lead lengths are available. Consult factory for leadlength options and information

### Singlemode 1x3 Standard Products

Part Number	Part Descriptor	Wavelength (nm)	Coupling Ratio (%)	Maximum Excess Loss (dB)	Maximum Uniformity (dB)	Maximum Insertion Loss (dB)	Input Lead Length (m)	Output Lead Length (m)
<b>Single Window Couplers</b>								
58063-101-DS	VDS-01x03-130/XXX-33A	1300 +/- 20	33 +/- 3	0.5	1.0	6.0	1.0	1.0
58063-102-DS	VDS-01x03-131/XXX-33A	1310 +/- 20	33 +/- 3	0.5	1.0	6.0	1.0	1.0
58063-103-DS	VDS-01x03-155/XXX-33A	1550 +/- 20	33 +/- 3	0.5	1.0	6.0	1.0	1.0
<b>Dual Window Couplers</b>								
58063-201-DS	DDS-01x03-130/155-33A	1300/1550 +/- 20	33 +/- 3	0.5	1.0	6.0	1.0	1.0
58063-202-DS	DDS-01x03-131/155-33A	1310/1550 +/- 20	33 +/- 3	0.5	1.0	6.0	1.0	1.0

### Singlemode 1x4 Standard Products

Part Number	Part Descriptor	Wavelength (nm)	Coupling Ratio (%)	Maximum Excess Loss (dB)	Maximum Uniformity (dB)	Maximum Insertion Loss (dB)	Input Lead Length (m)	Output Lead Length (m)
<b>Single Window Couplers</b>								
58053-101-DS	VDS-01x04-130/XXX-25A	1300 +/- 20	25 +/- 4	0.5	1.5	7.5	1.0	1.0
58053-102-DS	VDS-01x04-131/XXX-25A	1310 +/- 20	25 +/- 4	0.5	1.5	7.5	1.0	1.0
58053-103-DS	VDS-01x04-155/XXX-25A	1550 +/- 20	25 +/- 4	0.5	1.5	7.5	1.0	1.0
<b>Dual Window Couplers</b>								
58053-201-DS	DDS-01x04-130/155-25A	1300/1550 +/- 20	25 +/- 4	0.5	1.5	7.5	1.0	1.0
58053-202-DS	DDS-01x04-131/155-25A	1310/1550 +/- 20	25 +/- 4	0.5	1.5	7.5	1.0	1.0

### Ordering Information for Nonstandard Singlemode 1x3 and 1x4 Couplers

□□□-□□x□□-□□□/□□□-□□-□-□.□/□.□-□□-□□

Single window 1x3, 1x4	V
Dual window 1x3, 1x4	D
Steel tube / bare fiber leads	DS
1 input	01
3 outputs	03
4 outputs	04
1300 nm wavelength	130
1310 nm wavelength	131
1550 nm wavelength	155
No secondary wavelength	XXX
1550 nm secondary wavelength	155
Nominal even power split 1x3	33
Nominal even power split 1x4	25
SMF-28™	A
Input lead length *	
0.2 m to maximum lead length	0.2
	-
	1.0
Output lead length *	
0.2 m to maximum lead length	0.2
	-
	1.0

See page 29 for ordering information on optional connectors.

\* Optional lead lengths available. Consult factory for lead length options and information.

## Fiber Optic Singlemode Couplers 1xN and 2xN Concatenated Couplers

Canstar 1xN and 2xN concatenated couplers are designed for use in optical networks. Optimum performance and operation under adverse environmental conditions are achieved through licensed use of fused biconical taper coupler patents, with proprietary refinements combined with rigorous quality control.

### Features and Benefits

- Low insertion loss.
- High directivity.
- Bidirectional.
- Uniform outputs.
- Non-standard port counts and output distribution available.
- Dual window versions available.
- Stable over wide temperature range.
- Range of housing options.
- PC board mountable.
- Non-metallic.
- Optional connectorized leads.

Photographs and drawings shown depict 1xN Concatenated Couplers. The same dimensions apply for 2xN Concatenated Couplers.

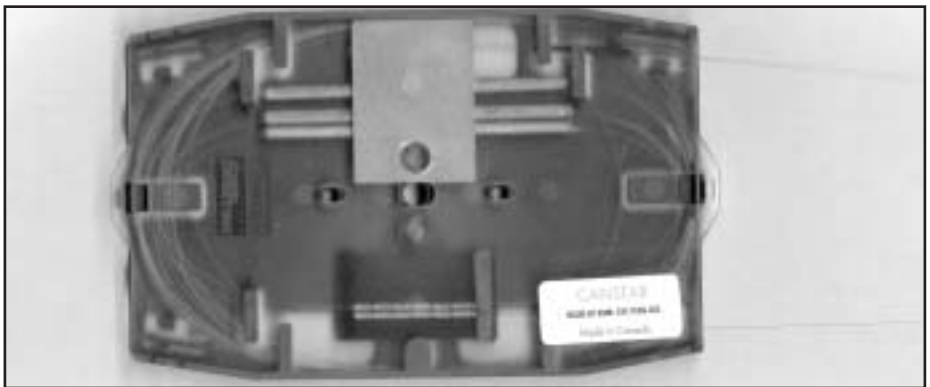
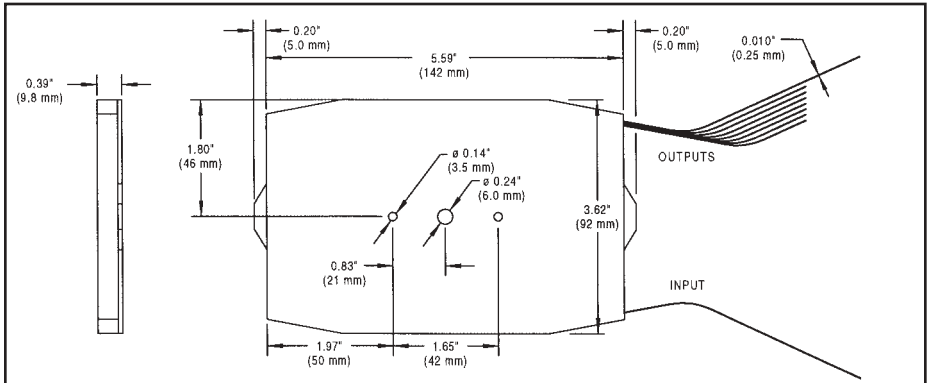

GS - type, 250  $\mu$ m coated fiber leads.

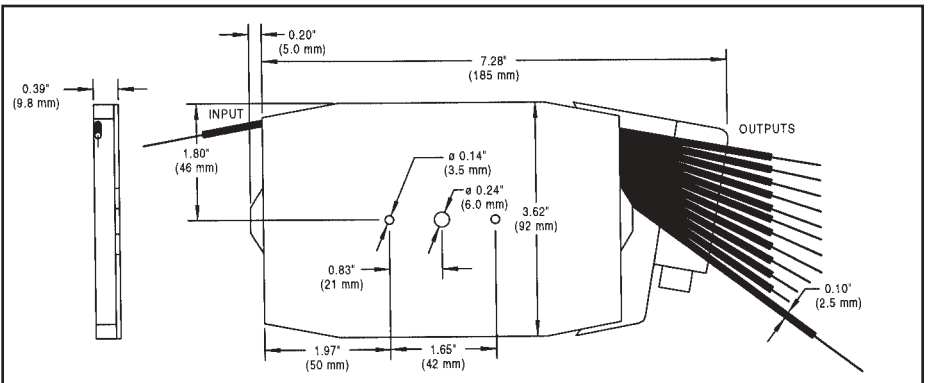

GP - type, 2.5 mm reinforced jacket leads.



## Specifications for Standard Singlemode 1xN Concatenated Couplers

Coupling:	Please refer to the following table.	
Optical Fiber(s):	SMF28™	
Directivity:	≥ 50dB	
Temperature Range:	-20 to +70°C	
Standard Lead Lengths:	GS-type (250µm coating)	Lead length (nom) beyond cassette = 1m
	GL-type (0.9mm TFE tube)	Lead length (nom) beyond cassette = 55cm
	GP-type (2.5mm Reinforced Jacket)	Lead length (nom) beyond cassette = 55cm

SMF28™ is a registered trademark of Corning Inc.

\* Optional lead lengths are available. Consult factory for leadlength options and information

Part Number (see note 1)	Part Descriptor	Wavelength (nm)	Maximum Insertion Loss (dB)	Maximum Uniformity (dB)	Thermal Sensitivity (dB)
<b>Single Window Couplers</b>					
10003293-001-ZZ	GZZ-01x04-130/XXX-YYA	1300 +/- 20	7.5	1.5	≤ +/- 0.2
10003293-002-ZZ	GZZ-01x08-130/XXX-YYA	1300 +/- 20	11.5	2.0	≤ +/- 0.4
10003293-003-ZZ	GZZ-01x16-130/XXX-YYA	1300 +/- 20	15.0	2.5	≤ +/- 0.4
10003293-004-ZZ	GZZ-01x04-131/XXX-YYA	1310 +/- 20	7.5	1.5	≤ +/- 0.2
10003293-005-ZZ	GZZ-01x08-131/XXX-YYA	1310 +/- 20	11.5	2.0	≤ +/- 0.4
10003293-006-ZZ	GZZ-01x16-131/XXX-YYA	1310 +/- 20	15.0	2.5	≤ +/- 0.4
10003293-007-ZZ	GZZ-01x04-155/XXX-YYA	1550 +/- 20	7.5	1.5	≤ +/- 0.2
10003293-008-ZZ	GZZ-01x08-155/XXX-YYA	1550 +/- 20	11.5	2.0	≤ +/- 0.4
10003293-009-ZZ	GZZ-01x16-155/XXX-YYA	1550 +/- 20	15.0	2.5	≤ +/- 0.4
<b>Dual Window Couplers</b>					
10003293-010-ZZ	SZZ-01x04-130/155-YYA	1300/1550 +/- 20	7.5	1.5	≤ +/- 0.2
10003293-011-ZZ	SZZ-01x08-130/155-YYA	1300/1550 +/- 20	11.5	2.0	≤ +/- 0.4
10003293-012-ZZ	SZZ-01x16-130/155-YYA	1300/1550 +/- 20	15.0	2.5	≤ +/- 0.4
10003293-013-ZZ	SZZ-01x04-131/155-YYA	1310/1550 +/- 20	7.5	1.5	≤ +/- 0.2
10003293-014-ZZ	SZZ-01x08-131/155-YYA	1310/1550 +/- 20	11.5	2.0	≤ +/- 0.4
10003293-015-ZZ	SZZ-01x16-131/155-YYA	1310/1550 +/- 20	15.0	2.5	≤ +/- 0.4

**Notes:**

1. The -ZZ at the end of the part Number specifies the housing and leads. Use type "GS", "GL", or "GP" designators.
2. The number of output ports is not limited to 4, 8, 16. Please contact factory for low loss custom couplers with N = 3, 5, 6, 7, 9, 10, 12, 14, 15, 18, and 20.
3. All Concatenated Couplers have a nominal even power split. For uneven power split, please contact factory.



## Specifications for Standard Singlemode 2xN Concatenated Couplers

Coupling:	Please refer to the following table.	
Optical Fiber(s):	SMF28™	
Directivity:	≥ 50dB	
Temperature Range:	-20 to +70°C	
Standard Lead Lengths:	GS-type (250µm coating)	Lead length (nom) beyond cassette = 1m
	GL-type (0.9mm TFE tube)	Lead length (nom) beyond cassette = 55cm
	GP-type (2.5mm Reinforced Jacket)	Lead length (nom) beyond cassette = 55cm

SMF28™ is a registered trademark of Corning Inc.

\* Optional lead lengths are available. Consult factory for leadlength options and information

Part Number (see note 1)	Part Descriptor	Wavelength (nm)	Maximum Insertion Loss (dB)	Maximum Uniformity (dB)	Thermal Sensitivity (dB)
<b>Single Window Couplers</b>					
10004340-001-ZZ	GZZ-02x04-130/XXX-YYA	1300 +/- 20	7.5	1.7	≤ +/- 0.2
10004340-002-ZZ	GZZ-02x08-130/XXX-YYA	1300 +/- 20	11.5	2.2	≤ +/- 0.4
10004340-003-ZZ	GZZ-02x16-130/XXX-YYA	1300 +/- 20	15.0	2.7	≤ +/- 0.4
10004340-004-ZZ	GZZ-02x04-131/XXX-YYA	1310 +/- 20	7.5	1.7	≤ +/- 0.2
10004340-005-ZZ	GZZ-02x08-131/XXX-YYA	1310 +/- 20	11.5	2.2	≤ +/- 0.4
10004340-006-ZZ	GZZ-02x16-131/XXX-YYA	1310 +/- 20	15.0	2.7	≤ +/- 0.4
10004340-007-ZZ	GZZ-02x04-155/XXX-YYA	1550 +/- 20	7.5	1.7	≤ +/- 0.2
10004340-008-ZZ	GZZ-02x08-155/XXX-YYA	1550 +/- 20	11.5	2.2	≤ +/- 0.4
10004340-009-ZZ	GZZ-02x16-155/XXX-YYA	1550 +/- 20	15.0	2.7	≤ +/- 0.4
<b>Dual Window Couplers</b>					
10004340-010-ZZ	SZZ-02x04-130/155-YYA	1300/1550 +/- 20	7.5	1.7	≤ +/- 0.2
10004340-011-ZZ	SZZ-02x08-130/155-YYA	1300/1550 +/- 20	11.5	2.2	≤ +/- 0.4
10004340-012-ZZ	SZZ-02x16-130/155-YYA	1300/1550 +/- 20	15.0	2.7	≤ +/- 0.4
10004340-013-ZZ	SZZ-02x04-131/155-YYA	1310/1550 +/- 20	7.5	1.7	≤ +/- 0.2
10004340-014-ZZ	SZZ-02x08-131/155-YYA	1310/1550 +/- 20	11.5	2.2	≤ +/- 0.4
10004340-015-ZZ	SZZ-02x16-131/155-YYA	1310/1550 +/- 20	15.0	2.7	≤ +/- 0.4

Notes:

1. The -ZZ at the end of the part Number specifies the housing and leads. Use type "GS", "GL", or "GP" designators.
2. The number of output ports is not limited to 4, 8, 16. Please contact factory for low loss custom couplers with N = 3, 5, 6, 7, 9, 10, 12, 14, 15, 18, and 20.
3. All Concatenated Couplers have a nominal even power split. For uneven power split, please contact factory.

### Ordering Information for Nonstandard Singlemode 1xN and 2xN Concatenated Couplers

□□□-□□×□□-□□□/□□□-□□-□-□.□/□.□-□□-□□

Concatenated single window coupler	G
Concatenated dual window coupler	S
Cassette with bare fiber leads	GS
Cassette with TFE tubed leads	GL
Cassette with reinforced jacket leads	GP
1 input	01
2 inputs	02
Number of outputs	
3 to 20	03
	-
	20
1300 nm wavelength	130
1310 nm wavelength	131
1550 nm wavelength	155
No secondary wavelength	XXX
1550 nm secondary wavelength	155
Nominal even power split	YY
SMF-28™	A
Input lead length	
0.2 m to maximum lead length	0.2
	-
	1.0
Output lead length	
0.2 m to maximum lead length	0.2
	-
	1.0

See page 29 for ordering information on optional connectors.

\* Optional lead lengths available. Consult factory for lead length options and information.

## Fiber Optic Singlemode WDMs 1x2 Wavelength Division Multiplexers

Canstar singlemode WDMs are designed for mixing and separating two optical signals in test equipment, fiber optic transmission equipment and systems. 980/1550 nm WDMs are specifically designed for use in EDFA systems. Optimum performance and operation under adverse environmental conditions are achieved through licensed use of fused biconical taper coupler patents, with proprietary refinements combined with rigorous quality control.

### Features and Benefits

- Low insertion loss.
- High directivity.
- Bidirectional.
- High isolation.
- Extended isolation and narrowband versions available.
- Stable over wide temperature range.
- Range of housing options.
- Optional connectorized leads.
- PC board mountable.

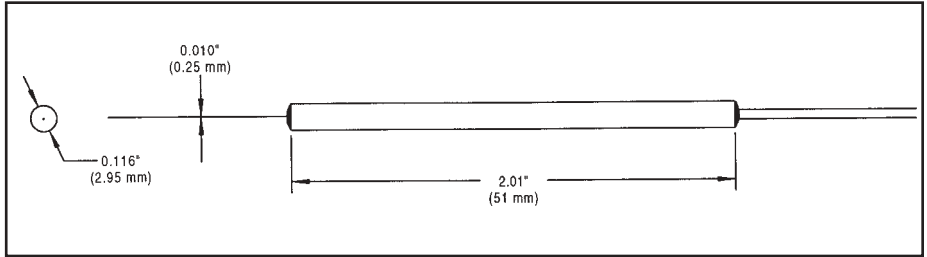

BS - type, 250  $\mu$ m coated fiber leads for most compact size.

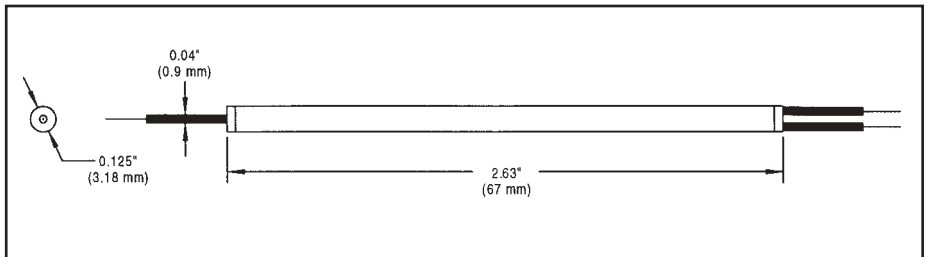

FL - type, 900  $\mu$ m buffer tube leads for added protection.

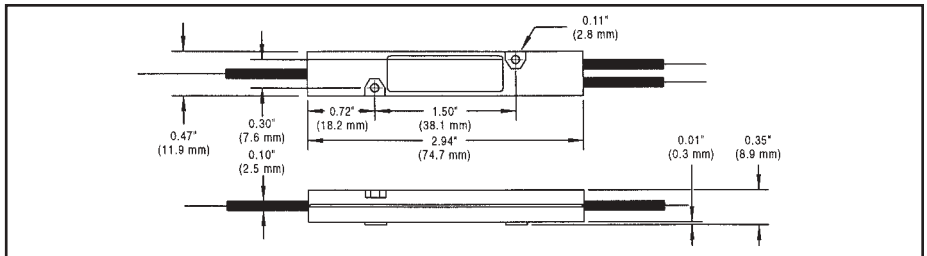

RP - type, 2.5 mm reinforced jacket for rugged use.



## Specifications for Standard 1x2 Wavelength Division Multiplexers

Coupling:	Please refer to the following table.	
Optical Fiber(s):	SMF28™	
Temperature Range:	-40 to +85°C	
Dimensions:	Please refer to drawings on previous page.	
Standard Lead Lengths:	BS-type (250µm coating)	Lead length (nom) = 1m
	FL-type (0.9mm TFE tube)	Lead length (nom) = 55cm
	RP-type (2.5mm Reinforced Jacket)	Lead length (nom) = 55cm

SMF28™ is a registered trademark of Corning Inc.  
 \* Optional lead lengths are available. Consult factory for leadlength options and information

Part Number (see note 1)	Part Descriptor	Wavelength (nm)	Isolation (db)	Maximum Excess Loss (db)	Directivity (db)	Thermal Sensitivity (db)
58060-201-ZZ	WZZ-01x02-098/155-XXA	980/1550 +/- 20	≥ 20 <sup>Note 2</sup>	0.3	≥ 50	≤ +/- 0.2
58060-202-ZZ	WZZ-01x02-130/155-XXA	1300/1550 +/- 20	≥ 15	0.5	≥ 60	≤ +/- 0.2
58060-203-ZZ	WZZ-01x02-131/155-XXA	1310/1550 +/- 20	≥ 15	0.5	≥ 60	≤ +/- 0.2
58060-204-ZZ	WZZ-01x02-148/155-XXA	1480/1550 +/- 20	≥ 10	1.0	≥ 50	≤ +/- 0.2

- Notes:
- The -ZZ at the end of the part Number specifies the housing and leads. Use type "BS", "FL", or "RP" designators.
  - Isolation at 980 nm is LP<sub>11</sub> filtered input
  - Specifications are the same for type "BS", "FL", and "RP" housings and leads.

## Ordering Information for Nonstandard Wavelength Division Multiplexers

□□□-□□x□□-□□□/□□□-□□-□-□.□/□.□-□□-□□

WDM	W
Steel tube / bare fiber leads	BS
Steel tube / TFE tubed leads	FL
Plastic housing / reinforced jacket leads	RP
1 input	01
2 outputs	02
980 nm wavelength	098
1300 nm wavelength	130
1310 nm wavelength	131
1480 nm wavelength	148
1550 nm secondary wavelength	155
Power split N/A	XX
SMF-28™	A
Input lead length	
0.2 m to maximum lead length	0.2
	-
	1.0
Output lead length	
0.2 m to maximum lead length	0.2
	-
	1.0

See page 29 for ordering information on optional connectors.

## Fiber Optic Singlemode Attenuators

Canstar singlemode in-line Attenuators are designed for minimum backreflection, and low wavelength and polarization sensitivity. They are designed for use in precision fiber optic transmission equipment and optical networks. Optimum performance and operation under adverse environmental conditions are achieved through licensed use of fused biconical taper coupler patents, with proprietary refinements combined with rigorous quality control.

### Features and Benefits

- All fiber design.
- Accurate insertion loss.
- Very low backreflection.
- Bidirectional.
- Polarization insensitive.
- Stable over wide temperature range.
- Range of housing options.
- Optional connectorized leads.

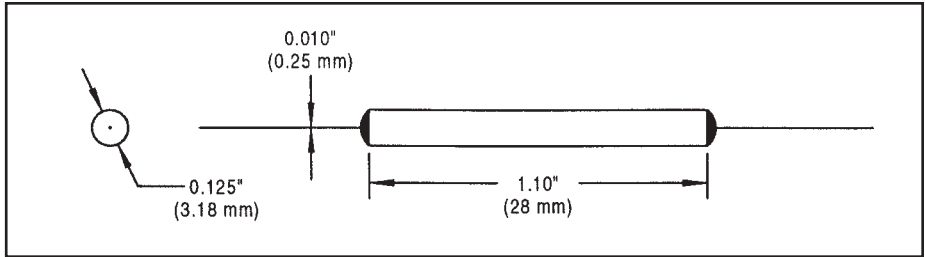

AS - type, 250  $\mu$ m coated fiber leads for most compact size.

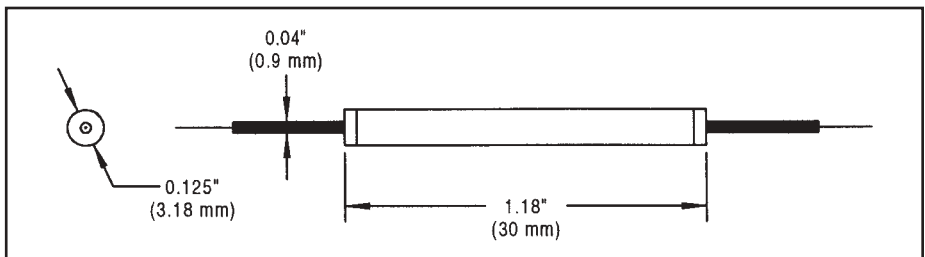

EL - type, 900  $\mu$ m buffer tube leads for added protection.

## Specifications for Standard Singlemode Attenuators

Insertion Loss:	Please refer to the following table.	
Optical Fiber(s):	SMF 28™	
Directivity:	≥ 60 dB (without connectors)	
Thermal Sensitivity:	10% of nominal attenuation (-40 to +85 °C)	
Dimensions:	Please refer to drawings on previous page.	
Standard Lead Lengths:	AS-type (250µm coating)	Lead length (nom) = 1m
	EL-type (0.9mm TFE tube)	lead length (nom) = 55cm

SMF28™ is a registered trademark of Corning Inc.

\* Optional lead lengths are available. Consult factory for leadlength options and information

Part Number	Part Descriptor	Wavelength (nm)	Attenuation (db)
10003294-001-AS	AAS-01x01-131/155-20A	1310/1550 +/- 20	20 +/- 2.0
10003294-002-AS	AAS-01x01-131/155-15A	1310/1550 +/- 20	15 +/- 1.5
10003294-003-AS	AAS-01x01-131/155-10A	1310/1550 +/- 20	10 +/- 1.0
10003294-004-AS	AAS-01x01-131/155-05A	1310/1550 +/- 20	5 +/- 0.5
10003294-001-EL	AEL-01x01-131/155-20A	1310/1550 +/- 20	20 +/- 2.0
10003294-002-EL	AEL-01x01-131/155-15A	1310/1550 +/- 20	15 +/- 1.5
10003294-003-EL	AEL-01x01-131/155-10A	1310/1550 +/- 20	10 +/- 1.0
10003294-004-EL	AEL-01x01-131/155-05A	1310/1550 +/- 20	5 +/- 0.5

## Ordering Information for Nonstandard Singlemode Attenuators

□□□-□□x□□-□□□/□□□-□□-□-□.□/□.□-□□-□□

Attenuator	A
Steel tube / bare fiber leads	AS
Steel tube / TFE tubed leads	EL
1 input	01
1 output	01
1310 nm wavelength	131
1550 nm secondary wavelength	155
Attenuator insertion loss (dB)	
5, 10, 15, 20	05
	-
	20
SMF-28™	A
Input lead length	
0.2 m to maximum lead length	0.2
	-
	1.0
Output lead length	
0.2 m to maximum lead length	0.2
	-
	1.0

See page 29 for ordering information on optional connectors.



## Fiber Optic Multimode Couplers

### 1x2 and 2x2 Couplers

Canstar 1x2 and 2x2 multimode couplers are designed for use in test equipment as well as data communications and industrial fiber optic networks. Optimum performance and operation under adverse environmental conditions are achieved through licensed use of fused biconical taper coupler patents, with proprietary refinements combined with rigorous quality control.

### Features and Benefits

- Low insertion loss.
- High directivity.
- Bidirectional.
- Range of fiber sizes.
- Range of tap ratios.
- Stable over wide temperature range.
- Range of housing options.
- Optional connectorized leads.
- PC board mountable.

Photographs and drawings shown depict 1x2 Couplers. The same dimensions apply for 2x2 Couplers.

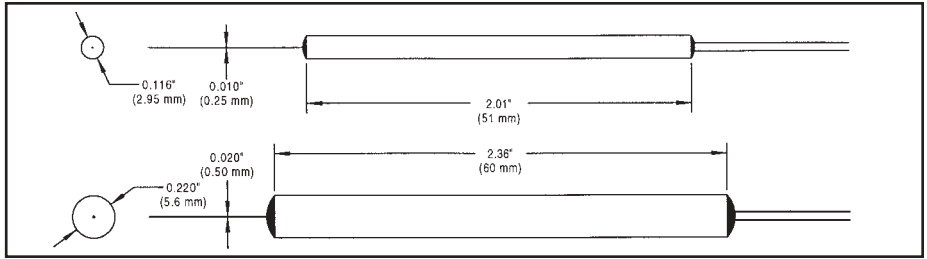

BS - type, 250 μm coated fiber leads for the most compact size.  
MQ - type, 250 μm coated fiber leads.

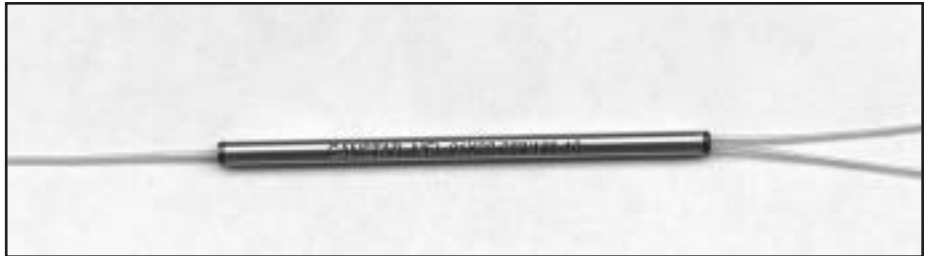
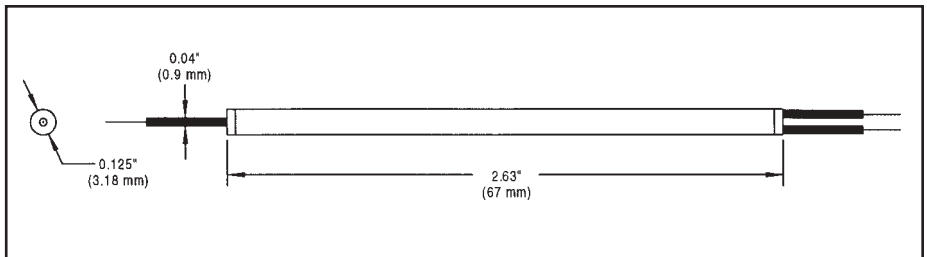

FL - type, 900 μm buffer type leads for added protection.

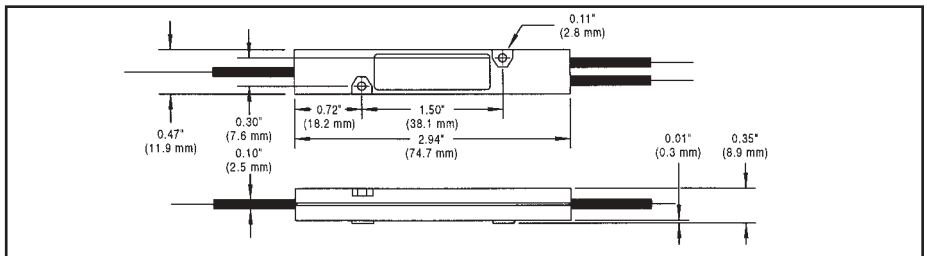

RP - type, 2.5 mm reinforced jacket for rugged use.



## Specifications for Standard Multimode 1x2 Couplers

Coupling:	Please refer to the following table. Couplers are tested under fully filled launch conditions.		
Optical Fiber(s):	Corning™ and Spectran™ acrylate coated, glass clad fibers 50/125/250, 62.5/125/250, 100/140/250, and 200/240/500. Contact factory for other fibers, including step index.		
Wavelength Range:	Designed for operation over 600 to 1600 nm, guaranteed at 850 nm or 1300 nm as specified.		
Directivity:	≥ 40 dB		
Thermal Cycling:	-40 to +85 °C		
Dimensions:	Please refer to drawings on previous page.		
Lead Lengths:	BS-type (250µm coating)	Lead length (nom) = 1m	
	MQ-type (500µm coating)	Lead length (nom) = 1m	
	FL-type (0.9mm TFE tube)	Lead length (nom) = 55cm	
	RP-type (2.5mm Reinforced Jacket)	Lead length (nom) = 55cm	

Corning™ is a registered Trademark of Corning Inc.

Spectran™ is a registered Trademark of Spectran Specialty Optics Company.

Part Number (see Note1)	Part Descriptor	Wavelength (nm)	Coupling Ratio (%)	Maximum Throughport Loss (db)	Minimum Throughport Loss (db)	Maximum Coupledport Loss (db)	Minimum Coupledport Loss (db)
58056-001-ZZ	MZZ-01x02-050/125-50F	850	50 +/-5	4.2	3.0	4.2	3.0
58056-002-ZZ	MZZ-01x02-050/125-40F	850	40 +/-5	3.4	1.9	5.4	3.5
58056-003-ZZ	MZZ-01x02-050/125-30F	850	30 +/-5	2.7	1.3	6.8	4.6
58056-004-ZZ	MZZ-01x02-050/125-20F	850	20 +/-3	1.9	0.9	8.5	6.4
58056-005-ZZ	MZZ-01x02-050/125-10F	850	10 +/-2	1.4	0.4	11.8	9.3
58056-006-ZZ	MZZ-01x02-050/125-05F	850	5 +/-2	1.1	0.2	16.0	11.6
58056-007-ZZ	MZZ-01x02-062/125-50F	850	50 +/-5	4.2	3.0	4.2	3.0
58056-008-ZZ	MZZ-01x02-062/125-40F	850	40 +/-5	3.4	1.9	5.4	3.5
58056-009-ZZ	MZZ-01x02-062/125-30F	850	30 +/-5	2.7	1.3	6.8	4.6
58056-010-ZZ	MZZ-01x02-062/125-20F	850	20 +/-3	1.9	0.9	8.5	6.4
58056-011-ZZ	MZZ-01x02-062/125-10F	850	10 +/-2	1.4	0.4	11.8	9.3
58056-012-ZZ	MZZ-01x02-062/125-05F	850	5 +/-2	1.1	0.2	16.0	11.6
58056-013-ZZ	MZZ-01x02-100/140-50F	850	50 +/-5	4.2	3.0	4.2	3.0
58056-014-ZZ	MZZ-01x02-100/140-40F	850	40 +/-5	3.4	1.9	5.4	3.5
58056-015-ZZ	MZZ-01x02-100/140-30F	850	30 +/-5	2.7	1.3	6.8	4.6
58056-016-ZZ	MZZ-01x02-100/140-20F	850	20 +/-3	1.9	0.9	8.5	6.4
58056-017-ZZ	MZZ-01x02-100/140-10F	850	10 +/-2	1.4	0.4	11.8	9.3
58056-018-ZZ	MZZ-01x02-100/140-05F	850	5 +/-2	1.1	0.2	16.0	11.6
58056-019-MQ	MMQ-01x02-200/240-50F	850	50 +/-5	4.8	3.0	5.1	3.0
58056-020-MQ	MMQ-01x02-200/240-25F	850	25 +/-4	2.8	1.4	8.1	5.7
58056-021-MQ	MMQ-01x02-200/240-06F	850	6 +/-2	1.5	0.2	15.0	11.0
58056-201-ZZ	MZZ-01x02-050/125-50G	1300	50 +/-5	4.2	3.0	4.2	3.0
58056-202-ZZ	MZZ-01x02-050/125-40G	1300	40 +/-5	3.4	1.9	5.4	3.5
58056-203-ZZ	MZZ-01x02-050/125-30G	1300	30 +/-5	2.7	1.3	6.8	4.6
58056-204-ZZ	MZZ-01x02-050/125-20G	1300	20 +/-3	1.9	0.9	8.5	6.4
58056-205-ZZ	MZZ-01x02-050/125-10G	1300	10 +/-2	1.4	0.4	11.8	9.3
58056-206-ZZ	MZZ-01x02-050/125-05G	1300	5 +/-2	1.1	0.2	16.0	11.6
58056-207-ZZ	MZZ-01x02-062/125-50G	1300	50 +/-5	4.2	3.0	4.2	3.0
58056-208-ZZ	MZZ-01x02-062/125-40G	1300	40 +/-5	3.4	1.9	5.4	3.5
58056-209-ZZ	MZZ-01x02-062/125-30G	1300	30 +/-5	2.7	1.3	6.8	4.6
58056-210-ZZ	MZZ-01x02-062/125-20G	1300	20 +/-3	1.9	0.9	8.5	6.4
58056-211-ZZ	MZZ-01x02-062/125-10G	1300	10 +/-2	1.4	0.4	11.8	9.3
58056-212-ZZ	MZZ-01x02-062/125-05G	1300	5 +/-2	1.1	0.2	16.0	11.6
58056-213-ZZ	MZZ-01x02-100/140-50G	1300	50 +/-5	4.2	3.0	4.2	3.0
58056-214-ZZ	MZZ-01x02-100/140-40G	1300	40 +/-5	3.4	1.9	5.4	3.5
58056-215-ZZ	MZZ-01x02-100/140-30G	1300	30 +/-5	2.7	1.3	6.8	4.6
58056-216-ZZ	MZZ-01x02-100/140-20G	1300	20 +/-3	1.9	0.9	8.5	6.4
58056-217-ZZ	MZZ-01x02-100/140-10G	1300	10 +/-2	1.4	0.4	11.8	9.3
58056-218-ZZ	MZZ-01x02-100/140-05G	1300	5 +/-2	1.1	0.2	16.0	11.6

### Notes:

- The -ZZ at the end of the Part Number specifies the Housing and Leads. Use type "BS", "FL", or "RP" designators. The -MQ specifies the -MQ housing and leads.
- Specifications are the same for type "BS", "FL", and "RP" housings and leads



## Specifications for Standard Multimode 2x2 Couplers

Coupling:	Please refer to the following table. Couplers are tested under fully filled launch conditions.		
Optical Fiber(s):	Corning™ and Spectran™ acrylate coated, glass clad fibers 50/125/250, 62.5/125/250, 100/140/250, and 200/240/500. Contact factory for other fibers, including step index.		
Wavelength Range:	Designed for operation over 600 to 1600 nm, guaranteed at 850 nm or 1300 nm as specified.		
Directivity:	≥ 40 dB		
Thermal Cycling:	-40 to +85 °C		
Dimensions:	Please refer to drawings on previous page.		
Lead Lengths:	BS-type (250µm coating)	Lead length (nom) = 1m	
	MQ-type (500µm coating)	Lead length (nom) = 1m	
	FL-type (0.9mm TFE tube)	Lead length (nom) = 55cm	
	RP-type (2.5mm Reinforced Jacket)	Lead length (nom) = 55cm	

Corning™ is a registered Trademark of Corning Inc.

Spectran™ is a registered Trademark of Spectran Specialty Optics Company.

Part Number (see Note1)	Part Descriptor	Wavelength (nm)	Coupling Ratio (%)	Maximum Throughport Loss (dB)	Minimum Throughport Loss (dB)	Maximum Coupledport Loss (dB)	Minimum Coupledport Loss (dB)
58076-001-ZZ	MZZ-02x02-050/125-50F	850	50 +/-5	4.2	3.0	4.2	3.0
58076-002-ZZ	MZZ-02x02-050/125-40F	850	40 +/-5	3.4	1.9	5.4	3.5
58076-003-ZZ	MZZ-02x02-050/125-30F	850	30 +/-5	2.7	1.3	6.8	4.6
58076-004-ZZ	MZZ-02x02-050/125-20F	850	20 +/-3	1.9	0.9	8.5	6.4
58076-005-ZZ	MZZ-02x02-050/125-10F	850	10 +/-2	1.4	0.4	11.8	9.3
58076-006-ZZ	MZZ-02x02-050/125-05F	850	5 +/-2	1.1	0.2	16.0	11.6
58076-007-ZZ	MZZ-02x02-062/125-50F	850	50 +/-5	4.2	3.0	4.2	3.0
58076-008-ZZ	MZZ-02x02-062/125-40F	850	40 +/-5	3.4	1.9	5.4	3.5
58076-009-ZZ	MZZ-02x02-062/125-30F	850	30 +/-5	2.7	1.3	6.8	4.6
58076-010-ZZ	MZZ-02x02-062/125-20F	850	20 +/-3	1.9	0.9	8.5	6.4
58076-011-ZZ	MZZ-02x02-062/125-10F	850	10 +/-2	1.4	0.4	11.8	9.3
58076-012-ZZ	MZZ-02x02-062/125-05F	850	5 +/-2	1.1	0.2	16.0	11.6
58076-013-ZZ	MZZ-02x02-100/140-50F	850	50 +/-5	4.2	3.0	4.2	3.0
58076-014-ZZ	MZZ-02x02-100/140-40F	850	40 +/-5	3.4	1.9	5.4	3.5
58076-015-ZZ	MZZ-02x02-100/140-30F	850	30 +/-5	2.7	1.3	6.8	4.6
58076-016-ZZ	MZZ-02x02-100/140-20F	850	20 +/-3	1.9	0.9	8.5	6.4
58076-017-ZZ	MZZ-02x02-100/140-10F	850	10 +/-2	1.4	0.4	11.8	9.3
58076-018-ZZ	MZZ-02x02-100/140-05F	850	5 +/-2	1.1	0.2	16.0	11.6
58076-019-MQ	MMQ-02x02-200/240-50F	850	50 +/-5	4.8	3.0	5.1	3.0
58076-020-MQ	MMQ-02x02-200/240-25F	850	25 +/-4	2.8	1.4	8.1	5.7
58076-021-MQ	MMQ-02x02-200/240-06F	850	6 +/-2	1.5	0.2	15.0	11.0
58076-201-ZZ	MZZ-02x02-050/125-50G	1300	50 +/-5	4.2	3.0	4.2	3.0
58076-202-ZZ	MZZ-02x02-050/125-40G	1300	40 +/-5	3.4	1.9	5.4	3.5
58076-203-ZZ	MZZ-02x02-050/125-30G	1300	30 +/-5	2.7	1.3	6.8	4.6
58076-204-ZZ	MZZ-02x02-050/125-20G	1300	20 +/-3	1.9	0.9	8.5	6.4
58076-205-ZZ	MZZ-02x02-050/125-10G	1300	10 +/-2	1.4	0.4	11.8	9.3
58076-206-ZZ	MZZ-02x02-050/125-05G	1300	5 +/-2	1.1	0.2	16.0	11.6
58076-207-ZZ	MZZ-02x02-062/125-50G	1300	50 +/-5	4.2	3.0	4.2	3.0
58076-208-ZZ	MZZ-02x02-062/125-40G	1300	40 +/-5	3.4	1.9	5.4	3.5
58076-209-ZZ	MZZ-02x02-062/125-30G	1300	30 +/-5	2.7	1.3	6.8	4.6
58076-210-ZZ	MZZ-02x02-062/125-20G	1300	20 +/-3	1.9	0.9	8.5	6.4
58076-211-ZZ	MZZ-02x02-062/125-10G	1300	10 +/-2	1.4	0.4	11.8	9.3
58076-212-ZZ	MZZ-02x02-062/125-05G	1300	5 +/-2	1.1	0.2	16.0	11.6
58076-213-ZZ	MZZ-02x02-100/140-50G	1300	50 +/-5	4.2	3.0	4.2	3.0
58076-214-ZZ	MZZ-02x02-100/140-40G	1300	40 +/-5	3.4	1.9	5.4	3.5
58076-215-ZZ	MZZ-02x02-100/140-30G	1300	30 +/-5	2.7	1.3	6.8	4.6
58076-216-ZZ	MZZ-02x02-100/140-20G	1300	20 +/-3	1.9	0.9	8.5	6.4
58076-217-ZZ	MZZ-02x02-100/140-10G	1300	10 +/-2	1.4	0.4	11.8	9.3
58076-218-ZZ	MZZ-02x02-100/140-05G	1300	5 +/-2	1.1	0.2	16.0	11.6

### Notes:

1. The -ZZ at the end of the Part Number specifies the Housing and Leads. Use type "BS", "FL", or "RP" designators. The -MQ specifies the -MQ housing and leads.
2. Specifications are the same for type "BS", "FL", and "RP" housings and leads

### Ordering Information for Nonstandard Multimode 1x2 and 2x2 Couplers

□□□-□□×□□-□□□/□□□-□□-□-□.□/□.□-□□-□□

Multimode Coupler	M
Steel tube / bare fiber leads	BS
Steel tube / large bare fiber leads	MQ
Steel tube / TFE tubed leads	FL
Plastic housing / reinforced jacket leads	RP
1 input	01
2 inputs	02
2 outputs	02
50 µm core fiber	050/125
62.5 µm core fiber	062/125
100 µm core fiber	100/140
200 µm core fiber	200/240
Tap ratio	
1% to 50% expressed as 01 to 50	01
	-
	50
Wavelength Options	
	F - 850
	G - 1300
Input lead length	
0.2 m to maximum lead length	0.2
	-
	1.0
Output lead length	
0.2 m to maximum lead length	0.2
	-
	1.0

See page 29 for ordering information on optional connectors.

## Fiber Optic Multimode Couplers

### MxN Star Couplers

Canstar MxN multimode Star Couplers are designed for use in fiber optic local area networks, industrial control, data acquisition and data distribution systems. Optimum performance and operation under adverse environmental conditions are achieved through licensed use of fused biconical taper coupler patents, with proprietary refinements combined with rigorous quality control.

### Features and Benefits

- Low insertion loss.
- Uniform outputs.
- High directivity.
- Bidirectional.
- Stable over wide temperature range.
- Range of fiber sizes.
- Range of housing options.
- Optional connectorized leads.
- PC board mountable.

Product	Housing Type	Lead Type
HMS	Steel Tube	Acrylate
HML	Steel Tube	TFE
HRS	Compact Plastic Housing	Acrylate
HHS	Large Plastic Housing	Acrylate
HHL	Large Plastic Housing	TFE
HHP	Large Plastic Housing	Reinforced Jacket
TX	EIA 19" Rack	Acrylate

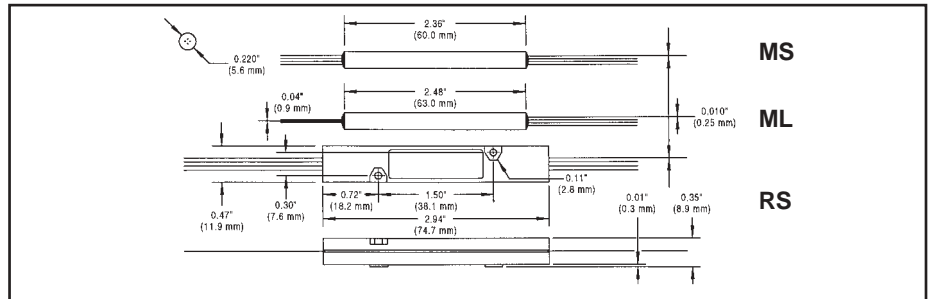

MS & RS - type, 250 μm coated fiber leads with steel tube or plastic housing.

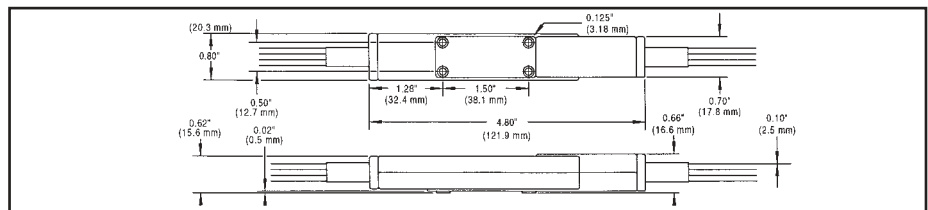

HP, HL & HS - type, plastic housing for reinforced jacketed leads or TFE tubed leads.

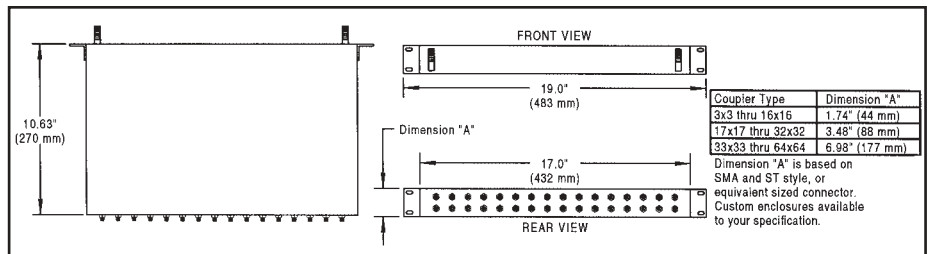

TX - type, Star coupler mounted in EIA 19" rack.

## Specifications for Standard Multimode MxN Star Couplers

Coupling:	Please refer to the following table. Couplers are tested under fully filled launch conditions.
Optical Fiber(s):	Corning™ and Spectran™ acrylate coated, glass clad fibers 50/125/250, 62.5/125/250, and 100/140/250. Contact factory for other fibers, including step index.
Wavelength Range:	Designed for operation over 600 to 1600 nm, guaranteed at 850 nm or 1300 nm as specified.
Directivity:	≥ 40 dB
Temperature Range:	-40 to +85 °C (without connectors)
Dimensions:	Please refer to above drawings.
Lead Lengths:	250 μm coating - Standard = 1 m, Maximum = 10 m (actual lengths may be greater than nominal). 0.9 mm TFE tube - Standard = 55 ± 5 cm, Maximum = 105 ± 5 cm 2.5 mm Reinforced Jacket - Standard = 55 ± 5 cm, Maximum = 105 ± 5 cm

Part Number	Part Descriptor	Wavelength (nm)	Coupling Ratio (%)	Maximum Insertion Loss (db)	Maximum Loss Spread (db)
10003295-A-ZZ-001	HZZ-01X03-AAA/AAA-XXF	850	33.3	5.8	0.8
10003295-A-ZZ-002	HZZ-03X03-AAA/AAA-XXF	850	33.3	5.8	0.8
10003295-A-ZZ-003	HZZ-01X04-AAA/AAA-XXF	850	25.0	7.5	1.0
10003295-A-ZZ-004	HZZ-02X04-AAA/AAA-XXF	850	25.0	7.5	1.0
10003295-A-ZZ-005	HZZ-04X04-AAA/AAA-XXF	850	25.0	7.5	1.0
10003295-A-YY-006	HYY-01X06-AAA/AAA-XXF	850	16.6	9.0	1.0
10003295-A-YY-007	HYY-06X06-AAA/AAA-XXF	850	16.6	9.0	1.0
10003295-A-YY-008	HYY-01X08-AAA/AAA-XXF	850	12.5	11.0	1.5
10003295-A-YY-009	HYY-04X08-AAA/AAA-XXF	850	12.5	11.0	1.5
10003295-A-YY-010	HYY-08X08-AAA/AAA-XXF	850	12.5	11.0	1.5
10003295-A-WW-011	HWW-01X12-AAA/AAA-XXF	850	8.3	12.5	2.0
10003295-A-WW-012	HWW-12X12-AAA/AAA-XXF	850	8.3	12.5	2.0
10003295-A-WW-013	HWW-01X16-AAA/AAA-XXF	850	6.3	14.5	2.0
10003295-A-WW-014	HWW-16X16-AAA/AAA-XXF	850	6.3	14.5	2.0
10003295-A-WW-015	HWW-01X20-AAA/AAA-XXF	850	5.0	15.5	2.0
10003295-A-WW-016	HWW-20X20-AAA/AAA-XXF	850	5.0	15.5	2.0
10003295-A-RR-017	HRR-01X32-AAA/AAA-XXF	850	3.1	17.5	2.0
10003295-A-RR-018	HRR-32X32-AAA/AAA-XXF	850	3.1	17.5	2.0
10003295-A-ZZ-101	HZZ-01X03-AAA/AAA-XXG	1300	33.3	5.8	0.8
10003295-A-ZZ-102	HZZ-03X03-AAA/AAA-XXG	1300	33.3	5.8	0.8
10003295-A-ZZ-103	HZZ-01X04-AAA/AAA-XXG	1300	25.0	7.5	1.0
10003295-A-ZZ-104	HZZ-02X04-AAA/AAA-XXG	1300	25.0	7.5	1.0
10003295-A-ZZ-105	HZZ-04X04-AAA/AAA-XXG	1300	25.0	7.5	1.0
10003295-A-YY-106	HYY-01X06-AAA/AAA-XXG	1300	16.6	9.0	1.0
10003295-A-YY-107	HYY-06X06-AAA/AAA-XXG	1300	16.6	9.0	1.0
10003295-A-YY-108	HYY-01X08-AAA/AAA-XXG	1300	12.5	11.0	1.5
10003295-A-YY-109	HYY-04X08-AAA/AAA-XXG	1300	12.5	11.0	1.5
10003295-A-YY-110	HYY-08X08-AAA/AAA-XXG	1300	12.5	11.0	1.5
10003295-A-WW-111	HWW-01X12-AAA/AAA-XXG	1300	8.3	12.5	2.0
10003295-A-WW-112	HWW-12X12-AAA/AAA-XXG	1300	8.3	12.5	2.0
10003295-A-WW-113	HWW-01X16-AAA/AAA-XXG	1300	6.3	14.5	2.0
10003295-A-WW-114	HWW-16X16-AAA/AAA-XXG	1300	6.3	14.5	2.0
10003295-A-WW-115	HWW-01X20-AAA/AAA-XXG	1300	5.0	15.5	2.0
10003295-A-WW-116	HWW-20X20-AAA/AAA-XXG	1300	5.0	15.5	2.0
10003295-A-RR-117	HRR-01X32-AAA/AAA-XXG	1300	3.1	17.5	2.0
10003295-A-RR-118	HRR-32X32-AAA/AAA-XXG	1300	3.1	17.5	2.0

### Notes:

- The "A" in the Part Number corresponds to the fiber size. Use "1" for 050/125/250, "2" for 62.5/125/250 or "3" for 100/140/250.
- The "ZZ", "YY", "WW", "TT", and "RR" in the Part Number corresponds to the available housing type.  
"ZZ" - ML, MS, RS, HL, HP, HS  
"YY" - MS, RS, HL, HP, HS  
"WW" - HL, HP, HS  
"RR" - HS
- The above table shows a representative subst of the available MxN configurations. generally M can be any integer between 1 and 20 while N can be any integer between M and 20. Please contact the factory for configurations that are not listed above.
- Consult the factory for non standard fibers including step index fibers.



## Ordering Information for Nonstandard Multimode MxN Star Couplers

□□□-□□x□□-□□□/□□□-□□-□-□.□/□.□-□□-□□

Multimode Star Coupler	H
Steel tube / bare fiber leads	MS
Steel tube / TFE tubed leads	ML
Compact plastic housing/ bare fiber leads	RS
Plastic housing / bare fiber leads	HS
Plastic housing / TFE tubed leads	HL
Plastic housing / reinforced jacket leads	HP
Rack mounted assembly	TX
Number of inputs 1 to 32	01 - 32
Number of outputs 3 to 32	03 - 32
50 µm core fiber	050/125
62.5 µm core fiber	062/125
100 µm core fiber	100/140
Nominal even power split	XX
Wavelength Options	F - 850 nm G - 1300 nm
Input lead length 0.2 m to maximum lead length	0.2 - 1.0
Output lead length 0.2 m to maximum lead length	0.2 - 1.0
See page 29 for ordering information on optional connectors.	

## Connectorized Fiber Optic Couplers Singlemode and Multimode

Canstar Fiber Optic Couplers (including taps, splitters, WDM's and attenuators) are available with a wide range of factory installed and tested fiber optic connectors.

### Features and Benefits

- Low additional insertion loss.
- High return loss singlemode with Super, Ultra and Angle PC.
- High return loss multimode with PC technology.
- Hybrid assembly.
- Fast turnaround.



Connectorized coupler.

### Specifications for Connectorized Couplers

Optical Performance:	Please refer to coupler specification for insertion loss values, and add connector insertion loss from table below.
Standard Lead Length:	Please refer to coupler specifications.
Lead Length Tolerance:	+10%/-0% of nominal length.
Temperature Range:	-20 to +70 °C

	<u>Fiber</u>	<u>Connector Options</u>	<u>Polish Options</u>	<u>Insertion Loss/Connector (dB)</u>	<u>Back-reflection (dB)</u>
<b>Singlemode Couplers</b>	SMF-28™	SC, FC, ST, LC	PC	≤ 0.35	> 40
	SMF-28™	SC, FC, ST, LC	SPC	≤ 0.35	> 45
	SMF-28™	SC, FC, ST, LC	UPC	≤ 0.35	> 50
	SMF-28™	SC, FC, ST	APC	≤ 0.5	> 60
<b>Multimode Couplers</b>	50/125	FC, ST	Flat	≤ 0.5	not specified
	50/125	SMA (905 & 906)	Flat	≤ 1.0	not specified
	62.5/125	FC, ST	Flat	≤ 0.5	not specified
	62.5/125	SMA (905 & 906)	Flat	≤ 1.0	not specified
	100/140	FC, ST	Flat	≤ 0.5	not specified
	100/140	SMA (905 & 906)	Flat	≤ 1.0	not specified
	200/240	ST	Flat	≤ 0.5	not specified
	200/240	SMA (905 & 906)	Flat	≤ 1.0	not specified

Please contact factory for low reflection PC polished multimode connectors.

Other connector types available on request.

## Ordering Information for Connectorized Couplers

□□□-□□×□□-□□□/□□□-□□-□-□.□/□.□-□□-□□

Coupler Information (see pages 4 - 27)

### Input connector type

SMA 905	A
SMA 906	B
ST	C
SC	D
FC	E
LC	K
No connector	X
Custom	Z

### Input polish type

Flat	A
PC	B
SPC	C
UPC	D
APC	E
Not specified	X
Custom	Z

### Output connector type

A  
-  
Z

### Output polish type

A  
-  
Z

## Additional FCI Fiber Optics Products

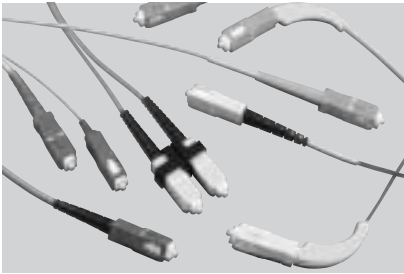

SC Assemblies

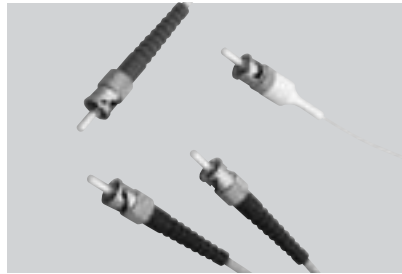

ST® Assemblies

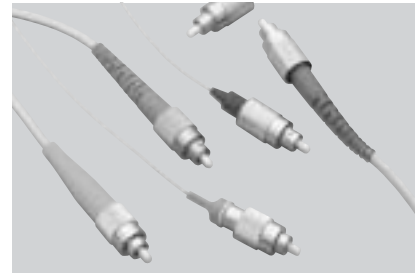

FC Assemblies

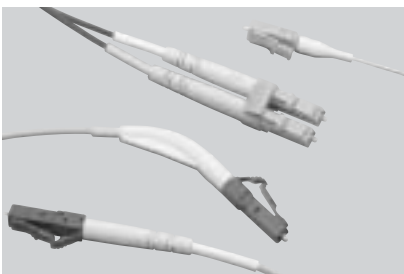

LC Assemblies

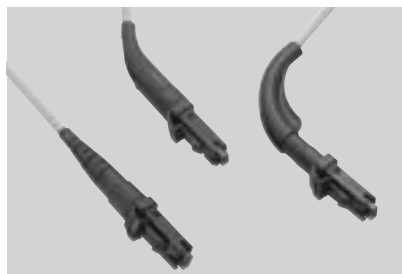

MT-RJ Assemblies

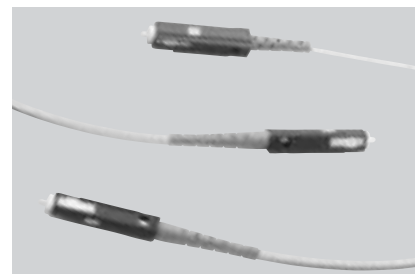

MU Assemblies

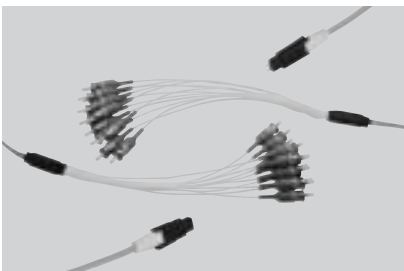

MPO Array Assemblies

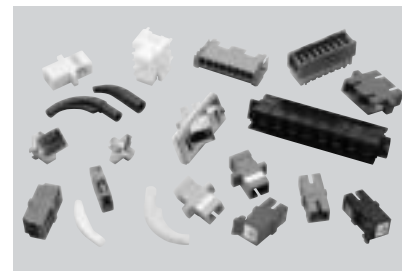

Adapters and Accessories



Box Builds

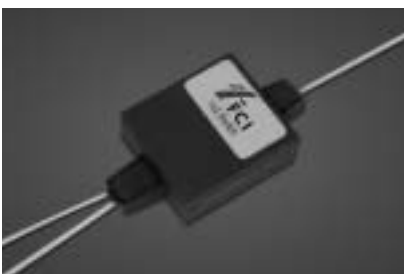

1x2 Single Mode Switch



4- & 8-Channel MUX / DEMUX

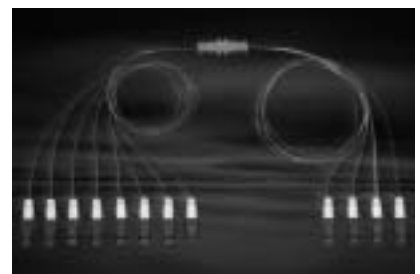

MTMac™ Optical Shuffle

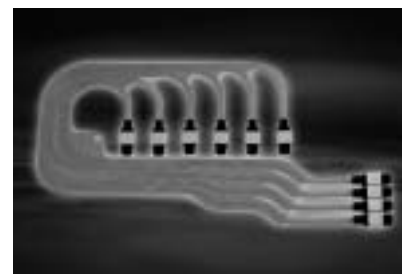

MTMac™ Optical Circuit



## Notes

U.S.A. Tel.: (800) 237-2374; 717-938-7200

Canada Tel.: 905-826-9810

Europe Tel.: 31-73-6206-911

Asia/Pacific Tel.: 65-549-6666

