

---

Datasheet

# BSP-15 Processor Datasheet

**Equator Technologies, Inc.**

Revision H  
September 6, 2002

Document Number: HWR.BSP15.DS.REV.H

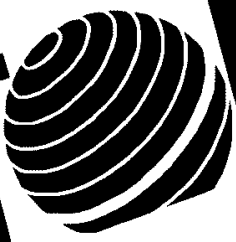
**EQUATOR**  **R**

# Datasheet

## BSP-15 Processor Datasheet

Revision H  
September 6, 2002

Copyright © 2002 Equator Technologies, Inc.  
All rights reserved.

Equator makes no warranty for the use of its products, assumes no responsibility for any errors which may appear in this document, and makes no commitment to update the information contained herein. Equator reserves the right to change or discontinue this product at any time, without notice. There are no express or implied licenses granted hereunder to design or fabricate any integrated circuits based on information in this document.

The following are trademarks of Equator Technologies, Inc., and may be used to identify Equator products only: Equator, the Equator logo, Equator Around, the Equator Around logo, MAP, MAP1000, MAP1000A, MAP-CA, MAP Series, Broadband Signal Processor, BSP, FIRtree, DataStreamer, DS, iMMediaC, iMMediaTools, iMMediaToolsLite, Media Intrinsic, VersaPort, SoftTV, StingRay, Dolphin, Tetra, and Barracuda. Other product and company names contained herein may be trademarks of their respective owners.

The MAP-CA digital signal processor was jointly developed by Equator Technologies, Inc., and Hitachi, Ltd.

Versions of this document released prior to 01-Apr-2002 are:

Copyright © 2000 - 2001 Equator Technologies, Inc., and Hitachi, Ltd.  
All rights reserved.

---

# Table of Contents

---

|  |    |
|--|----|
| Preface .....                              | xi |
| Type style conventions .....               | xi |
| Chapter 1 Introduction .....               | 1  |
| 1.1 Overview .....                         | 1  |
| 1.1.1 Features.....                        | 1  |
| 1.1.2 Related Documents.....               | 3  |
| Chapter 2 Architecture Overview .....      | 5  |
| 2.1 The VLIW Core .....                    | 6  |
| 2.1.1 Execution Units .....                | 6  |
| 2.1.1.1 I-ALU.....                         | 7  |
| 2.1.1.2 IG-ALU.....                        | 7  |
| 2.1.1.3 Simple Interlocks .....            | 7  |
| 2.1.1.4 Extensive Predication.....         | 7  |
| 2.1.2 Register Resources .....             | 7  |
| 2.1.2.1 Global Registers.....              | 8  |
| 2.1.2.2 Breakpoint Registers .....         | 8  |
| 2.1.2.3 General Registers .....            | 8  |
| 2.1.2.4 Predicate Registers.....           | 8  |
| 2.1.2.5 PLC/PLV 128-bit registers.....     | 8  |
| 2.2 Interrupts and Exceptions.....         | 8  |
| 2.2.1 Core Interrupts and Exceptions ..... | 9  |
| 2.2.2 Interrupt Controller.....            | 9  |
| 2.3 Timers.....                            | 10 |
| 2.4 Memory Hierarchy .....                 | 10 |
| 2.4.1 Caches.....                          | 11 |
| 2.4.2 Address Translation.....             | 11 |
| 2.5 Databuses and Controllers.....         | 11 |
| 2.5.1 Memory Interface Controller.....     | 11 |
| 2.5.2 Data Transfer Switch (DTS).....      | 12 |
| 2.5.3 DataStreamer DMA Controller .....    | 12 |
| 2.5.4 PCI Bus.....                         | 12 |
| 2.5.5 I/O Bus.....                         | 13 |
| 2.6 Coprocessors .....                     | 13 |
| 2.6.1 VLx.....                             | 13 |
| 2.6.2 Video Filter.....                    | 13 |
| 2.6.3 DES Module .....                     | 13 |
| 2.7 I/O Interfaces.....                    | 14 |

|  |    |
|--|----|
| 2.7.1 Audio Interfaces .....                   | 14 |
| 2.7.1.1 IEC958 Audio Interface .....           | 14 |
| 2.7.1.2 IIS Interface.....                     | 14 |
| 2.7.2 Video Interfaces.....                    | 14 |
| 2.7.2.1 Transport Channel Interfaces .....     | 14 |
| 2.7.2.2 ITU-656 Input Interface .....          | 15 |
| 2.7.2.3 ITU-656 Output Interface .....         | 15 |
| 2.7.2.4 General Purpose Data Port (GPDP) ..... | 15 |
| 2.7.3 Display Refresh Controller.....          | 15 |
| 2.7.4 Analog RGB .....                         | 15 |
| 2.7.5 Digital RGB.....                         | 16 |
| 2.7.6 IIC Interface Unit .....                 | 16 |
| 2.7.7 ROM Controller.....                      | 16 |
| 2.7.8 Reset Strap.....                         | 17 |
| <br>   |    |
| Chapter 3 BGA Pin-out Assignments .....        | 19 |
| <br>   |    |
| Chapter 4 Signal Descriptions.....             | 25 |
| 4.1 Interface Summary .....                    | 25 |
| 4.2 Legend.....                                | 26 |
| 4.3 Processor Clock.....                       | 26 |
| 4.4 SDRAM.....                                 | 27 |
| 4.5 PCI Bus .....                              | 27 |
| 4.6 IEC958 .....                               | 29 |
| 4.7 IIS .....                                  | 29 |
| 4.8 Multi-Function Signal Pins .....           | 30 |
| 4.8.1 Transport Channel Interfaces (TCI) ..... | 31 |
| 4.8.2 ITU-656 Inputs .....                     | 32 |
| 4.8.3 ITU-656 Output .....                     | 33 |
| 4.8.4 General Purpose Data Port (GPDP) .....   | 33 |
| 4.8.5 Flash ROM .....                          | 34 |
| 4.8.6 Reset Straps .....                       | 34 |
| 4.9 Analog CRT .....                           | 35 |
| 4.10 Digital RGB.....                          | 35 |
| 4.11 IIC.....                                  | 36 |
| 4.12 Boundary Scan (JTAG).....                 | 36 |
| 4.13 Power/Ground Pins .....                   | 37 |
| 4.14 Signal List Summary .....                 | 37 |
| <br>   |    |
| Chapter 5 External Connection Examples .....   | 39 |
| 5.1 SDRAM .....                                | 39 |
| 5.2 IEC958 .....                               | 42 |
| 5.3 IIS .....                                  | 42 |
| 5.4 Transport Channel Interface (TCI).....     | 43 |
| 5.5 NTSC Decoder .....                         | 43 |

|  |    |
|--|----|
| 5.6 NTSC Encoder .....                           | 44 |
| 5.7 CRT .....                                    | 44 |
| 5.8 IIC.....                                     | 45 |
| 5.9 ROM.....                                     | 45 |
| <br>   |    |
| Chapter 6 Electrical Specifications.....         | 47 |
| 6.1 Absolute Maximum Ratings.....                | 47 |
| 6.2 Power Supply Specifications.....             | 48 |
| 6.3 BSP-15 DC Characteristics .....              | 49 |
| 6.4 AC Characteristics.....                      | 50 |
| 6.4.1 PLL reference clock input .....            | 50 |
| 6.4.2 SDRAM interface timing .....               | 50 |
| 6.4.3 PCI bus timing .....                       | 52 |
| 6.4.4 IEC958 interface timing .....              | 54 |
| 6.4.5 IIS interface timing.....                  | 54 |
| 6.4.6 Transport Channel Interface timing.....    | 58 |
| 6.4.7 ITU-R BT.601/656 interface timing.....     | 59 |
| 6.4.8 General Purpose Data Port .....            | 60 |
| 6.4.9 IIC interface timing .....                 | 61 |
| 6.4.10 dRGB timing .....                         | 62 |
| 6.5 Termination Characteristics .....            | 63 |
| 6.5.1 Basic rules .....                          | 63 |
| 6.5.1.1 Weak pull down and pull up defined ..... | 63 |
| 6.5.2 Processor clock.....                       | 64 |
| 6.5.3 ROMCON.....                                | 64 |
| 6.5.4 PCI.....                                   | 65 |
| 6.5.5 ITU-R BT.601/656 out .....                 | 66 |
| 6.5.6 Video input ports .....                    | 66 |
| 6.5.6.1 TCIA .....                               | 66 |
| 6.5.6.2 TCIB.....                                | 67 |
| 6.5.7 ITU-R BT.601/656 IN_A .....                | 67 |
| 6.5.8 ITU-R BT.601/656 IN_B .....                | 67 |
| 6.5.9 IIS .....                                  | 67 |
| 6.5.10 IEC958.....                               | 68 |
| 6.5.11 IIC/DDC .....                             | 68 |
| 6.5.12 JTAG .....                                | 68 |
| 6.5.13 DRC / VideoDAC.....                       | 68 |
| <br>   |    |
| Chapter 7 Thermal Specifications.....            | 71 |
| <br>   |    |
| Chapter 8 Mechanical Specifications.....         | 73 |
| 8.1 EBGA352 Package.....                         | 73 |
| 8.2 Package Materials .....                      | 74 |
| 8.2.1 Materials specification.....               | 74 |
| 8.2.2 Index Location.....                        | 74 |

Appendix A Glossary ..... 75

---

# List of Tables

---

|             |   |    |
|-------------|---|----|
| Table 2-1   | Events That Can Trigger Interrupts .....                | 9  |
| Table 2-2   | Supported Interrupts .....                              | 10 |
| Table 3-1   | Pin Assignments .....                                   | 19 |
| Table 4-1   | Processor clock signal description.....                 | 26 |
| Table 4-2   | Memory interface signals .....                          | 27 |
| Table 4-3   | PCI interface signals.....                              | 27 |
| Table 4-4   | IEC958 interface signals.....                           | 29 |
| Table 4-5   | IIS interface signals .....                             | 29 |
| Table 4-6   | Multiple Signal Pins .....                              | 30 |
| Table 4-7   | Primary TCI Interface Signals.....                      | 31 |
| Table 4-8   | Secondary TCI Interface Signals.....                    | 32 |
| Table 4-9   | Primary ITU-R BT.601/656 Input Interface Signals.....   | 32 |
| Table 4-10  | Secondary ITU-R BT.601/656 Input Interface Signals..... | 33 |
| Table 4-11  | ITU-R BT.601/656 Output Interface Signals .....         | 33 |
| Table 4-12  | GPDP Interface Signals.....                             | 33 |
| Table 4-13  | ROM Interface Signals .....                             | 34 |
| Table 4-14  | Reset Straps .....                                      | 34 |
| Table 4-15  | CRT Interface Signals .....                             | 35 |
| Table 4-16: | Digital RGB interface signals.....                      | 35 |
| Table 4-17  | IIC Interface Signals.....                              | 36 |
| Table 4-18  | JTAG Interface Signals .....                            | 36 |
| Table 4-19  | Power/Ground Pins.....                                  | 37 |
| Table 4-20  | BSP-15 DSP Pin List.....                                | 37 |
| Table 6-1   | Absolute Maximum Ratings.....                           | 47 |
| Table 6-2   | Voltage Variation .....                                 | 48 |
| Table 6-3   | Steady State Current .....                              | 48 |
| Table 6-4   | Input/Output Signals.....                               | 49 |
| Table 6-5   | Video DAC outputs - aRGB mode .....                     | 49 |
| Table 6-6   | PLL Reference Clock Input Conditions .....              | 50 |
| Table 6-7   | SDRAM interface timing parameters .....                 | 51 |
| Table 6-8   | PCI interface timing parameters .....                   | 53 |
| Table 6-9   | PCI measurement conditions .....                        | 53 |
| Table 6-10  | IEC958 interface timing parameters.....                 | 54 |
| Table 6-12  | IIS output timing parameters .....                      | 55 |
| Table 6-11  | IIS clock ratios.....                                   | 55 |

|            |   |    |
|------------|---|----|
| Table 6-13 | IIS input timing parameters - slave mode.....             | 56 |
| Table 6-14 | IIS input timing parameters - master mode .....           | 57 |
| Table 6-15 | TCI timing parameters.....                                | 58 |
| Table 6-16 | ITU-R BT.601/656 input interface timing parameters .....  | 59 |
| Table 6-17 | ITU-R BT.601/656 output interface timing parameters ..... | 60 |
| Table 6-18 | GPDP input timing parameters.....                         | 60 |
| Table 6-19 | GPDP output timing parameters.....                        | 61 |
| Table 6-20 | IIC interface timing parameters.....                      | 62 |
| Table 6-21 | Processor Clock Terminations.....                         | 64 |
| Table 6-22 | ROMCOM Terminations.....                                  | 64 |
| Table 6-23 | PCI Termination .....                                     | 65 |
| Table 6-24 | ITU-R BT.601/656 Out Termination.....                     | 66 |
| Table 6-25 | TCIA Terminations.....                                    | 66 |
| Table 6-26 | TCIA Terminations.....                                    | 67 |
| Table 6-27 | ITU-R BT.601/656 IN_A Terminations .....                  | 67 |
| Table 6-28 | ITU-R BT.601/656 IN_B Terminations .....                  | 67 |
| Table 6-29 | IIS Terminations .....                                    | 67 |
| Table 6-30 | IEC 958 Terminations .....                                | 68 |
| Table 6-31 | IIC/DDC Terminations .....                                | 68 |
| Table 6-32 | JTAG Terminations .....                                   | 68 |
| Table 6-33 | DRC / VideoDAC.....                                       | 68 |
| Table 7-1  | Thermal Parameters.....                                   | 71 |
| Table 8-1  | Materials specification.....                              | 74 |



---

# List of Figures

---

|             |  |    |
|-------------|--|----|
| Figure 1.1  | Equator BSP-15 Processor System Diagram.....                       | 2  |
| Figure 2.1  | BSP-15 DSP/CPU block diagram.....                                  | 5  |
| Figure 3.1  | BSP-15 DSP pins viewed from bottom .....                           | 22 |
| Figure 3.2  | BSP-15 DSP pins viewed from top .....                              | 23 |
| Figure 4.1  | BSP-15 Interface.....  | 25 |
| Figure 5.1  | 64-bit, 4 MB configuration using $\times 32$ , 8 Mb parts.....     | 39 |
| Figure 5.2  | 64-bit, 16 MB configuration using $\times 8$ , 16 Mb parts.....    | 39 |
| Figure 5.3  | 64-bit, 16 MB configuration using $\times 16$ 16 Mb parts.....     | 40 |
| Figure 5.4  | 64-bit, 64 MB configuration using $\times 16$ , 64 Mb parts.....   | 40 |
| Figure 5.5  | 64-bit, 64 MB configuration using $\times 16$ , 128 Mb parts.....  | 41 |
| Figure 5.6  | 64-bit, 128 MB configuration using $\times 16$ , 128 Mb parts..... | 41 |
| Figure 5.7  | IEC958 interface.....  | 42 |
| Figure 5.8  | IIS interface .....  | 42 |
| Figure 5.9  | Transport Channel Interface .....                                  | 43 |
| Figure 5.10 | ITU-R BT.656 NTSC/PAL decoder interface.....                       | 43 |
| Figure 5.11 | NTSC/PAL encoder interface.....                                    | 44 |
| Figure 5.12 | CRT .....  | 44 |
| Figure 5.13 | IIC interface.....   | 45 |
| Figure 5.14 | ROM connections .....  | 45 |
| Figure 6.1  | SDRAM timing measurement conditions.....                           | 50 |
| Figure 6.2  | PCI output timing measurement conditions .....                     | 52 |
| Figure 6.3  | PCI input timing measurement conditions .....                      | 52 |
| Figure 6.4  | IIS data format.....   | 54 |
| Figure 6.5  | IIS output timing measurement conditions.....                      | 55 |
| Figure 6.6  | IIS input timing measurement - slave mode.....                     | 56 |
| Figure 6.7  | IIS input timing measurement - master mode .....                   | 56 |
| Figure 6.8  | Internal serial clock generation for IIS master mode .....         | 57 |
| Figure 6.9  | TCI timing measurement conditions .....                            | 58 |
| Figure 6.10 | ITU-R BT.601/656 input timing measurement conditions.....          | 59 |
| Figure 6.11 | ITU-R BT.601/656 output timing measurement conditions.....         | 59 |
| Figure 6.12 | GPDP input timing measurement conditions .....                     | 60 |
| Figure 6.13 | GPDP output timing measurement conditions .....                    | 60 |
| Figure 6.14 | IIC timing measurement conditions .....                            | 61 |

Figure 6.15 dRGB timing diagram ..... 62  
Figure 8.1 EBGA352 Package ..... 73  
Figure 8.2 Index location ..... 74

---

# Preface

---

## Type style conventions

With the exception of section and subsection headings, the formatting of text in the following document adheres to the following conventions:

- Normal descriptive text is presented in Times New Roman font.
- *Italicized Times New Roman* text is used for document titles.
- **Times New Roman** text is used for emphasis in normal descriptive text.

Any input or output text for any computer program is presented in `Courier New` font. This includes source code, command-line text, and program output.

*Courier New* text is used for any portion of a path name, including individual file names.

**Courier New** text is used for any placeholder for a set of text input or output items for a program.



---

# Chapter 1 Introduction

---

## 1.1 Overview

The Equator BSP™-15 processor is the latest member of the Equator Broadband Signal Processor family offering highly integrated single chip solutions for broadband products such as set-top boxes, digital televisions, video conferencing systems, medical imaging products, digital video editing equipment, and office automation products.

The processing power of the BSP-15 processor combined with iMMediaTools™ code generation environment and library of audio and video codecs provide a proven and effective solution for building rapidly evolving broadband solutions.

### 1.1.1 Features

The Equator BSP-15 processor provides the following features:

- **Advanced four-issue, super pipelined Very Long Instruction Word Processor**

The VLIW processor provides four integer ALUs, two 64-bit SIMD ALUs, and two 128-bit SIMD ALUs. The processor has 32 1-bit predicate registers, eight 128-bit registers, and 128 32-bit registers, which can be paired into 64-bit registers.

- **Advanced high throughput memory hierarchy**

Instructions are provided to the VLIW processor by a 32 KB two-way set-associative instruction cache with an LRU replacement policy. Instructions are stored in compressed format. Data is provided to the processor by a 32 KB four-way set associative, four-bank interleaved data cache with an LRU replacement policy. Memory protection is provided by separate instruction, data and DMA MMUs, each with a fully set-associative 16 entry TLB. Off chip memory is connected via a glueless high speed 64-bit SDRAM/SGRAM interface supporting up to 128 MB of external memory.

- **Specialized coprocessors**

Variable length encoding and decoding is handled by the VLx coprocessor with 4 KB instruction and 4 KB data memory. The Video Filter coprocessor provides up to 4 vertical tap and 5 horizontal tap filtering, aided by a 6 KB line buffer. High data throughput is provided by the DataStreamer™, a programmable 64 channel DMA controller with 8 KB of buffering. The Display Refresh Controller provides color space conversion, palette table lookup and hardware cursor functionality. A DES coprocessor accelerates DES encryption and decryption.

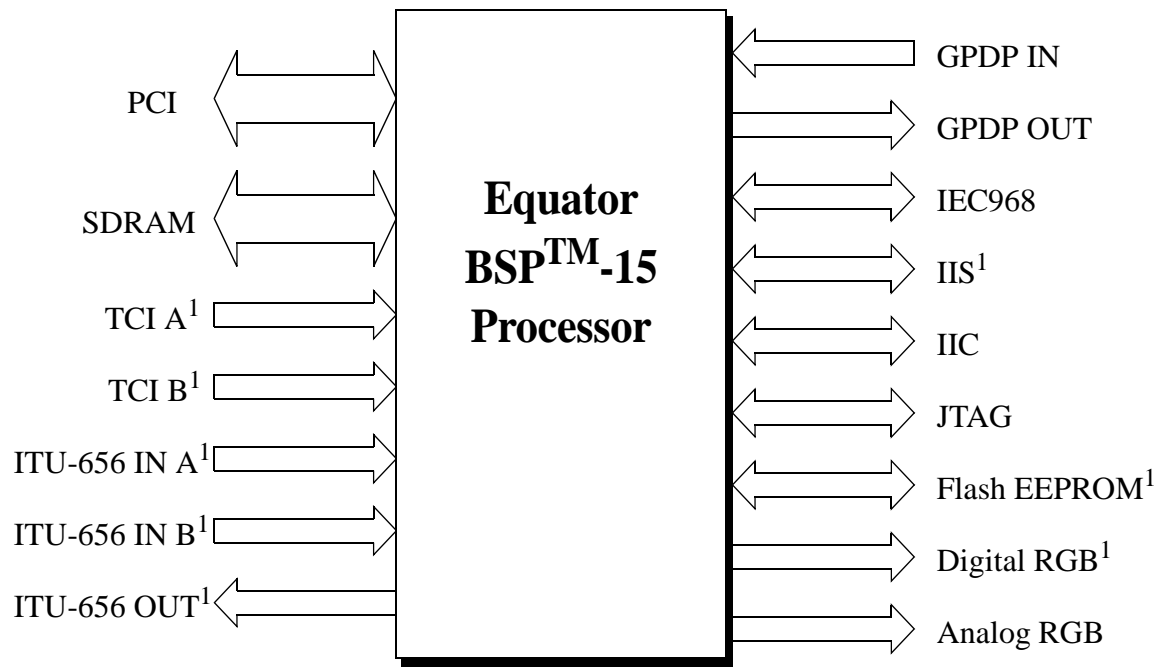

**Figure 1.1 Equator BSP-15 Processor System Diagram**

- **I/O interfaces**

A large number of interfaces is available, as shown in Figure 1.1.

- 33/66 MHz 32-bit PCI interface
- 64-bit SDRAM/SGRAM interface
- 2 DVB compliant transport channel interfaces<sup>1</sup>
- 2 ITU 656 inputs<sup>1</sup>
- 1 ITU 656 output<sup>1</sup>
- 8-bit general purpose data input port (GPDP)<sup>1</sup>
- 8-bit general purpose data output port (GPDP)<sup>1</sup>
- Analog RGB interface
- Digital RGB flat panel interface<sup>1</sup>
- Flash EEPROM interface<sup>1</sup>
- IIC master/slave interface
- IIS interface<sup>1</sup>

---

1. Interface shares pins with other interface(s)

- IEC958 interface<sup>1</sup>
- JTAG interface

Not all interfaces can be active at the same time because of pin multiplexing:

- TCI A, ITU-656 IN A, GPDP IN, and digital RGB 12/18/24 bit modes share pins and cannot be used at the same time
- TCI B, ITU-656 IN B (601 mode) and digital RGB 18/24 bit mode share pins and cannot be used at the same time
- IIS and Flash EEPROM interface share pins and cannot be used at the same time<sup>2</sup>
- GPDP OUT, Flash EEPROM and digital RGB 12/18/24 bit modes share pins and cannot be used at the same time
- TCI A and B share pins with digital RGB 12/18/24 bit modes share pins and neither one can be used together with digital RGB.

### 1.1.2 Related Documents

Equator Hardware Reference, Volume 1: *BSP-15 Instruction set*, HWR.BSP15.V1

Equator Hardware Reference, Volume 2: *BSP-15 VLx and Video Filter*, HWR.BSP15.V2

Equator Hardware Reference, Volume 3: *BSP-15 Data Controllers*, HWR.BSP15.V3

Equator Hardware Reference, Volume 4: *BSP-15 I/O Interfaces*, HWR.BSP15.V4

Equator Hardware Reference, Volume 5: *BSP-15 PIO & Register Maps*, HWR.BSP15.V5

---

1. Interface shares pins with other interface(s)

2. A special IIS bypass mode provides single channel IIS via a TCI IN A pin





## Chapter 2 Architecture Overview

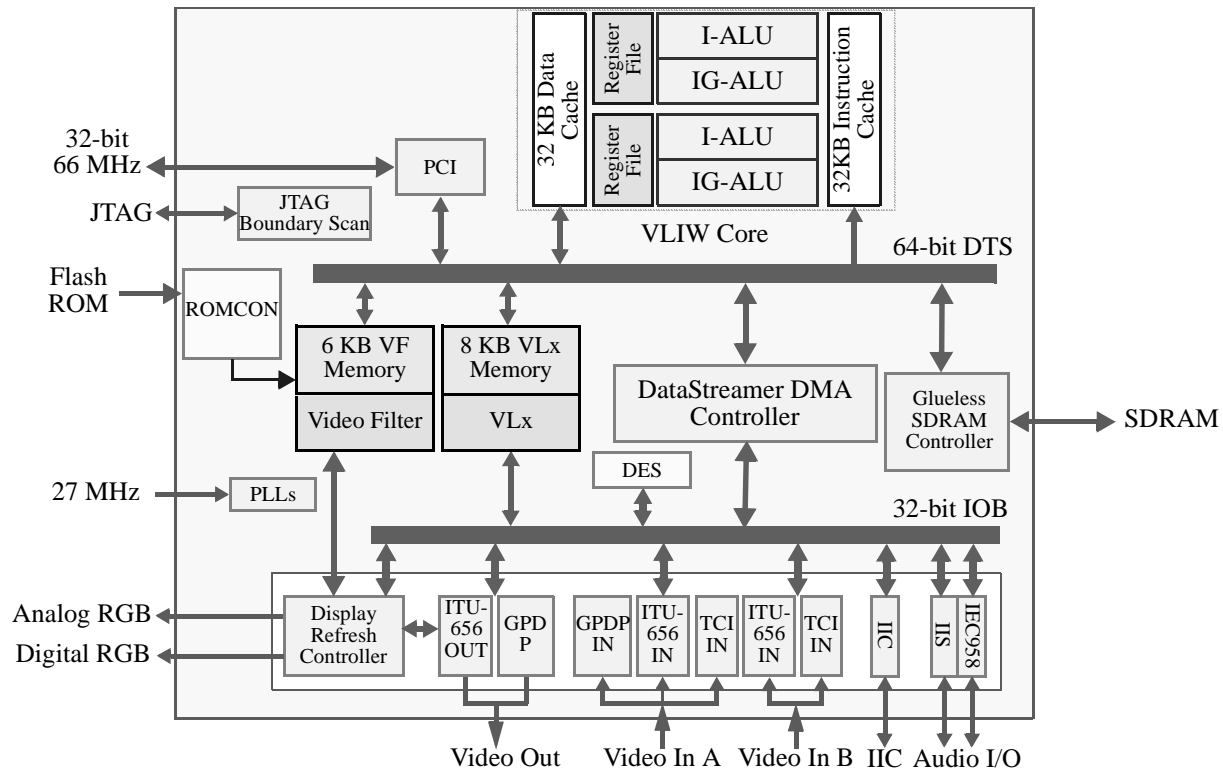

**Figure 2.1 BSP-15 DSP/CPU block diagram**

The BSP-15 family of digital signal processors are high-performance processors providing broadband applications with solutions addressing the convergence of communications, consumer appliances and general purpose computing. The BSP-15 DSP family of chips combines general-purpose RISC-like data processing with high-performance signal and image processing. The BSP-15 DSP family supports C-like programmable video, image, and signal processing software implementations of compression and decompression algorithms. The BSP-15 DSP family matches the cost and performance features of dedicated fixed-function chips, with the added flexibility to rapidly respond to evolving standards. Figure 2.1 shows a block diagram of the typical BSP-15 DSP. The BSP-15 DSP consists of a VLIW core, programmable coprocessors, on-chip memories and I/O interfaces.

The main VLIW core executes four operations in parallel and supports partitioned SIMD operations for 8-, 16-, 32-, and 64-bit data types. Coprocessors on the BSP-15 DSP help accelerate serial operations like variable length encoding/decoding and video filtering.

Several audio/video I/O interfaces are supported, including ITU-R BT.601/656 input and output; dual MPEG-2 transport channel interface (TCI); IEC958 and IIS digital audio interfaces. Two video 656 inputs can be used at the same time. The Display Refresh Controller (DRC) supports both analog and digital RGB outputs. In addition it provides hardware support for graphics/video overlay, hardware cursor, and color space conversion. An IIC control bus interface is also provided.

These I/O functions execute in parallel with the CPU and eliminate the need for several external ASICs with their associated cost and bandwidth issues.

A glueless 64-bit wide SDRAM interface connects the BSP-15 processor to external memory with a maximum size of 128 MB. The BSP-15 DSP supports a 128 MB maximum memory size. A 32-bit 33/66 MHz PCI bus interface is also supported. The BSP-15 DSP boots from either the PCI bus or the Flash ROM interface.

There are three on-chip PLLs (core/SDRAM, pixel, audio) that generate all the internal clocks from a single 27 MHz external clock input (`pclk`). The `tci_vdac` pin can be used to output a controlling signal that can be used to drive a one bit sigma-delta modulator for an external VCXO which in turns modulates the frequency on `pclk`.

## 2.1 The VLIW Core

Real-time processing of multimedia data stresses processor performance, I/O performance and memory performance. There are three basic ways to increase a processor's performance: decrease the cycle time, decrease the number of cycles required to execute an instruction, and execute more instructions per cycle. The first two are becoming increasingly difficult to improve beyond process scheduling, while the last (executing more instructions per cycle) is now receiving more attention. Executing more instructions per cycle exploits the natural parallelism available in most software routines. Very Long Instruction Word (VLIW) processors use this parallelism by packing multiple operations into a single instruction word, which is then executed as a unit.

VLIW architectures differ from superscalar architectures in that the grouping and scheduling of instructions for execution is done at compile time, rather than execution time. The compiler searches for eligible operations, checks for dependencies and resource conflicts, and packages these eligible operations into VLIW instructions. The VLIW compiler can explore beyond the limited search window seen in superscalar architectures and cross natural boundaries, such as branches, to search for opportunities for enhanced parallelism. The Equator compiler uses a technique known as "trace scheduling" to search a whole routine for eligible operations.

By moving the difficult task of finding parallelism into software, VLIW compiler techniques dramatically simplify the CPU design by reducing gate count and freeing valuable die area for other performance enhancements or lower chip costs. While VLIW is primarily designed to exploit parallelism, its simplification of the processor architecture allows for reduced cycle times as well.

### 2.1.1 Execution Units

The BSP-15 DSP operations are primarily three-operand RISC operations. As in any typical RISC architecture, load and store operations are the only means of referencing memory. The BSP-15 DSP has four functional units: two I-ALUs and two IG-ALUs. Each I-ALU contains a load-store unit, an integer ALU, and a branch unit. Each IG-ALU contains an integer/graphics unit and a multimedia operation unit. The I-ALU and IG-ALU support different operations, but many integer and logical operations are implemented in both units. This overlap allows the compiler to schedule more operations in parallel and make more efficient use of all the functional units.

There are 128 32-bit registers usable separately or in pairs as 64-bit registers, 32 1-bit predicate registers, and eight special 128-bit registers for the VLIW core CPU. These 128-bit (PLC/PLV) registers are used for FIR filter, SAD, FFT, ADD, DCT, and other specialized partitioned integer operations. The large register files help minimize unnecessary instruction dependencies caused by logically distinct register reuses.

Each BSP-15 DSP instruction contains four operations per cycle. The Media Intrinsic instructions include partitioned operations over these media data types. Load and store operations can perform one, two, four, and eight byte accesses, with support for both little-endian and big-endian byte orderings.

Dynamic address translation and virtual memory protection are fully supported. The 1-bit logical values are also used to support predicated execution, which substantially enhances available parallelism by allowing partial speculation and eliminating branching.

### 2.1.1.1 I-ALU

The I-ALU performs the following operations:

- 32-bit integer arithmetic operations including compare
- Logical and bitwise logical operations whose results can be sent to general or predicate registers
- Address calculations for indexed addressing
- Memory reference
- Branching
- System control operations

### 2.1.1.2 IG-ALU

The IG-ALU performs the following operations:

- 32-bit integer arithmetic operations (same as the I-ALU)
- Logical and bitwise logical operations (same as the I-ALU)
- 64-bit integer arithmetic operations
- Shift/extract/merge operations
- 64-bit SIMD operations (with 8-bit, 16-bit, and 32-bit partitions) including selection, comparison, selection of maximums and minimums, addition, multiply-add, complex multiplication, inner product, and sum of absolute differences
- 128-bit partitioned (with 8-bit, 16-bit, and 32-bit partitions) SIMD operations including inner-product with new partition shift-in for efficient FIR operation and sum of absolute differences with new partition shift-in for efficient block matching operation

### 2.1.1.3 Simple Interlocks

Certain operations require more than one cycle to complete. No hardware interlocks are needed to prevent issue of an operation that attempts to read a result not yet completed. The VLIW compiler is responsible for correct scheduling, not hardware. Register scoreboarding is supported for outstanding loads.

### 2.1.1.4 Extensive Predication

Nearly all operations can have their effect controlled by the value of a selected (1-bit) predicate register. A predicate register is tested to determine whether or not the operation should be performed. This allows the compiler to aggressively convert control flow into data flow, enabling a substantially higher degree of instruction-level parallelism. This also greatly helps to reduce any penalties for branching, without the cost and complexity of hardware branch prediction typical in other General Purpose processors.

## 2.1.2 Register Resources

There are several types of registers on the BSP-15 DSP. These include system registers, breakpoint registers, general purpose registers, predicate registers, and special purpose 128-bit registers.

### 2.1.2.1 Global Registers

Global registers on the BSP-15 DSP consist of system registers and implementation-dependent I/O registers (PIO registers). Dedicated operations manipulate the system registers; conventional load and store operations manipulate the I/O registers.

### 2.1.2.2 Breakpoint Registers

BSP-15 DSP has two sets of breakpoint registers: instruction-breakpoint and data-breakpoint registers. These registers provide hardware breakpoint capability for various debugging tools. Instruction-breakpoint registers cause an exception when an operation in the specified address is about to be executed. Similarly, the data-breakpoint registers cause an exception when the data at the specified address is about to be accessed. In both cases, a mask can be used to specify a range of addresses.

By registering an exception handling routine associated with either of these exceptions, a software developer can control what happens when a hardware breakpoint occurs. For example, the exception handling routine may be used to signal an external application such as a source-level debugger that a breakpoint has occurred.

### 2.1.2.3 General Registers

There are 128 32-bit registers that can be treated as 64-bit general registers using even-odd pairs of the 32-bit registers.

### 2.1.2.4 Predicate Registers

There are 32 1-bit predicate registers. Predicate registers are used in predicated operations, logical operations, and branches. They provide a destination for operations with a judged condition.

### 2.1.2.5 PLC/PLV 128-bit registers

The IG-ALU has eight special 128-bit registers – two pairs of Partitioned Local Constant (PLC) registers and two pairs of Partitioned Local Variable (PLV) registers. These registers are used for powerful SIMD DSP partitioned operations. The registers can be configured as sixteen 8-bit operation partitions, eight 16-bit operation partitions, or four 32-bit operation partitions. For numerous digital signal processing and compression algorithms, the SIMD operations allows the BSP-15 DSP to match the cost/performance of fixed-function chips without the loss of re-programmability.

## 2.2 Interrupts and Exceptions

The BSP-15 DSP has a flexible interrupt structure. Interrupts and exceptions internal to the core are reflected directly in system registers. All other interrupts from on-chip devices and PCI interrupts from external devices are gathered by an on-chip interrupt controller. The interrupt controller also provides a number of software interrupts.

Routing, masking, and prioritization of interrupts is completely software programmable. Each of the interrupts handled by the interrupt controller can be individually masked, or routed to one of four core interrupts or to one of two PCI interrupt signals.

## 2.2.1 Core Interrupts and Exceptions

Table 2-1 lists the events that can trigger interrupts or exceptions within the core. When an event occurs, a bit is set in an “Event Seen” system register. If the event is not masked (or not maskable), the address for a handler will be fetched from one of nine Event Vector system registers, depending on the event.

**Table 2-1 Events That Can Trigger Interrupts**

| Name        | Event                                      | Maskable? |
|-------------|--|-----------|
| IO0.IO3     | I/O interrupts (from interrupt controller) | Yes       |
| SINT0.SINT1 | Software interrupts                        | Yes       |
| FCNT        | Free running counter overflow              | Yes       |
| INTV0.INTV1 | Interval timers                            | Yes       |
| ILPC        | Illegal program counter                    | No        |
| IBPT        | Instruction address break                  | Yes       |
| BPOP        | Breakpoint operation                       | No        |
| SYS         | System call (trap instruction)             | No        |
| ITLBAA      | ITLB application access                    | No        |
| ITLBR       | ITLB reference                             | No        |
| ITLBM       | ITLB miss                                  | No        |
| ILLO        | Illegal operation                          | No        |
| PLV         | Privilege violation                        | No        |
| DBPT        | Data address break                         | Yes       |
| DALN        | Data alignment error                       | No        |
| DTLBKW      | DTLB kernel write                          | No        |
| DTLBAW      | DTLB application write                     | No        |
| DTLBAA      | DTLB application access                    | No        |
| DTLBR       | DTLB reference                             | No        |
| DTLBM       | DTLB miss                                  | No        |

## 2.2.2 Interrupt Controller

The BSP-15 DSP’s interrupt controller supports multiple maskable interrupts from outside of the core. Non-core interrupt sources include on-chip devices such as TCI, the DRC, the DataStreamer DMA controller, and PCI interrupts from external devices or hosts. Software-generated shoulder-tap interrupts are provided for multiprocessing or inter-process communication support.

The BSP-15 DSP interrupts can be examined and controlled via PIO registers in the ROMCON control block. Routing and masking of interrupts is programmable. Each interrupt can be individually masked or routed to one of four core interrupts or to one of two PCI interrupt signals. Software interrupts can be similarly masked and routed. They may be asserted or de-asserted under software control.

Table 2-2 shows the supported interrupts.

**Table 2-2 Supported Interrupts**

| Name            | Interrupt                            |
|-----------------|--------------------------------------|
| IrqAlwaysOne    | debug interrupt, always asserted     |
| IrqIIC          | IIC                                  |
| IrqTCI0         | primary TCI                          |
| IrqDRC          | display refresh controller           |
| IrqNTSCIn0      | primary ITU-R BT.601/656 in          |
| IrqNTSCIn1      | secondary ITU-R BT.601/656 in        |
| IrqTCI1         | secondary TCI                        |
| IrqPCIAA        | PCI interrupt pin A                  |
| IrqPCIAB        | PCI interrupt pin B                  |
| IrqNTSCOut      | ITU-R BT.601/656 output              |
| IrqIEC958       | IEC958 audio                         |
| IrqIIS          | IIS audio                            |
| IrqPCIAPME      | PCIA power management event          |
| IrqDS0          | DS DMA controller interrupt 0        |
| IrqDS1          | DS DMA controller interrupt 1        |
| IrqDSTLB        | DS DMA controller TLB miss           |
| IrqDSBufOvrFlow | DS DMA controller I/O input overflow |
| IrqSoftWare     | Software-controlled interrupts       |

## 2.3 Timers

The BSP-15 DSP has two independent programmable interval timers plus a free-running counter. Each interval timer has a 32-bit counter register and period register. The counter is incremented once per cycle. When the counter reaches the period value, the counter is reloaded, a bit is set in the system Event Seen Register (ESR), and a maskable interrupt is asserted. The free-running counter counts up once per cycle as well. When it overflows to zero, a bit is set in ESR and a maskable interrupt is asserted.

The transport channel interface also has a programmable timer that counts at a rate of 27 MHz and can be used to generate an interrupt upon rollover.

## 2.4 Memory Hierarchy

The BSP-15 DSP supports several on-chip memories and access to external SDRAM and other memories via the PCI bus. The VLIW core is equipped with a 32 KB instruction cache and 32 KB data cache used for caching instructions and data from SDRAM. In addition to supporting I-ALU ports, the data cache supports a port to the DTS (Data Transfer Switch), which makes data in the data cache available to the DataStreamer DMA controller.

A 4KB instruction memory and a 4 KB data memory are used by the VLx coprocessor. The Video Filter uses a 6 KB line buffer memory. These memories, totaling 14 KB, are also accessible from the VLIW core through un-cached load/store operations. In addition, these memories are also available to the

DataStreamer DMA controller and for external use via PCI. The line buffer memory is used to store the content of Flash ROM at system boot up.

## 2.4.1 Caches

The BSP-15 DSP has a 32 KB instruction cache and a separate, multi-bank 32 KB data cache. Both caches are physically addressed, so that problems of aliasing and context switching do not arise. For fast address translation, the cache index is virtual but the tags are physical.

The instruction cache holds instructions in a compressed form. It is organized as a two-way set associative cache with a LRU replacement algorithm.

The data cache is a 32 KB, four-way set-associative (with true LRU replacement), write-back cache. The data cache supports four simultaneous 64-bit data accesses per cycle. The cache is non-blocking; up to eight outstanding misses to different cache lines and up to 48 outstanding misses overall are allowed.

## 2.4.2 Address Translation

The BSP-15 DSP provides memory management support in the form of separate TLBs for the instruction stream, each I-ALU data access, and the DataStreamer DMA controller. The four TLBs (ITLB, two DTLBs, and DSTLB) can be programmed independently.

The DTS-ID is part of the virtual address and can be used to direct accesses when the TLBs are disabled.

Each TLB has sixteen fully-associative entries. Each entry contains a Virtual Page Number (VPN), an 8-bit Address Space Identifier (ASID), access protection bits, and page size information. Each entry can map a page of any valid size, where the valid sizes are 16KB, 64KB, 256KB, 1MB, 4MB, 16MB, 64MB, 256MB, and 1GB.

When a TLB miss occurs, an exception is generated. The exception handler can modify a TLB entry and retry the failed operation. Separate exception handlers can be installed for data, instruction, and DataStreamer DMA controller TLB misses.

## 2.5 Databuses and Controllers

The various buses and controllers on the BSP-15 DSP are described in the following sections.

### 2.5.1 Memory Interface Controller

The Memory Controller Unit allows customers to easily build high-performance, external memory up to 128MB using SDRAM/SGRAM without any external glue logic. Local memory supports externally initiated PCI accesses through the Address Translation Unit within the PCI module.

The Memory Controller Unit also includes hardware that queues, prioritizes, and transfers data from memory to memory or from memory to cache asynchronously to the initiating software.

The on-chip core PLL generates the clock for the memory controller and provides clock synchronization between the BSP-15 DSP and external SDRAM. This provides support for various combinations of CPU core and memory speeds.

## 2.5.2 Data Transfer Switch (DTS)

The DTS is a split-transaction bus. The DTS contains the data and address buses, a high speed bridging system, and a bus arbiter. The bridge, arbiter, and bus arrangement is a very high-speed communication solution that allows multiple media applications to be executed concurrently.

The arbiter can handle multiple requestors using priority based scheduling.

## 2.5.3 DataStreamer DMA Controller

The DataStreamer DMA controller is a high performance, programmable DMA engine that performs buffered data transfer between different BSP-15 DSP memory subsystems or between memories and I/O devices. The DataStreamer DMA controller is programmed and controlled by software. The DataStreamer DMA controller then performs the requested transfer without further intervention from the core.

The DataStreamer DMA controller can perform the following classes of transfers:

- memory-to-memory: perform block transfers, preload data into the cache, fill a memory region with 0 or 1 bits
- memory-to-I/O and I/O-to-memory: perform I/O transfers

The DataStreamer DMA controller features include:

- an 8KB internal memory that can be partitioned into as many as 64 variable-sized buffers. Each buffer is simultaneously the sink for an input I/O or memory channel and the source for an output I/O or memory channel.
- sixty-four independent programmable channels for transfers between various memories and the DataStreamer DMA controller's internal buffer,
- Channel programs, called Descriptor Lists, allow transfers of arbitrary or infinite length to be specified. Regular and irregular patterns of contiguous or non-contiguous transfers are easy to specify.
- Memories that can be read or written include SDRAM, on-chip memories, and PCI bus accessible memories. Cache preloading can also be performed.
- Interrupts can be triggered by descriptors, allowing end-of-transfer or mid-stream interrupts to be generated.

## 2.5.4 PCI Bus

The PCI unit implements a 32-bit PCI 2.1 interface with speed up to 66 MHz. The PCI interface is a single function device with two BARs. Certain fields in the configuration registers may be initialized on power-up through ROM control. As a PCI target, the PCI interface allows access to the BSP-15 DSP's SDRAM (coherently or non-coherently with respect to the Data Cache). The PCI interface also allows access to several programmer-visible control registers, PIO space and SDRAM. As a PCI master, the PCI interface allows the VLIW core, the DataStreamer DMA controller, and coprocessors to initiate PCI bus requests. The PCI unit can initiate memory, I/O and configuration commands on the PCI bus.

The BSP-15 DSP can act as a host on the PCI bus. There are three pairs of request/grant lines for other devices on a PCI bus. This enables a multi-processor configuration to connect up to four BSP-15 DSPs together on a PCI bus without a bridge. This is very useful for multi-MAP board products.

The PCI interface implements two separate interrupt lines. If the BSP-15 DSP is not the host, any internal interrupt can be routed to any of these PC interrupts. If the BSP-15 DSP is the host, the PCI interrupts are sampled by the BSP-15 DSP and can be routed to the BSP-15 DSP's VLIW core.



The BSP-15 processor support both 3.3V and 5V PCI.

## 2.5.5 I/O Bus

All on-chip peripheral devices are connected via the internal I/O Bus (IOB). This is a 32-bit internal bus running at one half of the VLIW core frequency. The IOB connects to the DTS through the DataStreamer DMA controller. The IOB can handle real-time requests.

## 2.6 Coprocessors

Coprocessors on the BSP-15 DSP help off-load “serial” processing tasks from the VLIW core or accelerate special purpose processing for video operations. The coprocessors operate in parallel with the VLIW core resulting in significantly improved video processing.

### 2.6.1 VLx

The Variable Length Encoder/Decoder or VLx is a 16-bit RISC coprocessor with thirty-two 16-bit registers. The VLx off-loads the bit sequential tasks of variable length encoding and variable length decoding (VLE/VLD) from the VLIW core and accelerates applications such as JPEG, H.263, MPEG2 & 4, H.263, JBIG, and DV. The VLx includes special purpose hardware for bitstream processing, hardware-accelerated MPEG-2 table lookup, and general purpose variable length decoding.

### 2.6.2 Video Filter

A polyphase (8 phase) 2D Video Filter takes 4:2:0 or 4:2:2 YUV stream as input and scales either up or down as required. 4 (vertical)  $\times$  5 (horizontal) filters support up to 768 horizontal pixels, 3  $\times$  5 up to 1024 horizontal pixels, and 2  $\times$  5 up to 1536 horizontal pixels. The Video Filter pumps out scaled 4:4:4 YUV data to the DRC through the video bus. The Video Filter can also pump out 4:4:4 YUV data to the SDRAM for debug purposes. Its features are described below.

- Supports 8-bit coefficients.
- Supports both interspersed and co-sited pixel positioning.
- Supports vertical 4-tap polyphase (8-phase) filters for luminance and chrominance.
- Supports horizontal 5-tap polyphase (8-phase) filters for luminance and chrominance.
- Can scale up to a maximum resolution of 2047 $\times$ 2047 (depends upon memory bandwidth available for the video scaling operation).
- Can scale up from a minimum resolution of 17 $\times$ 4.
- The maximum scale down ratio is 1:7.

### 2.6.3 DES Module

The BSP-15 DSP includes hardware support for encryption and decryption of data according to the *National Bureau of Standards Data Encryption Standard* and certain implementations thereof as defined in *FIPS Publications 46-2, 46-3, 74, and 81* and *ANSI Publication X9.52-1998*. For more information on this support, contact your Equator Technologies sales representative.

## 2.7 I/O Interfaces

The BSP-15 DSP has two modes of operation, digital RGB (dRGB) output mode and analog RGB (aRGB) output mode. The analog RGB mode is the primary I/O mode for most applications. In addition there is a second digital RGB video output mode used for driving LCD displays for use in PDA, video conferencing or other LCD applications.

### 2.7.1 Audio Interfaces

#### 2.7.1.1 IEC958 Audio Interface

This interface supports a multitude of audio, video, data and control interfaces:

- Sony/Philips Digital Interface (S/PDIF)
- Audio Engineering Society/European Broadcast Union (AES/EBU) interface
- TOSLINK interface (requires external IR devices)

The BSP-15 DSP's IEC958 interface can insert even or odd parity on each sub-frame of the output bit stream.

#### 2.7.1.2 IIS Interface

The Inter-IC Sound (IIS) interface drives high quality audio D/A converters for home theater. The BSP-15 DSP's interface meets the requirements of the standard serial data protocol and provides connection for up to three stereo DACs and one ADC. The interface supports 48 kHz, 44.1 kHz, and 32 kHz audio sample rates. Simultaneous input and output must be at the same sample rate. The BSP-15 DSP's IIS supports both master and slave mode interface. In slave mode there is the choice of using either external inputs or internally generated signals for the sample rate clock and serial bit clock.

### 2.7.2 Video Interfaces

The BSP-15 DSP provides two video input ports and one video output port. Each input port supports either transport channel interface input or ITU-R BT.601/656 input. The output port supports an ITU-R BT.601/656 compliant output.

In addition, the primary video input port and/or the output port can be used in a general purpose mode for transferring data (general purpose data port) for input or output respectively.

#### 2.7.2.1 Transport Channel Interfaces

The video input unit implements two DVB compliant transport channel interfaces which receive demodulated channel data in transport layer format. The transport channel interface (TCI) accepts MPEG-2 system transport packets in either byte parallel or, by default, bit serial form. Data rates up to 80 Mbps (serial) or 30 MBps (byte-wide parallel) are supported. By default, serial data is input on `tci_data[0]` and parallel data is input on `tci_data[7:0]` with bit 7 the most significant. These orientations can be reversed by PIO programming.

The TCI synchronizes packet data received in broadcast applications such as satellite or cable. The TCI can detect inline sync bytes, which are the first byte of every transport header. Alternatively, the TCI can utilize the external `tci_sync` signal. Once byte-sync has been detected, the TCI moves byte-aligned data into the BSP-15 DSP's memory using the DataStreamer DMA controller.

The number of bytes in each packet is programmable. At the end of every packet, the TCI appends an eight-byte postscript that includes time stamps from the local clock counters. This information can be

used in conjunction with the Program Clock References embedded in the transport stream to track the timing reference. This is accomplished by using a software loop filter to implement a 1-bit sigma-delta modulator to provide a controlling voltage for the external VCXO that drives `pc1k`. The sigma-delta data stream is output at 1.5 MHz on the `tci_vdac` pin via the primary TCI.

In addition to the local clock counters, there is a programmable 27 MHz timer in each TCI module that generates an interrupt on overflow (rollover).

### 2.7.2.2 ITU-656 Input Interface

This interface provides direct connection to an ITU-R BT.601/656 format NTSC/PAL video input decoder. The external decoder can be controlled using the IIC Serial Bus.

### 2.7.2.3 ITU-656 Output Interface

A glueless interface to a NTSC/PAL video encoder is provided, enabling the BSP-15 DSP to directly generate high-quality NTSC or PAL video-output signals. This interface supports 8-bit 525 and 625 line resolutions with either separate H/Vsync (ITU-R BT. 601) or inline sync (ITU-R BT.656). Advanced video post-filtering on the BSP-15 DSP via software can produce flicker-free output when converting interlace-to-progressive output. The external NTSC/PAL encoder can be controlled using the IIC Serial Bus.

### 2.7.2.4 General Purpose Data Port (GPDP)

The general purpose data port provides an 8-bit parallel input/output port. Together with a clock and a couple of handshake signals, this provides an alternative I/O port than just PCI for multiple MAP chips to communicate at higher inter-chip bandwidths. The GPDP data bandwidth supported is up to 60MB/s depending upon other system activity.

## 2.7.3 Display Refresh Controller

Sophisticated video blending, 2D graphics with alpha blending, PIP, and hardware cursor overlays for EPGs (Electronic Program Guides) and navigation services have been designed into the Display Refresh Controller. Color space conversion, Gamma correction, and choice of YCbCr or RGB output format is supported.

## 2.7.4 Analog RGB

The BSP-15 processor provides an analog RGB interfacing supporting resolutions up to 1280x1024. The BSP-15 DSP's RGB DACs (digital-to-analog converters) are part of the Display Refresh Controller block. The 8-bit DACs allow pixel clock rates up to 110 MHz. The BSP-15 DSP generates RS-343A compatible monitor signals into doubly-terminated 75  $\Omega$  load and is capable of driving standard SVGA monitors.

The full scale output level is determined by an external reference voltage  $V_{ref}$  at 1.235V and an external resistor  $R_{nominal} = 1117 \Omega$ . The full scale level can be adjusted by adjusting the resistor value.

The DACs output the three primary analog color signals – red video, green video and blue video – with the video sync information superimposed on the green video output. Also, separate `hsync` and `vsync` reference signals are provided.

## 2.7.5 Digital RGB

The BSP-15 processor provides a digital RGB interface that connects gluelessly to an active matrix flat panel display using a pixel depth of 12, 18, or 24 bits.

## 2.7.6 IIC Interface Unit

The Inter-IC (IIC) serial bus was originally developed by Philips to facilitate communications and control among integrated circuits in consumer electronics. Using this two-wire serial interface, the BSP-15 DSP can function as a master or slave device to relay status and control information to external devices.

The IIC interface unit has an additional output signal, `iic_select` that allows BSP-15 DSP's software to control an external analog multiplexer/level converter that can switch between a regular IIC bus and any other external bus (such as DDC for a monitor interface). This signal can also be used as a general purpose output.

## 2.7.7 ROM Controller

The ROM Controller (ROMCON) unit performs four distinct functions.

- The Chip Configuration and ROM Boot Sequencer is a state machine for reading chip configuration and boot code at system startup.
- The Flash ROM Interface controls the actual reading and writing of an off-chip flash ROM device.
- The Interrupt Controller/Collector provides a means for enabling, setting, and clearing hardware and software interrupts to the VLIW core and PCI bus controller.
- The PLL I/O provides PIO access to the programmable registers related to the various on-chip PLLs. The three PLLs for the core/SDRAM, pixel, and audio clocks are programmed indirectly via PIO registers within the ROMCON unit.

The purpose of the Configuration/Boot Sequencer is to control the boot up process of the chip. During reset, the resistor straps connected to the `ntsc_out_data[7:0]` pins are examined to determine how BSP-15 DSP will configure itself and boot. If the resistor straps indicate to boot from ROM, the Boot Sequencer directs the Flash ROM Interface Controller to transfer bytes from the external ROM device to the BSP-15 DSP's configuration registers and to the PCI configuration registers. The 6KB line buffer memory of the Video Filter is then used to store the bootstrap program for system boot up. ROMCON copies the next 6 KB from ROM into the Video Filter memory (VfMem) through an 8-bit configuration bus. After the boot code has been loaded, ROMCON uninstalls (restarts) the VLIW core, which in turn begins to execute the boot code out of VfMem. The ROMCON unit operates at 27 MHz during the configuration loading, since the core PLL cannot be programmed to be taken out of bypass mode until after the VLIW core has been uninstalled.

Alternatively, for booting via the PCI interface, ROMCON plays a mostly passive role. In this case, an external host loads the VfMem with boot code and initiates boot of the VLIW core via a PIO write to uninstalls the VLIW core.

ROMCON also runs power-on diagnostics during the boot and may be paused at various points for status testing. ROMCON requires minimal chip resources so that standard power-on diagnostics can run without having to bring up all portions of the chip, allowing the chip to be tested in more manageable stages.

## 2.7.8 Reset Strap

During reset, the eight `ntsc_out_data` pins are used as inputs to read pre-boot configuration settings. These are settings that must be known before the actual boot process begins – namely, whether the system should boot from ROM and whether PCI should serve as host for its bus. There are also four straps available whose meaning can be defined in software.

Each pin strap is pulled high (to `VddI/O`) or low (to `GND`) through a 4.7 K $\Omega$  resistor. The pins are sampled into flip-flops until reset is de-asserted and then saved in the software-visible `StrapBits` field of PIO register `ConfigBusControl`. For more information see Section 4.8.6, “Reset Straps,” on page 34.



# Chapter 3 BGA Pin-out Assignments

Signal assignment on the BGA352 package is shown here. Figure 3.1 shows the bottom view, with the balls facing the viewer. Figure 3.2 shows the top view of the chip with pin assignments.

In Table 3-1, pins marked with a (b) have multiple functions assigned (see Chapter 4 on page 25).

**Table 3-1 Pin Assignments**

| Signal Name      | Ball             | Signal Name | Ball | Signal Name    | Ball | Signal Name | Ball |
|------------------|------------------|-------------|------|----------------|------|-------------|------|
| audioclk_byp_in  | A2 <sup>a</sup>  | sddata[27]  | K24  | pci_ad[12]     | AF5  | Vddcore     | P4   |
| aVdd_PLL1        | B3               | sddqm[3]    | K26  | pci_ad[13]     | AF4  | Vddcore     | N4   |
| aVss             | C4               | sddata[28]  | L24  | pci_ad[14]     | AD6  | Vddcore     | M4   |
| aVdd_PLL1        | D5               | sddata[29]  | L25  | pci_ad[15]     | AF3  | Vddcore     | J4   |
| aVss             | A3               | sddata[30]  | M25  | pci_cbe_[1]    | AE4  | Vddcore     | G4   |
| pixelclk_byp_in  | B4 <sup>b</sup>  | sddata[31]  | M24  | pci_par        | AD5  | Vddcore     | F4   |
| ntsc_out_data[3] | C5 <sup>b</sup>  | sdcs#[0]    | M26  | pci_serr_intb# | AC6  | VddI/O      | C3   |
| ntsc_out_data[4] | B5 <sup>b</sup>  | sdcs#[1]    | N24  | pci_stop#      | AF2  | VddI/O      | D4   |
| ntsc_out_data[5] | A4 <sup>b</sup>  | sdcs#[2]    | N25  | pci_devsel#    | AE3  | VddI/O      | E4   |
| ntsc_out_data[6] | C6 <sup>b</sup>  | sdcs#[3]    | P26  | pci_trdy#      | AD4  | VddI/O      | D10  |
| ntsc_out_data[7] | D7 <sup>b</sup>  | sdrtnclk    | P24  | pci_irdy#      | AC5  | VddI/O      | D18  |
| video_ina[0]     | B6 <sup>b</sup>  | sdclk       | R25  | Vss            | AD2  | VddI/O      | C24  |
| video_ina[1]     | C7 <sup>b</sup>  | sdclk1      | R24  | Vddcore        | AE1  | VddI/O      | D23  |
| video_ina[2]     | D8 <sup>b</sup>  | sdclk2      | T26  | Vddcore        | AC3  | VddI/O      | F23  |
| video_ina[3]     | A6 <sup>b</sup>  | sdras#      | T25  | Vss            | AB3  | VddI/O      | J23  |
| video_ina[4]     | B7 <sup>b</sup>  | sdcas#      | T24  | pci_frame_     | AC2  | VddI/O      | L23  |
| video_ina[5]     | A7 <sup>b</sup>  | sdwe#       | U25  | pci_cbe_[2]    | AC1  | VddI/O      | N23  |
| video_ina[6]     | C8 <sup>b</sup>  | sdadr[0]    | U24  | pci_ad[16]     | AB1  | VddI/O      | R23  |
| video_ina[7]     | D9 <sup>b</sup>  | sdadr[1]    | V26  | pci_ad[17]     | AA2  | VddI/O      | U23  |
| video_ina[8]     | B8 <sup>b</sup>  | sdadr[2]    | V24  | pci_ad[18]     | AA3  | VddI/O      | Y23  |
| video_ina[9]     | C9 <sup>b</sup>  | sdadr[3]    | W25  | pci_ad[19]     | AA1  | VddI/O      | AD24 |
| tcia_inuse       | A8               | sdadr[4]    | Y26  | pci_ad[20]     | Y3   | VddI/O      | AC23 |
| tcia_sync        | A9               | sdadr[5]    | W24  | pci_ad[21]     | Y2   | VddI/O      | AC17 |
| tcia_clk         | C10              | sdadr[6]    | Y25  | pci_ad[22]     | W1   | VddI/O      | AC14 |
| tcia_vdac        | B10              | sdadr[7]    | Y24  | pci_ad[23]     | W2   | VddI/O      | AC13 |
| ntsc_ina_clk27   | A10 <sup>b</sup> | sdadr[8]    | AA25 | pci_idsel      | W3   | VddI/O      | AC10 |

**Table 3-1 Pin Assignments (Continued)**

| Signal Name     | Ball             | Signal Name    | Ball              | Signal Name      | Ball            | Signal Name | Ball |
|-----------------|------------------|----------------|-------------------|------------------|-----------------|-------------|------|
| video_inb[0]    | C11 <sup>b</sup> | sdadr[9]       | AA24              | pci_cbe[3]       | V1              | VddI/O      | AD3  |
| video_inb[1]    | B11 <sup>b</sup> | sdadr[10]      | AB26              | pci_ad[24]       | V3              | VddI/O      | AC4  |
| video_inb[2]    | A11 <sup>b</sup> | sdadr[11]      | AD26              | pci_ad[25]       | U1              | VddI/O      | Y4   |
| video_inb[3]    | D12 <sup>b</sup> | sdadr[12]      | AB24              | pci_ad[26]       | U4              | VddI/O      | V4   |
| video_inb[4]    | C12 <sup>b</sup> | sdadr[13]      | AD25              | pci_ad[27]       | U3              | VddI/O      | R4   |
| video_inb[5]    | B12 <sup>b</sup> | sddata[32]     | AC24              | pci_ad[28]       | U2              | VddI/O      | L4   |
| video_inb[6]    | A13 <sup>b</sup> | sddata[33]     | AB23              | pci_ad[29]       | T3              | VddI/O      | H4   |
| video_inb[7]    | C13 <sup>b</sup> | aVss           | AC22              | pci_ad[30]       | T2              | Vss         | A1   |
| video_inb[8]    | D13 <sup>b</sup> | aVss           | AD23              | pci_ad[31]       | R3              | Vss         | B1   |
| video_inb[9]    | B13 <sup>b</sup> | aVdd_PLL2      | AE24              | pci_req#[0]      | R2              | Vss         | B2   |
| tcib_inuse      | A14              | aVdd_PLL2      | AF25              | pci_req#[1]      | R1              | Vss         | A5   |
| tcib_sync       | B14              | sdelk_byp_in   | AC21 <sup>b</sup> | pci_req#[2]      | P3              | Vss         | B9   |
| tcib_clk        | C14              | pclk           | AD22 <sup>c</sup> | pci_gnt#[0]      | P1              | Vss         | A12  |
| ntsc_inb_clk27  | D14              | coreclk_byp_in | AE23 <sup>b</sup> | pci_gnt#[1]      | N1              | Vss         | A15  |
| vsync           | A16              | pci_clk        | AF24              | pci_gnt#[2]      | N2              | Vss         | B18  |
| hsync           | B15              | sddata[34]     | AD21              | pclk_out         | N3 <sup>d</sup> | Vss         | A22  |
| tms             | B16              | sddata[35]     | AF23              | pci_rst#         | M2              | Vss         | A26  |
| trst            | C15              | sddqm[4]       | AF22              | pci_inta#        | M3              | Vss         | B25  |
| aVss            | A17              | sddata[36]     | AE21              | pci_pme#         | L1              | Vss         | C26  |
| gdac_fscale     | B17              | sddata[37]     | AC19              | iic_sda          | L2              | Vss         | E26  |
| gdac_comp       | C16              | sddata[38]     | AD20              | iic_sck          | L3              | Vss         | F25  |
| aVdd_DAC        | D16              | sddata[39]     | AF21              | iic_select       | K1              | Vss         | G26  |
| gdac_green      | C17              | sddata[40]     | AF20              | iis_in_data      | K3              | Vss         | J26  |
| gdac_blue       | A18              | sddata[41]     | AC18              | iis_in_lr        | J1              | Vss         | K25  |
| gdac_red        | A19              | sddata[42]     | AD19              | iis_in_bclk      | K4              | Vss         | L26  |
| gdac_cvgg(aVss) | C18              | sddata[43]     | AE19              | iis_out_data[0]  | J2 <sup>b</sup> | Vss         | N26  |
| aVddx           | D17              | sddqm[5]       | AD18              | iis_out_data[1]  | J3 <sup>b</sup> | Vss         | P25  |
| aVssx           | B19              | sddata[44]     | AF19              | iis_out_data[2]  | H2 <sup>b</sup> | Vss         | R26  |
| tdi             | A20              | sddata[45]     | AE18              | iis_out_lr       | G1              | Vss         | U26  |
| tck             | B20              | sddata[46]     | AD17              | iis_out_bclk     | H3              | Vss         | V25  |
| tdo             | C19              | sddata[47]     | AE17              | iec958_in        | G2              | Vss         | W26  |
| no connection   | A21              | sddata[48]     | AF17              | iec958_out       | G3              | Vss         | AA26 |
| sddata[0]       | B21              | sddata[49]     | AD16              | rom_cs#          | F1              | Vss         | AB25 |
| sddata[1]       | C20              | sddata[50]     | AF16              | ntsc_out_hsync   | F3 <sup>b</sup> | Vss         | AC26 |
| sddata[2]       | D19              | sddata[51]     | AC15              | ntsc_out_vsync   | E1 <sup>b</sup> | Vss         | AC25 |
| sddata[3]       | A23              | sddqm[6]       | AD15              | ntsc_out_data[0] | E2 <sup>b</sup> | Vss         | AE26 |
| sddqm[0]        | B22              | sddata[52]     | AE15              | ntsc_out_data[1] | E3 <sup>b</sup> | Vss         | AE25 |



**Table 3-1 Pin Assignments (Continued)**

| Signal Name | Ball | Signal Name | Ball | Signal Name      | Ball            | Signal Name | Ball |
|-------------|------|-------------|------|------------------|-----------------|-------------|------|
| sddata[4]   | C21  | sddata[53]  | AF15 | ntsc_out_data[2] | C1 <sup>b</sup> | Vss         | AF26 |
| sddata[5]   | A24  | sddata[54]  | AD14 | audioclk_out     | C2              | Vss         | AE22 |
| sddata[6]   | B23  | sddata[55]  | AE14 | pixelclk_out     | D3 <sup>e</sup> | Vss         | AE20 |
| sddata[7]   | C22  | sddata[56]  | AF13 | Vddcore          | D6              | Vss         | AF18 |
| sddata[8]   | D21  | sddata[57]  | AD13 | Vddcore          | D11             | Vss         | AE16 |
| sddata[9]   | A25  | sddata[58]  | AF12 | Vddcore          | D15             | Vss         | AF14 |
| sddata[10]  | B24  | sddata[59]  | AE12 | Vddcore          | D20             | Vss         | AE13 |
| sddata[11]  | C23  | sddqm[7]    | AD12 | Vddcore          | E23             | Vss         | AE11 |
| sddqm[1]    | D22  | sddata[60]  | AC12 | Vddcore          | G23             | Vss         | AF9  |
| sddata[12]  | D24  | sddata[61]  | AF11 | Vddcore          | H23             | Vss         | AE7  |
| sddata[13]  | B26  | sddata[62]  | AD11 | Vddcore          | K23             | Vss         | AE5  |
| sddata[14]  | C25  | sddata[63]  | AF10 | Vddcore          | M23             | Vss         | AF1  |
| sddata[15]  | E24  | pci_ad[0]   | AE10 | Vddcore          | P23             | Vss         | AE2  |
| sddata[16]  | D25  | pci_ad[1]   | AD10 | Vddcore          | T23             | Vss         | AD1  |
| sddata[17]  | D26  | pci_ad[2]   | AE9  | Vddcore          | V23             | Vss         | AB2  |
| sddata[18]  | E25  | pci_ad[3]   | AF8  | Vddcore          | W23             | Vss         | Y1   |
| sddata[19]  | F24  | pci_ad[4]   | AD9  | Vddcore          | AA23            | Vss         | V2   |
| sddqm[2]    | F26  | pci_ad[5]   | AE8  | Vddcore          | AC20            | Vss         | T1   |
| sddata[20]  | G24  | pci_ad[6]   | AC9  | Vddcore          | AC16            | Vss         | P2   |
| sddata[21]  | G25  | pci_ad[7]   | AD8  | Vddcore          | AC11            | Vss         | M1   |
| sddata[22]  | H25  | pci_cbe_[0] | AF7  | Vddcore          | AC7             | Vss         | K2   |
| sddata[23]  | H24  | pci_ad[8]   | AF6  | Vddcore          | AB4             | Vss         | H1   |
| sddata[24]  | H26  | pci_ad[9]   | AD7  | Vddcore          | AA4             | Vss         | F2   |
| sddata[25]  | J24  | pci_ad[10]  | AC8  | Vddcore          | W4              | Vss         | D1   |
| sddata[26]  | J25  | pci_ad[11]  | AE6  | Vddcore          | T4              | Vss         | D2   |

- a. If unused, NCi (Vss) and tie to ground
- b. connect to 27 MHz or lower clock
- c. connect to 27 MHz clock
- d. If unused, NCo and floating
- e. Leave floating

|    | 26          | 25            | 24            | 23                 | 22          | 21                 | 20          | 19           | 18             | 17            | 16           | 15          | 14                  | 13               | 12               | 11               | 10                   | 9                | 8                | 7                       | 6                       | 5               | 4                       | 3               | 2                   | 1               |
|----|-------------|---------------|---------------|--------------------|-------------|--------------------|-------------|--------------|----------------|---------------|--------------|-------------|---------------------|------------------|------------------|------------------|----------------------|------------------|------------------|-------------------------|-------------------------|-----------------|-------------------------|-----------------|---------------------|-----------------|
| A  | Vss         | sddana [9]    | sddana [5]    | sddana [3]         | Vss         | no con-<br>nection | tdi         | gdc-<br>red  | gdc-<br>blue   | Vss           | vsync        | Vss         | tech-<br>inuse      | video-<br>hnb[6] | Vss              | video-<br>hnb[2] | nsc-<br>hnci-<br>k27 | tea-<br>sync     | tea-<br>inuse    | video-<br>hnb[5]        | video-<br>hnb[3]        | Vss             | nsc-<br>out-<br>data[5] | Vss             | autofork-<br>byp_in | Vss             |
| B  | sddana [13] | Vss           | sddana [10]   | sddana [6]         | sddana [0]  | tek                | Vss         | gdc-<br>aVss | gdc-<br>fscube | gdc-<br>green | ins-<br>comp | hsync       | tech-<br>clk        | video-<br>hnb[7] | video-<br>hnb[5] | video-<br>hnb[1] | video-<br>hnb[8]     | video-<br>hnb[9] | video-<br>hnb[4] | nsc-<br>out-<br>data[4] | nsc-<br>out-<br>data[3] | Vss             | autofork-<br>out        | Vss             | autofork-<br>byp_in | Vss             |
| C  | Vss         | sddana [14]   | VddIO         | sddana [11]        | sddana [7]  | sddana [4]         | tdo         | gdc-<br>aVss | gdc-<br>green  | gdc-<br>comp  | ins-<br>comp | hsync       | tech-<br>clk        | video-<br>hnb[7] | video-<br>hnb[4] | video-<br>hnb[0] | video-<br>hnb[9]     | video-<br>hnb[8] | video-<br>hnb[4] | nsc-<br>out-<br>data[6] | nsc-<br>out-<br>data[3] | VddIO           | autofork-<br>out        | Vss             | autofork-<br>out    | Vss             |
| D  | sddana [17] | sddana [16]   | sddana [15]   | VddIO              | sddana [11] | sddana [8]         | VddIO       | aVdd         | VddIO          | aVdd-<br>DAC  | Vddcore      | Vddcore     | nsc-<br>hnb-<br>k27 | video-<br>hnb[8] | video-<br>hnb[5] | video-<br>hnb[0] | video-<br>hnb[9]     | video-<br>hnb[8] | video-<br>hnb[4] | nsc-<br>out-<br>data[6] | nsc-<br>out-<br>data[3] | aVdd            | VddIO                   | pixclk-<br>out  | Vss                 | Vss             |
| E  | Vss         | sddana [18]   | sddana [15]   | Vddcore            | VddIO       | Vddcore            | VddIO       | VddIO        | VddIO          | Vddcore       | Vddcore      | Vddcore     | Vddcore             | video-<br>hnb[7] | video-<br>hnb[5] | video-<br>hnb[0] | video-<br>hnb[9]     | video-<br>hnb[8] | video-<br>hnb[4] | nsc-<br>out-<br>data[6] | nsc-<br>out-<br>data[3] | aVdd            | VddIO                   | pixclk-<br>out  | Vss                 | Vss             |
| F  | sddana [21] | Vss           | sddana [19]   | VddIO              | VddIO       | VddIO              | VddIO       | VddIO        | VddIO          | Vddcore       | Vddcore      | Vddcore     | Vddcore             | video-<br>hnb[7] | video-<br>hnb[5] | video-<br>hnb[0] | video-<br>hnb[9]     | video-<br>hnb[8] | video-<br>hnb[4] | nsc-<br>out-<br>data[6] | nsc-<br>out-<br>data[3] | aVdd            | VddIO                   | pixclk-<br>out  | Vss                 | Vss             |
| G  | Vss         | sddana [21]   | sddana [20]   | Vddcore            | Vddcore     | Vddcore            | Vddcore     | Vddcore      | Vddcore        | Vddcore       | Vddcore      | Vddcore     | Vddcore             | video-<br>hnb[7] | video-<br>hnb[5] | video-<br>hnb[0] | video-<br>hnb[9]     | video-<br>hnb[8] | video-<br>hnb[4] | nsc-<br>out-<br>data[6] | nsc-<br>out-<br>data[3] | aVdd            | VddIO                   | pixclk-<br>out  | Vss                 | Vss             |
| H  | sddana [24] | sddana [22]   | sddana [23]   | Vddcore            | Vddcore     | Vddcore            | Vddcore     | Vddcore      | Vddcore        | Vddcore       | Vddcore      | Vddcore     | Vddcore             | video-<br>hnb[7] | video-<br>hnb[5] | video-<br>hnb[0] | video-<br>hnb[9]     | video-<br>hnb[8] | video-<br>hnb[4] | nsc-<br>out-<br>data[6] | nsc-<br>out-<br>data[3] | aVdd            | VddIO                   | pixclk-<br>out  | Vss                 | Vss             |
| J  | Vss         | sddana [26]   | sddana [25]   | VddIO              | VddIO       | VddIO              | VddIO       | VddIO        | VddIO          | Vddcore       | Vddcore      | Vddcore     | Vddcore             | video-<br>hnb[7] | video-<br>hnb[5] | video-<br>hnb[0] | video-<br>hnb[9]     | video-<br>hnb[8] | video-<br>hnb[4] | nsc-<br>out-<br>data[6] | nsc-<br>out-<br>data[3] | aVdd            | VddIO                   | pixclk-<br>out  | Vss                 | Vss             |
| K  | sddana [31] | Vss           | sddana [27]   | Vddcore            | Vddcore     | Vddcore            | Vddcore     | Vddcore      | Vddcore        | Vddcore       | Vddcore      | Vddcore     | Vddcore             | video-<br>hnb[7] | video-<br>hnb[5] | video-<br>hnb[0] | video-<br>hnb[9]     | video-<br>hnb[8] | video-<br>hnb[4] | nsc-<br>out-<br>data[6] | nsc-<br>out-<br>data[3] | aVdd            | VddIO                   | pixclk-<br>out  | Vss                 | Vss             |
| L  | Vss         | sddana [29]   | sddana [28]   | VddIO              | VddIO       | VddIO              | VddIO       | VddIO        | VddIO          | Vddcore       | Vddcore      | Vddcore     | Vddcore             | video-<br>hnb[7] | video-<br>hnb[5] | video-<br>hnb[0] | video-<br>hnb[9]     | video-<br>hnb[8] | video-<br>hnb[4] | nsc-<br>out-<br>data[6] | nsc-<br>out-<br>data[3] | aVdd            | VddIO                   | pixclk-<br>out  | Vss                 | Vss             |
| M  | sdc-<br>[0] | sddana [30]   | sddana [31]   | Vddcore            | Vddcore     | Vddcore            | Vddcore     | Vddcore      | Vddcore        | Vddcore       | Vddcore      | Vddcore     | Vddcore             | video-<br>hnb[7] | video-<br>hnb[5] | video-<br>hnb[0] | video-<br>hnb[9]     | video-<br>hnb[8] | video-<br>hnb[4] | nsc-<br>out-<br>data[6] | nsc-<br>out-<br>data[3] | aVdd            | VddIO                   | pixclk-<br>out  | Vss                 | Vss             |
| N  | Vss         | sdc-<br>[2]   | sdc-<br>[1]   | VddIO              | VddIO       | VddIO              | VddIO       | VddIO        | VddIO          | Vddcore       | Vddcore      | Vddcore     | Vddcore             | video-<br>hnb[7] | video-<br>hnb[5] | video-<br>hnb[0] | video-<br>hnb[9]     | video-<br>hnb[8] | video-<br>hnb[4] | nsc-<br>out-<br>data[6] | nsc-<br>out-<br>data[3] | aVdd            | VddIO                   | pixclk-<br>out  | Vss                 | Vss             |
| P  | sdc-<br>[3] | Vss           | sdrnck        | Vddcore            | Vddcore     | Vddcore            | Vddcore     | Vddcore      | Vddcore        | Vddcore       | Vddcore      | Vddcore     | Vddcore             | video-<br>hnb[7] | video-<br>hnb[5] | video-<br>hnb[0] | video-<br>hnb[9]     | video-<br>hnb[8] | video-<br>hnb[4] | nsc-<br>out-<br>data[6] | nsc-<br>out-<br>data[3] | aVdd            | VddIO                   | pixclk-<br>out  | Vss                 | Vss             |
| R  | Vss         | sdc[k]        | sdc[k]        | VddIO              | VddIO       | VddIO              | VddIO       | VddIO        | VddIO          | Vddcore       | Vddcore      | Vddcore     | Vddcore             | video-<br>hnb[7] | video-<br>hnb[5] | video-<br>hnb[0] | video-<br>hnb[9]     | video-<br>hnb[8] | video-<br>hnb[4] | nsc-<br>out-<br>data[6] | nsc-<br>out-<br>data[3] | aVdd            | VddIO                   | pixclk-<br>out  | Vss                 | Vss             |
| T  | sdc[k2]     | sdc[k#]       | sdc[k#]       | Vddcore            | Vddcore     | Vddcore            | Vddcore     | Vddcore      | Vddcore        | Vddcore       | Vddcore      | Vddcore     | Vddcore             | video-<br>hnb[7] | video-<br>hnb[5] | video-<br>hnb[0] | video-<br>hnb[9]     | video-<br>hnb[8] | video-<br>hnb[4] | nsc-<br>out-<br>data[6] | nsc-<br>out-<br>data[3] | aVdd            | VddIO                   | pixclk-<br>out  | Vss                 | Vss             |
| U  | Vss         | sdcw#         | sdc[k#]       | VddIO              | VddIO       | VddIO              | VddIO       | VddIO        | VddIO          | Vddcore       | Vddcore      | Vddcore     | Vddcore             | video-<br>hnb[7] | video-<br>hnb[5] | video-<br>hnb[0] | video-<br>hnb[9]     | video-<br>hnb[8] | video-<br>hnb[4] | nsc-<br>out-<br>data[6] | nsc-<br>out-<br>data[3] | aVdd            | VddIO                   | pixclk-<br>out  | Vss                 | Vss             |
| V  | sdc[k1]     | Vss           | sdc[k2]       | Vddcore            | Vddcore     | Vddcore            | Vddcore     | Vddcore      | Vddcore        | Vddcore       | Vddcore      | Vddcore     | Vddcore             | video-<br>hnb[7] | video-<br>hnb[5] | video-<br>hnb[0] | video-<br>hnb[9]     | video-<br>hnb[8] | video-<br>hnb[4] | nsc-<br>out-<br>data[6] | nsc-<br>out-<br>data[3] | aVdd            | VddIO                   | pixclk-<br>out  | Vss                 | Vss             |
| W  | Vss         | sdc[k3]       | sdc[k5]       | Vddcore            | Vddcore     | Vddcore            | Vddcore     | Vddcore      | Vddcore        | Vddcore       | Vddcore      | Vddcore     | Vddcore             | video-<br>hnb[7] | video-<br>hnb[5] | video-<br>hnb[0] | video-<br>hnb[9]     | video-<br>hnb[8] | video-<br>hnb[4] | nsc-<br>out-<br>data[6] | nsc-<br>out-<br>data[3] | aVdd            | VddIO                   | pixclk-<br>out  | Vss                 | Vss             |
| Y  | sdc[k4]     | sdc[k6]       | sdc[k7]       | VddIO              | VddIO       | VddIO              | VddIO       | VddIO        | VddIO          | Vddcore       | Vddcore      | Vddcore     | Vddcore             | video-<br>hnb[7] | video-<br>hnb[5] | video-<br>hnb[0] | video-<br>hnb[9]     | video-<br>hnb[8] | video-<br>hnb[4] | nsc-<br>out-<br>data[6] | nsc-<br>out-<br>data[3] | aVdd            | VddIO                   | pixclk-<br>out  | Vss                 | Vss             |
| AA | Vss         | sdc[k8]       | sdc[k9]       | Vddcore            | Vddcore     | Vddcore            | Vddcore     | Vddcore      | Vddcore        | Vddcore       | Vddcore      | Vddcore     | Vddcore             | video-<br>hnb[7] | video-<br>hnb[5] | video-<br>hnb[0] | video-<br>hnb[9]     | video-<br>hnb[8] | video-<br>hnb[4] | nsc-<br>out-<br>data[6] | nsc-<br>out-<br>data[3] | aVdd            | VddIO                   | pixclk-<br>out  | Vss                 | Vss             |
| AB | sdc[k10]    | Vss           | sdc[k11]      | Vddcore            | Vddcore     | Vddcore            | Vddcore     | Vddcore      | Vddcore        | Vddcore       | Vddcore      | Vddcore     | Vddcore             | video-<br>hnb[7] | video-<br>hnb[5] | video-<br>hnb[0] | video-<br>hnb[9]     | video-<br>hnb[8] | video-<br>hnb[4] | nsc-<br>out-<br>data[6] | nsc-<br>out-<br>data[3] | aVdd            | VddIO                   | pixclk-<br>out  | Vss                 | Vss             |
| AC | Vss         | Vss           | sdc[k12]      | VddIO              | VddIO       | VddIO              | VddIO       | VddIO        | VddIO          | Vddcore       | Vddcore      | Vddcore     | Vddcore             | video-<br>hnb[7] | video-<br>hnb[5] | video-<br>hnb[0] | video-<br>hnb[9]     | video-<br>hnb[8] | video-<br>hnb[4] | nsc-<br>out-<br>data[6] | nsc-<br>out-<br>data[3] | aVdd            | VddIO                   | pixclk-<br>out  | Vss                 | Vss             |
| AD | sdc[k11]    | sdc[k13]      | VddIO         | Vss                | pk[k]       | sddana [34]        | sddana [38] | sddana [42]  | sddana [5]     | sddana [46]   | sddana [49]  | sddana [6]  | sddana [54]         | sddana [57]      | sddana [7]       | sddana [62]      | pci-<br>ad [4]       | pci-<br>ad [7]   | pci-<br>ad [4]   | pci-<br>ad [14]         | pci-<br>ad [14]         | pci-<br>ad [12] | pci-<br>ad [11]         | pci-<br>ad [11] | pci-<br>ad [11]     | pci-<br>ad [11] |
| AE | Vss         | Vss           | aVdd-<br>PLL2 | coreclk-<br>byp_in | Vss         | sddana [36]        | sddana [40] | sddana [44]  | sddana [45]    | sddana [47]   | Vss          | sddana [52] | sddana [55]         | sddana [59]      | sddana [61]      | sddana [62]      | pci-<br>ad [0]       | pci-<br>ad [2]   | pci-<br>ad [5]   | pci-<br>ad [9]          | pci-<br>ad [11]         | pci-<br>ad [12] | pci-<br>ad [13]         | pci-<br>ad [15] | pci-<br>ad [15]     | pci-<br>ad [15] |
| AF | Vss         | aVdd-<br>PLL2 | pci-<br>clk   | sddana [35]        | sddana [4]  | sddana [39]        | sddana [40] | sddana [44]  | sddana [48]    | sddana [50]   | sddana [53]  | sddana [53] | Vss                 | sddana [56]      | sddana [58]      | sddana [61]      | sddana [63]          | pci-<br>ad [3]   | pci-<br>ad [8]   | pci-<br>ad [10]         | pci-<br>ad [18]         | pci-<br>ad [18] | pci-<br>ad [12]         | pci-<br>ad [13] | pci-<br>ad [15]     | pci-<br>ad [15] |

Figure 3.1 BSP-15 DSP pins viewed from bottom

Downloaded from Elcodis.com electronic components distributor





# Chapter 4 Signal Descriptions

## 4.1 Interface Summary

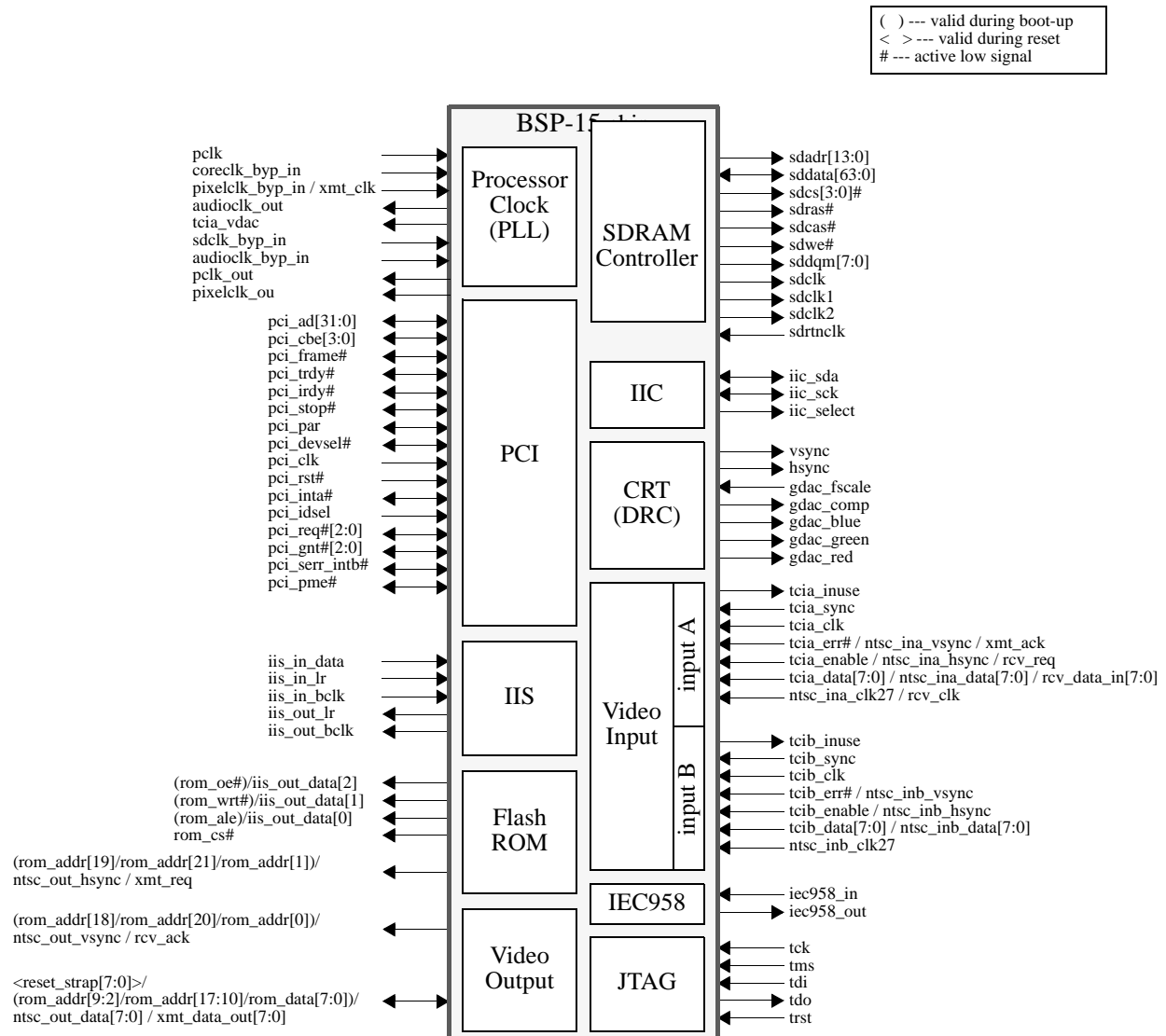

Figure 4.1 BSP-15 Interface

## 4.2 Legend

- A..... analog signal  
 B..... bi-directional  
 I..... input  
 O..... output  
 od..... open drain or active pull down  
 trailing “#” ..... active low  
 ()..... parentheses indicate number of shared signal pins

## 4.3 Processor Clock

There is a single 27 MHz reference clock signal for generating internal clocks.

**Table 4-1 Processor clock signal description**

| Signal                    | # of Pins | I/O | Description  |
|---------------------------|-----------|-----|--|
| pclk                      | 1         | I   | 27 MHz VCXO input that serves as the reference signal to the three on-chip PLLs. It is also a reference clock for the video output and the IIC interface |
| coreclk_byp_in            | 1         | I   | Bypass input for the core clock  |
| sdclk_byp_in              | 1         | I   | Bypass input for the SDRAM clock.  |
| pixelclk_byp_in           | 1         | I   | Transmit clock for GPDP (xmt_clk) or PLL-bypass input for pixel clock  |
| audioclk_byp_in           | 1         | I   | Bypass input for the audio clock.  |
| pclk_out<br>(coreclk_out) | 1         | O   | Output for the core clock.   |
| pixelclk_out              | 1         | O   | Output for the pixel clock.  |
| audioclk_out              | 1         | O   | Audio clock output used for IIS interface master MCLK  |
| tcia_vdac                 | 1         | O   | Sigma-delta output from software loop filter for controlling external VCXO for pclk  |
| TOTAL                     | 9         |     |  |

## 4.4 SDRAM

The BSP-15 DSP supports either a SDRAM or SGRAM memory system using the signals shown in Table 4-2. The BSP-15 DSP supports a memory system of 64-bit or 32-bit data width. The BSP-15 DSP supports DRAM widths of 8-bit, 16-bit or 32-bits.

**Table 4-2 Memory interface signals**

| Signal                | # of Pins | I/O | Description   |
|-----------------------|-----------|-----|---|
| sdadr[13:0]           | 14        | O   | Address lines indicate row addresses when sdras_ is active and indicate column addresses when sdcas_ is active  |
| sddata[63:0]          | 64        | B   | Data Input/Output lines transfer data between the memory and BSP-15 DSP. These are also input mask bits for Write-per-Bit. When block write is activated, these lines provide column address mask |
| sdc*_[3:0]            | 4         | O   | Chip Select signal lines indicate that the command on the output lines is for each memory chip. If this signal is high, the output command(s) will be ignored by each corresponding memory chip   |
| sdras#                | 1         | O   | sdras_ is part of the output command to the SDRAM/SGRAM   |
| sdcas#                | 1         | O   | sdcas_ is part of the output command to the SDRAM/SGRAM   |
| sdwe#                 | 1         | O   | Write enable (sdwe_) is part of the output command  |
| sddqm[7:0]            | 8         | O   | During read, sddqm = 1 turns off the output buffers of SDRAM/SGRAM. During write, sddqm = 1 prevents a write to the current memory location   |
| sdclk, sdclk1, sdclk2 | 3         | O   | sdclk, sdclk1, and sdclk2 are driven by the BSP-15 DSP's SDRAM clock. All SDRAM/SGRAM input signals are sampled on the positive edge of sdclk   |
| sdrtnclk              | 1         | I   | sdrtnclk is driven by sdclk. This signal is used for latching the data from SDRAM/SGRAM   |
| TOTAL                 | 97        |     |   |

## 4.5 PCI Bus

The BSP-15 DSP provides the PCI bus as the primary system interface. 4-3 lists the PCI signals.

**Table 4-3 PCI interface signals**

| Signal       | # of Pins | I/O | Description  |
|--------------|-----------|-----|--|
| pci_ad[31:0] | 32        | B   | PCI multiplexed address and data lines. The address is driven when pci_frame_ is first asserted. Data is transferred on this bus in subsequent clocks.                                   |
| pci_cbe[3:0] | 4         | B   | For PCI cycles, the bus command and byte enables are used to transfer the PCI command during the address phase and are used to transfer byte lane enables during subsequent data phases. |

**Table 4-3 PCI interface signals**

| Signal        | # of Pins | I/O    | Description  |
|---------------|-----------|--------|--|
| pci_frame#    | 1         | B      | Transaction framing for PCI transfers. The initial assertion indicates the address phase and the start of a PCI transaction. Continued assertion determines the burst size of the transaction.   |
| pci_trdy#     | 1         | B      | The target ready signal is asserted when the PCI target is ready for a data transfer.  |
| pci_irdy#     | 1         | B      | The initiator ready signal is asserted when the PCI master is ready for a data transfer.   |
| pci_stop#     | 1         | B      | pci_stop_ is asserted by the target to request the master to stop the current transaction.   |
| pci_par       | 1         | B      | A single parity bit is calculated over pci_ad[31:0], and pci_c_be[3:0] and transferred over this signal.   |
| pci_devsel#   | 1         | B      | A target asserts the pci_devsel_ signal line to indicate it has decoded the address on the pci_ad[31:0] bus and will participate in (claim) the current transaction. The PCI bus master must monitor the pci_devsel_ signal line to determine if a target bus has claimed the transaction or if it will execute a Master Abort termination. pci_devsel_ will be tri-stated from the leading edge of pci_rst_. pci_devsel_ remains tri-stated until driven by the target. |
| pci_clk       | 1         | I      | pci_clk provides timing for all PCI transactions on the PCI bus. All other PCI signals are sampled on the rising edge of pci_clk, and all timing parameters are defined with respect to this edge.<br><b>NOTE:</b> The BSP-15 DSP's core clock PLL does not use this clock as a core PLL reference clock.  |
| pci_rst#      | 1         | I      | This signal indicates a reset of all PCI resources. In addition, the internal BSP-15 DSP core, etc. are reset by the assertion of this signal. PCI pad cell drivers are disabled by the assertion of this signal, as specified in the PCI 2.1 document.  |
| pci_inta#     | 1         | B (od) | When the BSP-15 DSP is not designated as the PCI bus "HOST", then this signal is the open drain output generating an asynchronous level sensitive interrupt on the PCI bus. The BSP-15 DSP pad cell does <u>not</u> contain a pull up for this signal.<br>When the BSP-15 DSP is designated as the PCI bus "HOST" then this signal is an interrupt request input from PCI devices. The BSP-15 DSP sees and utilizes this interrupt.                                      |
| pci_idsel     | 1         | I      | The initialization device select is used as a slot addressed chip select input during configuration read and write transactions. This signal is inactive in a self-hosted configuration.   |
| pci_req#[2:0] | 3         | B      | The assertion of pci_req_ in a non-self-hosted configuration indicates that the BSP-15 DSP desires the use of the PCI bus.   |
| pci_gnt#[2:0] | 3         | B      | The assertion of pci_gnt_ in a non-self-hosted environment indicates that the BSP-15 DSP has been granted the use of the PCI bus.  |



**Table 4-3 PCI interface signals**

| Signal         | # of Pins | I/O    | Description  |
|----------------|-----------|--------|--|
| pci_serr_intb# | 1         | B (od) | This open drain output may generate either an asynchronous level sensitive interrupt or the PCI bus or optionally signal SYSTEM ERROR. See the BSP-15 DSP configuration control register for the signal's current use.<br>When the BSP-15 DSP is not designated as the PCI bus "HOST", then this signal is the open drain output generating an asynchronous level sensitive interrupt on the PCI bus. The BSP-15 DSP's pad cell does <u>not</u> contain a pull up for this signal.<br>When the BSP-15 DSP is designated as the PCI bus "HOST", then this signal is an interrupt request input from PCI devices. The BSP-15 DSP sees and utilizes this interrupt. |
| pci_pme#       | 1         | B (od) | When BSP-15 DSP is not in PCI host mode, this signal is an open drain output used to request a change in power management state.<br>When BSP-15 DSP is in PCI host mode, this is an input signal to which PCI devices indicate changes in power management state.  |
| TOTAL          | 54        |        |  |

## 4.6 IEC958

The BSP-15 DSP provides an IEC958 interface as shown in Table 4-4.

**Table 4-4 IEC958 interface signals**

| Signal     | # of Pins | I/O | Description                                  |
|------------|-----------|-----|--|
| iec958_in  | 1         | I   | Serial input line for IEC958 digital audio.  |
| iec958_out | 1         | O   | Serial output line for IEC958 digital audio. |
| TOTAL      | 2         |     |  |

## 4.7 IIS

The BSP-15 DSP provides interfaces for IIS digital audio input and output as shown in Table 4-5.

**Table 4-5 IIS interface signals**

| Signal      | # of Pins | I/O | Description   |
|-------------|-----------|-----|---|
| iis_in_data | 1         | I   | Serial data input   |
| iis_in_lr   | 1         | I   | Select left/right channel in the serial input   |
| iis_in_bclk | 1         | I   | IIS input bit clock   |
| tcia_vdac   | 1         | O   | Serial output data (1 stereo channel)<br>Requires IIS bypass mode to be activated and and disables channel 1 and 2. |

**Table 4-5 IIS interface signals**

| Signal             | # of Pins | I/O | Description   |
|--------------------|-----------|-----|---|
| iis_out_data[2:0]  | 3         | O   | Serial output data (3 stereo channels)              |
| iis_out_lr         | 1         | O   | Select left/right channel in serial output channels |
| iis_out_bclk       | 1         | O   | IIS output bit-rate clock                           |
| TOTAL <sup>a</sup> | 8         |     |   |

a. audioclk\_out, defined in Section 4.3 on page 26, serves as the output MCLK in master mode.

## 4.8 Multi-Function Signal Pins

Table 4-6 lists the pin name and pin number of the shared pins on the BSP-15 DSP, along with the signal name associated with each mode-specific function.

**Table 4-6 Multiple Signal Pins**

| Ball # | Pin Name        | ITU-656 Mode     | TCI Mode     | GPDP Mode      | dRGB Mode | ROM Boot Mode | Reset Mode |
|--------|-----------------|------------------|--------------|----------------|-----------|---------------|------------|
| B4     | pixelclk_byp_in | -                | -            | xmt_clk        |           | -             | -          |
| B6     | video_ina[0]    | ntsc_ina_data[0] | tcia_data[0] | rcv_data_in[0] | dRGB12.G4 | -             | -          |
| C7     | video_ina[1]    | ntsc_ina_data[1] | tcia_data[1] | rcv_data_in[1] | dRGB12.G5 | -             | -          |
| D8     | video_ina[2]    | ntsc_ina_data[2] | tcia_data[2] | rcv_data_in[2] | dRGB12.G6 | -             | -          |
| A6     | video_ina[3]    | ntsc_ina_data[3] | tcia_data[3] | rcv_data_in[3] | dRGB12.G7 | -             | -          |
| B7     | video_ina[4]    | ntsc_ina_data[4] | tcia_data[4] | rcv_data_in[4] | dRGB12.R4 | -             | -          |
| A7     | video_ina[5]    | ntsc_ina_data[5] | tcia_data[5] | rcv_data_in[5] | dRGB12.R5 | -             | -          |
| C8     | video_ina[6]    | ntsc_ina_data[6] | tcia_data[6] | rcv_data_in[6] | dRGB12.R6 | -             | -          |
| D9     | video_ina[7]    | ntsc_ina_data[7] | tcia_data[7] | rcv_data_in[7] | dRGB12.R7 | -             | -          |
| B8     | video_ina[8]    | ntsc_ina_hsync   | tcia_enable  | rcv_req        | dRGB18.B2 | -             | -          |
| C9     | video_ina[9]    | ntsc_ina_vsync   | tcia_err#    | xmt_ack        | dRGB18.B3 | -             | -          |
| A10    | ntsc_ina_clk27  | -                | -            | rcv_clk        | -         | -             | -          |
| C11    | video_inb[0]    | ntsc_inb_data[0] | tcib_data[0] | -              | -         | -             | -          |
| B11    | video_inb[1]    | ntsc_inb_data[1] | tcib_data[1] | -              | -         | -             | -          |
| A11    | video_inb[2]    | ntsc_inb_data[2] | tcib_data[2] | -              | -         | -             | -          |
| D12    | video_inb[3]    | ntsc_inb_data[3] | tcib_data[3] | -              | -         | -             | -          |
| C12    | video_inb[4]    | ntsc_inb_data[4] | tcib_data[4] | -              | -         | -             | -          |
| B12    | video_inb[5]    | ntsc_inb_data[5] | tcib_data[5] | -              | -         | -             | -          |
| A13    | video_inb[6]    | ntsc_inb_data[6] | tcib_data[6] | -              | -         | -             | -          |
| C13    | video_inb[7]    | ntsc_inb_data[7] | tcib_data[7] | -              | -         | -             | -          |
| D13    | video_inb[8]    | ntsc_inb_hsync   | tcib_enable  | -              | dRGB18.R2 | -             | -          |

**Table 4-6 Multiple Signal Pins (Continued)**

| Ball # | Pin Name         | ITU-656 Mode   | TCI Mode   | GPDP Mode       | dRGB Mode                    | ROM Boot Mode              | Reset Mode     |
|--------|------------------|----------------|------------|-----------------|------------------------------|----------------------------|----------------|
| B13    | video_inb[9]     | ntsc_inb_vsync | tcib_err#  | -               | dRGB18.R3                    | -                          | -              |
| J2     | iis_out_data[0]  | -              | -          | -               | -                            | rom_ale                    | -              |
| J3     | iis_out_data[1]  | -              | -          | -               | -                            | rom_wrt#                   | -              |
| H2     | iis_out_data[2]  | -              | -          | -               | -                            | rom_ole#                   | -              |
| F3     | ntsc_out_hsync   | -              | -          | xmt_req         | dRGB18.G2                    | rom_addr[21,19,1]          | -              |
| E1     | ntsc_out_vsync   | -              | -          | rcv_ack         | dRGB18.G3                    | rom_addr[20,18,0]          | -              |
| E2     | ntsc_out_data[0] | -              | -          | xmt_data_out[0] | dRGB24.G0                    | rom_addr[2,10]/rom_data[0] | reset_strap[0] |
| E3     | ntsc_out_data[1] | -              | -          | xmt_data_out[1] | dRGB24.G1                    | rom_addr[3,11]/rom_data[1] | reset_strap[1] |
| C1     | ntsc_out_data[2] | -              | -          | xmt_data_out[2] |                              | rom_addr[4,12]/rom_data[2] | reset_strap[2] |
| C5     | ntsc_out_data[3] | -              | -          | xmt_data_out[3] |                              | rom_addr[5,13]/rom_data[3] | reset_strap[3] |
| B5     | ntsc_out_data[4] | -              | -          | xmt_data_out[4] | dRGB24.R0                    | rom_addr[6,14]/rom_data[4] | reset_strap[4] |
| A4     | ntsc_out_data[5] | -              | -          | xmt_data_out[5] | dRGB24.R1                    | rom_addr[7,15]/rom_data[5] | reset_strap[5] |
| C6     | ntsc_out_data[6] | -              | -          | xmt_data_out[6] | dRGB24.B0                    | rom_addr[8,16]/rom_data[6] | reset_strap[6] |
| D7     | ntsc_out_data[7] | -              | -          | xmt_data_out[7] | dRGB24.B1                    | rom_addr[9,17]/rom_data[7] | reset_strap[7] |
| A9     | tcia_sync        | -              | -          | -               | dRGB12.B7                    | -                          | -              |
| B14    | tcib_sync        | -              | -          | -               | dRGB12.B6                    | -                          | -              |
| A8     | tcia_inuse       | -              | -          | -               | dRGB12.B5                    | -                          | -              |
| A14    | tcib_inuse       | -              | -          | -               | dRGB12.B4                    | -                          | -              |
| B10    | tcia_vdac        | -              | tcia_vdac- | -               | iis_out_data[0] <sup>a</sup> | -                          | -              |
| G3     | iec958_out       | -              | -          | -               | blank                        | -                          | -              |

a. if IIS bypass mode enabled

### 4.8.1 Transport Channel Interfaces (TCI)

The BSP-15 DSP provides two parallel/serial TCI interfaces. See Table 4-7 and Table 4-8.

**Table 4-7 Primary TCI Interface Signals**

| Signal         | # of Pins | I/O | Description   |
|----------------|-----------|-----|---|
| tcia_data[7:0] | (8)       | I   | TCI data input: All 8 bits of input are used in parallel mode. Only tci_data[0] is used in serial mode  |
| tcia_enable    | (1)       | I   | Transport channel enable:<br>1 = accept a TCI input sample<br>0 = ignore TCI input sample   |
| tcia_inuse     | 1         | O   | Video input port external mux select. This pin can also be used as a general purpose output if dynamic muxing of the video input is not required. |

**Table 4-7 Primary TCI Interface Signals**

| Signal     | # of Pins | I/O | Description   |
|------------|-----------|-----|---|
| tcia_sync  | 1         | I   | Demodulator/FEC has marked the synchronization point in the MPEG2 transport stream packet. The packet size is programmable. |
| tcia_err_# | (1)       | I   | This active low signal indicates that the Demodulator/FEC has detected an uncorrectable error in the current packet.        |
| tcia_clk   | 1         | I   | Transport channel clock   |
| TOTAL      | 3(10)     |     |   |

**Table 4-8 Secondary TCI Interface Signals**

| Signal         | # of Pins | I/O | Description   |
|----------------|-----------|-----|---|
| tcib_data[7:0] | (8)       | I   | TCI data input: All 8-bits of input are used in parallel mode. Only tci_data[0] is used in serial mode.   |
| tcib_enable    | (1)       | I   | Transport channel enable:<br>1 = accept a TCI input sample<br>0 = ignore TCI input sample   |
| tcib_inuse     | 1         | O   | Video input port external mux select. This pin can also be used as a general purpose output if dynamic muxing of the video input is not required. |
| tcib_sync      | 1         | I   | Demodulator/FEC has marked the synchronization point in the MPEG2 transport stream packet. The packet size is programmable.                       |
| tcib_err#      | (1)       | I   | This active low signal indicates that the Demodulator/FEC has detected an uncorrectable error in the current packet.                              |
| tcib_clk       | 1         | I   | Transport channel clock   |
| TOTAL          | 3(10)     |     |   |

## 4.8.2 ITU-656 Inputs

Analog video can be digitized according to ITU-R BT.601/656 via a NTSC, PAL or SVIDEO decoder and then input to the BSP-15 DSP. The interface signals for the primary and secondary video inputs are shown in Table 4-9 and Table 4-10.

**Table 4-9 Primary ITU-R BT.601/656 Input Interface Signals**

| Signal             | # of Pins | I/O | Description                                   |
|--------------------|-----------|-----|---|
| ntsc_ina_clk27     | 1         | I   | 27 MHz clock from video decoder               |
| ntsc_ina_hsync     | (1)       | I   | Horizontal sync                               |
| ntsc_ina_vsync     | (1)       | I   | Vertical sync                                 |
| ntsc_ina_data[7:0] | (8)       | I   | ITU-R BT.601/656 formatted video input stream |
| TOTAL              | 1(10)     |     |   |

**Table 4-10 Secondary ITU-R BT.601/656 Input Interface Signals**

| Signal             | # of Pins | I/O | Description                                   |
|--------------------|-----------|-----|---|
| ntsc_inb_clk27     | 1         | I   | 27 MHz clock from video decoder               |
| ntsc_inb_hsync     | (1)       | I   | Horizontal sync                               |
| ntsc_inb_vsync     | (1)       | I   | Vertical sync                                 |
| ntsc_inb_data[7:0] | (8)       | I   | ITU-R BT.601/656 formatted video input stream |
| TOTAL              | 1(10)     |     |   |

### 4.8.3 ITU-656 Output

The BSP-15 DSP has a digital ITU-R BT.601/656 output interface as shown in Table 4-11.

**Table 4-11 ITU-R BT.601/656 Output Interface Signals**

| Signal             | # of Pins | I/O | Description   |
|--------------------|-----------|-----|---|
| pclk               | (1)       | I   | 27 MHz pixel clock from VCXO clock input. See Section 4.3.  |
| ntsc_out_hsync     | 1         | O   | Horizontal sync   |
| ntsc_out_vsync     | 1         | O   | Vertical sync   |
| ntsc_out_data[7:0] | 8         | B   | ITU-R BT.601/656 formatted NTSC/PAL output data configured as input only when used for ROM interface or reset strap |
| TOTAL              | 10(1)     |     |   |

### 4.8.4 General Purpose Data Port (GPDP)

The primary video input port and the video output port can be coupled together to function as a general purpose 8-bit duplex data port.

**Table 4-12 GPDP Interface Signals**

| Signal            | # of Pins | I/O | Description  |
|-------------------|-----------|-----|--|
| xmt_clk           | (1)       | I   | transmitter output clock, shared with pixelclk_byp_in                    |
| xmt_req           | (1)       | O   | GPDP on BSP-15 DSP is ready to transmit data. Shared with ntsc_out_hsync |
| xmt_ack           | (1)       | I   | output source is ready to accept data, shared with video_ina[9]          |
| xmt_data_out[7:0] | (8)       | O   | Parallel data output on ntsc_out_data[7:0]                               |
| rcv_clk           | (1)       | I   | Receiver input clock shared with ntsc_ina_clk27                          |
| rcv_req           | (1)       | I   | Input source is ready to send data. Shared with video_ina[8]             |
| rcv_ack           | (1)       | O   | GPDP on BSP-15 DSP is ready to accept data, shared with ntsc_out_vsync   |

**Table 4-12 GPDP Interface Signals**

| Signal           | # of Pins | I/O | Description                           |
|------------------|-----------|-----|---------------------------------------|
| rcv_data_in[7:0] | (8)       | I   | Parallel data input on video_ina[7:0] |
| TOTAL            | (22)      |     |                                       |

### 4.8.5 Flash ROM

A Flash ROM (EEPROM) interface is provided on the BSP-15 DSP to assist in boot-up. The Flash ROM is active during the boot up process and must be disabled through its chip-select signal. See Section 3.3.2, *MAP Hardware Reference Manual, Volume 4* for information about programming the timing parameters of the ROM interface.

**Table 4-13 ROM Interface Signals**

| Signal  | # of Pins | I/O | Description  |
|---|-----------|-----|--|
| rom_cs#   | 1         | O   | This pin is the chip enable signal.  |
| rom_oe#   | (1)       | O   | This active low signal is asserted on ROM read cycles. This signal is multiplexed with iis_out_data[2].  |
| rom_wrt#  | (1)       | O   | This active low signal is asserted on ROM write cycles. This signal is multiplexed with iis_out_data[1].   |
| rom_ale   | (1)       | O   | Address latch enable:<br>rom_addr[9:2] and rom_addr[19:18] are latched on the falling edge,<br>rom_addr[17:10] and rom_addr[21:20] are latched on the rising edge;<br>this signal is multiplexed with iis_out_data[0]. |
| rom_addr[19:18]/<br>rom_addr[21:20]/<br>rom_addr[1:0] | (2)       | O   | rom_addr[19]/rom_addr[21]/rom_addr[1] is muxed with ntsc_out_hsync.<br>rom_addr[18]/rom_addr[20]/rom_addr[0] is muxed with ntsc_out_vsync.   |
| rom_addr[9:2]/<br>rom_addr[17:10]/<br>rom_data[7:0]   | (8)       | B   | ROM data and address bus. These signals are multiplexed with ntsc_out_data[7:0].   |
| TOTAL   | 1(13)     |     |  |

### 4.8.6 Reset Straps

The board resistor straps are sampled on the de-assertion (rising edge) of pci\_rst\_.

**Table 4-14 Reset Straps**

| Signal                              | # of Pins | I/O | Description  |
|-------------------------------------|-----------|-----|--|
| reset_strap[7:4]<br>(sw_strap[3:0]) | (4)       | I   | Resistor straps for use by software. These signals are multiplexed with rom_data[7:4] and ntsc_out_data[7:4].  |
| reset_strap[1]<br>(pci_host)        | (1)       | I   | VDD = 1 = BSP-15 DSP is hosting the primary PCI bus<br>GND = 0 = BSP-15 DSP is not hosting<br>The signal is multiplexed with rom_data[1] and ntsc_out_data[1]. |

**Table 4-14 Reset Straps**

| Signal                       | # of Pins | I/O | Description  |
|------------------------------|-----------|-----|--|
| reset_strap[0]<br>(rom_boot) | (1)       | I   | VDD = 1 = Flash ROM is used for boot<br>GND = 0 = ROMless boot<br>The signal is multiplexed with rom_data[0] and ntsc_out_data[0]. |
| TOTAL                        | (6)       |     |  |

## 4.9 Analog CRT

An RGB monitor can be directly driven by the BSP-15 DSP.

**Table 4-15 CRT Interface Signals**

| Signal      | # of Pins | I/O | Description                               |
|-------------|-----------|-----|---|
| vsync       | 1         | O   | Vertical synchronization signal for CRT   |
| hsync       | 1         | O   | Horizontal synchronization signal for CRT |
| gdac_fscale | 1         | A   | Full scale current adjusting resistor     |
| gdac_comp   | 1         | A   | Vref bypass and compensation capacitor    |
| gdac_blue   | 1         | A   | Analog blue output                        |
| gdac_green  | 1         | A   | Analog green output                       |
| gdac_red    | 1         | A   | Analog red output                         |
| TOTAL       | 7         |     |   |

## 4.10 Digital RGB

The BSP-15 processor provides a digital RGB interface that connects gluelessly to an active matrix flat panel display using a pixel depth of 12, 18, or 24 bits.

Table 4-16: Digital RGB interface signals

| Signal             | # of Pins | I/O | Description                               |
|--------------------|-----------|-----|---|
| vsync              | 1         | O   | Vertical synchronization signal for CRT   |
| hsync              | 1         | O   | Horizontal synchronization signal for CRT |
| pixelclk_out       | 1         | O   | Pixel clock                               |
| iec958_out         | 1         | O   | Blank                                     |
| video_ina[7:4]     | 4         | O   | red[7:4]                                  |
| video_inb[9:8]     | 2         | O   | red[3:2]                                  |
| ntsc_out_data[5:4] | 2         | O   | red[1:0]                                  |
| video_ina[3:0]     | 4         | O   | green[7:4]                                |

Table 4-16: Digital RGB interface signals

| Signal             | # of Pins | I/O | Description |
|--------------------|-----------|-----|-------------|
| ntsc_out_vsync     | 1         | O   | green[3]    |
| ntsc_out_hsync     | 1         | O   | green[2]    |
| ntsc_out_data[1:0] | 2         | O   | green[1:0]  |
| tcia_sync          | 1         | O   | blue[7]     |
| tcib_sync          | 1         | O   | blue[6]     |
| tcia_inuse         | 1         | O   | blue[5]     |
| tcib_inuse         | 1         | O   | blue[4]     |
| video_ina[7:6]     | 2         | O   | blue[3:2]   |
| ntsc_out_data[5:4] | 2         | O   | red[1:0]    |
| TOTAL              | 28        |     |             |

## 4.11 IIC

The BSP-15 DSP provides an IIC interface to communicate with external peripherals such as NTSC decoders, NTSC encoders, and demodulators. The pin description is shown in 4-17.

Table 4-17 IIC Interface Signals

| Signal     | # of Pins | I/O    | Description  |
|------------|-----------|--------|--|
| iic_sda    | 1         | B (od) | IIC data line  |
| iic_sck    | 1         | B (od) | IIC clock line   |
| iic_select | 1         | O      | IIC-bus external mux select. This pin can also be used as general purpose output |
| TOTAL      | 3         |        |  |

## 4.12 Boundary Scan (JTAG)

BSP-15 DSP supports boundary scan interface based on *IEEE 1149.1 Standard Test Access Port and Boundary-Scan Architecture* for testing the BSP-15 DSP and other devices on the board. A BSDL (Boundary Scan Description Language) file is available from Equator.

Table 4-18 JTAG Interface Signals

| Signal          | # of Pins | I/O | Description  |
|-----------------|-----------|-----|--|
| t <sub>ck</sub> | 1         | I   | Reference clock. This specifies the timing for all the transactions of JTAG interface. |
| t <sub>ms</sub> | 1         | I   | Test interface mode select signal.   |
| t <sub>di</sub> | 1         | I   | Test interface data input  |
| t <sub>do</sub> | 1         | O   | Test interface data output   |



**Table 4-18 JTAG Interface Signals**

| Signal    | # of Pins | I/O | Description   |
|-----------|-----------|-----|---|
| $t_{rst}$ | 1         | I   | Active-low reset for the circuitry. It must be low at power up. |
| TOTAL     | 5         |     |   |

## 4.13 Power/Ground Pins

The following power and ground pins are provided on BSP-15 DSP.

**Table 4-19 Power/Ground Pins**

| Name                   | # of Pins | Description                                  |
|------------------------|-----------|--|
| Vddcore                | 30        | Digital Core Vdd                             |
| VddI/O                 | 27        | I/O Power Supply 3.3V                        |
| Vss                    | 57        | Digital Vss                                  |
| aVdd_PLL1 (B3, D5)     | 2         | Clean analog Vdd for PLL                     |
| aVdd_PLL2 (AE24, AF25) | 2         | Clean analog Vdd for PLL                     |
| aVdd_DAC (D16)         | 1         | Clean analog Vdd for Video DAC               |
| aVddx (D17)            | 1         | Clean analog Vdd for Video DAC               |
| aVss (A17)             | 1         | Clean analog Vss for aVdd_DAC ground return  |
| aVss (A3, C4)          | 2         | Clean analog Vss for aVdd_PLL1 ground return |
| aVss (AC22, AD23)      | 2         | Clean analog Vss for aVdd_PLL2 ground return |
| aVssx (B19)            | 1         | Clean analog Vss for aVddx ground return     |
| gdac_cvgg (C18)        | 1         | Clean analog Vss for Video DAC               |
| TOTAL                  | 127       |  |

## 4.14 Signal List Summary

**Table 4-20 BSP-15 DSP Pin List**

| Interface    | Frequency                  | Pin Count | Remarks                                  |
|--------------|----------------------------|-----------|--|
| Clocks       | Various                    | 9         | reference clocks including bypass clocks |
| PCI          | 66/33 MHz                  | 54        | host/system interface                    |
| SDRAM        | 133 MHz                    | 97        | memory interfaces (SDRAM, EEPROM)        |
| Flash ROM    | 5 MHz                      | 1(13)     |  |
| Reset Straps | -                          | (6)       | configuration inputs                     |
| IEC958       | 32/44.1/48 kHz sample rate | 2         | digital audio I/O                        |

**Table 4-20 BSP-15 DSP Pin List**

| Interface            | Frequency  | Pin Count | Remarks  |
|----------------------|--|-----------|--|
| IIS                  | 32/44.1/48 kHz sample rate<br>1.536/2.116 MHz bit rate | 8         | digital audio I/O  |
| ITU-R BT.601/656 In  | 27 MHz   |           | two video input streams:<br>2 TCI or<br>2 ITU-656, or<br>1 TCI and 1 ITU-656, or<br>GPDP and 1 video input (TCI or<br>ITU-656) |
| Parallel/Serial TCI  | 30/80 MHz  |           |  |
| GPDP                 | 60 MHz   |           |  |
| ITU-R BT.601/656 Out | 27 MHz   | 10(1)     | digital video out or GPDP  |
| CRT Out              | 25-110 MHz   | 7         | analog video out   |
| IIC                  | 100/400 kHz  | 3         | peripheral control   |
| Test                 | 25 MHz   | 5         | boundary scan (JTAG)   |
| Signal Pins Total    | -  | 224       |  |
| Power/Ground         | -  | 127       |  |
| Miscellaneous        | -  | 0         | reserved (tie to ground)   |
|                      | -  | 1         | no connection (leave floating)   |
| TOTAL                |  | 352       |  |

# Chapter 5 External Connection Examples

## 5.1 SDRAM

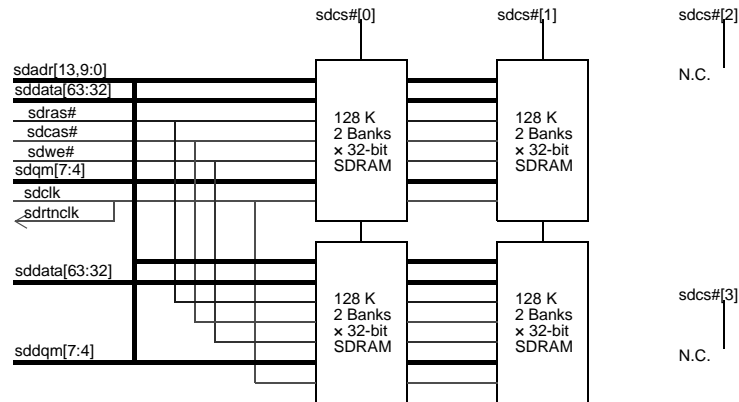

Figure 5.1 64-bit, 4 MB configuration using  $\times 32$ , 8 Mb parts

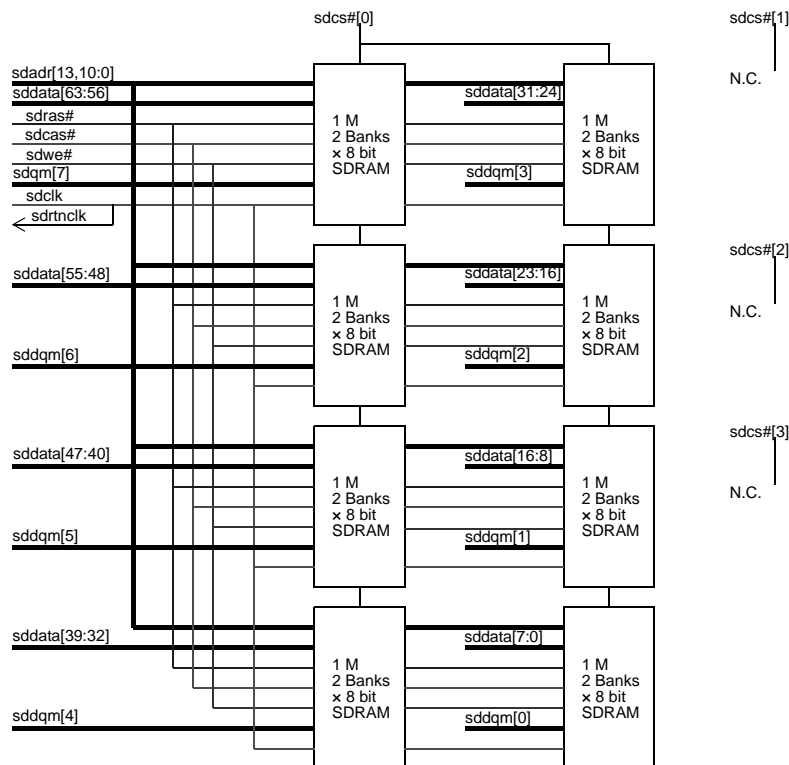
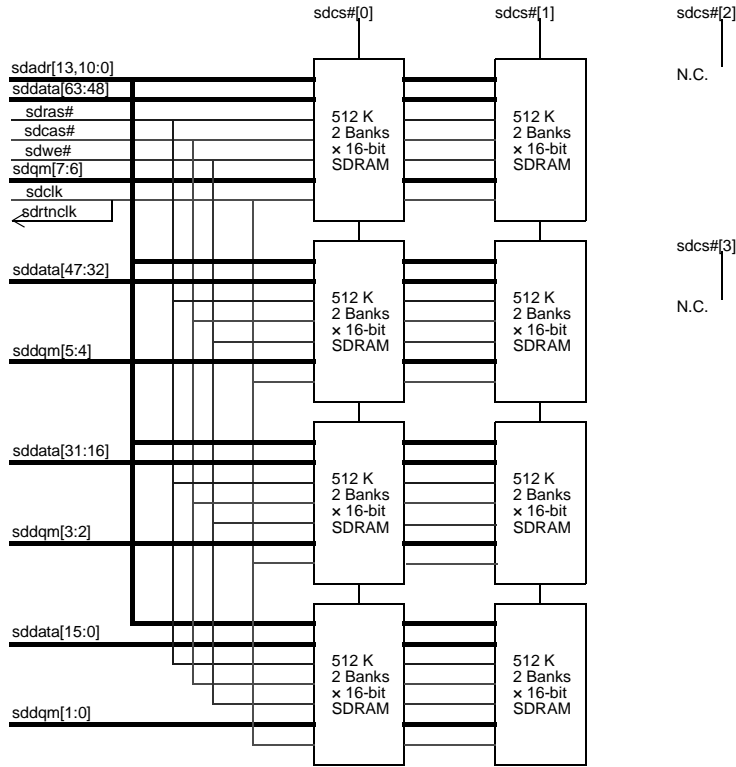
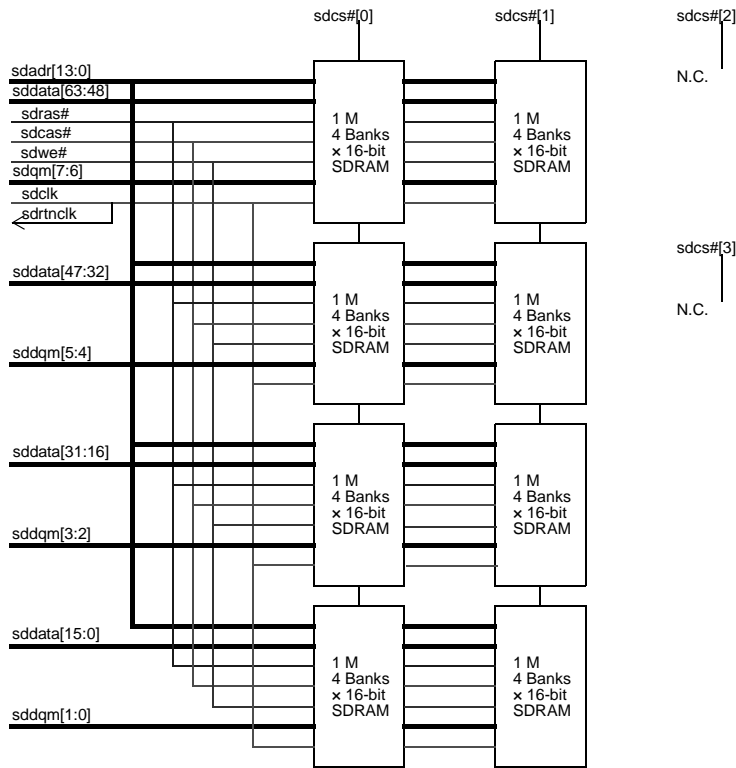

Figure 5.2 64-bit, 16 MB configuration using  $\times 8$ , 16 Mb parts



**Figure 5.3 64-bit, 16 MB configuration using ×16 16 Mb parts**



**Figure 5.4 64-bit, 64 MB configuration using ×16, 64 Mb parts**

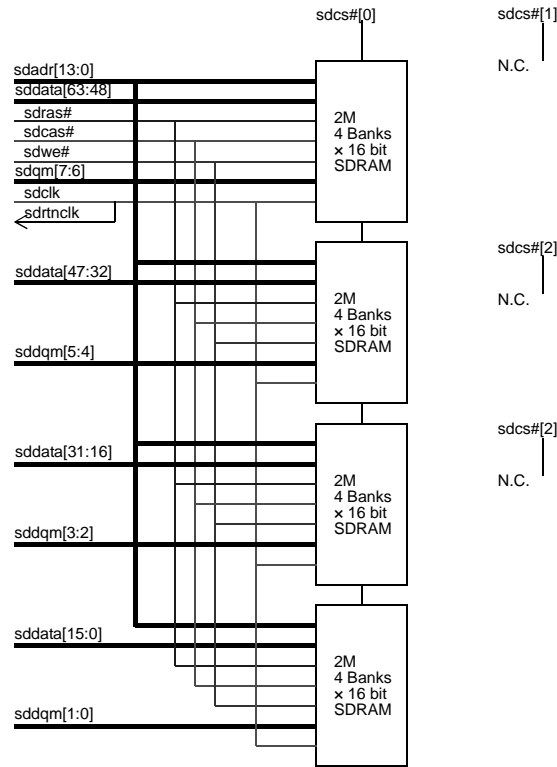

**Figure 5.5 64-bit, 64 MB configuration using  $\times 16$ , 128 Mb**

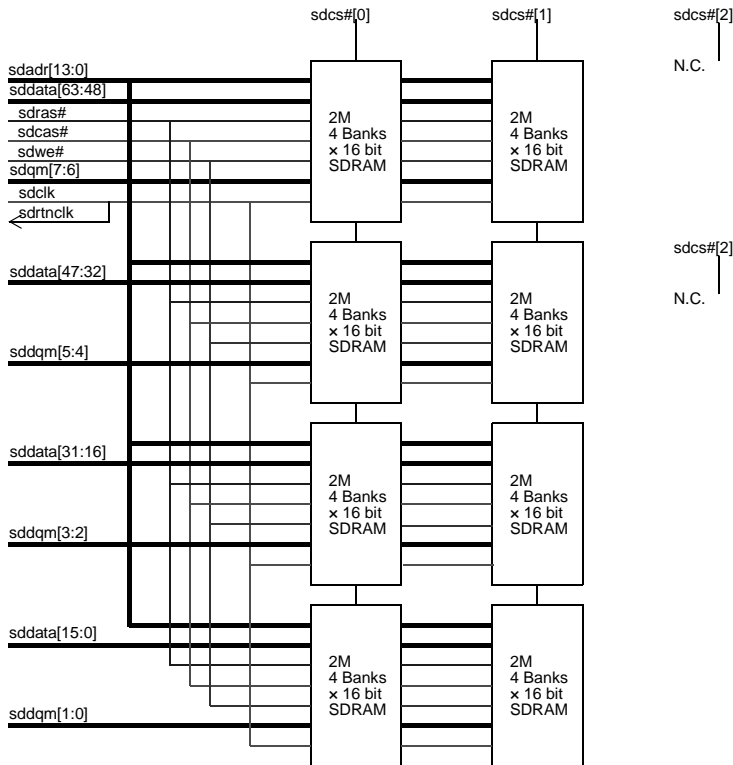

**Figure 5.6 64-bit, 128 MB configuration using  $\times 16$ , 128 Mb**

## 5.2 IEC958

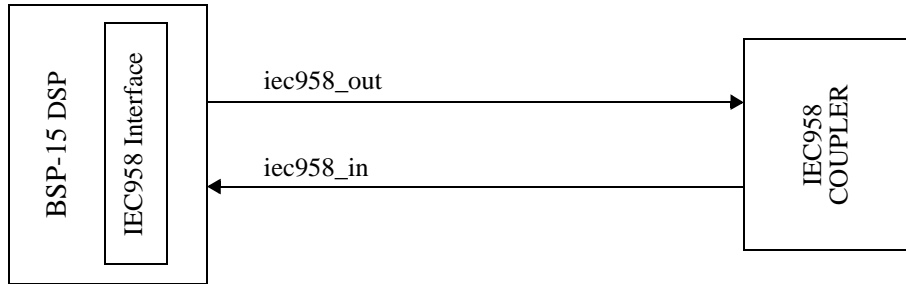

Figure 5.7 IEC958 interface

## 5.3 IIS

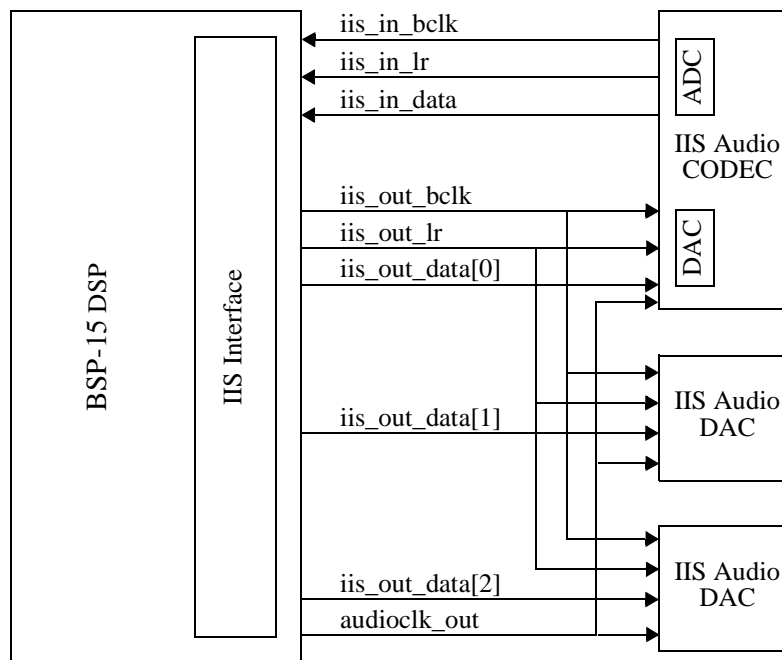

Figure 5.8 IIS interface



Reference designs may use `iis_out_bclk` and `iis_out_lr` as input clocks. See the reference board documentation.

## 5.4 Transport Channel Interface (TCI)

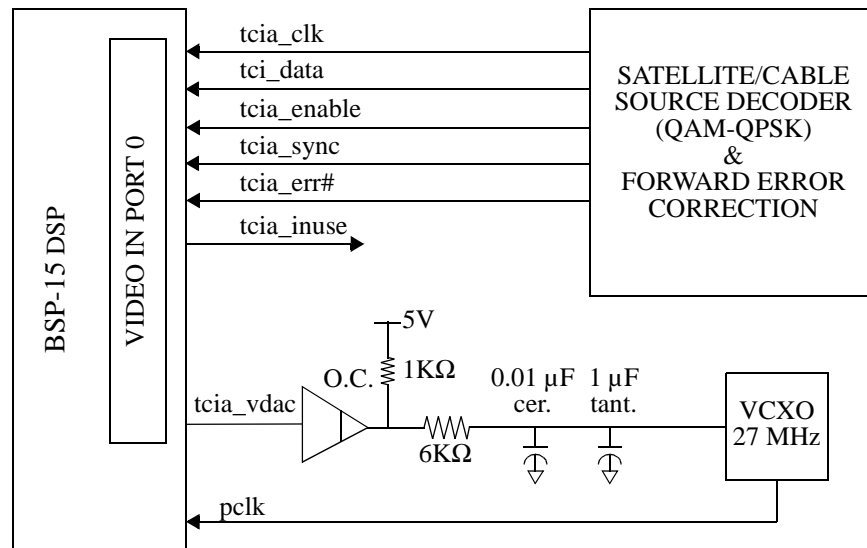

Figure 5.9 Transport Channel

## 5.5 NTSC Decoder

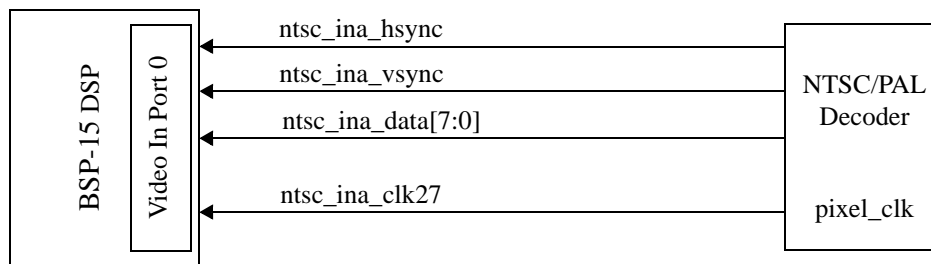

Figure 5.10 ITU-R BT.656 NTSC/PAL decoder

## 5.6 NTSC Encoder

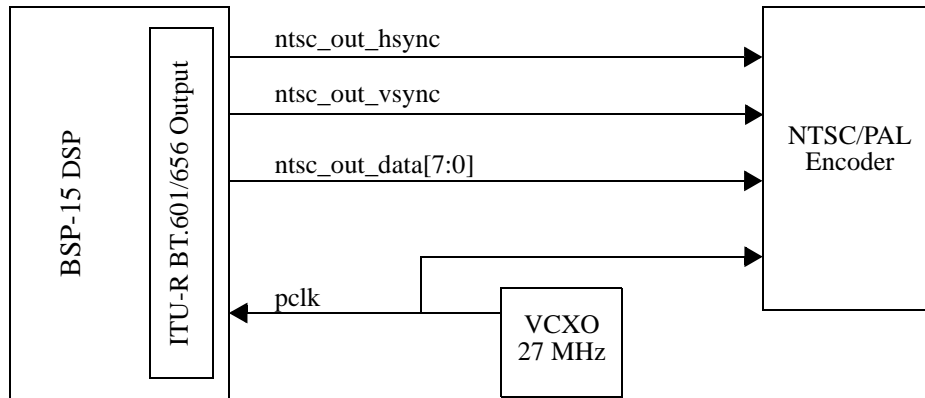

Figure 5.11 NTSC/PAL encoder

## 5.7 CRT

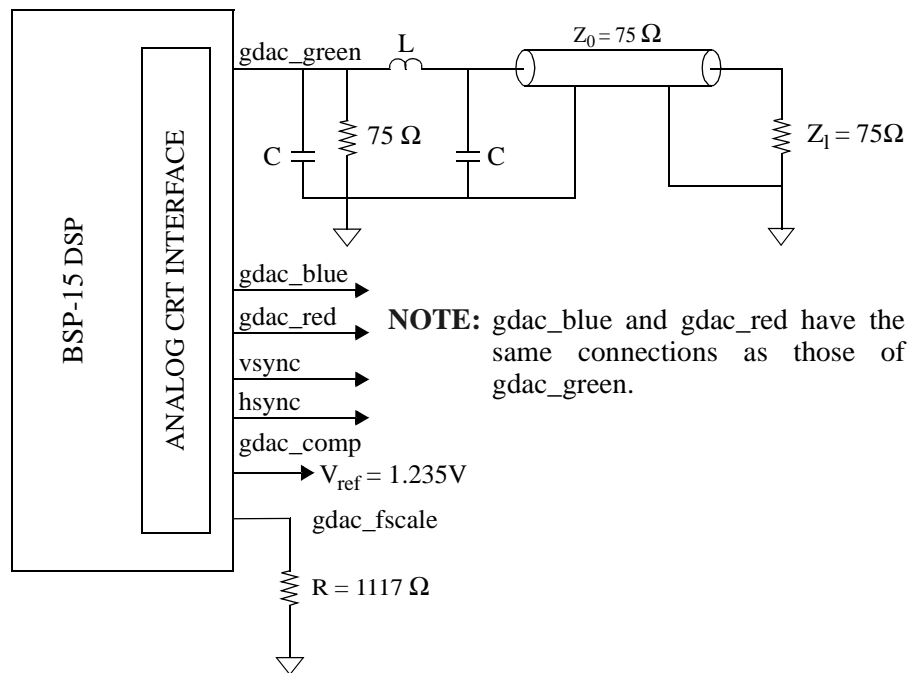

Figure 5.12 CRT



## 5.8 IIC

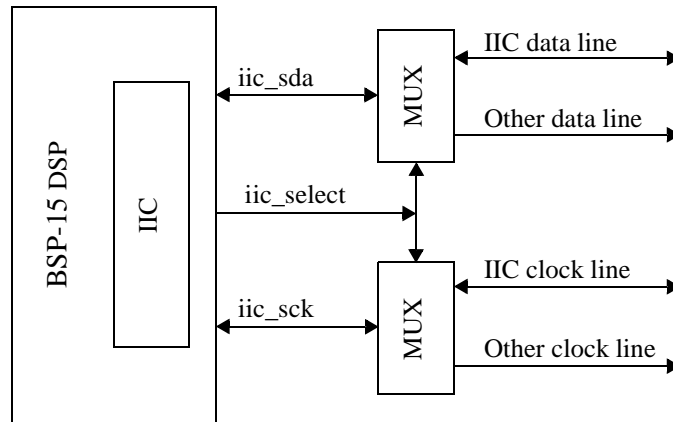

Figure 5.13 IIC interface

## 5.9 ROM

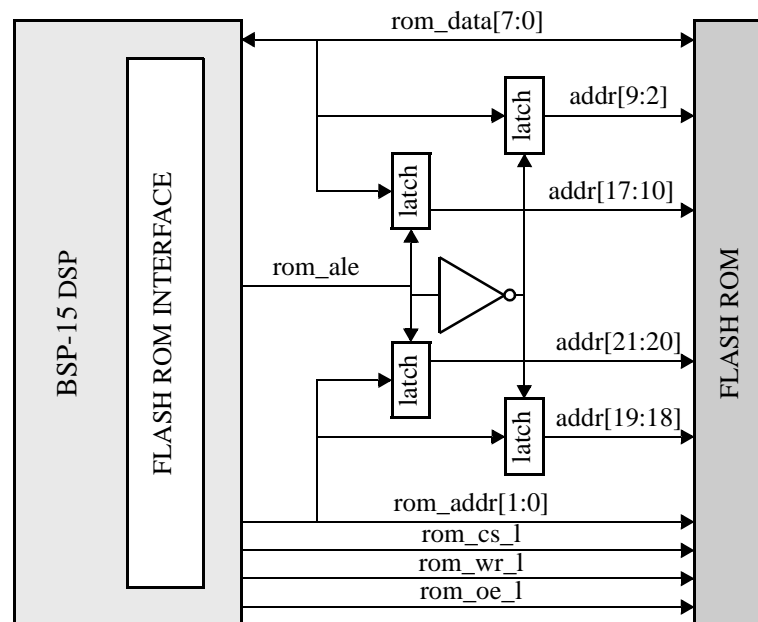

Figure 5.14 ROM connections



---

# Chapter 6                      Electrical Specifications

---

Note: All electrical specifications are preliminary.

## 6.1 Absolute Maximum Ratings

Exceeding the maximum values listed in Table 6-1 may cause permanent damage to the BSP-15 digital signal processor. This is a stress rating only, and functional operation of the device at these or any other conditions above those listed in the operational sections of this specification is not implied. Exposure to absolute maximum rating conditions for extended periods may affect device reliability.

**Table 6-1 Absolute Maximum Ratings**

| Parameter   | Max          | Unit |
|---|--------------|------|
| Vddcore (measured to Vss)                                       | 1.485        | V    |
| VddI/O, aVdd_PLL1, aVdd_PLL2, aVddx, aVdd_DAC (measured to Vss) | 3.60         | V    |
| Voltage on any signal pin <sup>a, b</sup>                       | VddI/O + 0.5 | V    |
| Storage Temperature   | 150          | °C   |
| Junction Temperature  | 110          | °C   |
| Solder Reflow Temperature                                       | 225          | °C   |

- a. This device employs CMOS devices on all signal pins. It should be handled as an ESD sensitive device. Voltage on any signal pin that exceeds the power supply voltage by more than +0.5 V can induce destructive latchup.
- b. PCI Bus pins are 5 V tolerant.

## 6.2 Power Supply Specifications

**Table 6-2 Voltage Variation**

| Power Supply <sup>a</sup> | Voltage    |            |            |
|---------------------------|------------|------------|------------|
|                           | BSP-15-300 | BSP-15-350 | BSP-15-400 |
| Vddcore                   | 1.20V ±5%  | 1.27V ±5%  | 1.35V ±5%  |
| VddI/O                    | 3.3V ±5%   |            |            |
| aVdd_PLL1                 | 3.3V ±5%   |            |            |
| aVdd_PLL2                 | 3.3V ±5%   |            |            |
| aVdd_DAC                  | 3.3V ±5%   |            |            |
| aVddx                     | 3.3V ±5%   |            |            |

a. Tolerance includes both static and transient variation

The typical estimated total power consumption is 2.5-4.8 W depending on speed, applications, and I/O loading.



During power-up, Vddcore must come up before or simultaneously with VddI/O. VddI/O should not exceed Vddcore by more than 0.4 V while Vddcore is less than 1V. There is no restriction on the power-down sequence.

The BSP-15 DSP's PLL supply and both DAC's use 3.3 V.

**Table 6-3 Steady State Current**

| Power Supply              | Estimated Max Steady State Current |                               |                               |
|---------------------------|------------------------------------|-------------------------------|-------------------------------|
|                           | BSP-15-300<br>(Vddcore 1.2V)       | BSP-15-350<br>(Vddcore 1.27V) | BSP-15-400<br>(Vddcore 1.35V) |
| Vddcore                   | 1.6 A                              | 2.2 A                         | 2.9 A                         |
| VddI/O                    | 0.25 A                             | 0.25 A                        | 0.25 A                        |
| aVdd_PLL1 or<br>aVdd_PLL2 | 50 mA<br>(all 3 PLLs running)      | 50 mA                         | 50 mA                         |
| aVdd_DAC                  | 80 mA                              | 80 mA                         | 80 mA                         |
| aVddx                     | 5 mA                               | 5 mA                          | 5 mA                          |

## 6.3 BSP-15 DC Characteristics

**Table 6-4 Input/Output Signals**

| Parameter         | Description                      | Condition                                | Min  | Max                      | Unit |
|-------------------|----------------------------------|--|------|--------------------------|------|
| V <sub>IL</sub>   | Input low voltage                | -  | -0.5 | 0.6                      | V    |
| V <sub>IH</sub>   | Input high voltage               | -  | 2.0  | V <sub>ddI/O</sub> + 0.5 | V    |
| V <sub>OL</sub>   | Output low voltage               | I <sub>out</sub> = 2 mA                  | -    | 0.4                      | V    |
| V <sub>OH</sub>   | Output high voltage              | I <sub>out</sub> = 2 mA                  | 2.4  | -                        | V    |
| I <sub>LI</sub>   | Input leakage current            | 0 < V <sub>in</sub> < V <sub>ddI/O</sub> | -10  | 10                       | μA   |
| I <sub>LIPU</sub> | Leakage current of pull up pin   | 0 < V <sub>in</sub> < V <sub>ddI/O</sub> | -300 | 10                       | μA   |
| I <sub>LIPD</sub> | Leakage current of pull down pin | 0 < V <sub>in</sub> < V <sub>ddI/O</sub> | -10  | 300                      | μA   |
| I <sub>OZ</sub>   | Tri-state output leakage         | 0 < V <sub>in</sub> < V <sub>ddI/O</sub> | -10  | 10                       | μA   |
| C <sub>IN</sub>   | Input pin capacitance            | -  | -    | 10                       | pF   |
| C <sub>IO</sub>   | Input/output pin capacitance     | -  | -    | 12                       | pF   |

→ The relationship between `gdac_fscale_f` and the full scale output current on IOG is:

$$\text{IOG (mA)} = 24.12 \times \text{gdac\_comp(V)} / \text{gdac\_fscale\_f(ohm)}$$

where `gdac_comp` is 1.235 V (typical).

**Table 6-5 Video DAC outputs - aRGB mode**

| Parameter                     | Symbol | Min   | Typical    | Max   | Unit |
|-------------------------------|--------|-------|------------|-------|------|
| Resolutions (FS)              | -      | 8     | 8          | 8     | Bits |
| Integral nonlinearity         | INL    | -     | -          | ± 2   | LSB  |
| Differential nonlinearity     | DNL    | -     | -          | ± 1   | LSB  |
| Monotonicity                  | -      | -     | guaranteed | -     | -    |
| White level relative to blank | -      | 17.69 | 19.05      | 20.40 | mA   |
| White level relative to black | -      | 16.74 | 17.62      | 18.50 | mA   |
| Black level relative to blank | -      | 0.95  | 1.44       | 1.90  | mA   |
| Blank level on IOG            | -      | 6.29  | 7.62       | 8.96  | mA   |
| Blank level on IOR, IOB       | -      | 0     | 5          | 50    | μA   |
| Sync level on IOG             | -      | 0     | 5          | 50    | μA   |
| LSB size                      | -      | -     | 69.1       | -     | μA   |
| DAC-to-DAC matching           | -      | -     | 2          | 5     | %    |
| Output resistance             | RAOUT  | -     | 37.5       | -     | Ω    |

## 6.4 AC Characteristics

The AC timing specifications listed in this section assume a 20 pF load on all output signals of the BSP-15 DSP.

### 6.4.1 PLL reference clock input

**Table 6-6 PLL Reference Clock Input Conditions**

| Description                   | Value                       |
|-------------------------------|-----------------------------|
| Rise/fall time                | 2 ns maximum (0.4V to 2.4V) |
| Duty cycle                    | 50% $\pm$ 10%               |
| Maximum cycle to cycle jitter | $\pm$ 200 ps                |

### 6.4.2 SDRAM interface timing

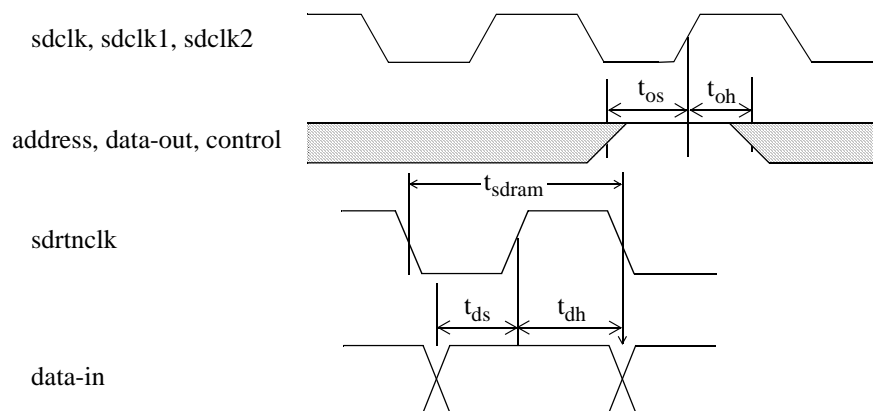

**Figure 6.1 SDRAM timing measurement conditions**

Correct setup and hold times can be guaranteed through internal delay adjustment, controlled by bits [30:24] of the synchronizer/clock control register in the BSP-15 DSP's memory block. The SdMrckDly and SdMckDly fields control internal delay circuits that affect the timing of signals going to and from

the SDRAM components. They should be adjusted so that setup and hold requirements of both the SDRAM and the BSP-15 DSP are met.

**Table 6-7 SDRAM interface timing parameters<sup>a</sup>**

| Symbol                        | Description  | Min | Max | Unit |
|-------------------------------|--|-----|-----|------|
| $f_{\text{sdrām}}^{\text{b}}$ | sdclk frequency  | -   | 135 | MHz  |
| $t_{\text{os}}$               | Output setup time for address, data, control (sdcs#, sdras#, sdcas#, sdwe#, sddqm) | 1.5 | -   | ns   |
| $t_{\text{oh}}^{\text{c}}$    | Output hold time of address, data, control (sdcs_, sdras_, sdcas_, sdwe_, sddqm)   | 1.5 | -   | ns   |
| $t_{\text{ds}}^{\text{d, e}}$ | Input data setup time  | 2   | -   | ns   |
| $t_{\text{dh}}^{\text{c, d}}$ | Input data hold time   | 2   | -   | ns   |

- Measured with SdMrckDly = 0 and SdMckDly = 3.
- $f_{\text{sdrām}} = 1 / t_{\text{sdrām}}$
- The center of the rising edges of sdclk1 and sdclk2 is used as the reference point.
- sdrtnclk is used as the reference clock.
- A matching mechanism is provided to compensate for the propagation delay through circuit board traces to and from the external SDRAM devices. To optimize read timing margin, sdrtnclk should be connected to sdclk with a dedicated trace, with an optional lumped RC load attached to the middle, to account for the number of SDRAM devices attached to the clock line.

### 6.4.3 PCI bus timing

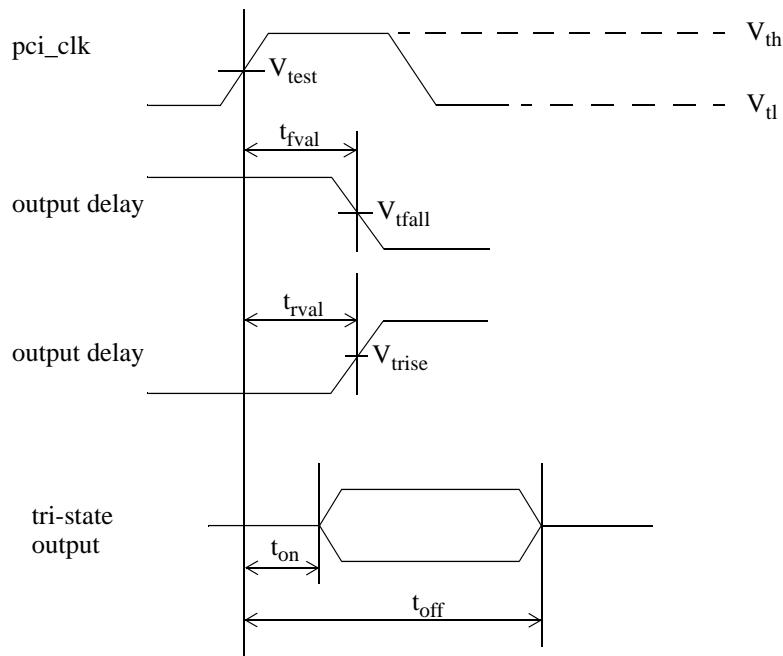

**Figure 6.2 PCI output timing measurement conditions**

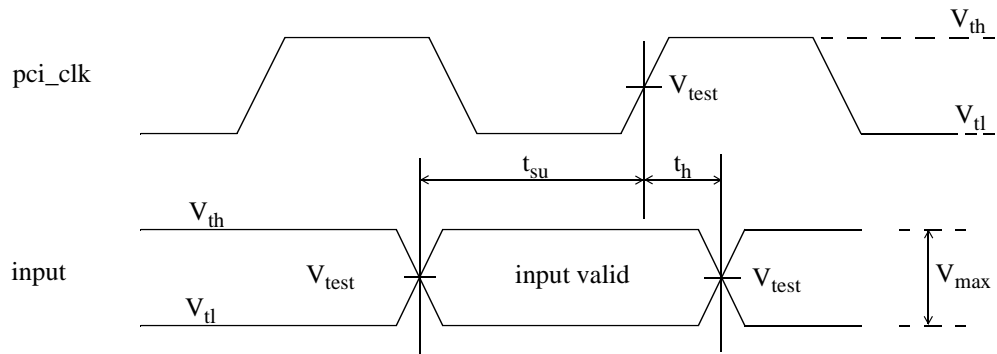

**Figure 6.3 PCI input timing measurement conditions**



**Table 6-8 PCI interface timing parameters**

| Symbol                      | Description                                      | Min | Max | Unit          |
|-----------------------------|--|-----|-----|---------------|
| $t_{\text{pci\_clk}}$       | clock cycle time                                 | 15  | 30  | ns            |
| $t_{\text{high}}$           | clock high time                                  | 6   | -   | ns            |
| $t_{\text{low}}$            | clock low time                                   | 6   | -   | ns            |
| $\text{clk}_{\text{slew}}$  | clock slew rate                                  | 1.5 | 4   | V/ns          |
| $t_{\text{su(bus)}}$        | input set up time to clk, bussed signals         | 3   | -   | ns            |
| $t_{\text{su(ptp)}}$        | input set up time to clk, point-to-point signals | 5   | -   | ns            |
| $t_{\text{val(bus)}}$       | clk to signal valid delay, bussed signals        | 2   | 6   | ns            |
| $t_{\text{val(ptp)}}$       | clk to signal valid delay, point to point signal | 2   | 6   | ns            |
| $t_{\text{on}}$             | float to active delay                            | 2   | -   | ns            |
| $t_{\text{off}}$            | active to float delay                            | -   | 14  | ns            |
| $t_{\text{h}}$              | input hold time from clock                       | 500 | -   | ps            |
| $t_{\text{rst}}^{\text{a}}$ | reset active time after power stable             | 1   | -   | ms            |
| $t_{\text{rst-clk}}$        | reset active time after clk stable               | 100 | -   | $\mu\text{s}$ |
| $t_{\text{rst-off}}$        | reset active to output float delay               | -   | 40  | ns            |

- a.  $\text{pci\_rst}_-$  is asserted and de-asserted asynchronously with respect to  $\text{pci\_clk}$ . All output drivers are floated when  $\text{pci\_rst}_-$  is active.

**Table 6-9 PCI measurement conditions**

| Symbol                 | Value                    | Unit |
|------------------------|--------------------------|------|
| $V_{\text{max}}$       | 0.4 V <sub>ddI/O</sub>   | V    |
| $V_{\text{test}}$      | 0.4 V <sub>ddI/O</sub>   | V    |
| $V_{\text{tfall}}$     | 0.615 V <sub>ddI/O</sub> | V    |
| $V_{\text{th}}$        | 0.6 V <sub>ddI/O</sub>   | V    |
| $V_{\text{tl}}$        | 0.2 V <sub>ddI/O</sub>   | V    |
| $V_{\text{trise}}$     | 0.285 V <sub>ddI/O</sub> | V    |
| Input signal slew rate | 1.5                      | V/ns |

## 6.4.4 IEC958 interface timing

**Table 6-10 IEC958 interface timing parameters**

| Symbol | Description       | Min | Typical | Max | Unit |
|--------|-------------------|-----|---------|-----|------|
| $F_s$  | Audio sample rate | 32  | 44.1    | 48  | kHz  |

## 6.4.5 IIS interface timing

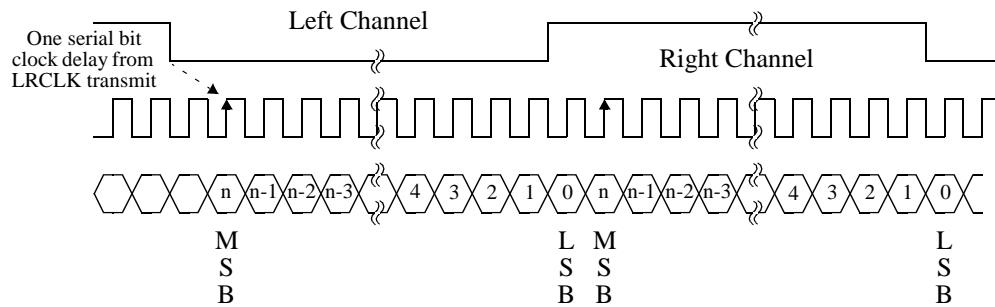

**Figure 6.4 IIS data format**

The audio PLL generates `audioclk_out` for use by external codecs as master MCLK. MCLK can be programmed for either 12.288 MHz or 16.933 MHz to achieve the desired audio sample rate (LRCLK), according to Table 6-11. The MSB:LSB ordering can be reversed by software programming.

**Table 6-11 IIS clock ratios**

| LRCLK <sup>a</sup><br>(kHz) | MCLK <sup>b</sup><br>(MHz) | SCLK <sup>c</sup><br>(MHz) | MCLK/<br>LRCLK | MCLK/<br>SCLK | BITS/<br>FRAME <sup>d</sup> | BITS/<br>CHANNEL |
|-----------------------------|----------------------------|----------------------------|----------------|---------------|-----------------------------|------------------|
| 48(TDB)                     | 12.288                     | 1.536                      | 256            | 8             | 32                          | 16               |
| 44.1                        | 16.933 <sup>e</sup>        | 2.116                      | 384            | 8             | 48                          | 24               |
| 32                          | 12.288                     | 1.536                      | 384            | 8             | 48                          | 24               |

- LRCLK = iis\_in\_lr or iis\_out\_lr.
- MCLK = audioclk\_out; MCLK defaults to 27 MHz on power-up (audio PLL bypassed).
- SCLK = iis\_in\_bclk or iis\_out\_bclk.
- Bits/Frame = 2\*Bits/Channel = SCLK/LRCLK. When MCLK/LRCLK = 384, 24 bits per channel are always transmitted, but the number of valid bits is selectable from 16, 18, 20 or 24.
- MCLK defaults to 16.933 MHz when audio PLL is enabled.

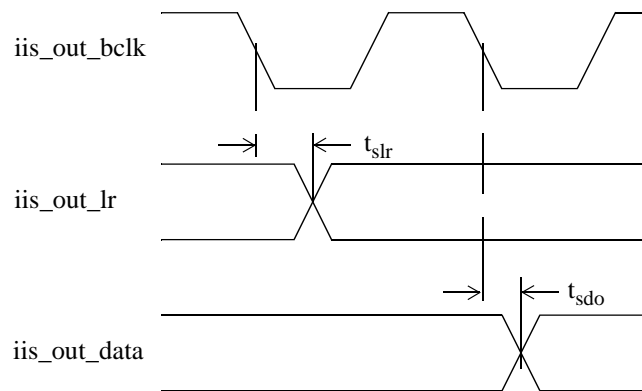
**Figure 6.5 IIS output timing measurement conditions****Table 6-12 IIS output timing parameters**

| Symbol    | Description                 | Min          | Max | Unit |
|-----------|-----------------------------|--------------|-----|------|
| $F_s$     | Output sample rate          | 32, 44.1, 48 |     | kHz  |
| $t_{slr}$ | SCLK falling to LRCLK delay | -10          | 10  | ns   |
| $t_{sdo}$ | SCLK falling to SDATA valid | -10          | 10  | ns   |

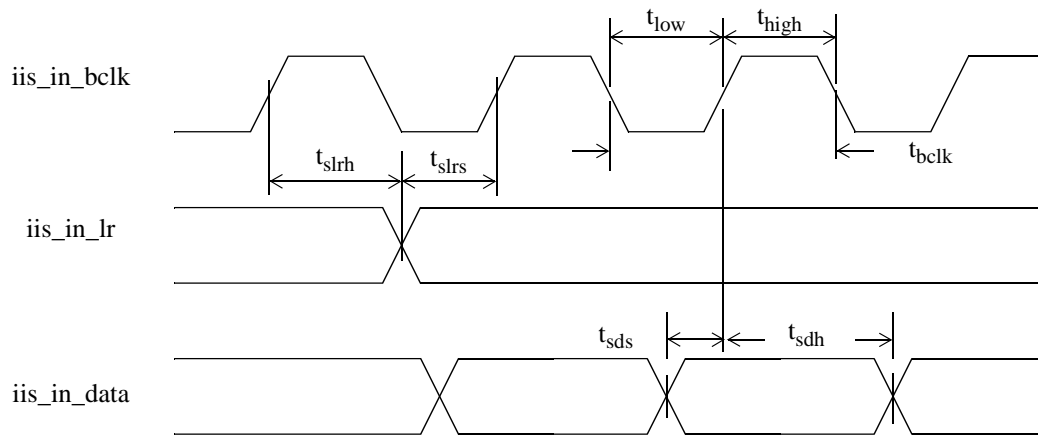

**Figure 6.6 IIS input timing measurement - slave mode**

**Table 6-13 IIS input timing parameters - slave mode**

| Symbol     | Description                      | Min            | Max | Unit       |
|------------|----------------------------------|----------------|-----|------------|
| $F_s$      | Input sample rate                | 32, 44.1, 48   |     | kHz        |
| $F_{mclk}$ | MCLK frequency                   | see Table 6-11 |     | From Table |
| $T_{bclk}$ | SCLK period                      | $8/F_{mclk}$   | -   | From Table |
| $T_{low}$  | SCLK pulse width low             | $2/F_{mclk}$   | -   | From Table |
| $T_{high}$ | SCLK pulse width high            | $2/F_{mclk}$   | -   | From Table |
| $t_{slrh}$ | SCLK rising to LRCLK hold        | 20             | -   | ns         |
| $t_{slrs}$ | SCLK rising to LRCLK setup       | 20             | -   | ns         |
| $t_{sds}$  | SDATA valid to SCLK rising setup | 20             | -   | ns         |
| $t_{sdh}$  | SCLK rising to SDATA hold time   | 20             | -   | ns         |

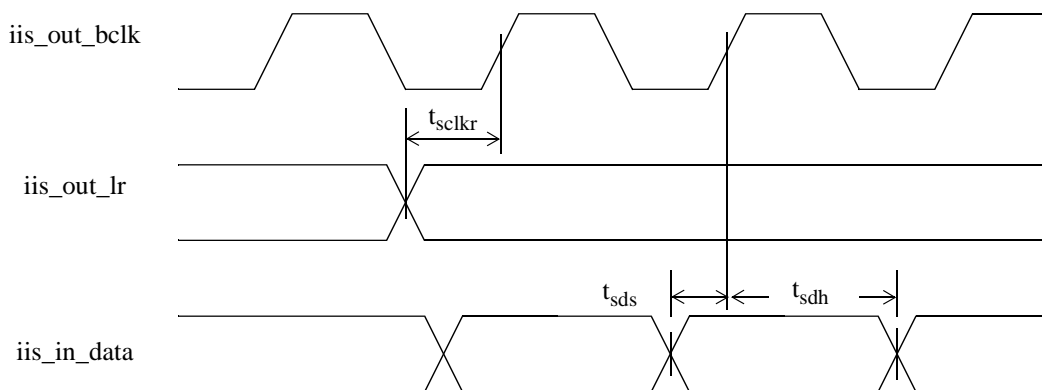

**Figure 6.7 IIS input timing measurement - master mode**

**Table 6-14 IIS input timing parameters - master mode**

| Symbol     | Description                      | Min               | Typical      | Max | Unit       |
|------------|----------------------------------|-------------------|--------------|-----|------------|
| $F_s$      | Input sample rate                | 32                | 44.1,        | 48  | kHz        |
| $F_{mclk}$ | MCLK frequency                   | see Table 6-11    |              |     | From Table |
| $T_{bclk}$ | SCLK period                      | $8/F_{mclk}$      | -            | -   | From Table |
| $t_{sclr}$ | SCLK rising to LRCLK edge        | -                 | $T_{bclk}/2$ | -   | $\mu s$    |
| $t_{sds}$  | SDATA valid to SCLK rising setup | $(1/F_{mclk})+10$ | -            | -   | ns         |
| $t_{sdh}$  | SCLK rising to SDATA hold        | $(1/F_{mclk})+15$ | -            | -   | ns         |

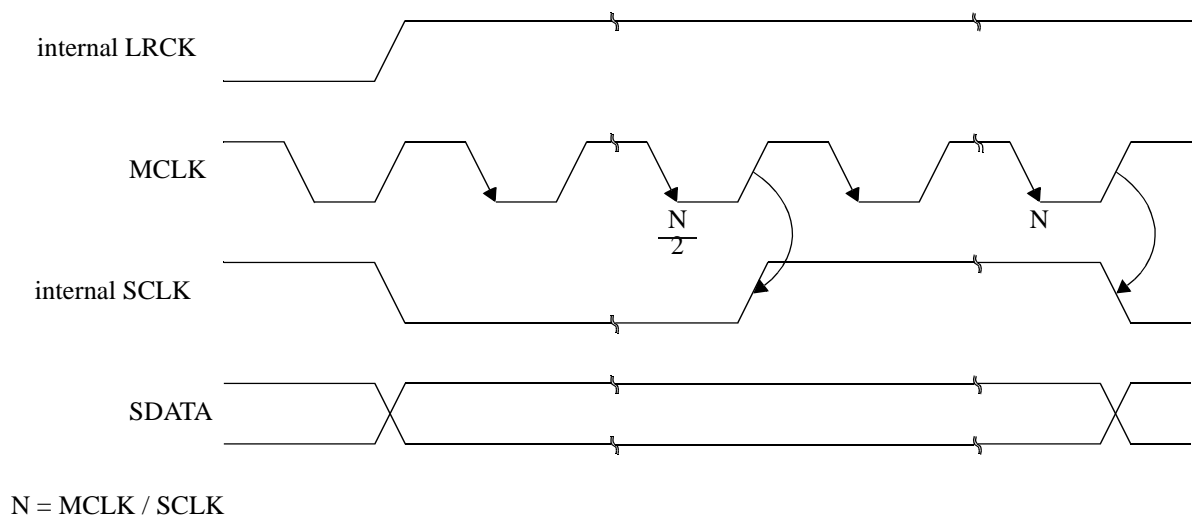
**Figure 6.8 Internal serial clock generation for IIS master**

## 6.4.6 Transport Channel Interface timing

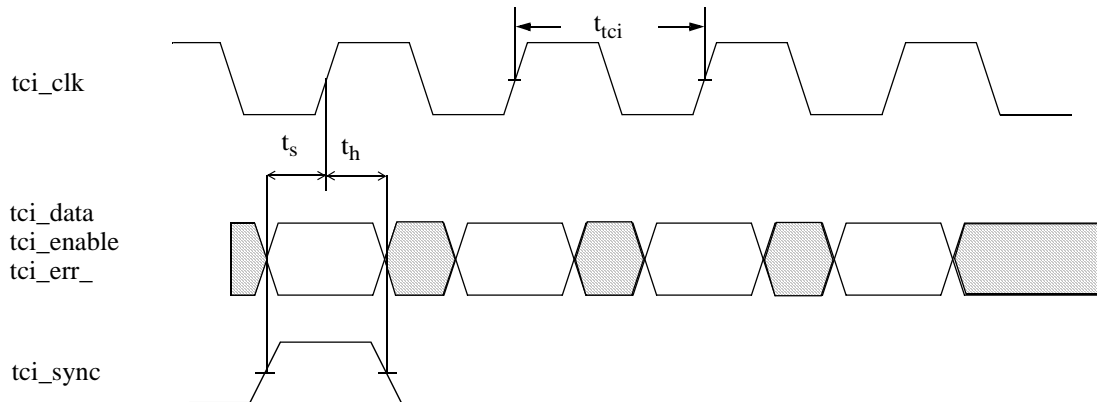

**Figure 6.9** TCI timing measurement conditions



The timing diagram and Table 6-15 are relevant to the primary TCI input port. Timing relationships, input setup, and hold times are identical for the secondary TCI input port. However, the `tci_vdac` output is not present on the secondary output port. Inputs `video_ina[9:0]` includes `tci_data[7:0]` (bits 7:0), `tci_enable` (bit 8), and `tci_err_` (bit 9)

**Table 6-15** TCI timing parameters

| Symbol    | Description                               | Min | Max                          | Unit |
|-----------|---|-----|------------------------------|------|
| $f_{tci}$ | TCI clock frequency <sup>a, b, c, d</sup> | -   | 27 (parallel)<br>80 (serial) | MHz  |
| $t_h$     | Hold time                                 | 1   | -                            | ns   |
| $t_s$     | Setup time                                | 4   | -                            | ns   |

- In parallel mode, it is required that  $t_{core} > f_{tci\_clk}$ .
- In serial mode, it is required that  $t_{core} > \frac{1}{2} f_{tci\_clk}$ .
- For correct audio clock counter operation,  $f_{core}/f_{audio} > 4$ , where  $f_{audio}$  is the frequency of `audioclk_out` produced by the on-chip PLL.
- For correct video clock counter operation,  $f_{core}/f_{video} > 4$ , where  $f_{video}$  is the frequency of `pclk`.

## 6.4.7 ITU-R BT.601/656 interface timing

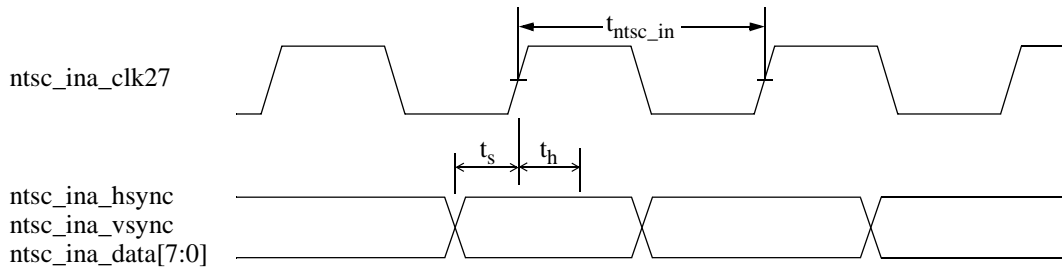

**Figure 6.10 ITU-R BT.601/656 input timing measurement**

**Table 6-16 ITU-R BT.601/656 input interface timing parameters**

| Symbol         | Description   | Min | Max | Unit |
|----------------|---|-----|-----|------|
| $f_{ntsc\_in}$ | NTSC input clock frequency  | -   |     | MHz  |
| $t_h$          | Input hold time for video_ina[9:0], from cross over of rising clock | 1   | -   | ns   |
| $t_s$          | Input setup time video_ina[9:0], to the cross over of rising clock  | 5   | -   | ns   |

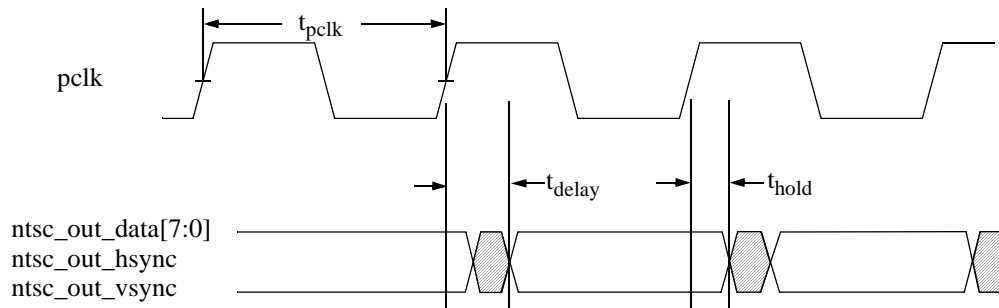

**Figure 6.11 ITU-R BT.601/656 output timing measurement**



This timing diagram and table include information for the primary video input port. The primary video input bus `video_ina[9:0]` includes the byte-wide data bus (bits 7:0), horizontal sync (bit 8), and vertical sync (bit 9). The secondary video input signals have identical timing relationships

**Table 6-17 ITU-R BT.601/656 output interface timing parameters**

| Symbol             | Description        | Min  | Max | Unit |
|--------------------|--------------------|------|-----|------|
| $t_{\text{pclk}}$  | pclk cycle time    | 18.5 | 37  | ns   |
| $t_{\text{delay}}$ | Maximum delay time | -    | 11  | ns   |
| $t_{\text{hold}}$  | Output hold time   | 4    | -   | ns   |

## 6.4.8 General Purpose Data Port

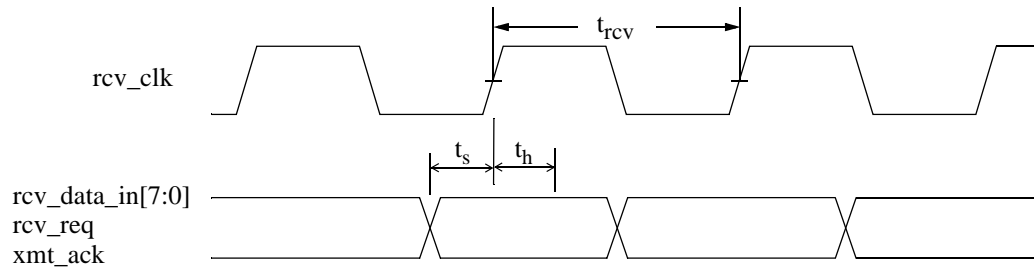
**Figure 6.12 GPDP input timing measurement conditions****Table 6-18 GPDP input timing parameters**

| Symbol           | Description              | Min | Max | Unit |
|------------------|--------------------------|-----|-----|------|
| $t_{\text{rcv}}$ | Receive clock cycle time | -   | 60  | MHz  |
| $t_{\text{h}}$   | Hold time                | 0   | -   | ns   |
| $t_{\text{s}}$   | Setup time               | 4   | -   | ns   |

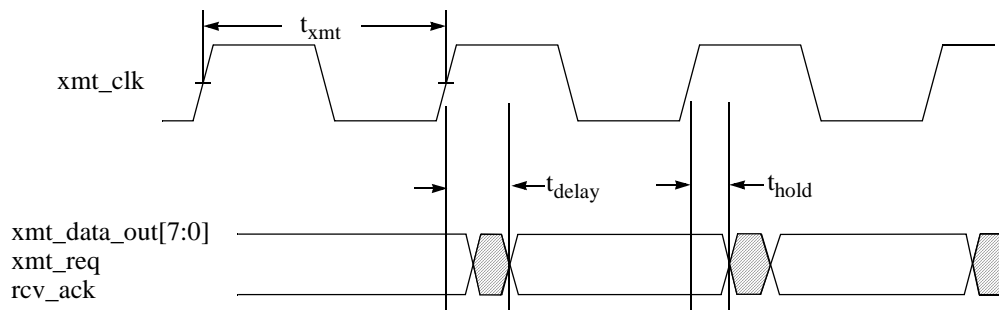
**Figure 6.13 GPDP output timing measurement conditions**



**Table 6-19 GPDP output timing parameters**

| Symbol      | Description               | Min | Max | Unit |
|-------------|---------------------------|-----|-----|------|
| $t_{xmt}$   | Transmit clock cycle time | -   | 60  | MHz  |
| $t_{hold}$  | Output hold time          | 3.0 | -   | ns   |
| $t_{delay}$ | Maximum delay time        | -   | 8   | ns   |

## 6.4.9 IIC interface timing

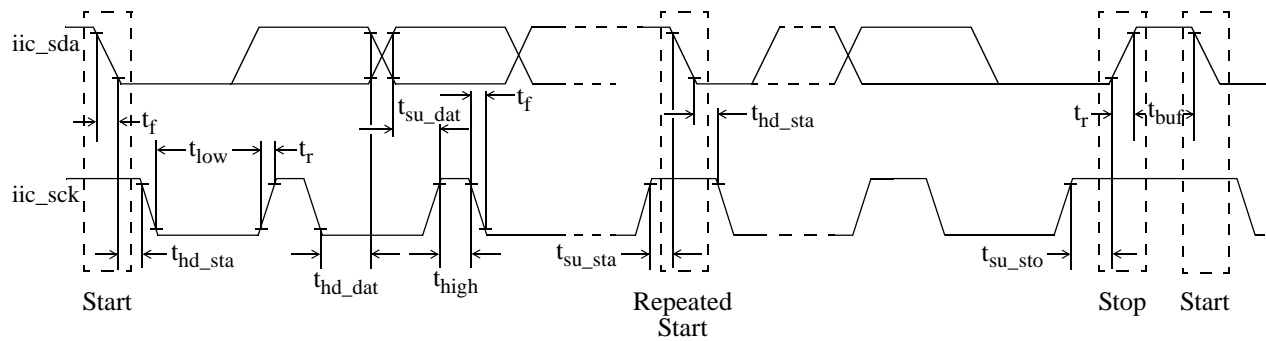
**Figure 6.14 IIC timing measurement conditions**

**Table 6-20 IIC interface timing parameters**

| Symbol <sup>a</sup> | Description  | Standard Mode  |      | Fast Mode       |     | Unit    |
|---------------------|--|----------------|------|-----------------|-----|---------|
|                     |  | Min            | Max  | Min             | Max |         |
| $f_{sck}$           | iic_sck clock frequency.   | 0              | 100  | 0               | 400 | kHz     |
| $t_{hd\_sta}$       | Hold time (repeated) START condition. After this period, the first clock pulse is generated. | 2.3            | -    | 0.57            | -   | $\mu$ s |
| $t_{low}$           | LOW period of the iic_sck clock.   | 4.7            | -    | 1.27            | -   | $\mu$ s |
| $t_{high}$          | HIGH period of the iic_sck clock.  | 4.0            | -    | 0.6             | -   | $\mu$ s |
| $t_{su\_sta}$       | Setup time for a repeated START condition.   | 4.7            | -    | 0.6             | -   | $\mu$ s |
| $t_{hd\_dat}$       | Data hold time.  | 0 <sup>b</sup> | 3.45 | 0 <sup>b</sup>  | 0.9 | $\mu$ s |
| $t_{su\_dat}$       | Data setup time.   | 250            | -    | 250             | -   | ns      |
| $t_r$               | Rise time of both iic_sda and iic_sck signals.   | -              | 1000 | $20 + 0.1C_b^c$ | 300 | ns      |
| $t_f$               | Fall time of both iic_sda and iic_sck signals.   | -              | 300  | $20 + 0.1C_b$   | 300 | ns      |
| $t_{su\_sto}$       | Setup time for STOP condition.   | 4.0            | -    | 0.6             | -   | $\mu$ s |
| $t_{buf}$           | Bus free time between a STOP and START condition.  | 4.7            | -    | 1.3             | -   | $\mu$ s |
| $C_b$               | Capacitive load for each bus line.   | -              | 400  | -               | 400 | pF      |

a. All values referred to  $V_{IHmin}$  and  $V_{ILmax}$  levels. See Table 6-4.

b. A device must internally provide a hold time of at least 300 ns for the SDA signal (referred to the  $V_{IHmin}$  of the SCL signal) to bridge the undefined region of the falling edge of SCL.

c.  $C_b$  = total capacitance of one bus line in pF.

## 6.4.10 dRGB timing

The BSP-15 generates all dRGB data signals on the rising edge of the pixelclk\_out clock output. An external device should latch the dRGB data with the falling edge of pixelclk\_out.

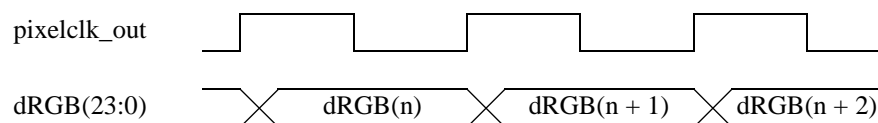
**Figure 6.15 dRGB timing diagram**

## 6.5 Termination Characteristics

### 6.5.1 Basic rules

This document specifies the proper termination for the BSP-15 DSP pins when specific blocks are not used. The basic rules are: float output pins; tie unused inputs to inactive level; special terminations are otherwise indicated.

#### 6.5.1.1 Weak pull down and pull up defined

The manufacturer assumes the use of a terminate with a 10 to 20 k $\Omega$  resistor for weakly pulling up or pulling down a pin.

## 6.5.2 Processor clock

**Table 6-21 Processor Clock Terminations**

| Pin Name        | Termination | Notes  |
|-----------------|-------------|--|
| pclk            | see notes   | supplies reference clock for the on-chip CORE/SDRAM, AUDIO, and PIXEL PLLs.  |
| coreclk_byp_in  | see notes   | CORE PLL uses this signal when the PLL is programmed to be in the bypass mode. It supplies the clock for the VLIW core. The CORE PLL comes out of reset in bypass mode, the bypass clock is needed during the booting phase, a clock input to this pin is ESSENTIAL. The manufacturer recommends tying the coreclk_byp_in and pclk together.   |
| sdclk_byp_in    | see notes   | SDRAM PLL uses this signal when the PLL is programmed to be in the bypass mode. It supplies the clock for the SDRAM interface. If the application will not use bypass mode, feed a slow frequency clock since this signal is used during the memory block reset phase (i.e., the chip reset phase), for some internal registers to be reset correctly. The clock needs to be fast enough to produce a couple of edges during the time when the chip is in reset. |
| pixelclk_byp_in | see notes   | PIXEL PLL uses the signal when the PIXEL PLL is programmed to be in the bypass mode. It supplies the pixel clock for DRC and VideoDAC. When not used, it can be weakly pulled down to ground. In BSP-15 DSP, this signal can also be optionally used for the ITU-R.BT 656_OUT block, as the output clock for the 8-bit parallel data port.   |
| audioclk_byp_in | see notes   | AUDIO PLL uses the signal when the AUDIO PLL is programmed to be in the bypass mode. It supplies the clock for the audio blocks. When not used, it can be weakly pulled down to ground.  |
| coreclk_out     | see notes   | This is the output of the core clock from the CORE PLL, used for debug. When not used, it can be left floating.  |
| pixelclk_out    | see notes   | This is the output of the pixel clock from the PIXEL PLL, used for debug. Leave floating when not used.  |
| audioclk_out    | see notes   | This is the output of the audio clock from the AUDIO PLL, used for debug. Leave floating when not used.  |

## 6.5.3 ROMCON

ROM shares I/O with other interfaces during normal operational mode.

**Table 6-22 ROMCOM Terminations**

| Pin Name | Termination | Notes |
|----------|-------------|-------|
| rom_ale# | floating    |       |
| rom_wrt  | floating    |       |
| rom_oe#  | floating    |       |
| rom_cs#  | floating    |       |

## 6.5.4 PCI

**Table 6-23 PCI Termination**

| Pin Name       | Termination         | Notes                               |
|----------------|---------------------|-------------------------------------|
| pci_ad[31..0]  | float               |                                     |
| pci_cbe[3..0]  | float               |                                     |
| pci_frame#     | weak pull up to Vdd |                                     |
| pci_trdy#      | weak pull up to Vdd |                                     |
| pci_irdy#      | weak pull up to Vdd |                                     |
| pci_stop#      | weak pull up to Vdd |                                     |
| pci_par        | float               |                                     |
| pci_devsel#    | weak pull up to Vdd |                                     |
| pci_clk        |                     | connect to low frequency clk signal |
| pci_rst#       |                     | chip reset                          |
| pci_inta#      | weak pull up to Vdd |                                     |
| pci_req[0]#    | weak pull up to Vdd |                                     |
| pci_gnt[0]#    | weak pull up to Vdd |                                     |
| pci_req[1]     | weak pull up to Vdd |                                     |
| pci_gnt[1]#    | weak pull up to Vdd |                                     |
| pci_req[2]     | weak pull up to Vdd |                                     |
| pci_gnt[2]#    | weak pull up to Vdd |                                     |
| pci_serr_intb# | weak pull up to Vdd |                                     |
| pci_idsel#     | weak pull up to Vdd |                                     |
| pci_pme#       | weak pull up to Vdd |                                     |

Versaport [22] should also have a weak pull-up to Vdd

## 6.5.5 ITU-R BT.601/656 out

**Table 6-24 ITU-R BT.601/656 Out Termination**

| Pin Name         | Termination | Notes   |
|------------------|-------------|---|
| tcia_vdac        | float       |   |
| ntsc_clk27_vcxo  | –           | shared with pclk  |
| ntsc_out_hsync   | float       |   |
| ntsc_out_vsync   | float       |   |
| ntsc_out_data[7] | see notes   | sw_strap (input, 4 pins): ..... Software straps for boot. These signal are also multiplexed with rom_data[7..4].<br><br>These straps may be used in any way desired. The manufacturer uses these straps to indicated to the software the type of board is in use.   |
| ntsc_out_data[6] | see notes   |   |
| ntsc_out_data[5] | see notes   |   |
| ntsc_out_data[4] | see notes   |   |
| ntsc_out_data[3] | float       |   |
| ntsc_out_data[2] | float       |   |
| ntsc_out_data[1] | see notes   | pci_host (input, 1 pin): ..... BSP-15 DSP is host on the primary PCI bus. This signal is multiplexed with rom_data[1].<br><br>When the BSP-15 DSP is the pci host, this pin should be weakly pulled up with a 4.7kΩ resistor. When the BSP-15 DSP is not the pci host, this pin should be weakly pulled down with a 4.7kΩ resistor. |
| ntsc_out_data[0] | see notes   | rom_boot (input, 1 pin): ..... Flash rom used for boot. This signal is multiplexed with rom_data[0].<br><br>When ROM boot is used, this pin should be weakly pulled up with a 4.7kΩ resistor. When PCI boot is used, this pin should be weakly pulled down with a 4.7kΩ resistor.   |

## 6.5.6 Video input ports

### 6.5.6.1 TCIA

**Table 6-25 TCIA Terminations**

| Pin Name                          | Termination      | Notes  |
|-----------------------------------|------------------|--|
| tcia_data[7..0] / video_ina[7..0] | weakly pull down |  |
| tcia_enable / video_ina[8]        | weakly pull down |  |
| tcia_sync                         | weakly pull down |  |
| tcia_err# / video_ina[9]          | weakly pull down |  |
| tcia_clk                          | weakly pull down |  |
| tcia_inuse                        | float            |  |
| tcia_vdac                         | float            | The pin is the simulated sigma delta output that controls the software PLL loop that tracks the transport encoder video clock. The pin is shared by the TCIA and TCIB block. |

### 6.5.6.2 TCIB

**Table 6-26 TCIA Terminations**

| Pin Name                          | Termination      | Notes                |
|-----------------------------------|------------------|----------------------|
| tcib_data[7..0] / video_ina[7..0] | weakly pull down |                      |
| tcib_enable / video_ina[8]        | weakly pull down |                      |
| tcib_sync                         | weakly pull down |                      |
| tcib_err# / video_ina[9]          | weakly pull down |                      |
| tcib_clk                          | weakly pull down |                      |
| tcib_inuse                        | float            |                      |
| tcib_vdac                         | float            | See tcia_vdac above. |

### 6.5.7 ITU-R BT.601/656 IN\_A

**Table 6-27 ITU-R BT.601/656 IN\_A Terminations**

| Pin Name                              | Termination      | Notes |
|---------------------------------------|------------------|-------|
| ntsc_ina_data[7..0] / video_ina[7..0] | weakly pull down |       |
| ntsc_ina_hsync / video_ina[8]         | weakly pull down |       |
| ntsc_ina_vsync / video_ina[9]         | weakly pull down |       |
| ntsc_ina_clk27                        | weakly pull down |       |

### 6.5.8 ITU-R BT.601/656 IN\_B

**Table 6-28 ITU-R BT.601/656 IN\_B Terminations**

| Pin Name                              | Termination      | Notes |
|---------------------------------------|------------------|-------|
| ntsc_inb_data[7..0] / video_inb[7..0] | weakly pull down |       |
| ntsc_inb_hsync / video_inb[8]         | weakly pull down |       |
| ntsc_inb_vsync / video_inb[9]         | weakly pull down |       |
| ntsc_inb_clk27                        | weakly pull down |       |

### 6.5.9 IIS

**Table 6-29 IIS Terminations**

| Pin Name                    | Termination      | Notes |
|-----------------------------|------------------|-------|
| iis_in_data                 | weakly pull down |       |
| iis_in_lr                   | weakly pull down |       |
| iis_in_bclk                 | weakly pull down |       |
| iis_out_data[2..0]          | float            |       |
| iis_out_mclk / audioclk_out | float            |       |
| iis_out_lr                  | float            |       |
| iis_out_bclk                | float            |       |

## 6.5.10 IEC958

**Table 6-30 IEC 958 Terminations**

| Pin Name   | Termination      | Notes |
|------------|------------------|-------|
| iec958_out | float            |       |
| iec958_in  | weakly pull down |       |

## 6.5.11 IIC/DDC

**Table 6-31 IIC/DDC Terminations**

| Pin Name   | Termination      | Notes |
|------------|------------------|-------|
| iic_sda    | weakly pull down |       |
| iic_sck    | weakly pull down |       |
| ddc_select | float            |       |

## 6.5.12 JTAG

**Table 6-32 JTAG Terminations**

| Pin Name | Termination      | Notes |
|----------|------------------|-------|
| tck      | weakly pull down |       |
| tms      | weakly pull down |       |
| tdi      | weakly pull down |       |
| trst     | weakly pull down |       |
| tdo      | float            |       |

## 6.5.13 DRC / VideoDAC

**Table 6-33 DRC / VideoDAC**

| Pin Name       | Termination              | Notes                  |
|----------------|--------------------------|------------------------|
| vsync          | float                    |                        |
| hsync          | float                    |                        |
| gdac_comp      | Vref, weakly pull down   |                        |
| gdac_fsacle    | tie to ground            |                        |
| gdac_green     | weakly pull up to VddI/O |                        |
| gdac_blue      | weakly pull up to VddI/O |                        |
| gdac_red       | weakly pull up to VddI/O |                        |
| aVdd_DAC (D16) | tie to VddI/O            | no extra filter needed |
| aVddx (D17)    | tie to VddI/O            | no extra filter needed |
| aVss (A17)     | tie to ground Vss        |                        |



**Table 6-33 DRC / VideoDAC**

| <b>Pin Name</b> | <b>Termination</b> | <b>Notes</b> |
|-----------------|--------------------|--------------|
| aVssx (B19)     | tie to ground Vss  |              |
| gdac_cvgg (C18) | tie to ground Vss  |              |

A PIO bit in the DRC controls the VideoDAC powerdown



---

# Chapter 7 Thermal Specifications

---

Thermal parameters are shown in Table 7-1. Note that  $\theta_{JA}$  can be improved by providing either passive or active cooling.

**Table 7-1 Thermal Parameters**

| Symbol        | Parameter   | Min | Max  | Unit |
|---------------|---|-----|------|------|
| $T_C$         | Operating Case Temperature <sup>a</sup>             | 0   | 85   | °C   |
| $T_J$         | Operating Junction Temperature                      |     | 105  | °C   |
| $\theta_{JA}$ | Thermal Resistance Junction to Ambient <sup>b</sup> |     | 11.4 | °C/W |

a. Measured at top center of case surface with the device soldered to circuit board

b. Values are for 0 [ft/min] airflow



# Chapter 8 Mechanical Specifications

## 8.1 EBG352 Package

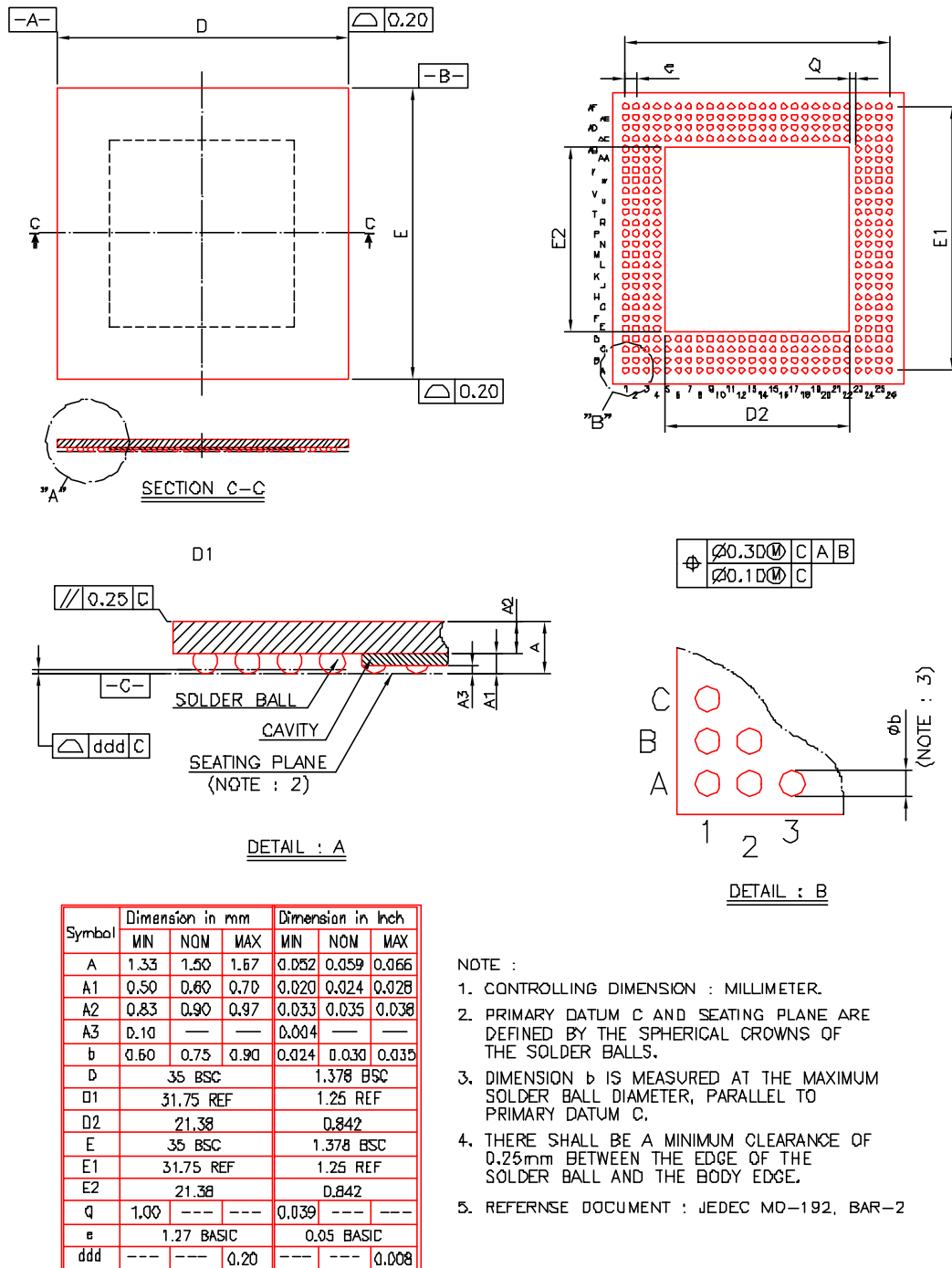

Figure 8.1 EBG352 Package

## 8.2 Package Materials

**Table 8-1 Materials specification**

| Segment           | Material          |
|-------------------|-------------------|
| Package substrate | BT Resin          |
| Encapsulation     | Epoxy with filler |
| Heat Spreader     | Cu + Ni plating   |
| Solder Ball       | 37 Pb - 63 Sn     |



The package shown here is the MAP-CA DSP pin-compatible package. Other packaging options are available. Please contact Equator Technologies, Inc. sales representatives for details.

---

# Appendix A      Glossary

---

These acronyms and names used in this *Data Sheet*. These are their expansion or explanation.

|                                 |  |
|---------------------------------|--|
| aRGB .....                      | analog RGB   |
| BSDL .....                      | Boundary Scan Description Language   |
| DataStreamer DMA controller ... | High speed DMA controller that operates independent from VLIW core, also referred to as the DS DMA controller      |
| DRC .....                       | Display Refresh Controller   |
| dRGB .....                      | digital RGB  |
| DS DMA controller .....         | the DataStreamer DMA controller  |
| DTS.....                        | Data Transfer Switch - high speed BSP-15 series internal data bus  |
| FEC .....                       | Forward error correction   |
| I-ALU .....                     | Integer ALU (Arithmetic Logic Unit) - performs loads, stores, branches, integer arithmetic, and logical operations |
| IG-ALU.....                     | Integer, Graphics unit - performs integer arithmetic and (partitioned) multimedia operations                       |
| MMU.....                        | Memory Management Unit   |
| PLC .....                       | 128-bit Partitioned Local Constant register  |
| PLV .....                       | 128-bit Partitioned Local Variable register  |
| SIMD .....                      | Single Instruction Multiple Data   |
| TLB.....                        | Translation Lookaside Buffer   |
| VLx .....                       | A coprocessor that can accelerate variable length encoding and variable length decoding.                           |

