

THESE HIGH-VOLTAGE, HIGH-CURRENT

Darlington arrays are comprised of seven silicon NPN darlington pairs on a common monolithic substrate. All units have open-collector outputs and integral diodes for inductive load transient suppression.

ULN2003 has a 2.7 kΩ series base resistor for each darlington pair, allowing operation directly with TTL or CMOS operating at a supply voltage of 5 V. These devices will handle numerous interface needs particularly those beyond the capabilities of standard logic buffers.

ULN2004 has a 10.5 kΩ series input resistor that permits operation directly from CMOS or PMOS outputs utilizing supply voltages of 6 to 15 V.

ULN2003/ULN2004 is the original high-voltage, high-current darlington array. The output transistors are capable of sinking 500 mA and will sustain at least 50 V in the off state. Output may be paralleled for higher load-current capability.

ULN2003/ULN2004 darlington arrays are furnished in a 16-Pin dual in-line plastic package. These can also be supplied in a hermetic dual in-line package for use in military and aerospace applications.

DEVICE NUMBER DESIGNATION

VCE(MAX)	50V
IC(MAX)	500mA

Logic	Type Number
5V TTL, CMOS	ULN2003
6-15V CMOS, PMOS	ULN2004

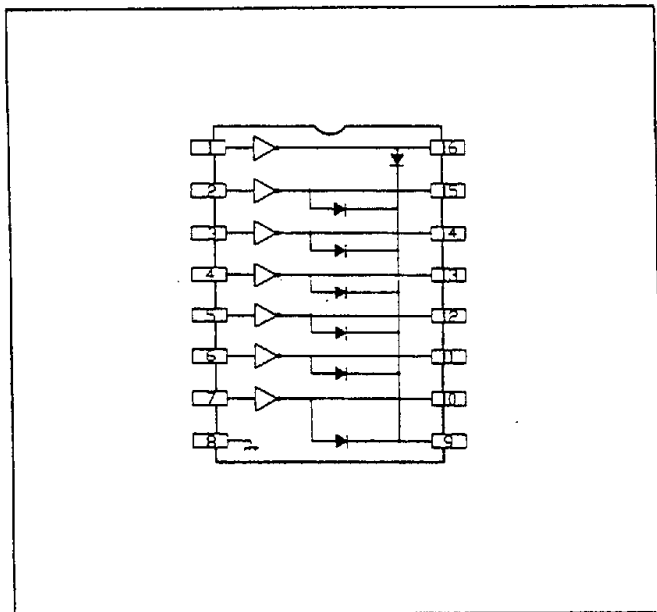

ALLOWABLE AVERAGE POWER DISSIPATION AS A FUNCTION OF AMBIENT TEMPERATURE

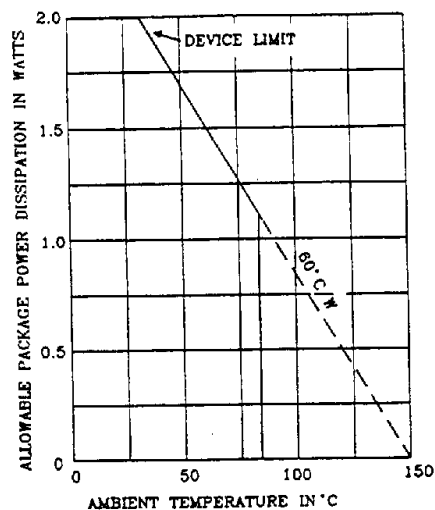

ABSOLUTE MAXIMUM RATINGS

at +25 °C Free - Air Temperature
(unless otherwise noted)

Input Voltage, V_{IN} (ULN2003, ULN2004)	30 V
Continuous Input Current, I_{IN}	25 mA
Power Dissipation, P_D (one Darlington pair)	1.0 W
(total package)	2.0 W*
Operating Ambient Temperature Range, T_A	-20 °C to +85 °C
Storage Temperature Range, T_S	-55 °C to +150 °C

* Debate at the rate of 16.67 mW/°C above +25 °C.

Under normal operating conditions, these devices will sustain 350 mA per output with $V_{CE(STA)} = 1.6$ V at +70 °C with a pulse width of 20 ms and a duty cycle of 34%.

PARTIAL SCHEMATICS

Series ULN2003
(each driver)

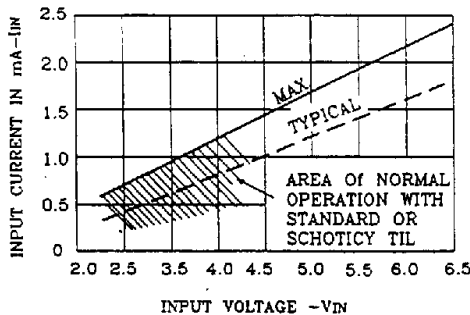

Series ULN2004
(each driver)

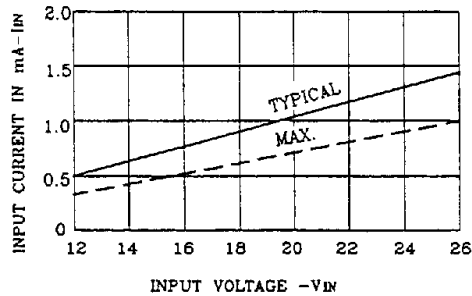

PEAK COLLECTOR CURRENT AS A FUNCTION OF DUTY CYCLE

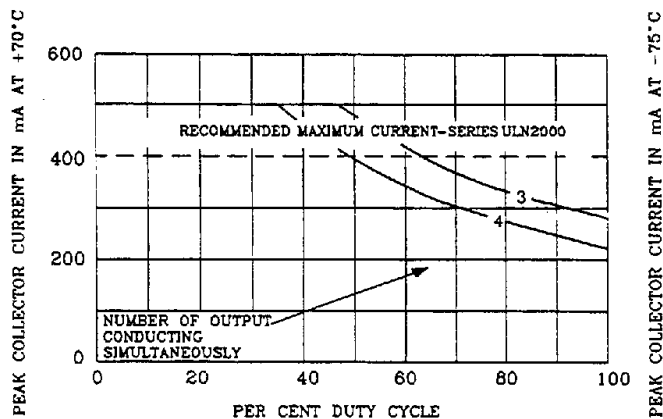

ELECTRICAL CHARACTERISTICS AT +25°C (unless otherwise noted)

Characteristic	Symbol	Test Fig.	Applicable Devices	Test Conditions	Limits				
					Min.	Typ.	Max.	Units	
Output Leakage Current	I_{CEX}	1A	All	$V_{CE}=50V, T_A=25^\circ C$	—	—	50	μA	
				$V_{CE}=50V, T_A=70^\circ C$	—	—	100	μA	
		1B	ULN2004	$V_{CE}=50V, T_A=70^\circ C, V_{IN}=1.0V$	—	—	500	μA	
Collector - Emitter Saturation Voltage	$V_{CE(SAT)}$	2	All	$I_C=100mA, I_S=250\mu A$	—	0.9	1.1	V	
				$I_C=200mA, I_S=350\mu A$	—	1.1	1.3	V	
				$I_C=350mA, I_S=500\mu A$	—	1.3	1.6	V	
Input Current	$I_{IN(ON)}$	3	ULN2003	$V_{IN}=3.85V$	—	0.93	1.35	mA	
				ULN2004	$V_{IN}=5.0V$	—	0.35	0.5	mA
					$V_{IN}=12V$	—	1.0	1.45	mA
Input Voltage	$V_{IN(ON)}$	4	All	$I_C=500\mu A, T_A=70^\circ C$	50	65	—	μA	
				5	ULN2003	$V_{CE}=2.0V, I_C=200mA$	—	—	2.4
		$V_{CE}=2.0V, I_C=250mA$	—			—	2.7	V	
		ULN2004	$V_{CE}=2.0V, I_C=300mA$		—	—	3.0	V	
			$V_{CE}=2.0V, I_C=125mA$		—	—	5.0	V	
			$V_{CE}=2.0V, I_C=200mA$		—	—	6.0	V	
		5	ULN2004	$V_{CE}=2.0V, I_C=275mA$	—	—	7.0	V	
$V_{CE}=2.0V, I_C=350mA$	—			—	8.0	V			
Input Capacitance	C_{IN}	—	All	—	—	15	25	pF	
Turn-On Delay	t_{PLH}	—	All	$0.5 E_{in}$ to $0.5 E_{out}$	—	0.25	1.0	μS	
Turn-Off Delay	t_{PHL}	—	All	$0.5 E_{in}$ to $0.5 E_{out}$	—	0.25	1.0	μS	
Clamp Diode Leakage Current	I_R	6	All	$V_R=50V, T_A=25^\circ C$	—	—	50	μA	
				$V_R=50V, T_A=70^\circ C$	—	—	100	μA	
Clamp Diode Forward Voltage	V_F	7	All	$I_F=350mA$	—	1.7	2.0	V	

COLLECTOR CURRENT AS A FUNCTION OF SATURATION VOLTAGE

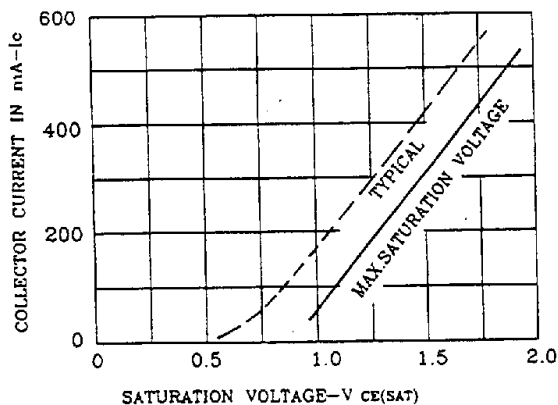

COLLECTOR CURRENT AS A FUNCTION OF INPUT CURRENT

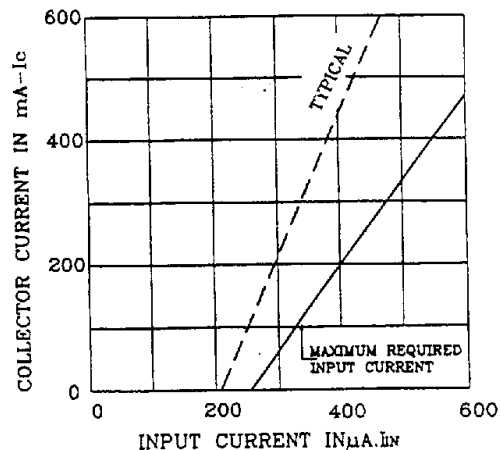

INPUT CURRENT AS A FUNCTION OF INPUT VOLTAGE

SERIES ULN2003

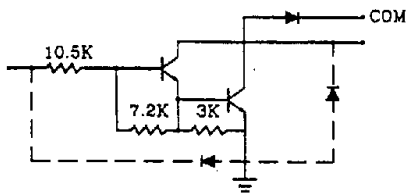

SERIES ULN2004

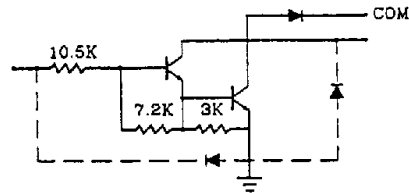

TTL TO LOAD

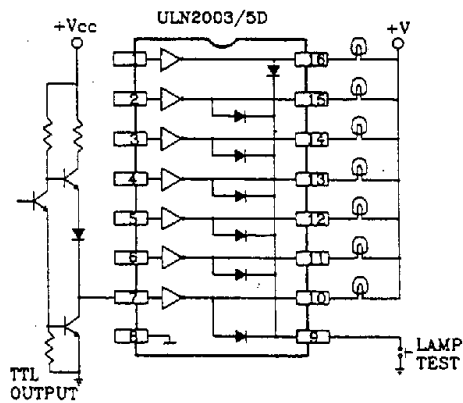

USE OF PULL-UP RESISTORS TO INCREASE DRIVE CURRENT

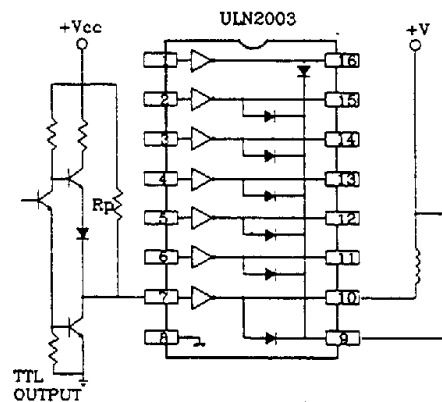

BUFFER FOR HIGH-CURRENT LOAD

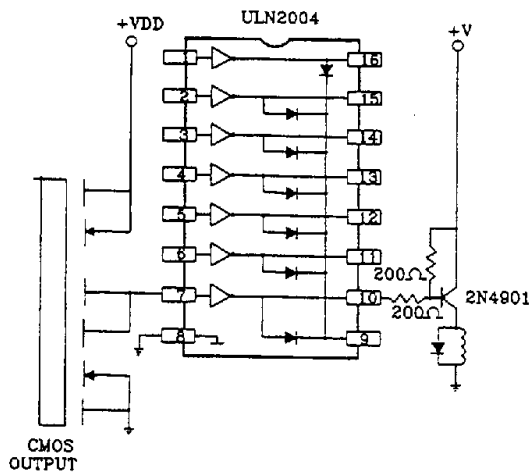

TEST FIGURES

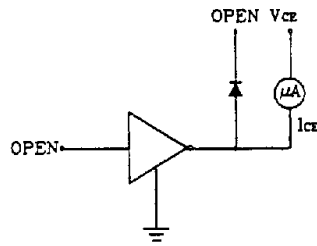

FIGURE 1A

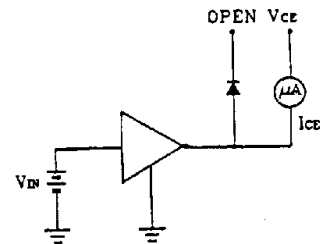

FIGURE 1B

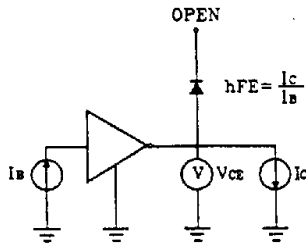

FIGURE 2

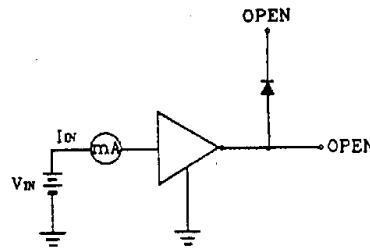

FIGURE 3

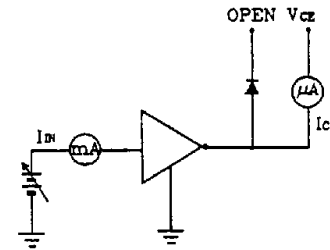

FIGURE 4

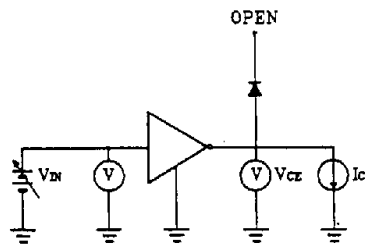

FIGURE 5

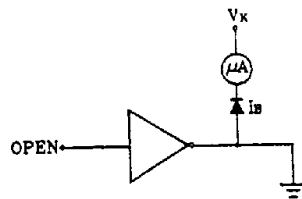

FIGURE 6

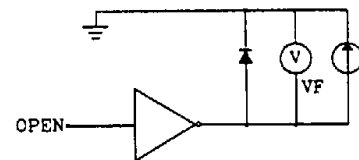

FIGURE 7