

M/A-COM Cellular CDMA Upconverter / Driver 820 - 850 MHz

Features

- Highly integrated upconverter and driver amplifier
- High linear output power, +5 dBm
- Variable gain control
- Low LO drive level, -5 dBm
- Single 3.0 V supply
- Miniature 5 mm MLF plastic package

Description

M/A-COM's MD59-0039 upconverter IC for cellular CDMA applications integrates a mixer, RF amplifier, IF amplifier, and LO buffer in a 5 millimeter (mm) square plastic micro lead-frame package with exposed back side for improved high frequency grounding.

M/A-COM designed the MD59-0039 to operate with balanced IF inputs and a single-ended RF output with a frequency in the 800 to 900 MHz frequency band. The maximum conversion gain is 24 dB, with a minimum 15 dB of gain range. The MD59-0039 can produce 5 dBm of linear output power, with an associated ACPR of -56 dBc (IS-98). An internal LO buffer amplifier allows the device to accommodate low LO drive levels in the range of -10 dBm to -5 dBm.

M/A-COM fabricates the MD59-0039 using a 0.5 micron low noise GaAs MESFET process. The process features full passivation for increased performance and reliability.

Functional Block Diagram

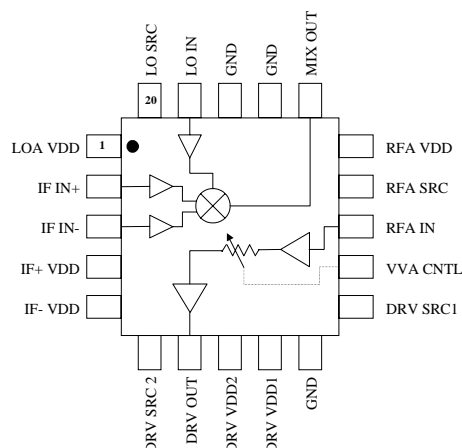

Ordering Information

Part Number	Package
MD59-0039	MLF-5.0 mm Plastic Package
MD59-0039TR	Forward Tape and Reel ¹
MD59-0039RTR	Reverse Tape and Reel ¹

1. If specific reel size is required, consult factory for part number assignment.

Electrical Specifications $T_A = +25^\circ\text{C}$, $V_{DD} = 3.0\text{ Volts}$

Parameter	Test Conditions	Units	Min.	Typ.	Max.
Cascaded Performance					
RF Frequency		MHz	820		850
Conversion Gain	Frequency = 836 MHz, $P_{IN} = -15\text{ dBm}$	dB		24	
Linear Output Power @ ACPR of -56 dBc (IS-98)		dBm		+5.0	
Gain Range		dB		15	
Port Matches (all ports)		dB	10		
LO-to-RF Isolation		dB		40	
LO-to-IF Isolation		dB		30	
RF-to-IF Isolation		dB		20	
I_{DD}		mA		80	

Specifications subject to change without notice.

V 2.0

- North America: Tel. (800) 366-2266, Fax (800) 618-8883
- Asia/Pacific: Tel.+81-44-844-8296, Fax +81-44-844-8298
- Europe: Tel. +44 (1344) 869 595, Fax+44 (1344) 300 020

Visit www.macom.com for additional data sheets and product information.

tyco / Electronics

M/A-COM

Electrical Specifications $T_A = +25^\circ\text{C}$, $V_{DD} = 3.0\text{ Volts}$ (Cont'd)

Parameter	Test Conditions	Units	Min.	Typ.	Max.
IF Input					
IF Frequency		MHz		130	
IF Input Level		dBm			-16
IF Impedance	Balanced	ohms		265	
LO Input					
LO Frequency		MHz	954		979
LO Input Level		dBm	-10	-5	0

Operating Instructions

The MD59-0039 is a highly integrated MMIC upconverter for the 800 – 900 MHz cellular band. The upconverter provides exceptional RF performance while drawing low DC current and is packaged in a low cost plastic package. It is an ideal candidate for light-weight, battery operated, portable handset applications.

The MD59-0039 incorporates a differential IF amplifier, balanced mixer, LOA, RFA, variable voltage attenuator and a two-stage driver amplifier. Surface mount resistors, inductors and capacitors are used in conjunction with the MMIC to optimize the trade-offs between performance, tunability and ease of use. The schematic on the previous page shows the MMIC and required off-chip component values.

The input impedance of the differential IF amplifier is matched externally to $50\ \Omega$ at the desired IF frequency with L1, C1 and C2. In addition, C1 and C2 also act as DC blocking capacitors for the differential IF inputs. A 06-03 case style can be used for L1 in most cases, but a 08-05 case style can be used if more gain is required. Capacitor C3 is a low frequency bypass capacitor. Inductors L2 and L3 help match the output of the differential IF amplifier to the differential input of the mixer, as well as providing RF chokes for the DC supply lines.

The LO input port is matched on chip to $50\ \Omega$. The LO buffer amplifier provides the voltage gain required to drive the gate of the mixer FET, while drawing a minimal amount of current. The LO buffer amplifies the $-10\ \text{dBm}$ input signal to the level required to drive the mixer. For optimum performance, it is recommended to use a drive level of $-3\ \text{dBm}$. C7 and C14 are RF and low frequency bypass capacitors for the DC supply line. Capacitor C13 is a source bypass capacitor for the LO amplifier. The position of both C7 and C13 shown in the application circuit may affect the gain of the RF amplifier and should be placed as close the device as is practical.

The mixer is a balanced floating FET mixer that provides exceptional linearity and isolation with low loss and no DC current. The mixer uses a high side LO frequency. An external

image reject filter is required between the mixer output and RFA input to prevent upconversion noise at the image frequency from leaking onto the RF. This filter should have $50\ \Omega$ input and output impedance.

The topology of both the input and output matching networks for the RF amplifier provides internal DC blocking capacitors, to prevent unwanted DC leakage. C6 and C12 are RF and low frequency bypass capacitors for the DC supply line. Capacitor C11 is a source bypass capacitor for the RF amplifier. Similar to the LOA, C11 and C12 should be placed as close the device as is practical. The VVA is a T-attenuator topology, providing better than 30 dB of attenuation from 800 to 900 MHz.

The two-stage driver amplifier is nominally biased with 40 mA. An external resistor, R1, can be used to adjust the bias current of the second stage, thereby adjusting the linear output power. C4, C5, C9 and C10 are RF and low frequency bypass capacitors for the DC supply lines, for the first and second stage of the driver respectively. Capacitors C8 and C16 are the source bypass capacitors for the driver amplifier.

Specifications subject to change without notice.

V 2.0

■ North America: Tel. (800) 366-2266, Fax (800) 618-8883
 ■ Asia/Pacific: Tel.+81-44-844-8296, Fax +81-44-844-8298
 ■ Europe: Tel. +44 (1344) 869 595, Fax+44 (1344) 300 020

Visit www.macom.com for additional data sheets and product information.

tyco / Electronics

MACOM

2

Recommended PCB Configuration

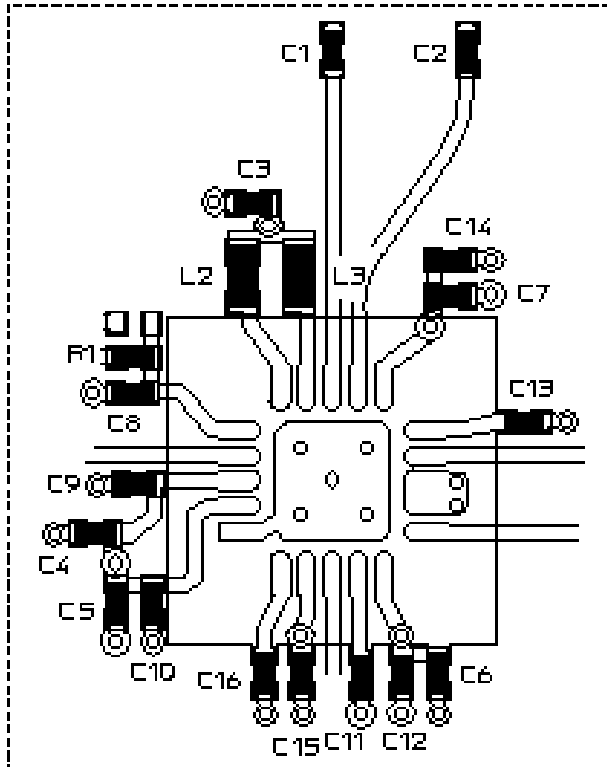

Pin Configuration

Pin #	Pin Name	Description
1	LOA V _{DD}	LO amplifier supply voltage. RF bypassing required
2	IF+ IN	RF input to differential IF amplifier. DC blocked
3	IF- IN	RF input to differential IF amplifier. DC blocked
4	IF+ V _{DD}	Differential IF amplifier supply voltage. RF bypassing required
5	IF- V _{DD}	Differential IF amplifier supply voltage. RF bypassing required
6	DRV SRC2	Source of RFA output stage FET. Off-chip resistor may be used for current control. RF bypassing required
7	DRV OUT	50 ohm output of driver amplifier
8	DRV V _{DD2}	2 nd stage driver amplifier supply voltage. RF bypassing required
9	DRV V _{DD1}	1 st stage driver amplifier supply voltage. RF bypassing required
10	GND	DC and RF ground
11	DRV SRC1	1 st stage source of driver amplifier. RF bypassing required
12	VVA CNTRL	Control voltage input to voltage variable attenuator
13	RFA IN	50 ohm input of RF amplifier
14	RFA SRC	Source of RF amplifier. RF bypassing required
15	RFA V _{DD}	RF amplifier supply voltage. RF bypassing required
16	MIX OUT	RF output of downconverter
17	GND	DC and RF ground
18	GND	DC and RF ground
19	LO IN	Local oscillator Input (-5 dBm typical)
20	LO SRC	Source of LO amplifier. RF bypassing required

Specifications subject to change without notice.

V 2.0

■ North America: Tel. (800) 366-2266, Fax (800) 618-8883
 ■ Asia/Pacific: Tel.+81-44-844-8296, Fax +81-44-844-8298
 ■ Europe: Tel. +44 (1344) 869 595, Fax+44 (1344) 300 020

Visit www.macom.com for additional data sheets and product information.

tyco / Electronics

MACOM

Sample Board Schematic

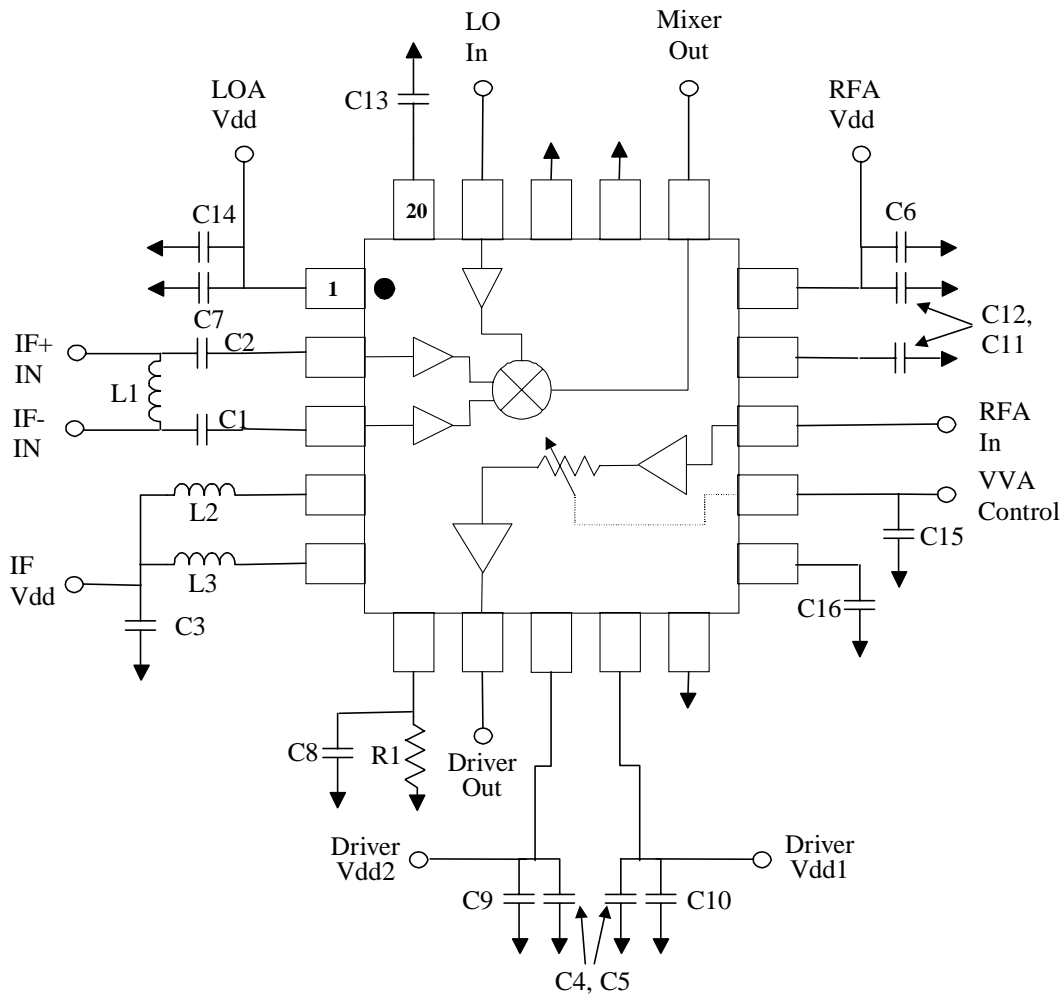

External Circuitry Parts List

Ref. Designation	Value	Purpose
L1	270 nH	IF match
L2, L3	68 nH	IF match
C3, C4, C5, C6, C7	1000 pF	RF bypass
C8, C9, C10, C11, C12, C13, C14	150 pF	RF bypass
C1, C2	1000 pF	IF matching
C16	15 pF	RF bypass
C15	47 pF	RF bypass
R1	33 ohm	Current control from driver 2 nd stage

Specifications subject to change without notice.

V 2.0

■ North America: Tel. (800) 366-2266, Fax (800) 618-8883
 ■ Asia/Pacific: Tel.+81-44-844-8296, Fax +81-44-844-8298
 ■ Europe: Tel. +44 (1344) 869 595, Fax+44 (1344) 300 020

Visit www.macom.com for additional data sheets and product information.

tyco / Electronics

MACOM

Typical Performance Curves

Conversion Gain vs. VVA CNTRL, T = -30° C, LO=-5dBm, IF=-15dBm, VBatt and VR5=3.0V

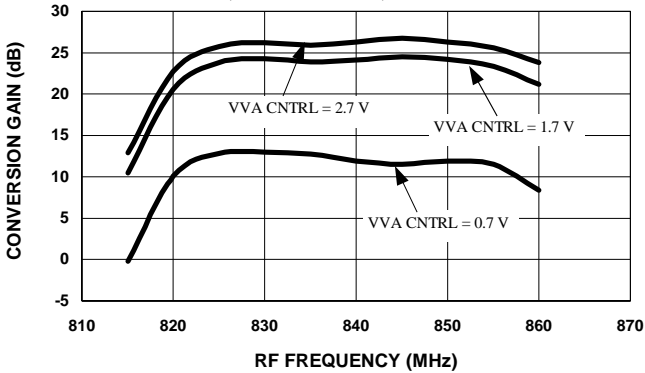

Conversion Gain vs. VVA CNTRL, T = +85° C, LO=-5dBm, IF=-15dBm, VBatt and VR5=3.0V

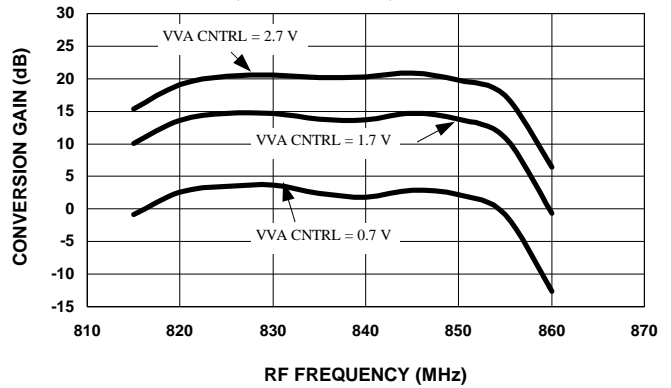

Conversion Gain vs. VVA CNTRL, T = +25° C, LO=-5dBm, IF=-15dBm, VBatt and VR5=3.0V

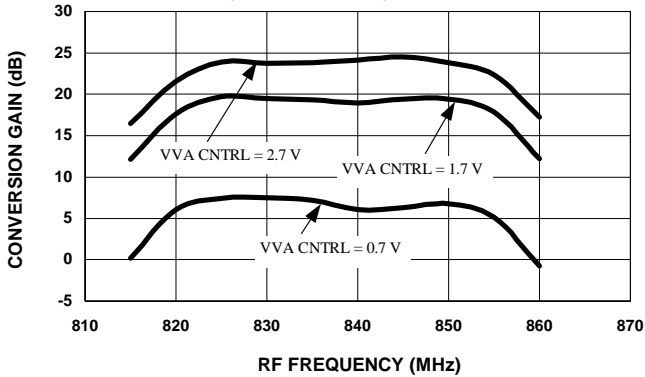

Conversion Gain vs. Temperature, VVA CNTRL=0.7V, LO=-5dBm, IF=-15dBm, VBatt and VR5 = 3.0V

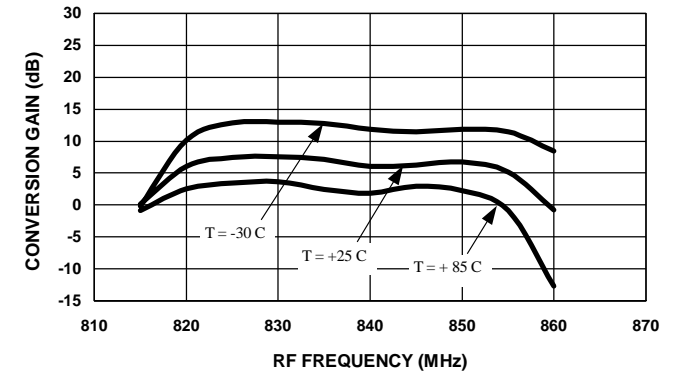

Conversion Gain vs. Temperature, VVA CNTRL=1.7V, LO=-5dBm, IF=-15dBm, VBatt and VR5 = 3.0V

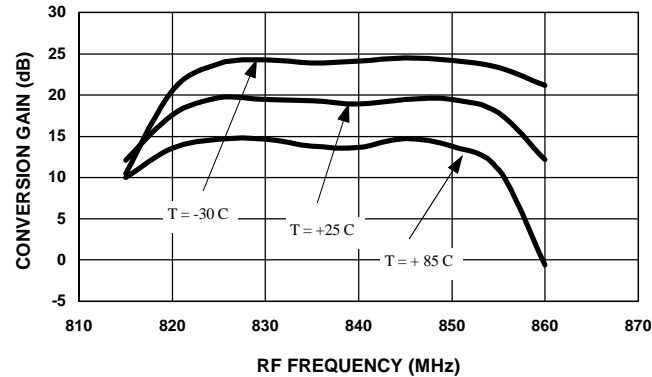

Conversion Gain vs. Temperature, VVA CNTRL=2.7V, LO=-5dBm, IF=-15dBm, VBatt and VR5 = 3.0V

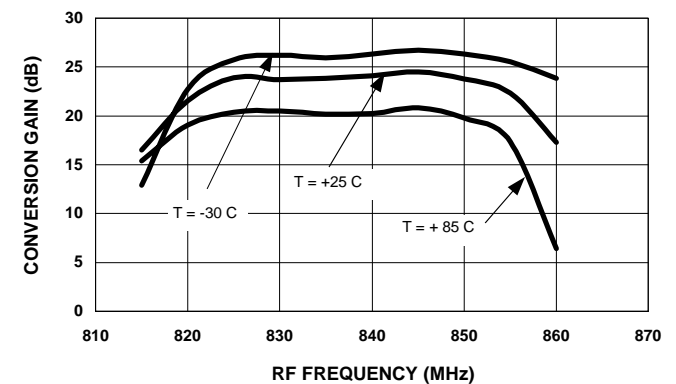

Specifications subject to change without notice.

V.2.0

- North America: Tel. (800) 366-2266, Fax (800) 618-8883
- Asia/Pacific: Tel.+81-44-844-8296, Fax +81-44-844-8298
- Europe: Tel. +44 (1344) 869 595, Fax+44 (1344) 300 020

Visit www.macom.com for additional data sheets and product information.



Typical Performance Curves (Cont'd)

Conversion Gain vs. VVA CNTRL Over Temperature, RF Frequency = 835 MHz, LO=-5dBm, IF=-15dBm, VBatt and VR5=3.0V

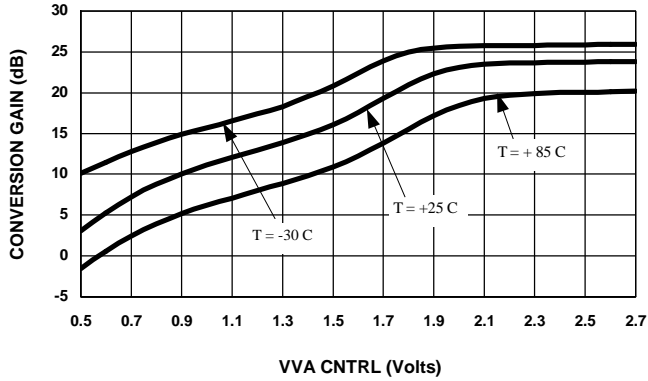

LO_IN to MIX_OUT Isolation Over Temperature, LO = -5dBm, VBatt and VR5 = 3.0V

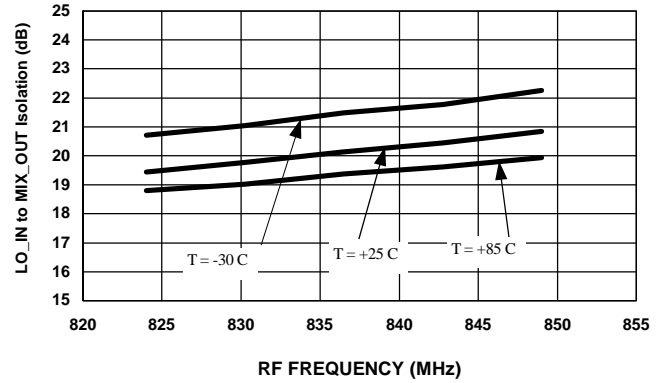

ACPR vs. Frequency Over Temperature Linear Output @ ACPR = -56dBc, LO=-5 dBm IF=-15dBm (-14dBm @ COLD), VBatt and VR5=3.0V

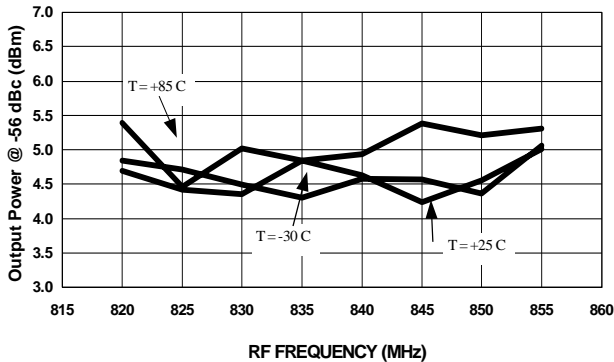

Linear Output Power vs. VVA_CNTRL, Over Temperature, LO=-5dBm, IF=-15dBm (-14 dBm @ COLD), VBatt and VR5 = 3.0V

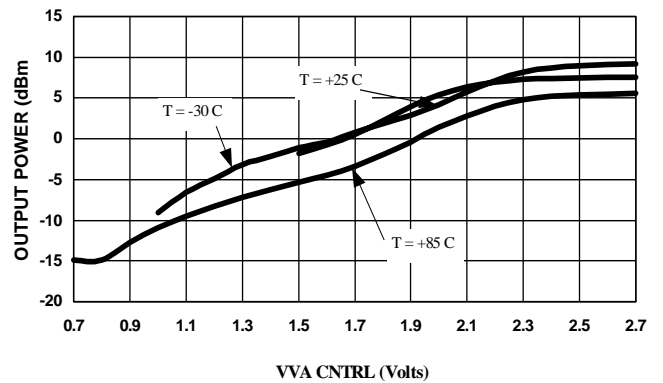

MIX_OUT to VGA_IN Isolation Over Temperature, LO=-5dBm, VBatt and VR5 = 3.0V

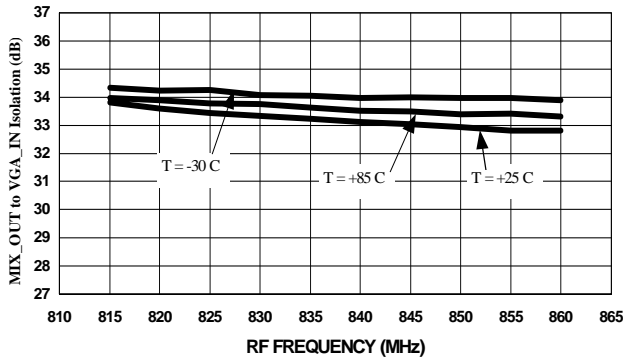

Specifications subject to change without notice.

V 2.0

- North America: Tel. (800) 366-2266, Fax (800) 618-8883
- Asia/Pacific: Tel.+81-44-844-8296, Fax +81-44-844-8298
- Europe: Tel. +44 (1344) 869 595, Fax+44 (1344) 300 020

Visit www.macom.com for additional data sheets and product information.



5 mm MLF - 20¹

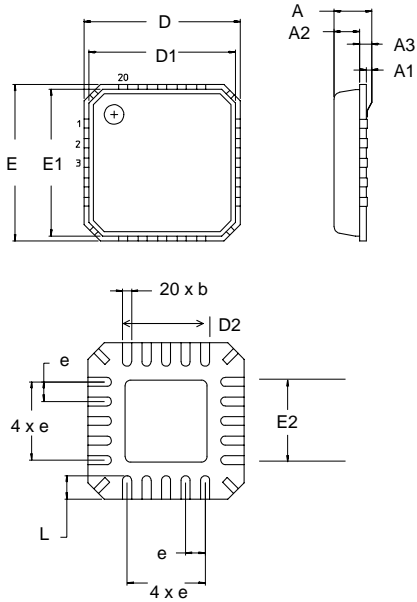

1. See JEDEC MO-220A VGGD- for additional dimensional and tolerance information

5 mm MLF - 20

Dim.	Measurement (mm)		
	Min.	Nom.	Max.
A	0.80	0.90	1.00
A1	0	0.02	0.05
A2	0	0.65	1.00
A3		0.25 ref.	
b	0.23	0.30	0.38
D		5.00 basic	
D1		4.75 basic	
D2	1.25	2.70	3.25
e		0.65 basic	
E		5.00 basic	
E1		4.75 basic	
E2	1.25	2.70	3.25
L	0.35	0.55	0.75

Specifications subject to change without notice.

V 2.0

■ North America: Tel. (800) 366-2266, Fax (800) 618-8883
 ■ Asia/Pacific: Tel.+81-44-844-8296, Fax +81-44-844-8298
 ■ Europe: Tel. +44 (1344) 869 595, Fax+44 (1344) 300 020

Visit www.macom.com for additional data sheets and product information.

tyco / Electronics

MACOM