

LOW VOLTAGE ADJUSTABLE SHUNT REFERENCE

- **LOW VOLTAGE OPERATION : 1.24 TO 6V**
- **2%, 1% AND 0.5% VOLTAGE PRECISION**
- **WIDE OPERATING RANGE CATHODE CURRENT : 60 μ A TO 30mA**
- **LOW OUTPUT IMPEDANCE : 0.2 Ω**
- **TYPICALLY STABLE FOR ANY CAPACITIVE LOADS**
- **ESD PROTECTION :**
2kV (Human Body Model)
200V (Machine Model)
- **100ppm/ $^{\circ}$ C TEMPERATURE COEFFICIENT**

DESCRIPTION

The TS431 is a low voltage three terminals programmable shunt Voltage Reference. The output voltage can be set to any value between V_{ref} (1.24V) and 6V with two external resistors. The TS431 is able to operate at a lower voltage (1.24V) and lower cathode current than the widespread TL431 and TL1431 shunt voltage reference.

When driving an optocoupler, the TS431 is particularly interesting to regulate 3.3V switching power supplies.

PIN CONNECTIONS (top view)

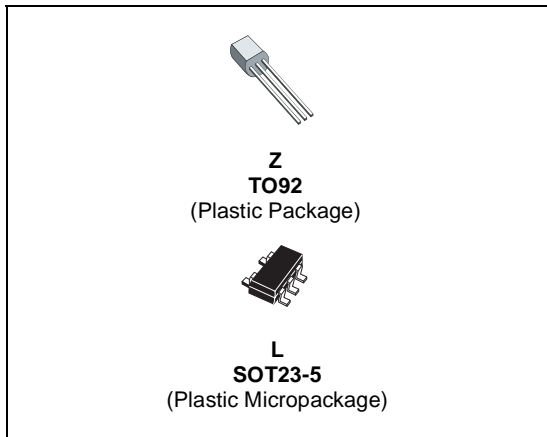
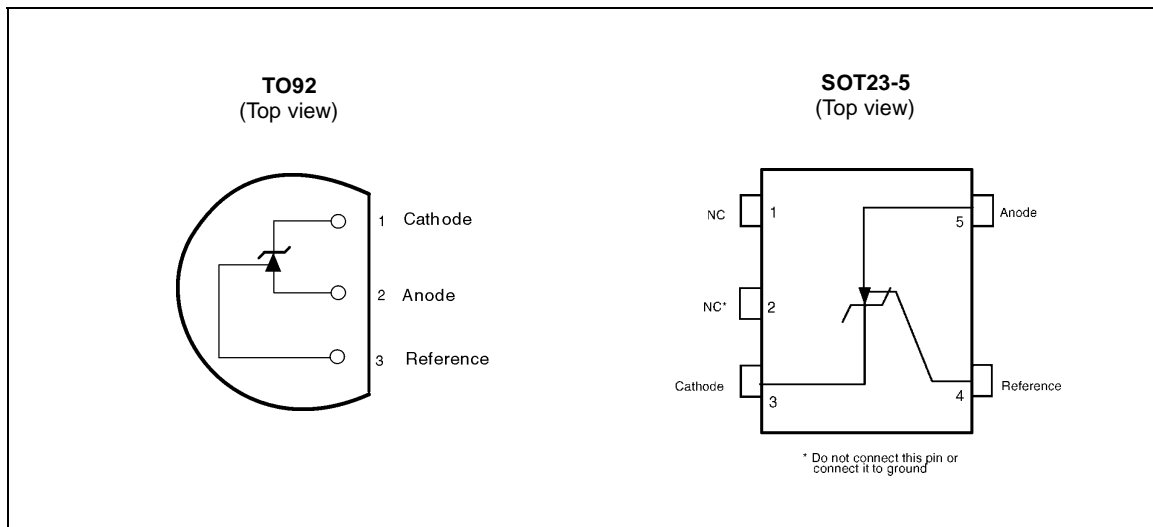

ORDER CODE

Part Number	Temperature Range	Package		SOT-23 Marking
		Z	L	
TS431I	-40 $^{\circ}$ C, +125 $^{\circ}$ C	•	•	L272
TS431AI		•	•	L271
TS431BI		•	•	L270

Z = T092 Plastic package - also available in Bulk (Z), Tape & Reel (ZT) and Ammo Pack (AP)

LT = Tiny Package (SOT23-5) - only available in Tape & Reel (LT)

TS431

ABSOLUTE MAXIMUM RATINGS

Symbol	Parameter	Value	Unit	
V_{KA}	Cathode to Anode Voltage	10	V	
I_k	Continuous Cathode Current Range	-20 to +40	mA	
I_{ref}	Reference Input Current Range	-0.05 to +3	mA	
P_d	Power Dissipation ¹⁾	TO92 package SOT23-5 package	625 500	mW
T_{std}	Storage Temperature Range	-65 to +150	°C	

1. $T_{junction}=150^{\circ}\text{C}$, $T_{amb}=25^{\circ}\text{C}$ with $R_{THj-a}=200^{\circ}\text{C/W}$ for TO92 package and $R_{THj-a}=250^{\circ}\text{C/W}$ for SOT23-5L package

OPERATING CONDITIONS

Symbol	Parameter	Value	Unit
V_{KA}	Cathode to Anode Voltage	1.24 to 6	V
I_k	Cathode Current	0.06 to 30	mA
T_{oper}	Operating Free Air Temperature Range	-40 to +125	°C

ELECTRICAL CHARACTERISTICS

$T_{amb} = 25^{\circ}\text{C}$ (unless otherwise specified)

Symbol	Parameter	Test Condition	Min.	Typ.	Max.	Unit
V_{ref}	Output Voltage $V_{KA} = V_{ref}$ @ $I_k = 100\mu\text{A}$	TS431 TS431A TS431B	1.215 1.228 1.234	1.240	1.265 1.252 1.246	V
ΔV_{ref}	Output Voltage Change ^{1) 2)} $I_k = 100\mu\text{A}$, $V_{KA} = V_{ref}$	$0 < T_{amb} < +70^{\circ}\text{C}$ $-40 < T_{amb} < +85^{\circ}\text{C}$ $-40 < T_{amb} < +105^{\circ}\text{C}$ $-40 < T_{amb} < +125^{\circ}\text{C}$			9 16 18 21	mV
$\frac{ \Delta V_{ref} }{ \Delta V_{ka} }$	Ratio of Change in Reference Input Voltage to Change in Cathode to Anode Voltage	$I_k = 10\text{mA}$ $V_{KA} = 6\text{V to } V_{ref}$		1.8	2.7	mV/V
I_{ref}	Reference Input Current	$I_k = 10\text{mA}$		70	160	nA
ΔI_{ref}	Reference Input Current Deviation Over Temperature Range	$I_k=10\text{mA}$ $R_1=10\text{k}\Omega$ $R_2=\infty$ $-40 < T_{amb} < +85^{\circ}\text{C}$ $-40 < T_{amb} < +125^{\circ}\text{C}$		70 90	160 240	nA
I_{min}	Minimum Cathode Current for Regulation	$V_{KA} = V_{ref}$		40	60	μA
I_{off}	Off-State Cathode Current	$V_{KA} = 6\text{V}$, $V_{ref} = 0$		0.001	0.1	μA
R_{KA}	Static Impedance	$V_{KA} = V_{ref}$, $I_k = 0.1$ to 15mA		0.2	0.4	Ω

1. Limits are 100% production tested at 25°C. Limits over temperature are guaranteed through correlation and by design.

2. ΔV_{ref} is defined as the difference between the maximum and minimum values obtained over the full temperature range.
 $\Delta V_{ref} = V_{ref\ max.} - V_{ref\ min.}$

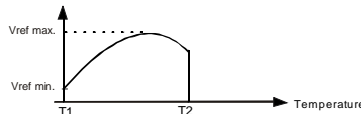

Reference voltage vs temperature

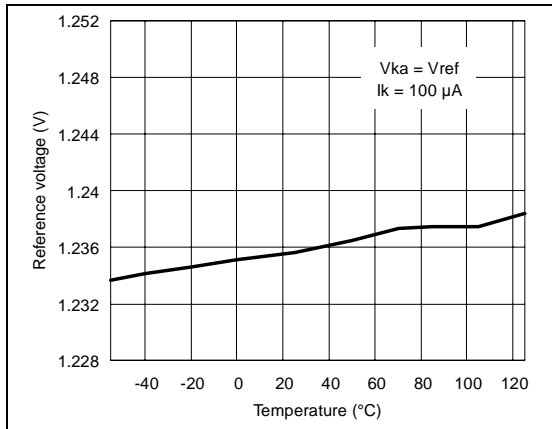

Test circuit for $V_{ka} = V_{ref}$

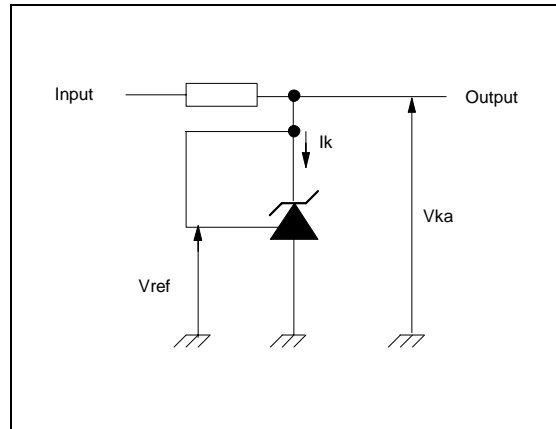

Cathode voltage vs cathode current

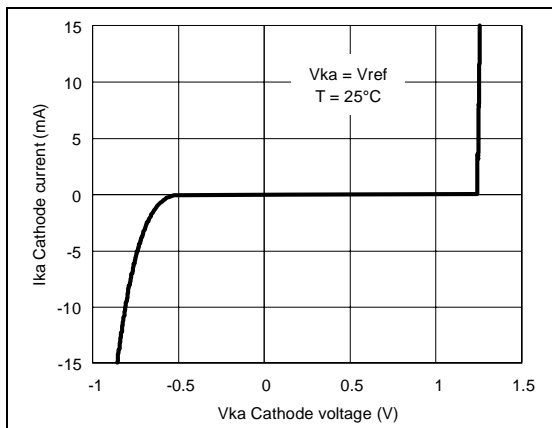

Cathode voltage vs cathode current

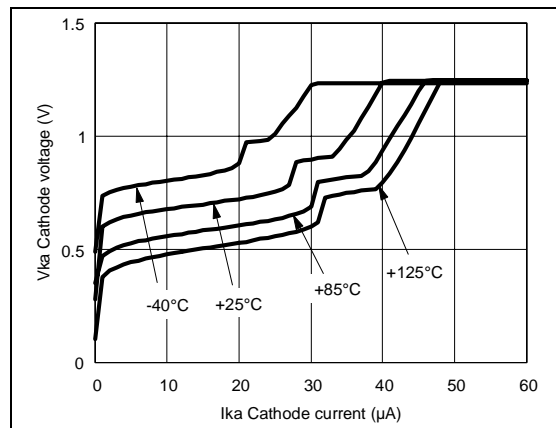

Reference input current vs temperature

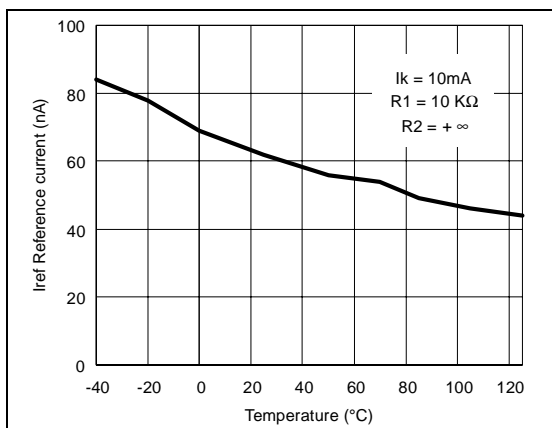

Static impedance vs temperature

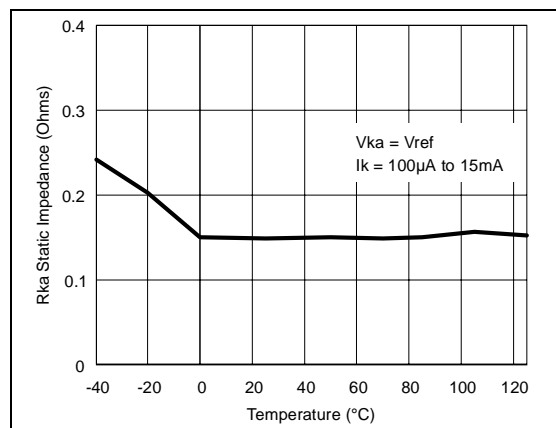

Off-State current vs temperature

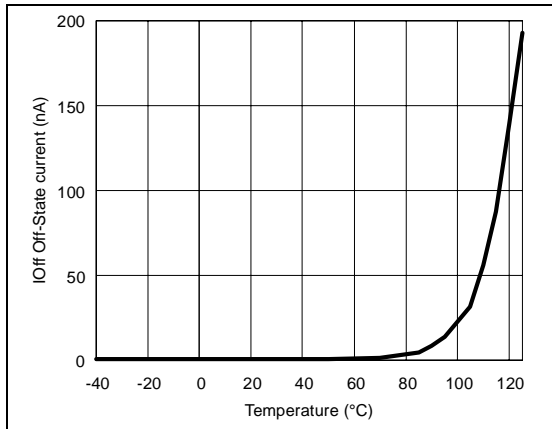

Test circuit for Off-State current measurement

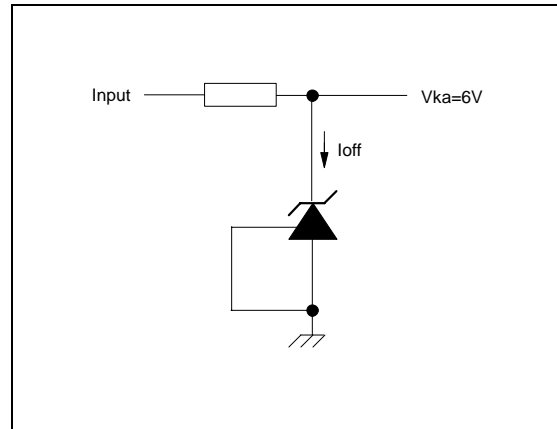

Ratio of change in reference input voltage to change in Vka voltage vs temperature

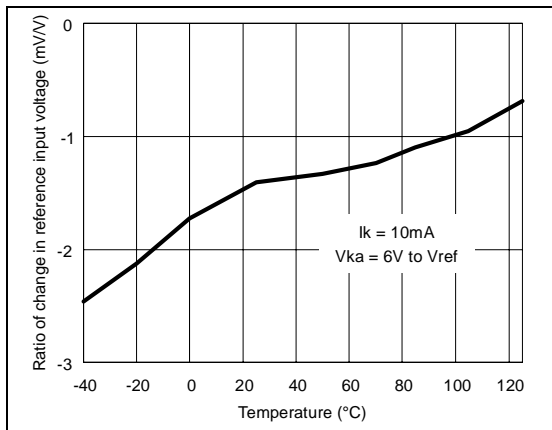

Test circuit for Vka > Vref

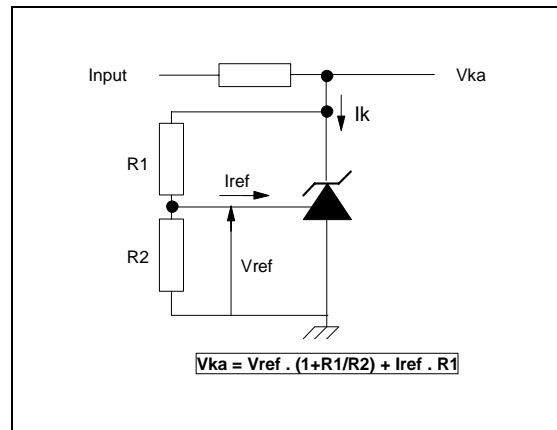

Phase and Gain vs frequency

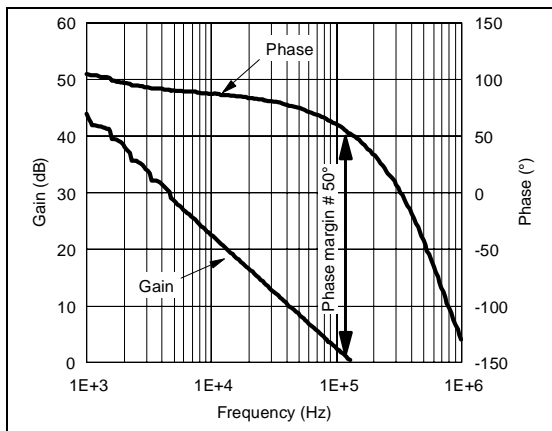

Test circuit for phase and gain measurement

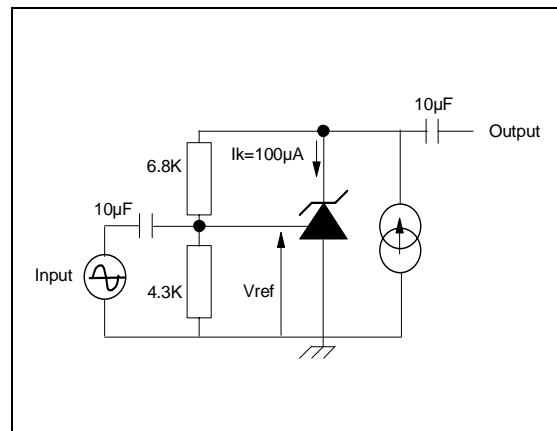

Pulse response at $I_k=100\mu\text{A}$

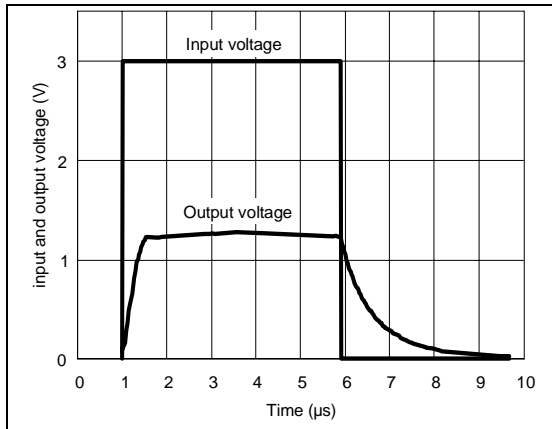

Test circuit for pulse response at $I_k = 100\mu\text{A}$

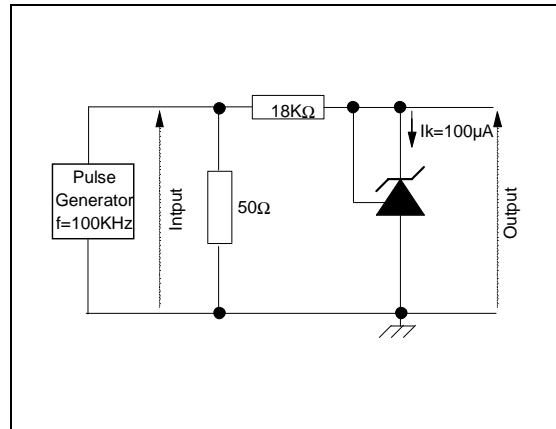

Pulse response at $I_k = 1\text{mA}$

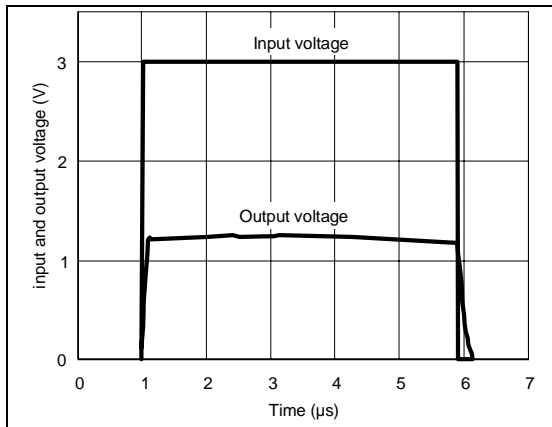

Test circuit for pulse response at $I_k = 1\text{mA}$

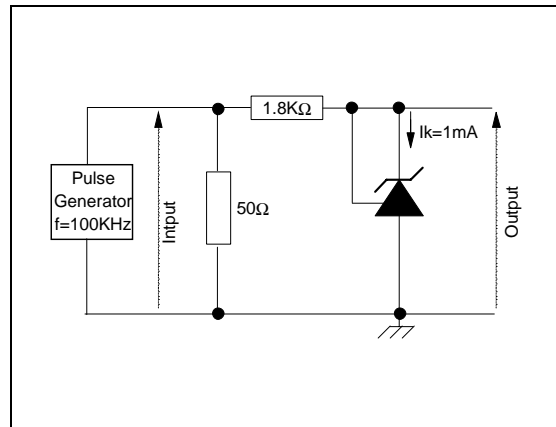

Equivalent input noise vs frequency

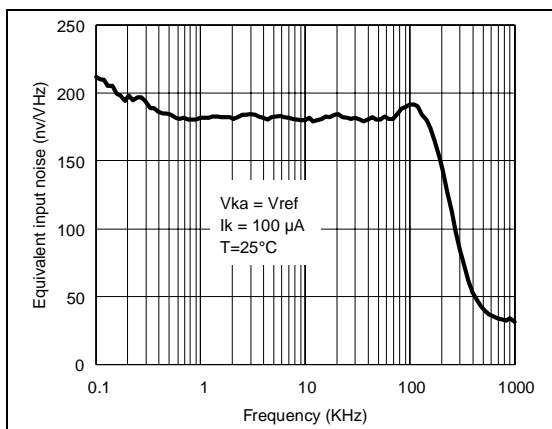

PACKAGE MECHANICAL DATA

3 PINS - PLASTIC PACKAGE TO92 (TAPE & REEL)

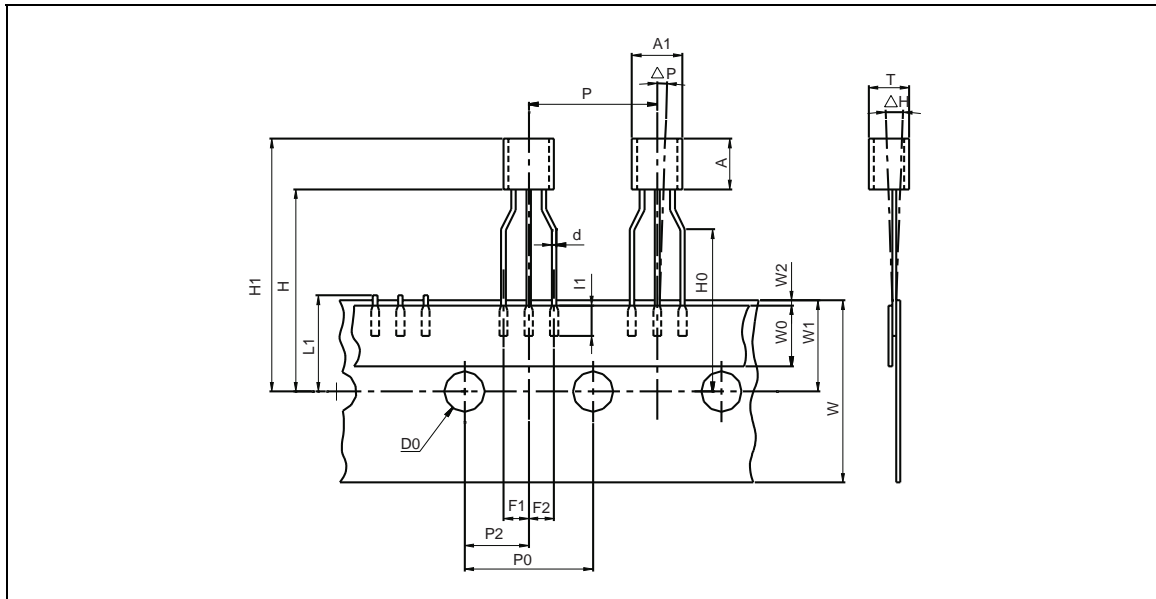

Dim.	Millimeters			Inches		
	Min	Typ.	Max.	Min.	Typ.	Max.
AL			5.0			0.197
A			5.0			0.197
T			4.0			0.157
d		0.45			0.018	
l1	2.5			0.098		
P	11.7	12.7	13.7	0.461	0.500	0.539
PO	12.4	12.7	13	0.488	0.500	0.512
P2	5.95	6.35	6.75	0.234	0.250	0.266
F1/F2	2.4	2.5	2.8	0.094	0.098	0.110
Δh	-1	0	1	-0.039	0	0.039
ΔP	-1	0	1	-0.039	0	0.039
W	17.5	18.0	19.0	0.689	0.709	0.748
W0	5.7	6	6.3	0.224	0.236	0.248
W1	8.5	9	9.75	0.335	0.354	0.384
W2			0.5			0.020
H			20			0.787
H0	15.5	16	16.5	0.610	0.630	0.650
H1			25			0.984
DO	3.8	4.0	4.2	0.150	0.157	0.165
L1			11			0.433

PACKAGE MECHANICAL DATA
3 PINS - PLASTIC PACKAGE TO92 (TAPE AMMO PACK)

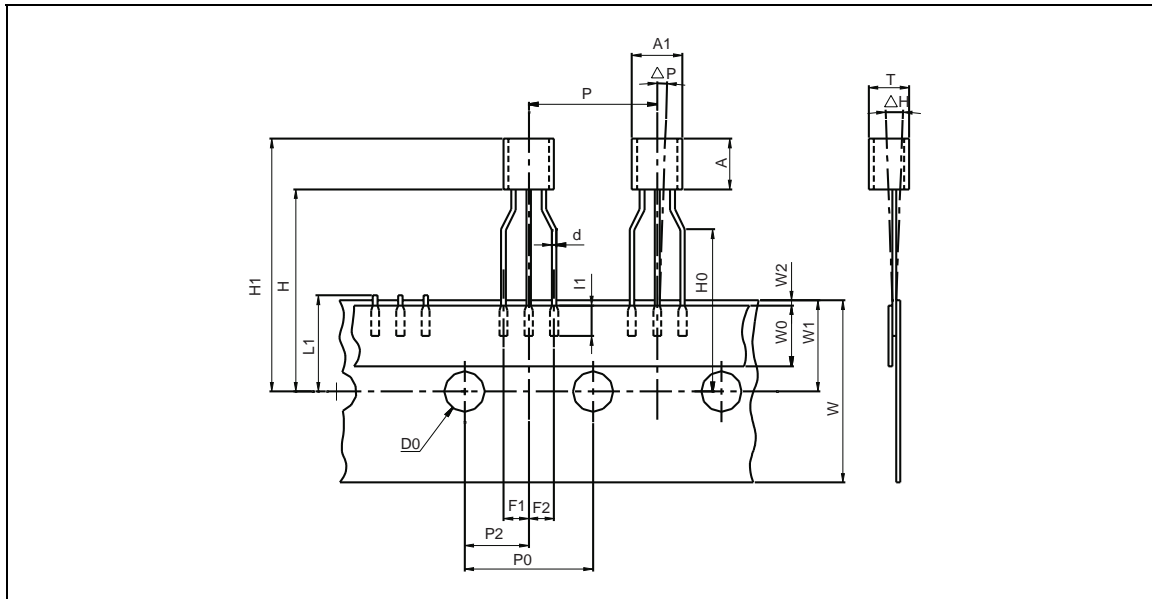

Dim.	Millimeters			Inches		
	Min	Typ.	Max.	Min.	Typ.	Max.
AL			5.0			0.197
A			5.0			0.197
T			4.0			0.157
d		0.45			0.018	
I1	2.5			0.098		
P	11.7	12.7	13.7	0.461	0.500	0.539
PO	12.4	12.7	13	0.488	0.500	0.512
P2	5.95	6.35	6.75	0.234	0.250	0.266
F1/F2	2.4	2.5	2.8	0.094	0.098	0.110
Δh	-1	0	1	-0.039	0	0.039
ΔP	-1	0	1	-0.039	0	0.039
W	17.5	18.0	19.0	0.689	0.709	0.748
W0	5.7	6	6.3	0.224	0.236	0.248
W1	8.5	9	9.75	0.335	0.354	0.384
W2			0.5			0.020
H			20			0.787
H0	15.5	16	16.5	0.610	0.630	0.650
H1			25			0.984
DO	3.8	4.0	4.2	0.150	0.157	0.165
L1			11			0.433

PACKAGE MECHANICAL DATA
 3 PINS - PLASTIC PACKAGE TO92 (BULK)

TO-92 MECHANICA DATA

DIM.	mm.			mils		
	MIN.	TYP.	MAX.	MIN.	TYP.	MAX.
A	4.32		4.95	170.1		194.9
b	0.36		0.51	14.2		20.1
D	4.45		4.95	175.2		194.9
E	3.30		3.94	129.9		155.1
e	2.41		2.67	94.9		105.1
e1	1.14		1.40	44.9		55.1
L	12.7		15.49	500.0		609.8
R	2.16		2.41	85.0		94.9
S1	0.92		1.52	36.2		59.8
W	0.41		0.56	16.1		22.0

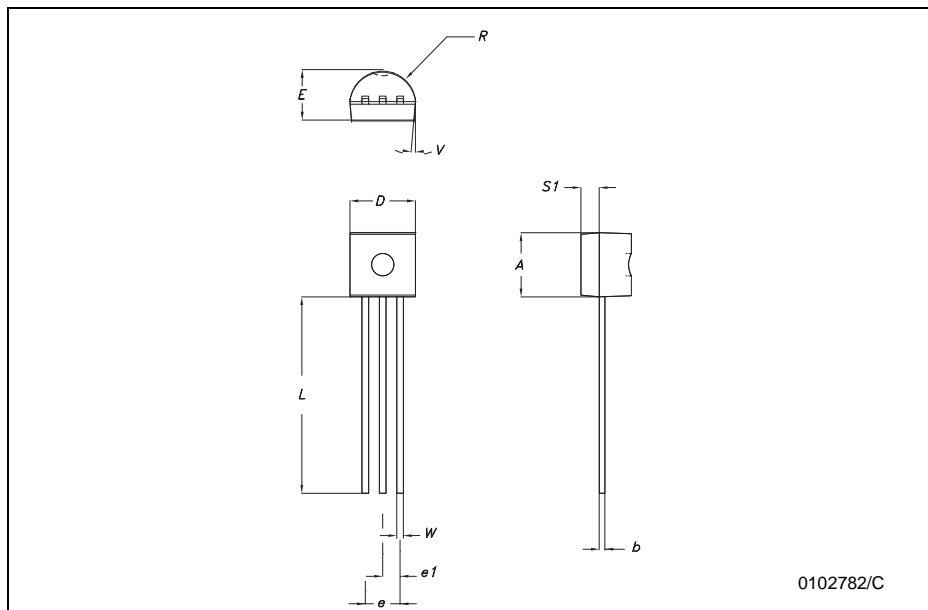

PACKAGE MECHANICAL DATA

SOT23-5L MECHANICAL DATA						
DIM.	mm.			mils		
	MIN.	TYP.	MAX.	MIN.	TYP.	MAX.
A	0.90		1.45	35.4		57.1
A1	0.00		0.15	0.0		5.9
A2	0.90		1.30	35.4		51.2
b	0.35		0.50	13.7		19.7
C	0.09		0.20	3.5		7.8
D	2.80		3.00	110.2		118.1
E	2.60		3.00	102.3		118.1
E1	1.50		1.75	59.0		68.8
e		0.95			37.4	
e1		1.9			74.8	
L	0.35		0.55	13.7		21.6

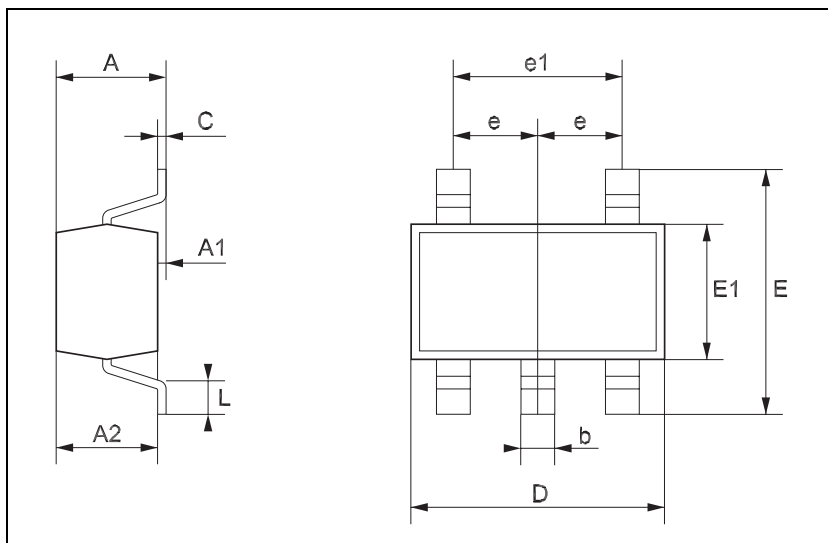

Information furnished is believed to be accurate and reliable. However, STMicroelectronics assumes no responsibility for the consequences of use of such information nor for any infringement of patents or other rights of third parties which may result from its use. No license is granted by implication or otherwise under any patent or patent rights of STMicroelectronics. Specifications mentioned in this publication are subject to change without notice. This publication supersedes and replaces all information previously supplied. STMicroelectronics products are not authorized for use as critical components in life support devices or systems without express written approval of STMicroelectronics.

The ST logo is a registered trademark of STMicroelectronics
All other names are the property of their respective owners.

© 2003 STMicroelectronics - All Rights Reserved

STMicroelectronics GROUP OF COMPANIES

Australia - Belgium - Brazil - Canada - China - Czech Republic - Finland - France - Germany
Hong Kong - India - Israel - Italy - Japan - Malaysia - Malta - Morocco - Singapore - Spain
Sweden - Switzerland - United Kingdom - United States
<http://www.st.com>

