

DBL 1018

FM IF SYSTEM

The DBL1018 has versatile muting characteristics and allows receiver designers to realize the muting performance according to their design concept.

FUNCTIONS

- FM IF Amplifier/Limiter
- Quadrature Detector
- AFC Clamp
- AGC Drive
- AF Mute Amplifier
- Signal Meter Drive
- DC Level Detector

FEATURES

- Adjustable muting sensitivity
- Soft muting function
- Variable maximum muting attenuation(6dB~40dB)
- Variable muting slope with respect to input signal level
- High limiting sensitivity with muting off
- Good S/N ratio
- Clamped AFC output
- Delayed AGC output for front end circuit
- Recommended supply voltage: $V_{CC} = 8V$
- Operating supply voltage range: $V_{CC} = 7.5V \sim 16V$
- Low distortion
- Good AMR

APPLICATIONS

- FM car stereo receiver

MAXIMUM RATINGS ($T_a=25^\circ C$)

Characteristic	Symbol	Rating	Unit
Supply Voltage	V_{CC}	16	V
Supply Current	I_{CC}	40	mA
Power Dissipation	P_D	640	mW
Operation Temperature	T_{opr}	-20 ~ +70	$^\circ C$
Storage Temperature	T_{stg}	-40 ~ +125	$^\circ C$

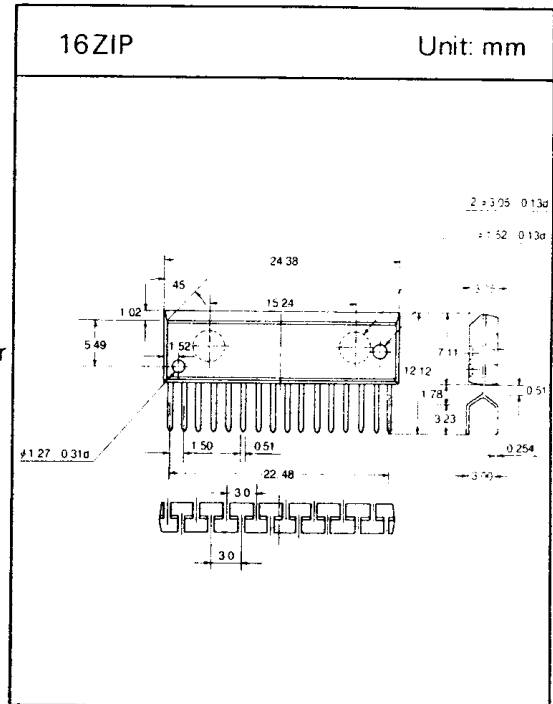

DBL 1018

FM IF SYSTEM

The DBL1018 has versatile muting characteristics and allows receiver designers to realize the muting performance according to their design concept.

FUNCTIONS

- FM IF Amplifier/Limiter
- Quadrature Detector
- AFC Clamp
- AGC Drive
- AF Mute Amplifier
- Signal Meter Drive
- DC Level Detector

FEATURES

- Adjustable muting sensitivity
- Soft muting function
- Variable maximum muting attenuation(6dB~40dB)
- Variable muting slope with respect to input signal level
- High limiting sensitivity with muting off
- Good S/N ratio
- Clamped AFC output
- Delayed AGC output for front end circuit
- Recommended supply voltage: $V_{CC} = 8V$
- Operating supply voltage range: $V_{CC} = 7.5V \sim 16V$
- Low distortion
- Good AMR

APPLICATIONS

- FM car stereo receiver

MAXIMUM RATINGS ($T_a=25^\circ C$)

Characteristic	Symbol	Rating	Unit
Supply Voltage	V_{CC}	16	V
Supply Current	I_{CC}	40	mA
Power Dissipation	P_D	640	mW
Operation Temperature	T_{opr}	-20 ~ +70	$^\circ C$
Storage Temperature	T_{stg}	-40 ~ +125	$^\circ C$

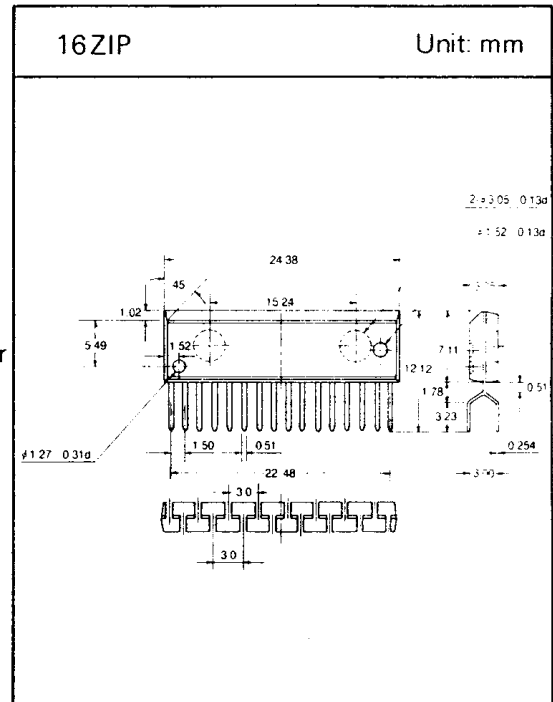

□ INFORMATION ON MUTING CHARACTERISTIC (continued)

The inverted output of the signal meter drive output is obtained as shown Fig. 3.

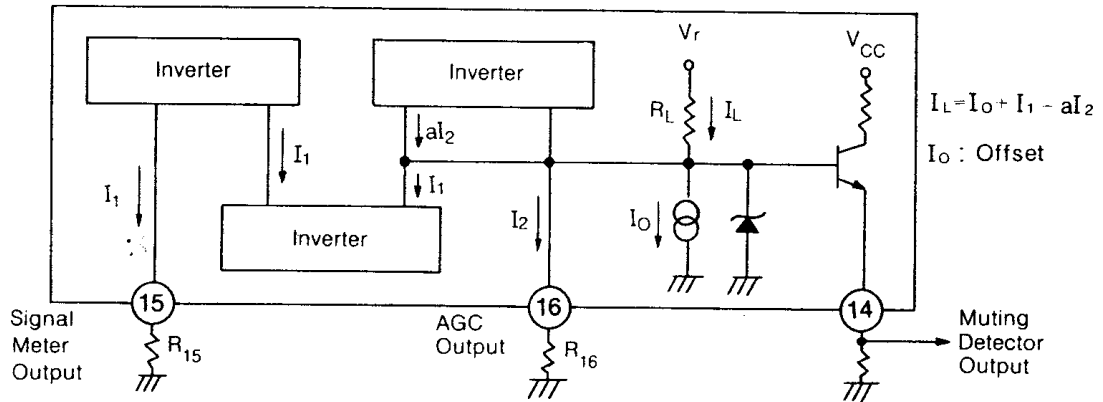

Fig. 3

By Fig. 3, V_{14} is given by $V_{14} = V_r - (I_O + I_1 - aI_2)R_L - V_{BE}$. Conditions are $V_r = 4.9\text{v}$, $I_O \cong 0.2\text{mA}$, $a \cong 2$, $R_L = 22\text{K}\Omega$, $V_{BE} = 0.7\text{V}$, $I_1 = V_{15}/R_{15}$, $I_2 = V_{16}/R_{16}$, where V_{16} is a constant equal to 4.1V (Typ.) for medium or lower signal input levels where the muting drive output is required. Since the V_{15} increases proportionally to the increase of the input signal level, I_1 will also increase, and the V_{14} will decrease. Thus the required muting drive output can be obtained by selecting proper values of R_{15} and R_{16} . Increasing R_{15} makes the slope of the curve for the muting drive output vs. antenna signal input decrease, or decreasing the R_{15} increase the slope of the curve.

Furthermore, varying the value of a resistor connected between the pin 14 and pin 16 changes the value of the muting control current required to obtain the same muting drive output, accordingly a slope of curve for muting attenuation vs. antenna signal input level is also changed. Fig. 4 shows these characteristics investigated by using an actual receiver.

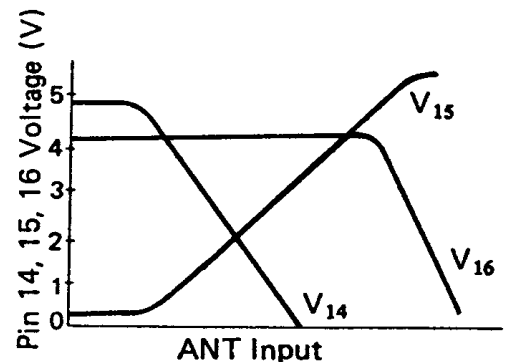
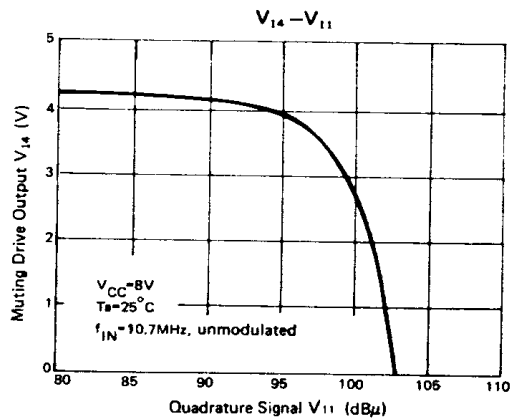
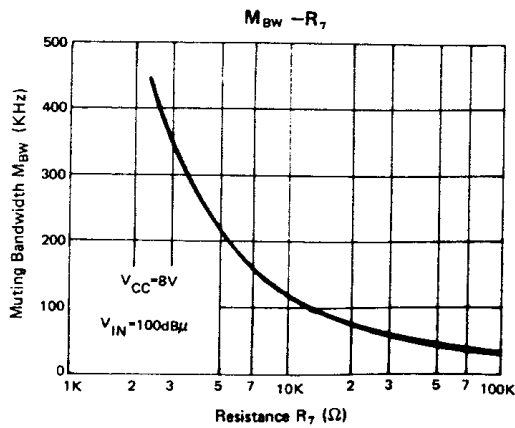
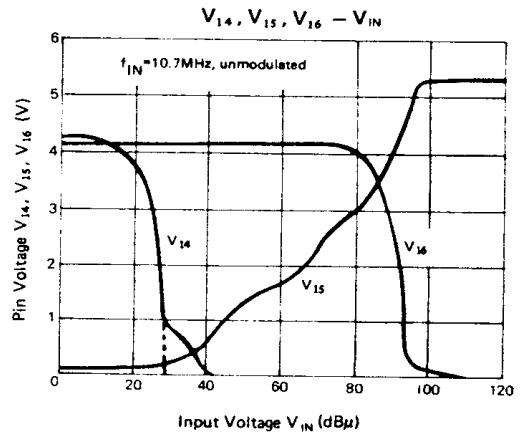
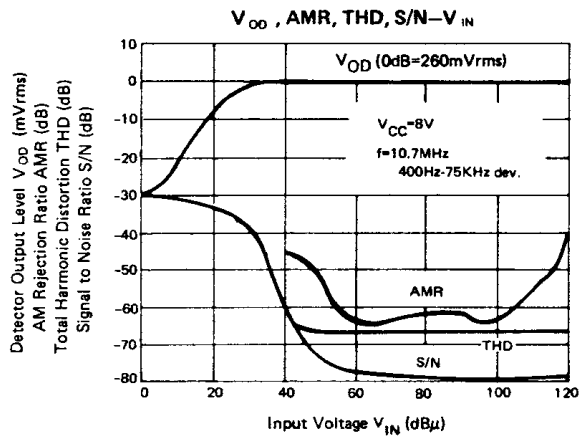
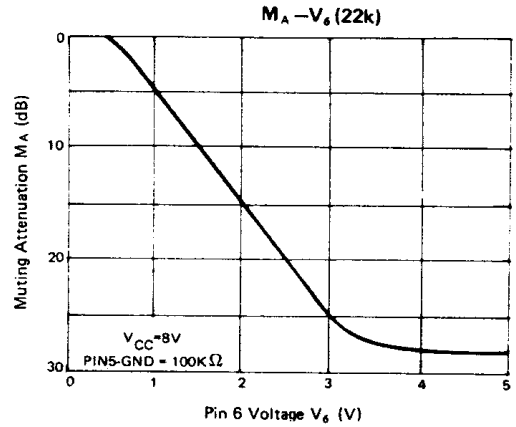
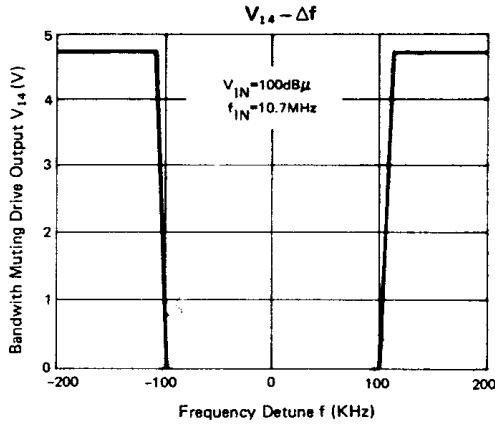

Fig. 4

The method to adjust the muting circuit is to set the signal input level required to actuate the muting circuit with the R_{16} , to adjust the slope of the curve for the muting attenuations vs. antenna signal input with the R_{15} and to adjust the maximum muting attenuation determined by setting the noise level at no signal. The slope of the curve for the muting attenuation vs. antenna signal input level can also be adjusted by the resistor connected between the pin 14 and the pin 6. However, if the resistor is too high, the muting control current does not flow into pin 6 over than $120\mu\text{A}$ even though the maximum muting drive output (V_{14}) is applied, namely the muting attenuation doesn't reach its maximum value. A recommended value of the resistor between the pin 14 and the pin 6 is about $22\text{K}\Omega$.

DBL 1018

TYPICAL PERFORMANCE CHARACTERISTICS



□ TYPICAL PERFORMANCE CHARACTERISTICS (continued)

