

VIDEO AMPLIFIER

■ GENERAL DESCRIPTION

The NJM592 is a video amplifier of differential input and differential output.

The NJM592 is suitable for a preamplifier of memory equipment and video and pulse signal amplifier.

■ FEATURES

- Wide Frequency Range (40MHz, 90MHz typ.)
- Differential Input, Differential Output.
- With Gain Select Terminal
- Package Outline DIP 8 / 14, DMP8/14, SSOP 8/14 .
- Bipolar Technology

■ PACKAGE OUTLINE

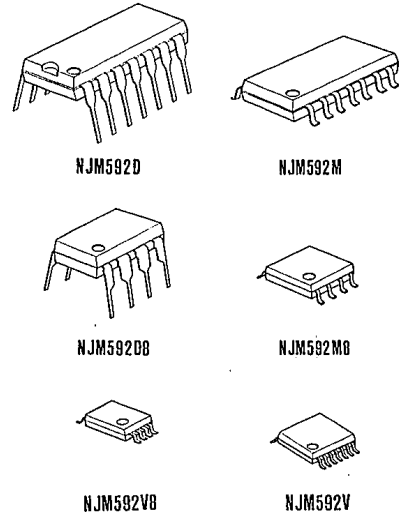

■ PIN CONFIGURATION

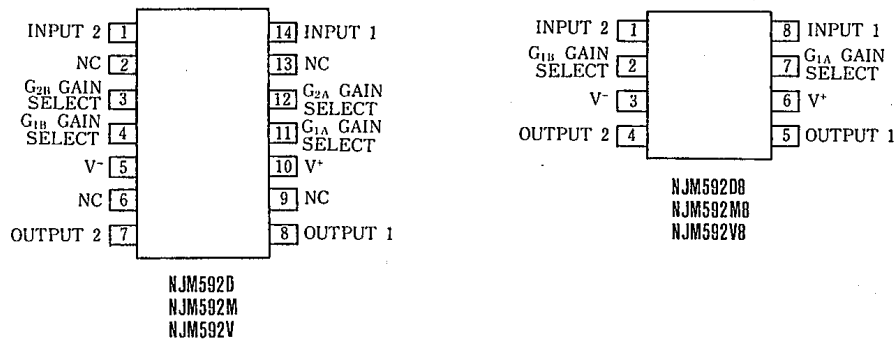

■ EQUIVALENT CIRCUIT

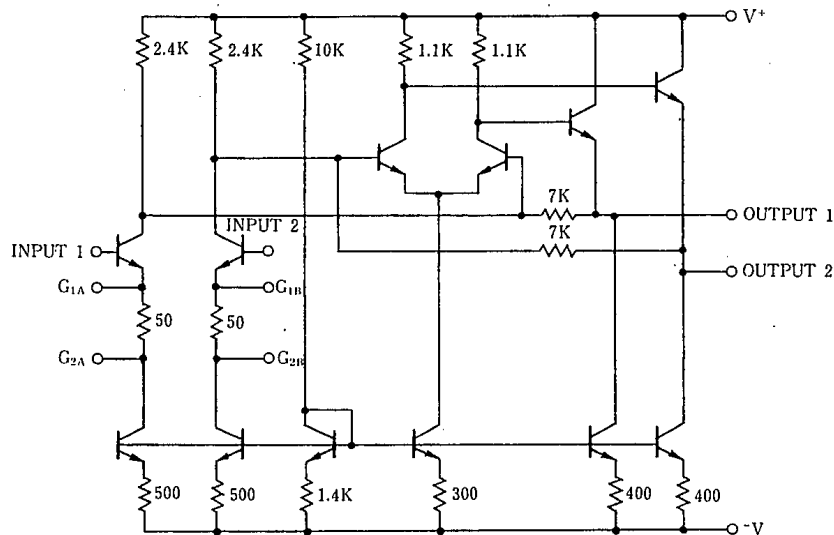

■ ABSOLUTE MAXIMUM RATINGS

(Ta=25°C)

PARAMETER	SYMBOL	RATINGS	UNIT
Supply Voltage	V/V ⁻	±8	V
Differential Input Voltage	V _{DIFF}	±5	V
Common Mode Input Voltage	V _{CM}	±6	V
Output Current	I _o	10	mA
Operating Temperature Range	T _{opr}	-40 ~ +85	°C
Storage Temperature Range	T _{stg}	-40 ~ +125	°C
Power Dissipation	P _d	(DIP14) 500	mW
		(DMP14) 300	mW
		(SSOP14) 300	mW
		(DIP8) 500	mW
		(DMP8) 300	mW
		(SSOP8) 250	mW

■ ELECTRICAL CHARACTERISTICS

(Ta=25°C, V⁺=±6V, V_{CM}=0)

PARAMETER	TEST CONDITION	MIN.	TYP.	MAX.	UNIT
Differential Voltage Gain1 (note 1) Differential Voltage Gain2 (note 2, 4)	R _L =2kΩ, V _{OUT} =3V _{P-P}	250 80	400 100	600 120	V/V
Bandwidth Gain1 (note 1) Bandwidth Gain2 (note 2,4)		— —	40 90	— —	MHz
Rise Time Gain1 (note 1) Rise Time Gain2 (note 2,4)	V _{OUT} =1V _{P-P}	— —	10.5 4.5	— —	ns
Propagation Delay 1 Gain1 (note 1) Propagation Delay 2 Gain2 (note 2,4)	V _{OUT} =1V _{P-P}	— —	7.5 6.0	— —	ns
Input Resistance Gain1 (note 1) Input Resistance Gain2 (note 2,4)		— —	4.0 30	— —	kΩ
Input Capacitance Gain2 (note 2,4)		—	2.0	—	pF
Input Offset Current		—	0.4	5.0	μA
Input Bias Current		—	9.0	30	μA
Input Noise Voltage	BW=1kHz~10MHz	—	12	—	μVrms
Input Voltage Range		—	—	±1.0	V
Common Mode Rejection Ratio Gain2 (note 4) Common Mode Rejection Ratio Gain2 (note 4)	V _{CM} =±1V, f<100kHz V _{CM} =±1V, f=5MHz	60 —	86 60	— —	dB
Supply Voltage Rejection Ratio Gain2 (note 4)	ΔV ⁺ /V ⁺ = ±0.5V	50	70	—	dB
Output Offset Voltage Gain1 (note 1) Output Offset Voltage Gain2 (note 2,4) Output Offset Voltage Gain3 (note,3)	R _L =∞ R _L =∞ R _L =∞	— — —	— — 0.35	1.5 1.5 0.75	V
Output Common Mode Voltage	R _L =∞	2.4	2.9	3.4	V
Output Voltage Swing	R _L =2KΩ	3.0	4.0	—	V
Output Resistance		—	20	—	Ω
Operating Current	R _L =∞	—	18	24	mA

(note 1): Gain select pins G_{1A} and G_{1B} connected together. (Gain1)

(note 2): Gain select pins G_{2A} and G_{2B} connected together. (Gain2)

(note 3): All gain select pins open.

(note 4): Apply to only 14 pin package.

5

TYPICAL CHARACTERISTICS

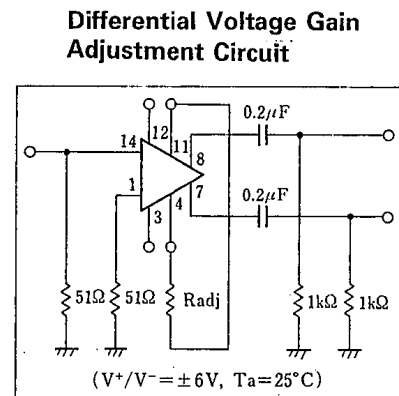
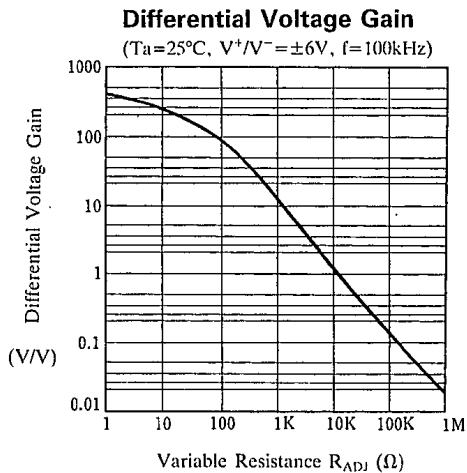
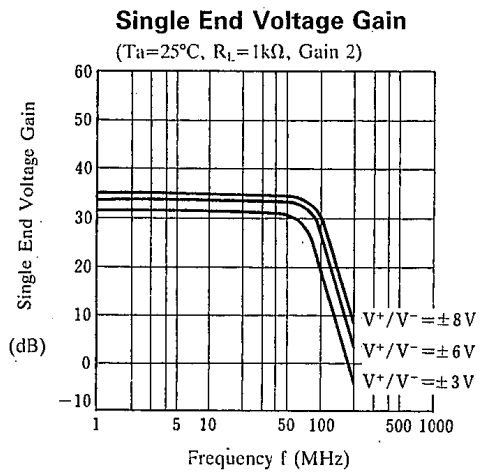
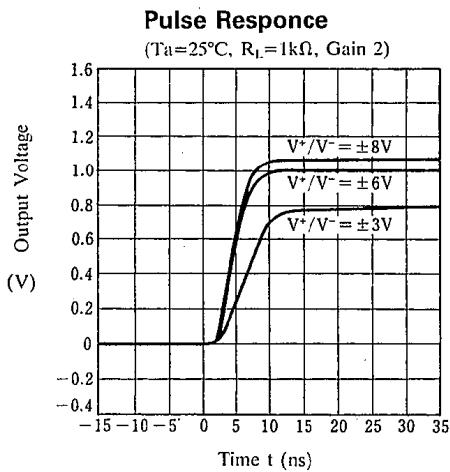
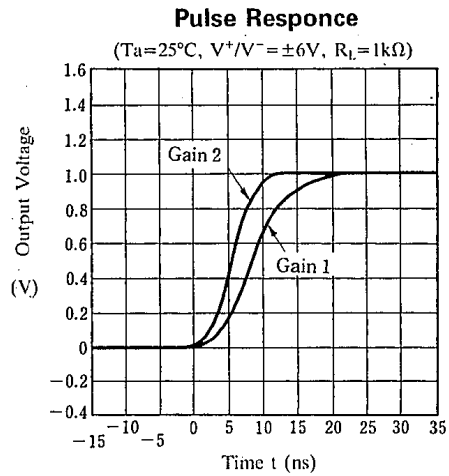
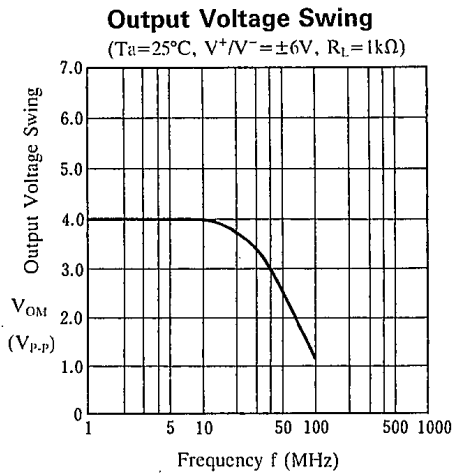

5

■ TYPICAL CHARACTERISTICS

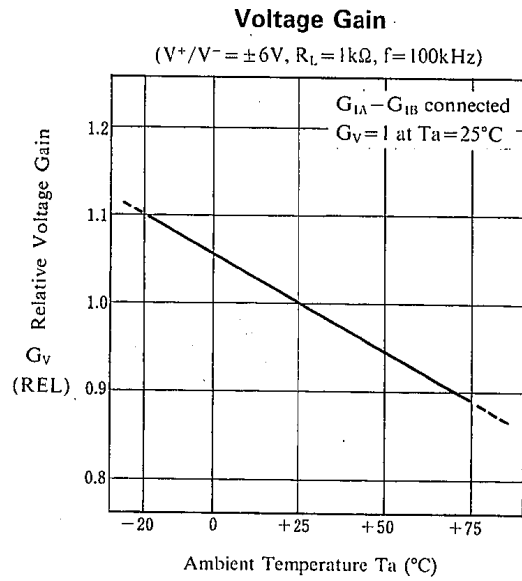
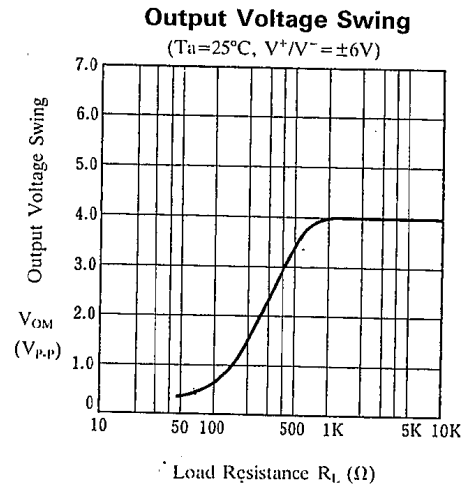
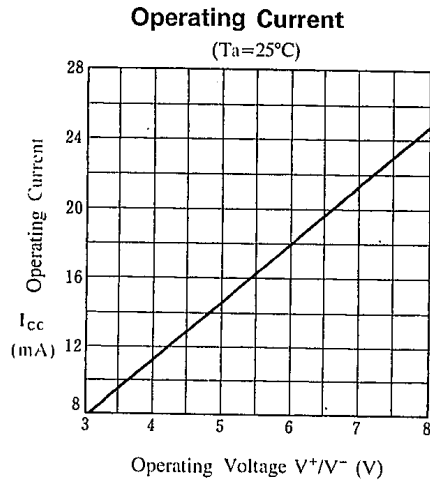

TEST CIRCUIT

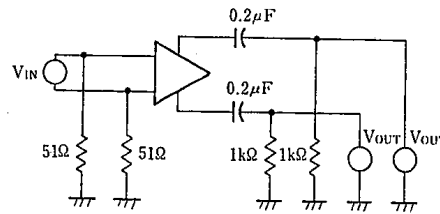
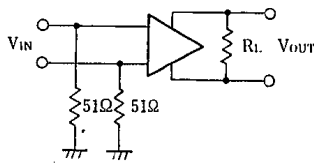

TYPICAL APPLICATION

Basic circuit

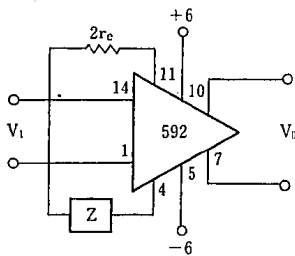

$$\frac{V_o(s)}{V_i(s)} \approx \frac{1.4 \times 10^4}{Z(s) + 2r_e}$$

$$\approx \frac{1.4 \times 10^4}{Z(s) + 32}$$

Filter Network

Z NETWORK	FILTER TYPE	$\frac{V_o(s)}{V_i(s)}$ TRANSFER FUNCTION
	LOW PASS	$\frac{1.0 \times 10^4}{L} \left[\frac{1}{s + R/L} \right]$
	HIGH PASS	$\frac{1.4 \times 10^4}{R} \left[\frac{s}{s + 1/RC} \right]$
	BAND PASS	$\frac{1.4 \times 10^4}{L} \left[\frac{s}{s^2 + R/L s + 1/LC} \right]$
	BAND REJECT	$\frac{1.4 \times 10^4}{R} \left[\frac{s^2 + 1/LC}{s^2 + 1/LC + s/RC} \right]$

(note): R includes $2 r_e$ ($\approx 32\Omega$)

5

Disk/Tape Phase Modulated Readback Systems

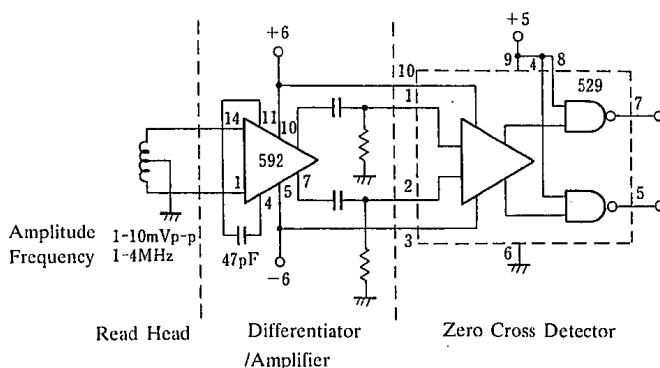

Differentiation with High Common Mode Noise Rejection

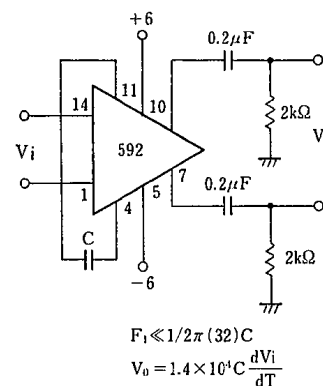

NJM592

MEMO

[CAUTION]

The specifications on this databook are only given for information, without any guarantee as regards either mistakes or omissions. The application circuits in this databook are described only to show representative usages of the product and not intended for the guarantee or permission of any right including the industrial rights.

New Japan Radio Co., Ltd.