

Single-Phase Single In-Line Bridge Rectifier

Reverse Voltage
200 and 800V
Forward Current 4.0A

Case Style GSIB-3G

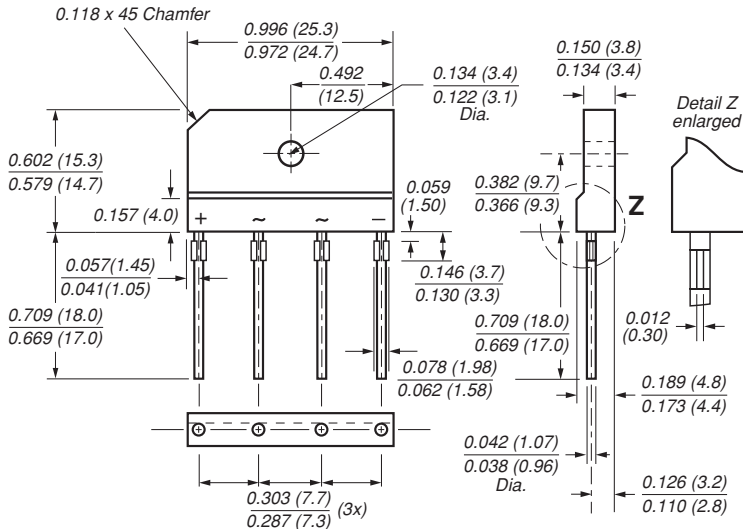

Dimensions in inches and (millimeters)
Use suffix "N" for no stand-off

Features

- Plastic package has Underwriters Laboratory Flammability Classification 94V-0
- High case dielectric strength of 1500 VRMS
- Ideal for printed circuit boards
- Glass passivated chip junction
- High surge current capability

Mechanical Data

Case: Molded plastic body over passivated junctions
Terminals: Plated leads solderable per MIL-STD-750, Method 2026
 High temperature soldering guaranteed:
 260°C/10 seconds, 0.375" (9.5mm) lead length, 5lbs. (2.3kg) tension
Mounting Position: Any ⁽³⁾
Mounting Torque: 5 in-lbs max.
Weight: 0.15 oz., 4.0 g

Maximum Ratings & Thermal Characteristics Ratings at 25°C ambient temperature unless otherwise specified.

Parameter	Symbol	GSIB420	GSIB440	GSIB460	GSIB480	Unit
Maximum repetitive peak reverse voltage	V _{RRM}	200	400	600	800	V
Maximum RMS voltage	V _{RMS}	140	280	420	560	V
Maximum DC blocking voltage	V _{DC}	200	400	600	800	V
Maximum average forward rectified output current at T _C = 100°C T _A = 25°C	I _{F(AV)}	4.0 ⁽¹⁾ 2.3 ⁽²⁾				A
Peak forward surge current single sine-wave superimposed on rated load (JEDEC Method)	I _{FSM}	130				A
Rating for fusing (t<8.3ms)	I ² t	60				A ² sec
Maximum thermal resistance per leg	R _{θJA} R _{θJC}	26 ⁽²⁾ 5 ⁽¹⁾				°C/W
Operating junction and storage temperature range	T _J , T _{STG}	-55 to +150				°C

Electrical Characteristics Ratings at 25°C ambient temperature unless otherwise specified.

Parameter	Symbol	GSIB420	GSIB440	GSIB460	GSIB480	Unit
Maximum instantaneous forward voltage drop per leg at 2.0A	V _F	0.95				V
Maximum DC reverse current at rated DC blocking voltage per leg T _A = 25°C T _A = 125°C	I _R	10 250				μA

Notes: (1) Unit case mounted on Al plate heatsink.
 (2) Units mounted on P.C.B. with 0.5 x 0.5" (12 x 12mm) copper pads and 0.375" (9.5mm) lead length
 (3) Recommended mounting position is to bolt down on heatsink with silicone thermal compound for maximum heat transfer with #6 screw

Ratings and Characteristic Curves ($T_A = 25^\circ\text{C}$ unless otherwise noted)

Fig. 1 – Derating Curve Output Rectified Current

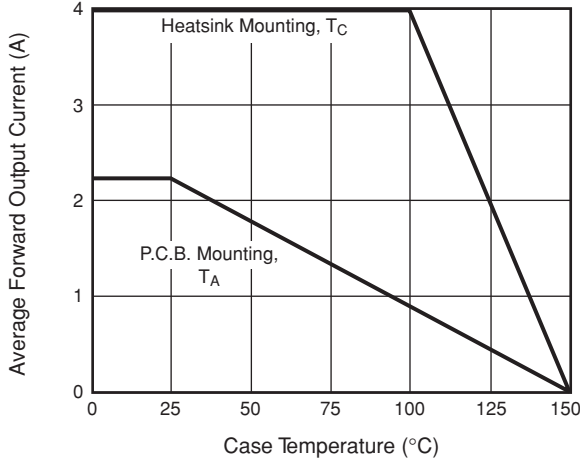

Fig. 2 – Maximum Non-Repetitive Peak Forward Surge Current Per Leg

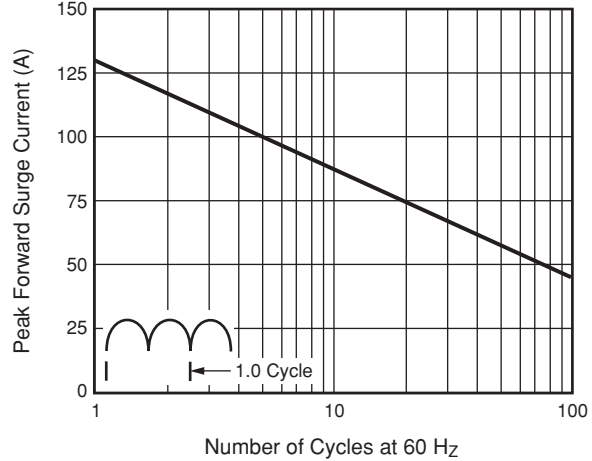

Fig. 3 – Typical Instantaneous Forward Characteristics Per Leg

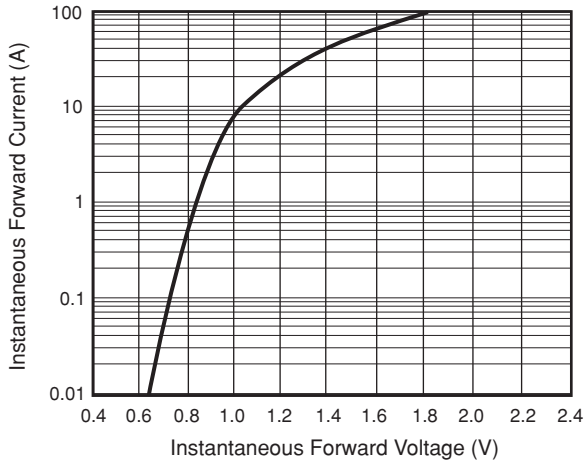

Fig. 4 – Typical Reverse Characteristics Per Leg

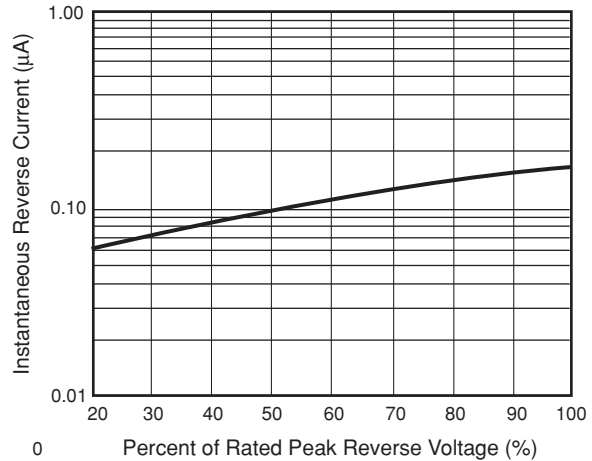

Fig. 5 – Typical Junction Capacitance Per Leg

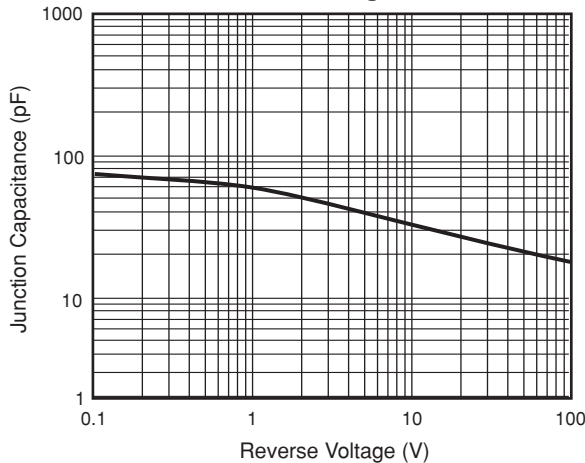

Fig. 6 – Typical Transient Thermal Impedance Per Leg

