



Obsolescence Notice

This product is obsolete.

This information is available for your convenience only.

For more information on Zarlink's obsolete products and replacement product lists, please visit http://products.zarlink.com/obsolete_products/

Features

- Contains two echo cancellers: 112ms acoustic echo canceller + 16ms line echo canceller
- Works with low cost voice codec. ITU-T G.711 or signed mag μ/A -Law, or linear 2's comp
- Each port may operate in different format.
- Advanced NLP design - full duplex speech with no switched loss on audio paths
- Fast re-convergence time: tracks changing echo environment quickly
- Adaptation algorithm converges even during Double-Talk
- Designed for exceptional performance in high background noise environments
- Provides protection against narrow-band signal divergence
- Howling prevention stops uncontrolled oscillation in high loop gain conditions
- Offset nulling of all PCM channels
- Serial micro-controller interface
- ST-BUS or variable-rate SSI PCM interfaces
- User gain control provided for speaker path (-24dB to +21dB in 3dB steps)
- AGC on speaker path

DS5038

ISSUE 3

February 1999

Ordering Information

MT9315AP	28 Pin PLCC
MT9315AE	28 Pin PDIP

-40 °C to + 85 °C

- Handles up to 0 dB acoustic echo return loss and 0dB line ERL
- Transparent data transfer and mute options
- 20 MHz master clock operation
- Low power mode during PCM Bypass

Applications

- Full duplex speaker-phone for digital telephone
- Echo cancellation for video conferencing
- Handsfree in automobile environment
- Full duplex speaker-phone for PC

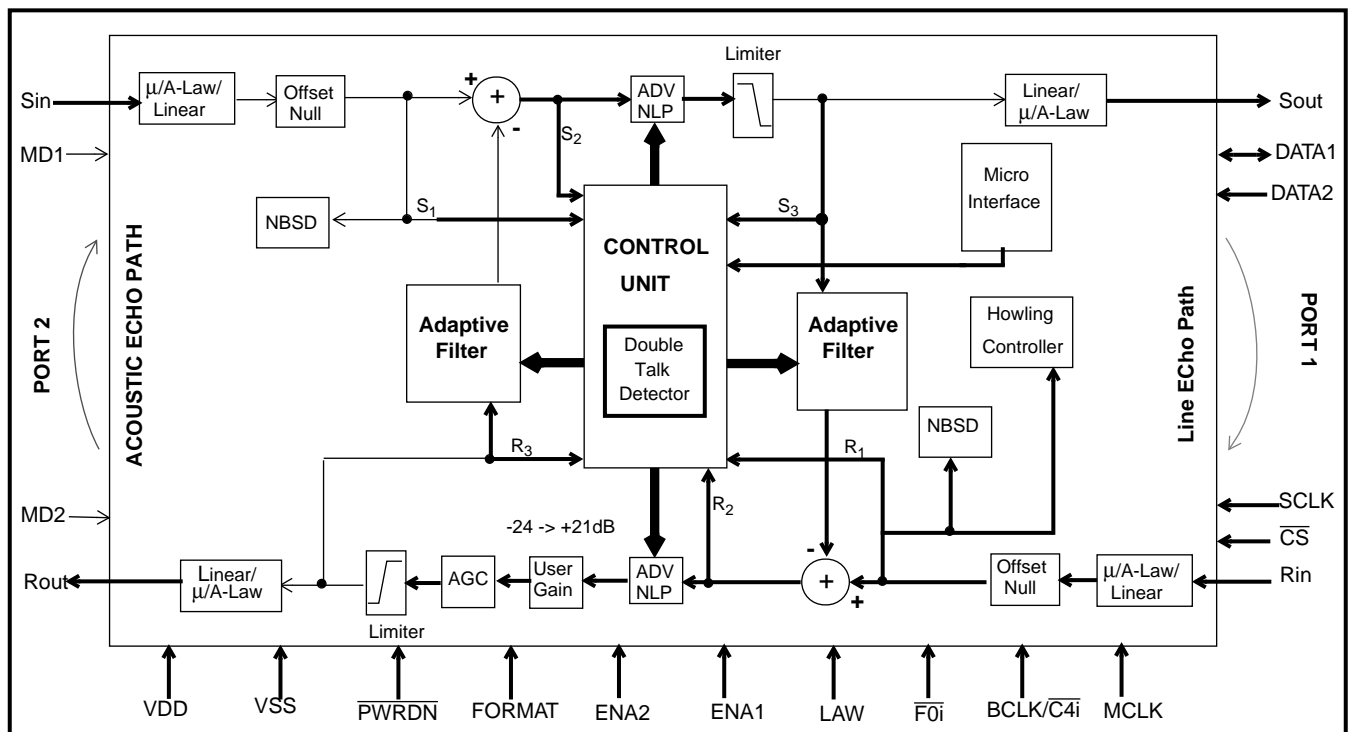

Figure 1 - Functional Block Diagram

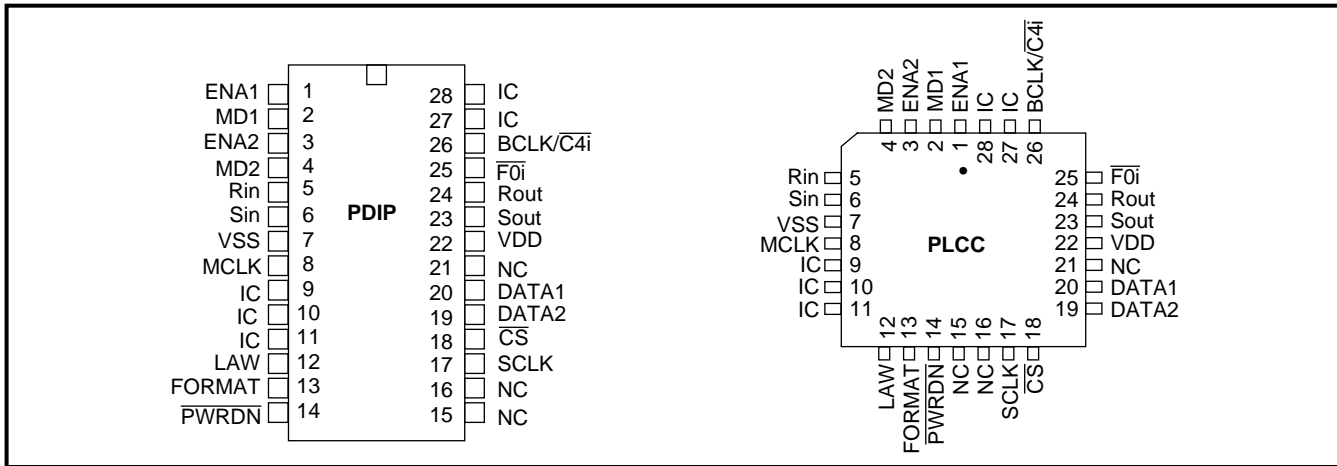

Figure 2 - Pin Connections

Pin Description

Pin #	Name	Description
1	ENA1	SSI Enable Strobe / ST-BUS Mode for Rin/Sout (Input). This pin has dual functions depending on whether SSI or ST-BUS is selected. For SSI, this strobe must be present for frame synchronization. This is an active high channel enable strobe, 8 or 16 data bits wide, enabling serial PCM data transfer for on Rin/Sout pins. Strobe period is 125 microseconds. For ST-BUS, this pin, in conjunction with the MD1 pin, will select the proper ST-BUS mode for Rin/Sout pins (see ST-BUS Operation description).
2	MD1	ST-BUS Mode for Rin/Sout (Input). When in ST-BUS mode, this pin, in conjunction with the ENA1 pin, will select the proper ST-BUS mode for Rin/Sout pins (see ST-BUS Operation description). Connect this pin to Vss in SSI mode.
3	ENA2	SSI Enable Strobe / ST-BUS Mode for Sin/Rout (Input). This pin has dual functions depending on whether SSI or ST-BUS is selected. For SSI, this is an active high channel enable strobe, 8 or 16 data bits wide, enabling serial PCM data transfer on Sin/Rout pins. Strobe period is 125 microseconds. For ST-BUS, this pin, in conjunction with the MD2 pin, will select the proper ST-BUS mode for Sin/Rout pins (see ST-BUS Operation description).
4	MD2	ST-BUS Mode for Sin/Rout (Input). When in ST-BUS mode, this pin in conjunction with the ENA2 pin, will select the proper ST-BUS mode for Sin/Rout pins (see ST-BUS Operation description). Connect this pin to Vss in SSI mode.
5	Rin	Receive PCM Signal Input (Input). 128 kbit/s to 4096 kbit/s serial PCM input stream. Data may be in either companded or 2's complement linear format. This is the Receive Input channel from the line (or line) side. Data bits are clocked in following SSI or ST-BUS timing requirements.
6	Sin	Send PCM Signal Input (Input). 128 kbit/s to 4096 kbit/s serial PCM input stream. Data may be in either companded or 2's complement linear format. This is the Send Input channel (from the microphone). Data bits are clocked in following SSI or ST-BUS timing requirements.
7	VSS	Digital Ground: Nominally 0 volt.
8	MCLK	Master Clock (Input): Nominal 20 MHz Master Clock input. May be connected to an asynchronous (relative to frame signal) clock source.
9	IC	Internal Connection (Input): Must be tied to Vss.
10, 11	IC	Internal Connection (Input). Tie to Vss.
12	LAW	A/μ Law Select (Input). When low, selects μ-Law companded PCM. When high, selects A-Law companded PCM. This control is for both serial pcm ports.

Pin Description (continued)

Pin #	Name	Description
13	FORMAT	ITU-T/Sign Mag (Input). When low, selects sign-magnitude PCM code. When high, selects ITU-T (G.711) PCM code. This control is for both serial pcm ports.
14	$\overline{\text{PWRDN}}$	Power-down (Input). An active low resets the device and puts the MT9315 into a low-power stand-by mode.
15, 16	NC	No Connect (Output). This pin should be left un-connected.
17	SCLK	Serial Port Synchronous Clock (Input). Data clock for the serial microport interface.
18	$\overline{\text{CS}}$	Serial Port Chip Select (Input). Enables serial microport interface data transfers. Active low.
19	DATA2	Serial Data Receive (Input). In Motorola/National serial microport operation, the DATA2 pin is used for receiving data. In Intel serial microport operation, the DATA2 pin is not used and must be tied to Vss or Vdd.
20	DATA1	Serial Data Port (Bidirectional). In Motorola/National serial microport operation, the DATA1 pin is used for transmitting data. In Intel serial microport operation, the DATA1 pin is used for transmitting and receiving data.
21	NC	No Connect (Output). This pin should be left un-connected.
22	VDD	Positive Power Supply. Nominal is 5V
23	Sout	Send PCM Signal Output (Output). 128 kbit/s to 4096 kbit/s serial PCM output stream. Data may be in either companded or 2's complement linear PCM format. This is the Send Out signal after acoustic echo cancellation and Non-linear processing. Data bits are clocked out following SSI or ST-BUS timing requirements.
24	Rout	Receive PCM Signal Output (Output). 128 kbit/s to 4096 kbit/s serial PCM output stream. Data may be in either companded or 2's complement linear PCM format. This is the Receive out signal after line echo cancellation Non-linear processing, AGC, and gain control. Data bits are clocked out following SSI or ST-BUS timing requirements.
25	$\overline{\text{F0i}}$	Frame Pulse (Input). In ST-BUS operation, this is an active-low frame alignment pulse. SSI operation is enabled by connecting this pin to Vss.
26	BCLK/ $\overline{\text{C4i}}$	Bit Clock/ST-BUS Clock (Input). In SSI operation, BCLK pin is a 128 kHz to 4.096 MHz bit clock. This clock must be synchronous with ENA1, and ENA2 enable strobes. In ST-BUS operation, $\overline{\text{C4i}}$ pin must be connected to the 4.096MHz (C4) system clock.
27, 28	IC	Internal Connection (Input). Tie to Vss.

Notes:

- All inputs have TTL compatible logic levels except for MCLK, Sin and Rin pins which have CMOS compatible logic levels and $\overline{\text{PWRDN}}$ pin which has Schmitt trigger compatible logic levels.
- All outputs are CMOS pins with CMOS logic levels except DATA1 which is TTL bidirectional.

Glossary

Double-Talk	Simultaneous signals present on Rin and Sin.
Near-end Single-Talk	Signals only present at Sin input.
Far-end Single-Talk	Signals only present at Rin input.
ADV NLP	Advanced Non-Linear-Processor
Howling	Oscillation caused by feedback from acoustic and line echo paths
Narrowband	Any mono or dual sinusoidal signals
NBSD	Narrow Band Signal Detector
Noise-Gating	Audible switching of background noise
Offset Nulling	Removal of DC component
Reverberation time	The time duration before an echo level decays to -60dBm
ERL	Echo Return Loss
ERLE	Echo Return Loss Enhancement
AGC	Automatic Gain Control

Functional Description

The MT9315 device contains two echo cancellers, as well as the many control functions necessary to operate the echo cancellers. One canceller is for acoustic speaker to microphone echo, and one for line echo cancellation. The MT9315 provides clear signal transmission in both audio path directions to ensure reliable voice communication, even with low level signals. The MT9315 does not use variable attenuators during double-talk or single-talk periods of speech, as do many other acoustic echo cancellers for speaker-phones. Instead, the MT9315 provides high performance full-duplex operation similar to network echo cancellers, so that users experience clear speech and un-interrupted background signals during the conversation. This prevents subjective sound quality problems associated with “noise gating” or “noise contrasting”.

The MT9315 uses an advanced adaptive filter algorithm that is double-talk stable, which means that convergence takes place even while both parties are talking ¹. This algorithm allows continual tracking of changes in the echo path, regardless of double-talk, as long as a reference signal is available for the echo canceller.

(1. Patent Pending)

The echo tail cancellation capability of the acoustic echo canceller has been sized appropriately (112ms) to cancel echo in an average sized office with a reverberation time of less than 112ms. The 16ms line echo canceller is sufficient to ensure a high ERLE for most line circuits.

In addition to the echo cancellers, the following functions are supported:

- Control of adaptive filter convergence speed during periods of double-talk, far end single-talk, and near-end echo path changes.
- Control of Non-Linear Processor thresholds for suppression of residual non-linear echo.
- Howling detector to identify when instability is starting to occur, and to take action to prevent oscillation.
- Narrow-Band Detector for preventing adaptive filter divergence caused by narrow-band signals
- Offset Nulling filters for removal of DC components in PCM channels.
- Limiters that introduce controlled saturation levels.
- Serial controller interface compatible with Motorola, National and Intel microcontrollers.
- PCM encoder/decoder compatible with μ /A-

Law ITU-T G.711, μ /A-Law Sign-Mag or linear 2's complement coding.

- Automatic gain control on the receive speaker path.

Adaptation Speed Control

The adaptation speed of the acoustic echo canceller is designed to optimize the convergence speed versus divergence caused by interfering near-end signals. Adaptation speed algorithm takes into account many different factors such as relative double-talk condition, far end signal power, echo path change, and noise levels to achieve fast convergence.

Advanced Non-Linear Processor (ADV-NLP)²

(2. Patent Pending)

After echo cancellation, there is likely to be residual echo which needs to be removed so that it will not be audible. The MT9315 uses an NLP to remove low level residual echo signals which are not comprised of background noise. The operation of the NLP depends upon a dynamic activation threshold, as well as a double-talk detector which disables the NLP during double-talk periods.

The MT9315 keeps the perceived noise level constant, without the need for any variable attenuators or gain switching that causes audible “noise gating”. The noise level is constant and identical to the original background noise even when the NLP is activated.

For each audio path, the NLP can be disabled by setting the NLP- bit to 1 in the LEC or AEC control registers.

Narrow Band Signal Detector (NBSD)³

(3. Patent Pending)

Single or multi-frequency tones (e.g. DTMF, or signalling tones) present in the reference input of an echo canceller for a prolonged period of time may cause the adaptive filter to diverge. The Narrow Band Signal Detector (NBSD) is designed to prevent this divergence by detecting single or multi-tones of arbitrary frequency, phase, and amplitude. When narrow band signals are detected, the filter adaptation process is stopped but the echo canceller continues to cancel echo.

The NBSD can be disabled by setting the NB- bit to 1 in the MC control registers.

Howling Detector (HWLD) ⁴*(4. Patent Pending)*

The Howling detector is part of an Anti-Howling control, designed to prevent oscillation as a result of positive feedback in the audio paths.

The HWLD can be disabled by setting the AH- bit to 1 in the (MC) control register.

Offset Null Filter

To ensure robust performance of the adaptive filters at all times, any DC offset that may be present on either the Rin signal or the Sin signal, is removed by highpass filters. These filters have a corner frequency placed at 40Hz.

The offset null filters can be disabled by setting the HPF- bit to 1 in the LEC or AEC control registers.

Limiters

To prevent clipping in the echo paths, two limiters with variable thresholds are provided at the outputs.

The Rout limiter threshold is in Rout Limiter Register 1 and 2. The Sout limiter threshold is in Sout Limiter Register. Both output limiters are always enabled.

User Gain

The user gain function provides the ability for users to adjust the audio gain in the receive path (speaker path). This gain is adjustable from -24dB to +21dB in 3dB steps. It is important to use ONLY this user gain function to adjust the speaker volume. The user gain function in the MT9315 is optimally placed between the two echo cancellers such that no reconvergence is necessary after gain changes.

The gain can be accessed through Receive Gain Control Register.

AGC

The AGC function is provided to limit the volume in the speaker path. The gain of the speaker path is automatically reduced during the following conditions:

- When clipping of the receive signal occurs.
- When initial convergence of the acoustic echo canceller detects unusually large echo return.
- When howling is detected.

The AGC can be disabled by setting the AGC- bit to 1 in MC control register.

Mute Function

A pcm mute function is provided for independent control of the Receive and Send audio paths. Setting the MUTE_R or MUTE_S bit in the MC register, causes quiet code to be transmitted on the Rout or Sout paths respectively.

Quiet code is defined according to the following table.

	LINEAR 16 bits 2's complement	SIGN/ MAGNITUDE μ-Law A-Law	CCITT (G.711)	
			μ-Law	A-Law
+Zero (quiet code)	0000h	80h	FFh	D5h

Table 1 - Quiet PCM Code Assignment

Bypass Control

A PCM bypass function is provided to allow transparent transmission of pcm data through the MT9315. When the bypass function is active, pcm data passes transparently from Rin to Rout and from Sin to Sout, with bit-wise integrity preserved.

When the Bypass function is selected, most internal functions are powered down to provide low power consumption.

The BYPASS control bit is located in the main control MC register.

Adaptation Enable/Disable

Adaptation control bits are located in the AEC and LEC control registers. When the ADAPT- bit is set to 1, the adaptive filter is frozen at the current state. In this state, the device continues to cancel echo with the current echo model.

When the ADAPT- bit is set to 0, the adaptive filter is continually updated. This allows the echo canceller to adapt and track changes in the echo path. This is the normal operating state.

MT9315 Throughput Delay

In all modes, voice channels always have 2 frames of delay. In ST-BUS operation, the D and C channels have a delay of one frame.

Power Down

Forcing the $\overline{\text{PWRDN}}$ pin to logic low, will put the MT9315 into a power down state. In this state all internal clocks are halted, the DATA1, Sout and Rout pins are tristated.

The user should hold the $\overline{\text{PWRDN}}$ pin low for 200 msec on Power-up. This will insure that the device powers up in a proper state.

The device will automatically begin the execution of initialization routines when the $\overline{\text{PWRDN}}$ pin is returned to logic high and a clock is applied to the MCLK pin. The initialization routines execute for one frame and will set the MT9315 to default register values.

After power down, the user waits for 2 complete 8 KHz frames prior to writing to the device registers.

PCM Data I/O

The PCM data transfer for the MT9315 is provided through two PCM ports. One port consists of Rin and Sout pins while the second port consists of Sin and Rout pins. The data are transferred through these ports according to either ST-BUS or SSI conventions. The device determines the convention by monitoring the signal applied to the $\overline{\text{FOi}}$ pin. When a valid ST-BUS frame pulse is applied to the $\overline{\text{FOi}}$ pin, the MT9315 will assume ST-BUS operation. If $\overline{\text{FOi}}$ is tied continuously to Vss, the MT9315 will assume SSI operation.

ST-BUS Operation

The ST-BUS PCM interface conforms to Mitel's ST-BUS standard and it is used to transport 8 bit companded PCM data (using one timeslot) or 16 bit 2's complement linear PCM data (using two timeslots). The MD1/ENA1 pins select the timeslot on the Rin/Sout port while the MD2/ENA2 pin selects the timeslot on the Sin/Rout port. See Table 2 and Figures 3 to 6.

PORT1 Rin/Sout		ST-BUS Mode Selection	PORT2 Sin/Rout	
Enable Pins			Enable Pins	
MD1	ENA1		MD2	ENA2
0	0	Mode 1. 8 bit companded PCM I/O on timeslot 0	0	0
0	1	Mode 2. 8 bit companded PCM I/O on timeslot 2.	0	1
1	0	Mode 3. 8 bit companded PCM I/O on timeslot 2. Includes D & C channel bypass in timeslots 0 & 1.	1	0
1	1	Mode 4. 16 bit 2's complement linear PCM I/O on timeslots 0 & 1.	1	1

Table 2 - ST-BUS Mode Select

SSI Operation

The SSI PCM interface consists of data input pins (Rin, Sin), data output pins (Sout, Rout), a variable rate bit clock (BCLK), and two enable pins (ENA1, ENA2) to provide strobes for data transfers. The active high enable may be either 8 or 16 BCLK cycles in duration. Automatic detection of the data type (8 bit companded or 16 bit 2's complement linear) is accomplished internally. The data type cannot change dynamically from one frame to the next.

In SSI operation, the frame boundary is determined by the rising edge of the ENA1 enable strobe (see Figure 7). The other enable strobe (ENA2) is used for parsing input/output data and it must pulse within 125 microseconds of the rising edge of ENA1.

In SSI operation, the enable strobes may be a mixed combination of 8 or 16 BCLK cycles allowing the flexibility to mix 2's complement linear data on one port (e.g., Rin/Sout) with companded data on the other port (e.g., Sin/Rout).

Enable Strobe Pin	Designated PCM I/O Port
ENA1	Line Side Echo Path (PORT 1)
ENA2	Acoustic Side Echo Path (PORT 2)

Table 3 - SSI Enable Strobe Pins

PCM Law and Format Control (LAW, FORMAT)

The PCM companding/coding law used by the MT9315 is controlled through the LAW and FORMAT pins. ITU-T G.711 companding curves for μ -Law and A-Law are selected by the LAW pin. PCM coding ITU-T G.711 and Sign-Magnitude are selected by the FORMAT pin. See Table 4.

PCM Code	Sign-Magnitude	ITU-T (G.711)	
	FORMAT=0	FORMAT=1	
	μ /A-LAW LAW = 0 or 1	μ -LAW LAW = 0	A-LAW LAW = 1
+ Full Scale	1111 1111	1000 0000	1010 1010
+ Zero	1000 0000	1111 1111	1101 0101
- Zero	0000 0000	0111 1111	0101 0101
- Full Scale	0111 1111	0000 0000	0010 1010

Table 4 - Companded PCM

Linear PCM

The 16-bit 2's complement PCM linear coding permits a dynamic range beyond that which is specified in ITU-T G.711 for companded PCM. The echo-cancellation algorithm will accept 16 bits 2's complement linear code which gives a maximum signal level of +15dBm0.

Bit Clock (BCLK/C4i)

The BCLK/ $\overline{C4i}$ pin is used to clock the PCM data in both SSI (BCLK) and ST-BUS ($\overline{C4i}$) operations.

In SSI operation, the bit rate is determined by the BCLK frequency. This input must contain either eight or sixteen clock cycles within the valid enable strobe window. BCLK may be any rate between 128 KHz to 4.096 MHz and can be discontinuous outside of the enable strobe windows defined by ENA1, ENA2 pins. Incoming PCM data (Rin, Sin) are sampled on the falling edge of BCLK while outgoing PCM data (Sout, Rout) are clocked out on the rising edge of BCLK. See Figure 11.

In ST-BUS operation, connect the system $\overline{C4}$ (4.096MHz) clock to the $\overline{C4i}$ pin.

Master Clock (MCLK)

A nominal 20MHz master clock (MCLK) is required. The MCLK input may be asynchronous with the 8KHz frame.

Microport

The serial microport provides access to all MT9315 internal read and write registers. This microport is compatible with Intel MCS-51 (mode 0), Motorola SPI (CPOL=0, CPHA=0), and National Semiconductor Microwire specifications. The

microport consists of a transmit/receive data pin (DATA1), a receive data pin (DATA2), a chip select pin (\overline{CS}) and a synchronous data clock pin (SCLK).

The MT9315 automatically adjusts its internal timing and pin configuration to conform to Intel or Motorola/National requirements. The microport dynamically senses the state of the SCLK pin each time \overline{CS} pin becomes active (i.e. high to low transition). If SCLK pin is high during \overline{CS} activation, then Intel mode 0 timing is assumed. In this case DATA1 pin is defined as a bi-directional (transmit/receive) serial port and DATA2 is internally disconnected. If SCLK is low during \overline{CS} activation, then Motorola/National timing is assumed and DATA1 is defined as the data transmit pin while DATA2 becomes the data receive pin. The MT9315 supports Motorola half-duplex processor mode (CPOL=0 and CPHA=0). This means that during a write to the MT9315, by the Motorola processor, output data from the DATA1 pin must be ignored. This also means that input data on the DATA2 pin is ignored by the MT9315 during a valid read by the Motorola processor.

All data transfers through the microport are two bytes long. This requires the transmission of a Command/Address byte followed by the data byte to be written to or read from the addressed register. \overline{CS} must remain low for the duration of this two-byte transfer. As shown in Figures 8 and 9, the falling edge of \overline{CS} indicates to the MT9315 that a microport transfer is about to begin. The first 8 clock cycles of SCLK after the falling edge of \overline{CS} are always used to receive the Command/Address byte from the microcontroller. The Command/Address byte contains information detailing whether the second byte transfer will be a read or a write operation and at what address. The next 8 clock cycles are used to transfer the data byte between the MT9315 and the microcontroller. At the end of the two-byte transfer, \overline{CS} is brought high again to terminate the session. The rising edge of \overline{CS} will tri-state the DATA1 pin. The DATA1 pin will remain tri-stated as long as \overline{CS} is high.

Intel processors utilize Least Significant Bit (LSB) first transmission while Motorola/National processors use Most Significant Bit (MSB) first transmission. The MT9315 microport automatically accommodates these two schemes for normal data bytes. However, to ensure timely decoding of the R/W and address information, the Command/Address byte is defined differently for Intel and Motorola/National operations. Refer to the relative timing diagrams of Figure 8 and Figure 9.

Receive data bits are sampled on the rising edge of SCLK while transmit data is clocked out on the falling edge of SCLK. Detailed microport timing is shown in Figure 13 and Figure 14.

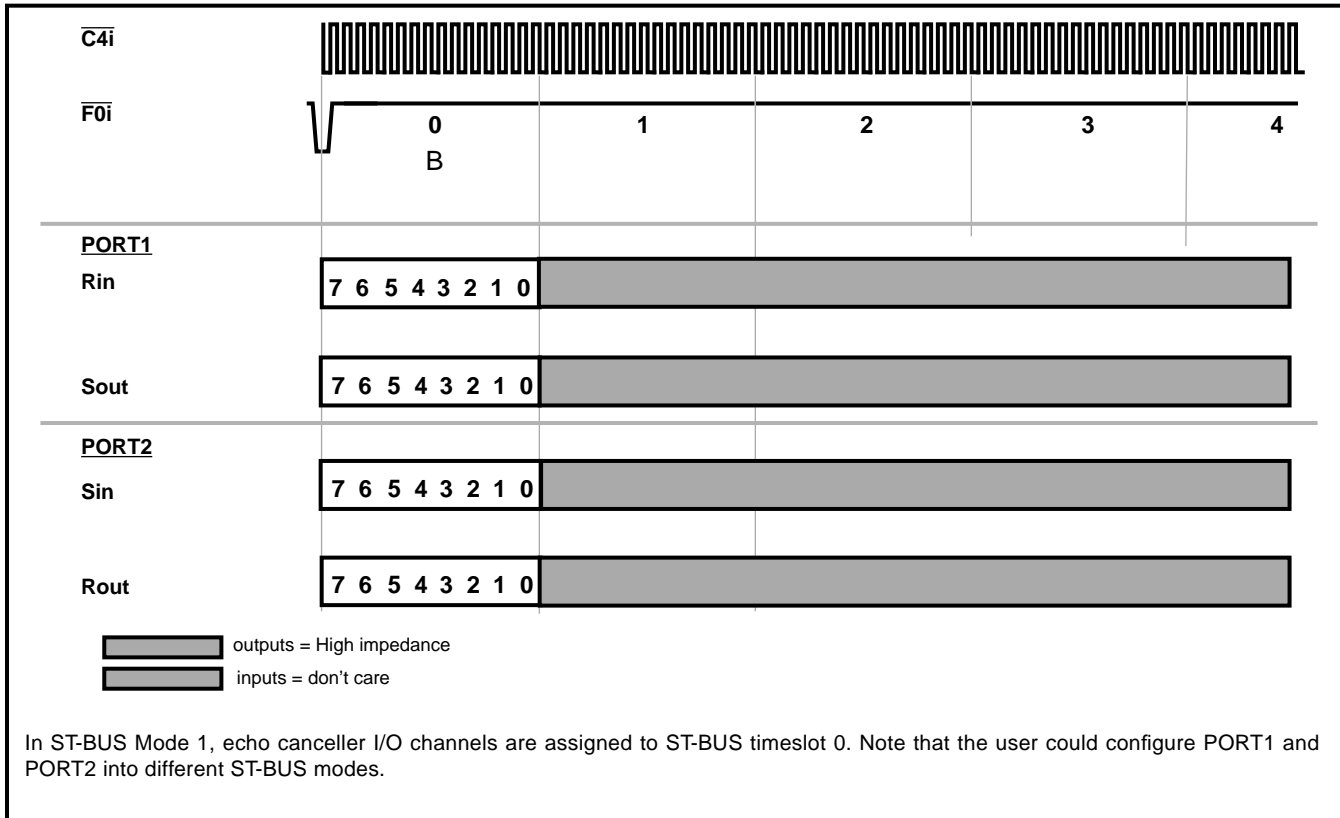

Figure 3 - ST-BUS 8 Bit Companded PCM I/O on Timeslot 0 (Mode 1)

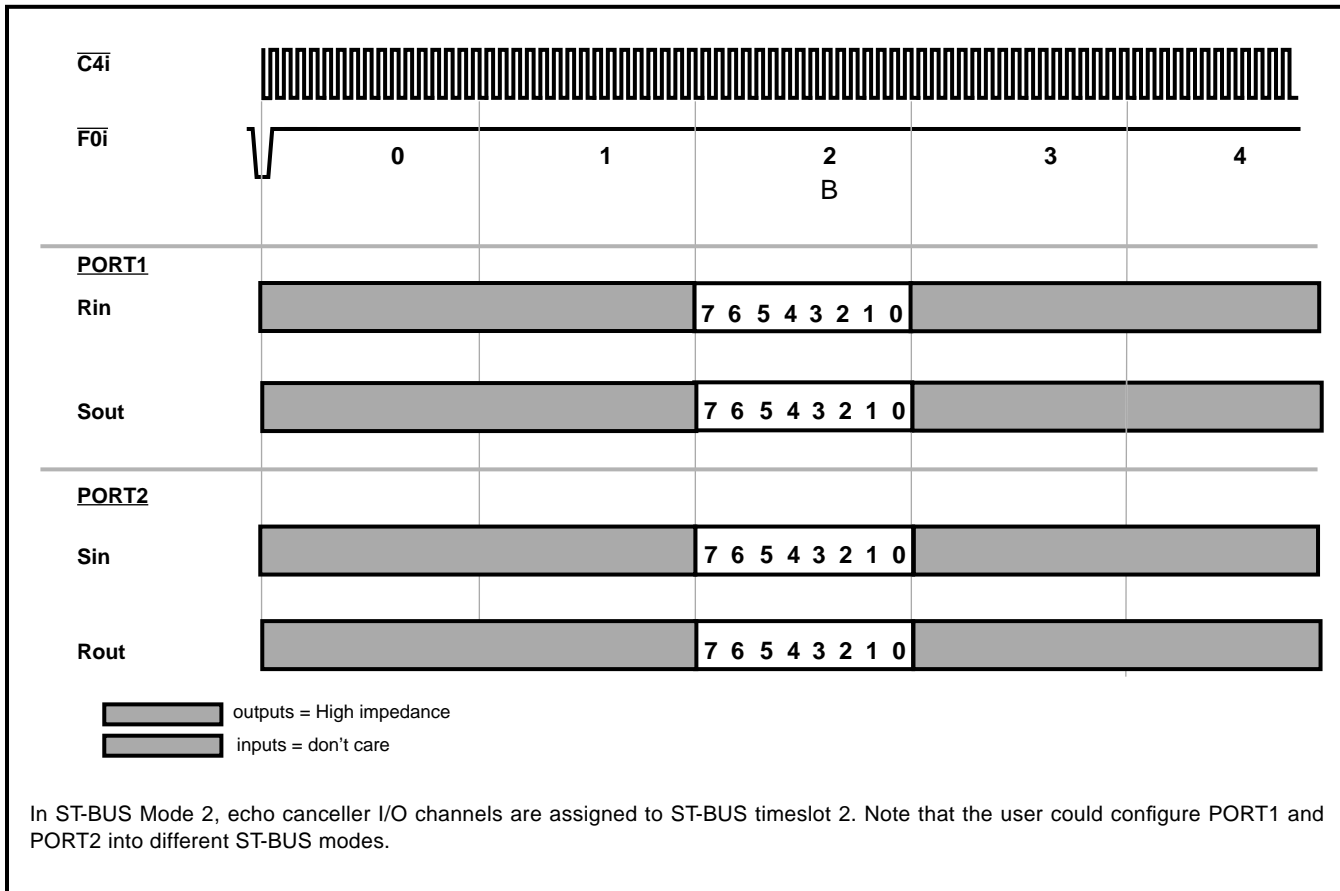

Figure 4 - ST-BUS 8 Bit Companded PCM I/O on Timeslot 2 (Mode 2)

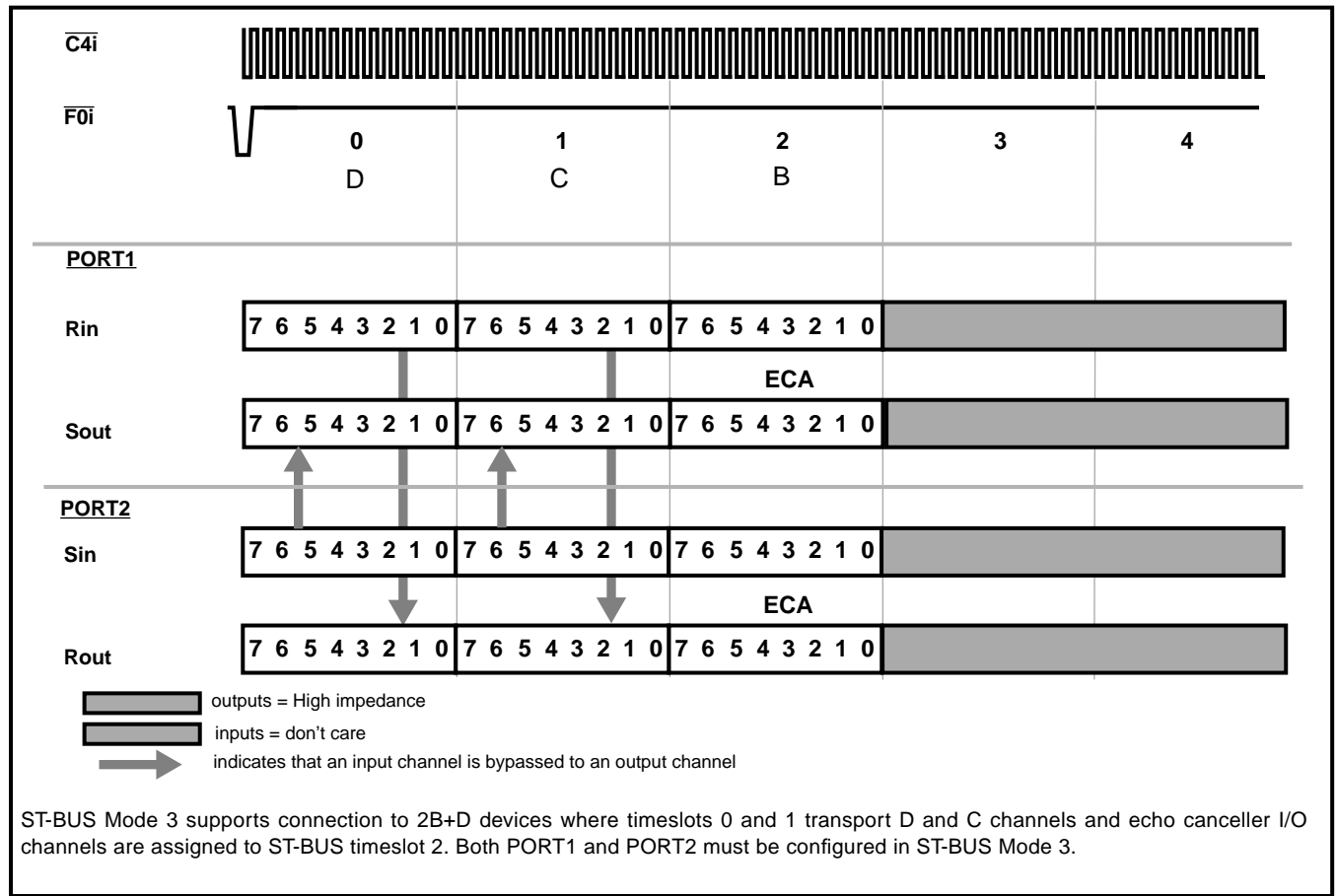

Figure 5 - ST-BUS 8 Bit Companded PCM I/O with D and C channels (Mode 3)

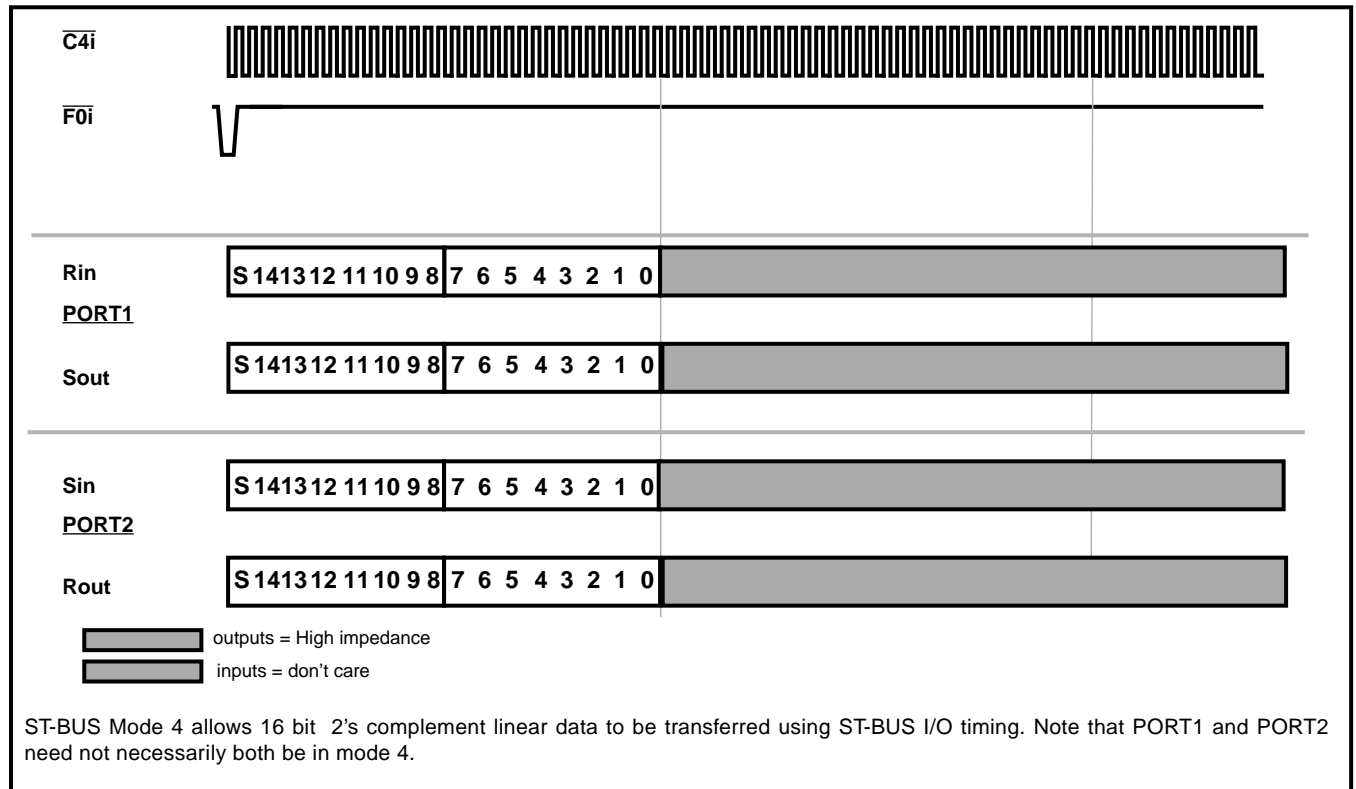

Figure 6 - ST-BUS 16 Bit 2's complement linear PCM I/O (Mode 4)

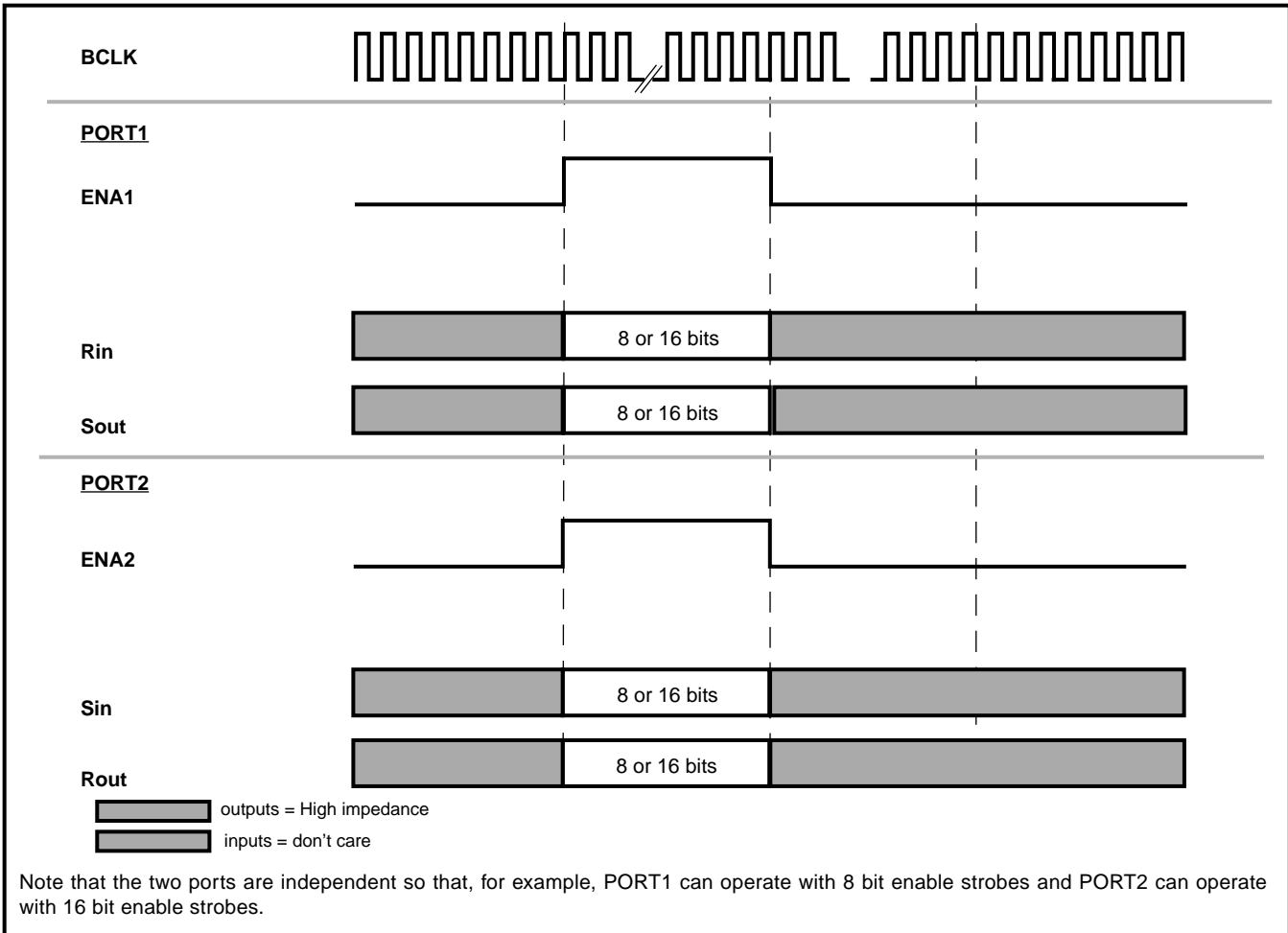

Figure 7 - SSI Operation

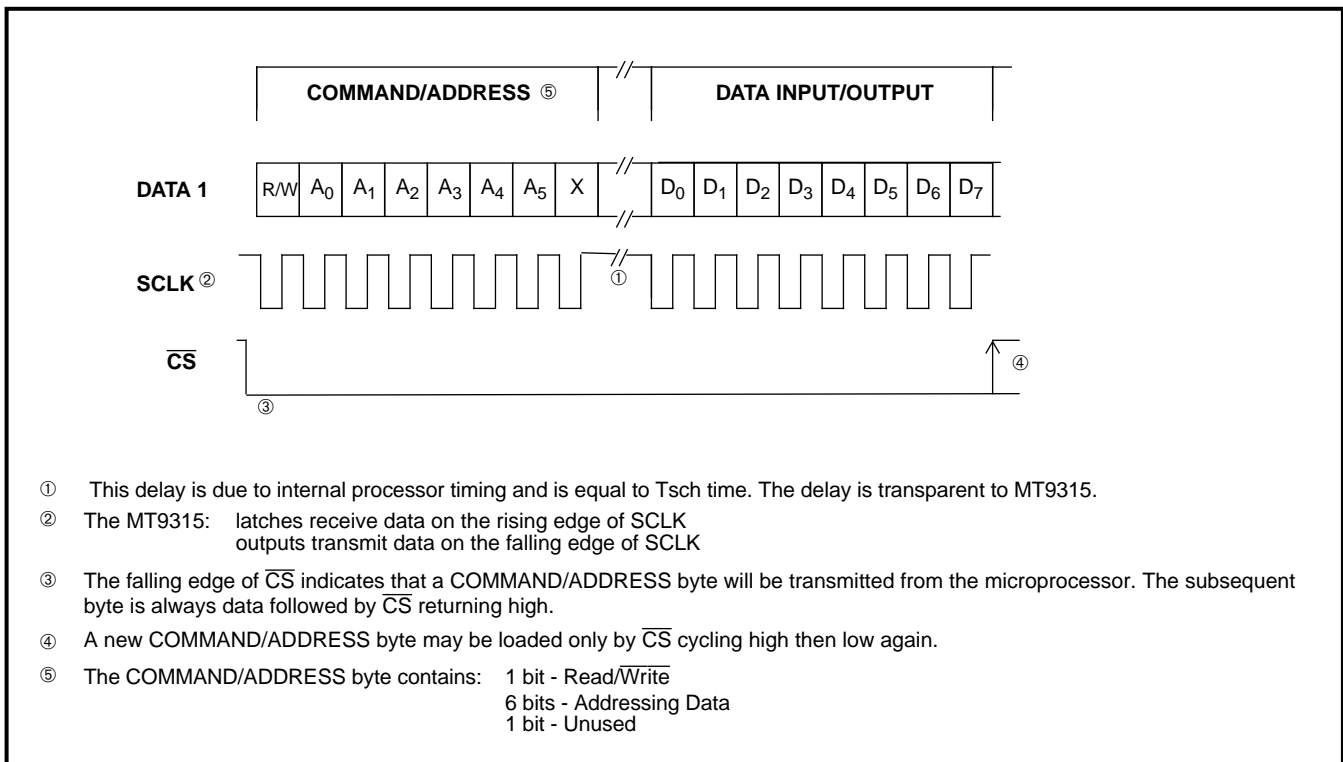

Figure 8 - Serial Microport Timing for Intel Mode 0

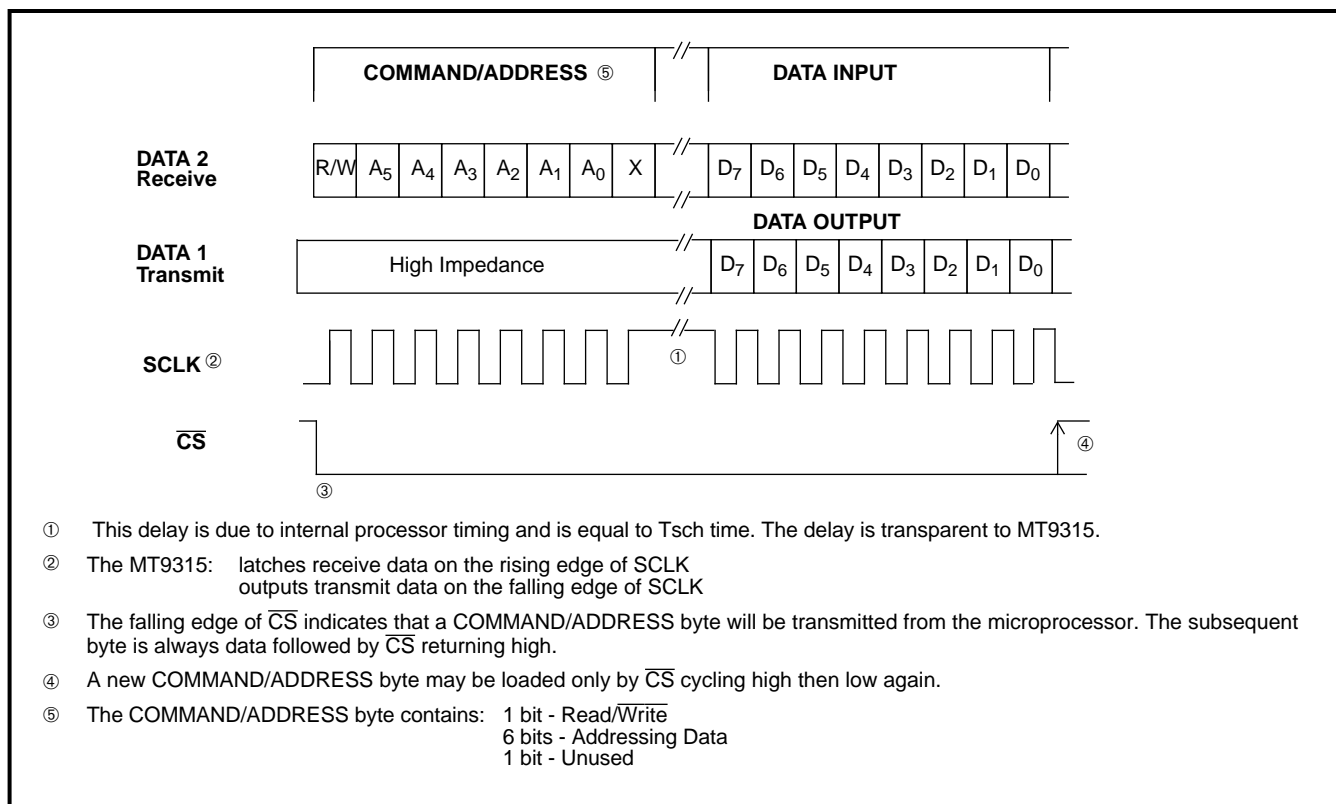

Figure 9 - Serial Microport Timing for Motorola Mode 00 or National Microwire

Absolute Maximum Ratings*

	Parameter	Symbol	Min	Max	Units
1	Supply Voltage	$V_{DD}-V_{SS}$	-0.3	7.0	V
2	Input Voltage	V_i	$V_{SS}-0.3$	$V_{DD}+ 0.3$	V
3	Output Voltage Swing	V_o	$V_{SS}-0.3$	$V_{DD}+ 0.3$	V
4	Continuous Current on any digital pin	$I_{i/o}$		± 20	mA
5	Storage Temperature	T_{ST}	-65	150	°C
6	Package Power Dissipation	$P_D(5v)$		500	mW

* Exceeding these values may cause permanent damage. Functional operation under these conditions is not implied.

Recommended Operating Conditions - Voltages are with respect to ground (V_{SS}) unless otherwise stated

	Characteristics	Sym	Min	Typ	Max	Units	Test Conditions
1	Supply Voltage	V_{DD}	4.5	5.0	5.5	V	
2	TTL Input High Voltage		2.4		V_{DD}	V	
3	TTL Input Low Voltage		V_{SS}		0.4	V	
4	CMOS Input High Voltage		2.1		V_{DD}	V	
5	CMOS Input Low Voltage		V_{SS}		0.5	V	
6	Operating Temperature	T_A	-40		+85	°C	

Echo Return Limits -

	Characteristics	Min	Typ	Max	Units	Test Conditions
1	Acoustic Echo Return			0	dB	Measured from Rout -> Sin
2	Line Echo Return			0	dB	Measured from Sout -> Rin

DC Electrical Characteristics* - Voltages are with respect to ground (V_{SS}) unless otherwise stated.

	Characteristics	Sym	Min	Typ [‡]	Max	Units	Conditions/Notes
1	Standby Supply Current:	I_{CC}			60	μA	$\overline{PWRDN} = 0$
	Operating Supply Current:	I_{DD}		50		mA	$\overline{PWRDN} = 1$, clocks active
2	Input HIGH voltage (TTL)	V_{IH}	2.0			V	All except MCLK,Sin,Rin
3	Input LOW voltage (TTL)	V_{IL}			0.8	V	All except MCLK,Sin,Rin
4	Input HIGH voltage (CMOS)	V_{IHC}	$0.7V_{DD}$			V	MCLK,Sin,Rin
5	Input LOW voltage (CMOS)	V_{ILC}			$0.3V_{DD}$	V	MCLK,Sin,Rin
6	Input leakage current	I_{IH}/I_{IL}		0.1	10	μA	$V_{IN}=V_{SS}$ to V_{DD}
7	High level output voltage	V_{OH}	$0.9V_{DD}$			V	$I_{OH}=2.5mA$
8	Low level output voltage	V_{OL}			$0.1V_{DD}$	V	$I_{OL}=5.0mA$
9	High impedance leakage	I_{OZ}		1	10	μA	$V_{IN}=V_{SS}$ to V_{DD}
10	Output capacitance	C_o		10		pF	

DC Electrical Characteristics* - Voltages are with respect to ground (V_{SS}) unless otherwise stated.

	Characteristics	Sym	Min	Typ [‡]	Max	Units	Conditions/Notes
11	Input capacitance	C_i		8		pF	
12	\overline{PWRDN} Positive Threshold Voltage Hysteresis Negative Threshold Voltage	V_+ V_H V_-	$0.75V_{DD}$	1.0	$0.25V_{DD}$	V V V	

[‡] Typical figures are at 25°C and are for design aid only; not guaranteed and not subject to production testing.

*DC Electrical Characteristics are over recommended temperature and supply voltage.

AC Electrical Characteristics[†] - Serial Data Interfaces - Voltages are with respect to ground (V_{SS}) unless otherwise stated

	Characteristics	Sym	Min	Typ	Max	Units	Test Notes
1	MCLK Clock High	t_{MCH}	20			ns	
2	MCLK Clock Low	t_{MCL}	20			ns	
3	MCLK Frequency	f_{CLK}	19.15		20.5	MHz	
4	$\overline{BCLK/C4i}$ Clock High	t_{BCH} , t_{C4H}	90			ns	
5	$\overline{BCLK/C4i}$ Clock Low	t_{BLL} , t_{C4L}	90			ns	
6	$\overline{BCLK/C4i}$ Period	t_{BCP}	240		7900	ns	
7	SSI Enable Strobe to Data Delay (first bit)	t_{SD}	80			ns	$C_L=150pF$
8	SSI Data Output Delay (excluding first bit)	t_{DD}	80			ns	$C_L=150pF$
9	SSI Output Active to High Impedance	t_{AHZ}	80			ns	$C_L=150pF$
10	SSI Enable Strobe Signal Setup	t_{SSS}	10		t_{BCP} -15	ns	
11	SSI Enable Strobe Signal Hold	t_{SSH}	15		t_{BCP} -10	ns	
12	SSI Data Input Setup	t_{DIS}	10			ns	
13	SSI Data Input Hold	t_{DIH}	15			ns	
14	$\overline{F0i}$ Setup	t_{F0iS}	20		150	ns	
15	$\overline{F0i}$ Hold	t_{F0iH}	20		150	ns	
16	ST-BUS Data Output delay	t_{DSD}	80			ns	$C_L=150pF$
17	ST-BUS Output Active to High Impedance	t_{ASHZ}	80			ns	$C_L=150pF$
18	ST-BUS Data Input Hold time	t_{DSH}	20			ns	
19	ST-BUS Data Input Setup time	t_{DSS}	20			ns	

[†] Timing is over recommended temperature and power supply voltages.

AC Electrical Characteristics[†] - Microport Timing

	Characteristics	Sym	Min	Typ	Max	Units	Test Notes
1	Input Data Setup	t_{IDS}	100			ns	
2	Input Data Hold	t_{IDH}	30			ns	
3	Output Data Delay	t_{ODD}	100			ns	$C_L=150pF$
4	Serial Clock Period	t_{SCP}	500			ns	
5	SCLK Pulse Width High	t_{SCH}	250			ns	
6	SCLK Pulse Width Low	t_{SCL}	250			ns	
7	\overline{CS} Setup-Intel	t_{CSSI}	200			ns	
8	\overline{CS} Setup-Motorola	t_{CSSM}	100			ns	
9	\overline{CS} Hold	t_{CSH}	100			ns	
10	\overline{CS} to Output High Impedance	t_{OHZ}	100			ns	$C_L=150pF$

[†] Timing is over recommended temperature range and recommended power supply voltages.

Characteristic	Symbol	TTL Pin	CMOS Pin	Units
TTL reference level	V_{TT}	1.5	-	V
CMOS reference level	V_{CT}	-	$0.5 \cdot V_{DD}$	V
Input HIGH level	V_H	2.4	$0.9 \cdot V_{DD}$	V
Input LOW level	V_L	0.4	$0.1 \cdot V_{DD}$	V
Rise/Fall HIGH measurement point	V_{HM}	2.0	$0.7 \cdot V_{DD}$	V
Rise/Fall LOW measurement point	V_{HL}	0.8	$0.3 \cdot V_{DD}$	V

Table 8 - Reference Level Definition for Timing Measurements

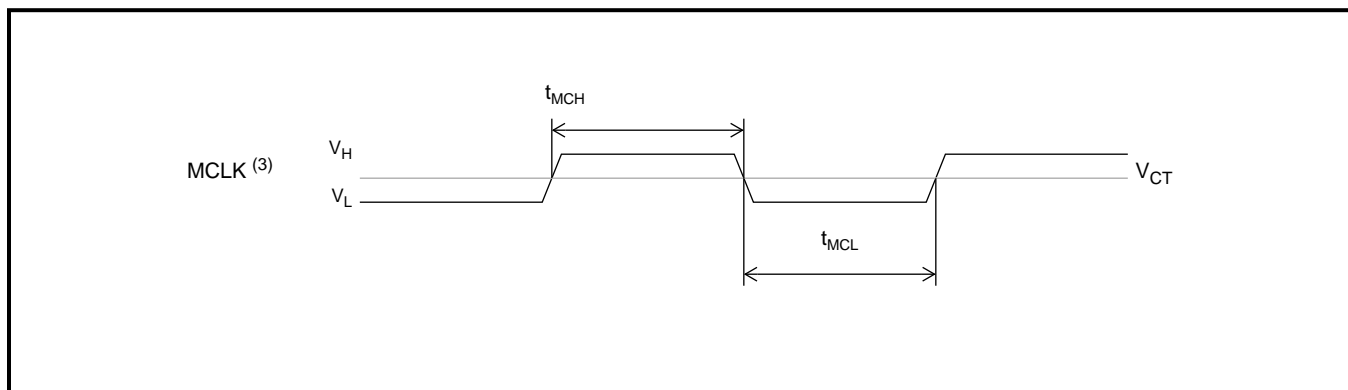

Figure 10 - Master Clock - MCLK

- Notes: 1. CMOS output
 2. TTL input compatible
 3. CMOS input
 (see Table 8 for symbol definitions)

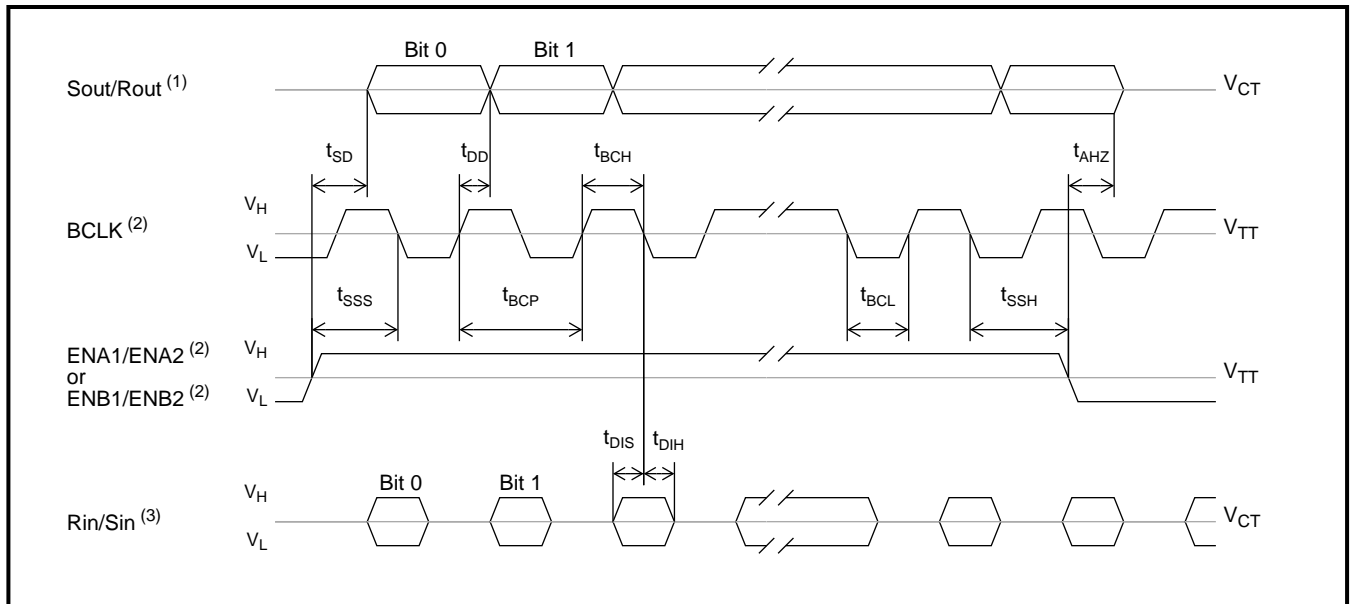

Figure 11 - SSI Data Port Timing

- Notes: 1. CMOS output
 2. TTL input compatible
 3. CMOS input
 (see Table 8 for symbol definitions)

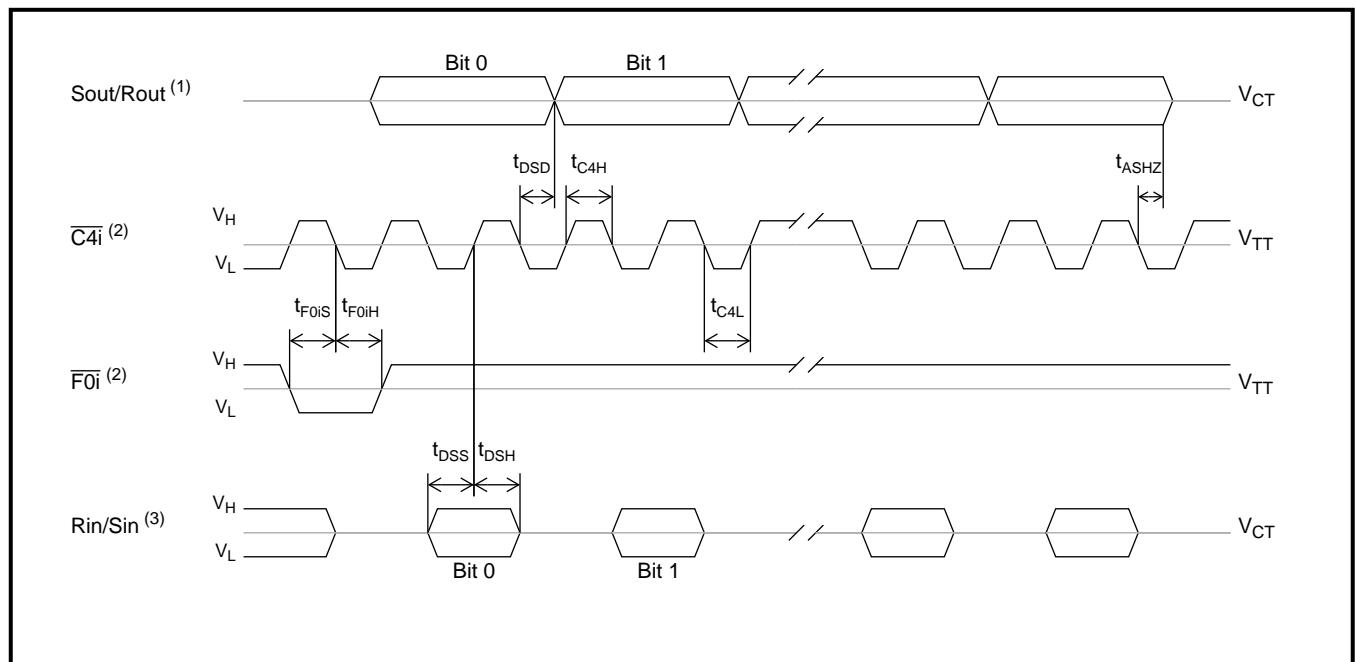

Figure 12 - ST-BUS Data Port Timing

- Notes: 1. CMOS output
 2. TTL input compatible
 3. CMOS input
 (see Table 8 for symbol definitions)

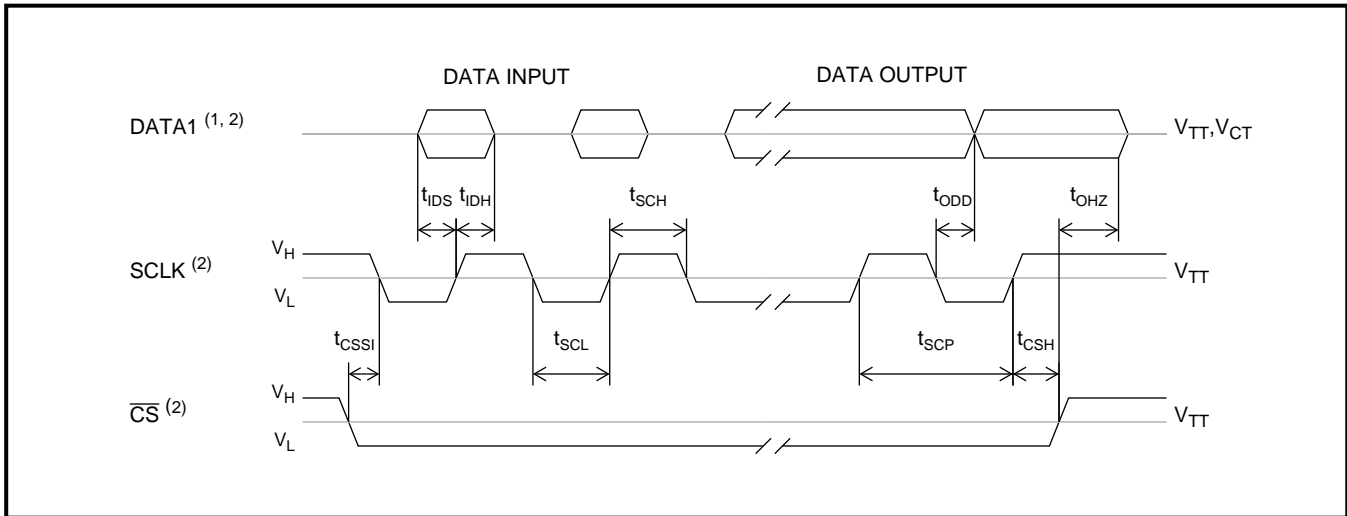

Figure 13 - INTEL Serial Microport Timing

- Notes: 1. CMOS output
 2. TTL input compatible
 3. CMOS input
 (see Table 8 for symbol definitions)

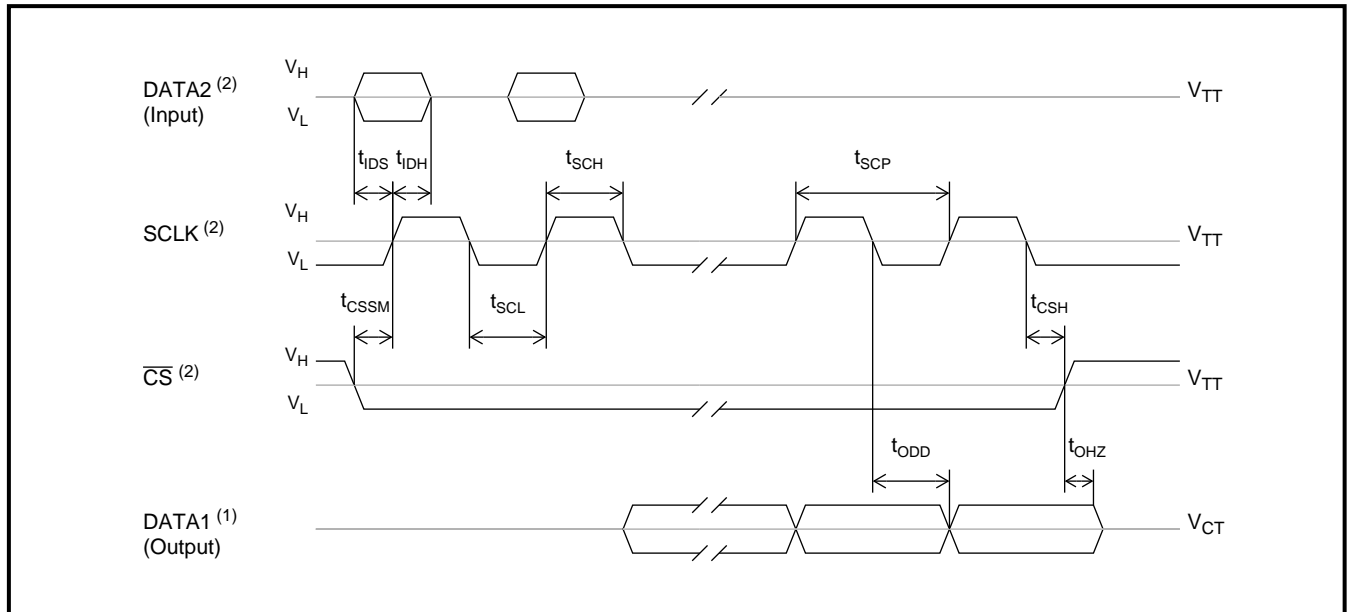

Figure 14 - Motorola Serial Microport Timing

- Notes: 1. CMOS output
 2. TTL input compatible
 3. CMOS input
 (see Table 8 for symbol definitions)

Register Summary

Address: 00h R/W	Main Control Register (MC)									
Power Up Reset 00h	7	6	5	4	3	2	1	0		
	MSB	LIMIT	MUTE_R	MUTE_S	BYPASS	NB-	AGC-	AH-	RESET	LSB
RESET	When high, the power initialization routine is executed presetting all registers to default values. This bit automatically clears itself to '0' when reset is complete.									
AH-	When high, the Howling detector is disabled and when low the Howling detector is enabled.									
AGC-	When high, AGC is disabled and when low AGC is enabled									
NB-	When high, Narrowband signal detectors in Rin and Sin paths are disabled and when low the signal detectors are enabled									
BYPASS	When high, the Send and Receive paths are transparently by-passed from input to output and when low the Send and Receive paths are not bypassed									
MUTE_S	When high, the Sin path is muted to quite code (after the NLP) and when low the Sin path is not muted									
MUTE_R	When high, the Rin path is muted to quite code (after the NLP) and when low the Rin path is not muted									
LIMIT	When high, the 2-bit shift mode is enabled in conjunction with bit 7 of LEC register and when low 2-bit shift mode is disabled									

Address: 21h R/W	Acoustic Echo Canceller Control Register (AEC)									
Power Up Reset 00h	7	6	5	4	3	2	1	0		
	MSB	P-	ASC-	NLP-	INJ-	HPF-	HCLR	ADAPT-	ECBY	LSB
ECBY	When high, the Echo estimate from the filter is not subtracted from the Send path, when low the estimate is subtracted									
ADAPT-	When high, the Echo canceller adaptation is disabled and when low the adaptation is enabled									
HCLR	When high, Adaptive filter coefficients are cleared and when low the filter coefficients are not cleared									
HPF-	When high, Offset nulling filter is bypassed in the Sin/Sout path and when low the Offset nulling filter in not bypassed									
INJ-	When high, the Noise filtering process is disabled in the NLP and when low the Noise filtering process is enabled									
NLP-	When high, the Non Linear Processor is disabled in the Sin/Sout path and when low the NLP is enabled									
ASC-	When high, the Internal Adaptation speed control is disabled and when low the Adaptation speed is enabled									
P-	When high, the Exponential weighting function for the adaptive filter is disabled and when low the weighting function is enabled									

Address: 01h R/W	Line Echo Canceller Control Register (LEC)									
Power Up Reset 00h	7	6	5	4	3	2	1	0		
	MSB	SHFT	ASC-	NLP-	INJ-	HPF-	HCLR	ADAPT-	ECBY	LSB
ECBY	When high, the Echo estimate from the filter is not subtracted from the Send path, when low the estimate is subtracted									
ADAPT-	When high, the Echo canceller adaptation is disabled and when low the adaptation is enabled									
HCLR	When high, Adaptive filter coefficients are cleared and when low the filter coefficients are not cleared									
HPF-	When high, Offset nulling filter is bypassed in the Rin/Rout path and when low the Offset nulling filter in not bypassed									
INJ-	When high, the Noise filtering process is disabled in the NLP and when low the Noise filtering process is enabled									
NLP-	When high, the Non Linear Processor is disabled in the Rin/Rout path and when low the NLP is enabled									
ASC-	When high, the Internal Adaptation speed control is disabled and when low the Adaptation speed is enabled									
SHFT	when high the 16-bit linear mode, inputs Sin, Rin, are shift right by 2 and outputs Sout, Rout are shift left by 2. This bit is ignored when 16-bit linear mode is not selected in both ports. This bit is also ignored if bit 7 of MC register is set to zero									

Address: 22h Read	Acoustic Echo Canceller Status Register (ASR) (* Do not write to this register)																
Power Up Reset 00h	7	-	6	ACMUND	5	HWLNG	4	-	3	NLPDC	2	DT	1	NB	0	NBS	LSB
NBS	When high, the Narrowband signal has been detected in the Sin/Sout path and when low, the Narrowband signal has not been detected in the Sin/Sout path																
NB	LOGICAL OR of the status bit NBS + NBR from LSR Register																
DT	When high the Double Talk is detected and when low, the Double talk is not detected																
NLPDC	When high, the NLP is activated and when low the NLP is not activated																
-	RESERVED.																
HWLNG	When high, Howling is occurring in the loop and when low, no Howling is detected																
ACMUND	When high, No active signal in the Rin/Rout path																
-	RESERVED.																

Address: 02h Read	Line Echo Canceller Status Register (LSR) (* Do not write to this register)																
Power Up Reset 00h	7	-	6	-	5	-	4	-	3	NLPC	2	DT	1	NB	0	NBR	LSB
NBR	When high, a narrowband signal has been detected in the Receive (Rin) path. When low no narrowband signal is not detected in the Rin path																
NB	This bit indicates a LOGICAL-OR of Status bits NBR + NBS (from ASR Register)																
DT	When high, double-talk is detected and when low double-talk is not detected																
NLPC	When high, NLP is activated and when low NLP is not activated																
-	RESERVED.																
-	RESERVED.																
-	RESERVED.																
-	RESERVED.																

Address: 20h R/W	Receive Gain Control Register (RGC)																
Power Up Reset 6Dh	7	-	6	-	5	-	4	-	3	G3	2	G2	1	G1	0	G0	LSB
G0	User Gain Control on the Rin/Rout path (Tolerance of gains: +/- 0.15 dB). The hexadecimal number represents G3 to G0 value in the table below.																
G1																	
G2																	
G3																	
-	RESERVED																
-	RESERVED																
-	RESERVED																
-	RESERVED																

Gain Values for Receive Gain Control Register Bit G3 to G0 (RGC)

0h	-24dB	4h	-12dB	8h	0 dB	Ch	+12 dB
1h	-21dB	5h	-9 dB	9h	+ 3 dB	Dh	+ 15 dB
2h	-18dB	6h	-6 dB	Ah	+ 6 dB	Eh	+ 18 dB
3h	-15dB	7h	-3 dB	Bh	+9 dB	Fh	+ 21 dB

Address: 16h Read	Receive (Rin) Peak Detect Register 1 (RIPD1)								
Power Up Reset 00h	7	6	5	4	3	2	1	0	LSB
RIPD ₀	RIPD ₇	RIPD ₆	RIPD ₅	RIPD ₄	RIPD ₃	RIPD ₂	RIPD ₁	RIPD ₀	
RIPD ₁	These peak detector registers allow the user to monitor the receive in signal (Rin) peak level at reference point R1 (see Figure #1). The information is in 16-bit 2's complement linear coded format presented in two 8 bit registers. The high byte is in Register 2 and the low byte is in Register 1.								
RIPD ₂									
RIPD ₃									
RIPD ₄									
RIPD ₅									
RIPD ₆									
RIPD ₇									

Address: 17h Read	Receive (Rin) Peak Detect Register 2 (RIPD2)								
Power Up Reset 00h	7	6	5	4	3	2	1	0	LSB
RIPD ₈	RIPD ₁₅	RIPD ₁₄	RIPD ₁₃	RIPD ₁₂	RIPD ₁₁	RIPD ₁₀	RIPD ₉	RIPD ₈	
RIPD ₉	See Above Description								
RIPD ₁₀									
RIPD ₁₁									
RIPD ₁₂									
RIPD ₁₃									
RIPD ₁₄									
RIPD ₁₅									

Address: 18h Read	Receive (Rin) ERROR Peak Detect Register 1 (REPD1)								
Power Up Reset 00h	7	6	5	4	3	2	1	0	LSB
REPD ₀	REPD ₇	REPD ₆	REPD ₅	REPD ₄	REPD ₃	REPD ₂	REPD ₁	REPD ₀	
REPD ₁	These peak detector registers allow the user to monitor the error signal peak level at reference point R2 (see Figure #1). The information is in 16-bit 2's complement linear coded format presented in two 8 bit registers. The high byte is in Register 2 and the low byte is in Register 1.								
REPD ₂									
REPD ₃									
REPD ₄									
REPD ₅									
REPD ₆									
REPD ₇									

Address: 19h Read	Receive (Rin) ERROR Peak Detect Register 2 (REPD2)																
Power Up Reset 00h	7	REPD ₁₅	6	REPD ₁₄	5	REPD ₁₃	4	REPD ₁₂	3	REPD ₁₁	2	REPD ₁₀	1	REPD ₉	0	REPD ₈	LSB
REPD8	See above description																
REPD9																	
REPD10																	
REPD11																	
REPD12																	
REPD13																	
REPD14																	
REPD15																	

Address: 3Ah Read	Receive (Rout) Peak Detect Register 1 (ROPD1)																
Power Up Reset 00h	7	ROPD ₇	6	ROPD ₆	5	ROPD ₅	4	ROPD ₄	3	ROPD ₃	2	ROPD ₂	1	ROPD ₁	0	ROPD ₀	LSB
ROPD ₀	These peak detector registers allow the user to monitor the receive out signal (Rout) peak level at reference point R3 (see Figure #1). The information is in 16-bit 2's complement linear coded format presented in two 8 bit registers. The high byte is in Register 2 and the low byte is in Register 1.																
ROPD ₁																	
ROPD ₂																	
ROPD ₃																	
ROPD ₄																	
ROPD ₅																	
ROPD ₆																	
ROPD ₇																	

Address: 3Bh Read	Receive (Rout) Peak Detect Register 2 (ROPD2)																
Power Up Reset 00h	7	ROPD ₁₅	6	ROPD ₁₄	5	ROPD ₁₃	4	ROPD ₁₂	3	ROPD ₁₁	2	ROPD ₁₀	1	ROPD ₉	0	ROPD ₈	LSB
ROPD ₈	See Above description																
ROPD ₉																	
ROPD ₁₀																	
ROPD ₁₁																	
ROPD ₁₂																	
ROPD ₁₃																	
ROPD ₁₄																	
ROPD ₁₅																	

Address: 36h Read	Send (Sin) Peak Detect Register 1 (SIPD1)																
Power Up Reset 00h	7	SIPD ₇	6	SIPD ₆	5	SIPD ₅	4	SIPD ₄	3	SIPD ₃	2	SIPD ₂	1	SIPD ₁	0	SIPD ₀	LSB
SIPD ₀	These peak detector registers allow the user to monitor the receive in signal (Sin) peak level at reference point S1 (see Figure #1). The information is in 16-bit 2's complement linear coded format presented in two 8 bit registers. The high byte is in Register 2 and the low byte is in Register 1.																
SIPD ₁																	
SIPD ₂																	
SIPD ₃																	
SIPD ₄																	
SIPD ₅																	
SIPD ₆																	
SIPD ₇																	

Address: 37h Read	Send (Sin) Peak Detect Register 2 (SIPD2)																
Power Up Reset 00h	7	SIPD ₁₅	6	SIPD ₁₄	5	SIPD ₁₃	4	SIPD ₁₂	3	SIPD ₁₁	2	SIPD ₁₀	1	SIPD ₉	0	SIPD ₈	LSB
SIPD ₈	See above description																
SIPD ₉																	
SIPD ₁₀																	
SIPD ₁₁																	
SIPD ₁₂																	
SIPD ₁₃																	
SIPD ₁₄																	
SIPD ₁₅																	

Address: 38h Read	Send ERROR Peak Detect Register 1 (SEPD1)																
Power Up Reset 00h	7	SEPD ₇	6	SEPD ₆	5	SEPD ₅	4	SEPD ₄	3	SEPD ₃	2	SEPD ₂	1	SEPD ₁	0	SEPD ₀	LSB
SEPD ₀	These peak detector registers allow the user to monitor the error signal peak level in the send path at reference point S2 (see Figure #1). The information is in 16-bit 2's complement linear coded format presented in two 8 bit registers. The high byte is in Register 2 and the low byte is in Register 1.																
SEPD ₁																	
SEPD ₂																	
SEPD ₃																	
SEPD ₄																	
SEPD ₅																	
SEPD ₆																	
SEPD ₇																	

Address: 39h Read	Send ERROR Peak Detect Register 2 (SEPD2)																	
Power Up Reset 00h	MSB	7	SEPD ₁₅	6	SEPD ₁₄	5	SEPD ₁₃	4	SEPD ₁₂	3	SEPD ₁₁	2	SEPD ₁₀	1	SEPD ₉	0	SEPD ₈	LSB
SEPD8	See Above description																	
SEPD9																		
SEPD10																		
SEPD11																		
SEPD12																		
SEPD13																		
SEPD14																		
SEPD15																		

Address: 1Ah Read	Send (Sout) Peak Detect Register 1 (SOPD1)																	
Power Up Reset 00h	MSB	7	SOPD ₇	6	SOPD ₆	5	SOPD ₅	4	SOPD ₄	3	SOPD ₃	2	SOPD ₂	1	SOPD ₁	0	SOPD ₀	LSB
SOPD ₀	These peak detector registers allow the user to monitor the Send out signal (Sout) peak level at reference point S3 (see Figure #1). The information is in 16-bit 2's complement linear coded format presented in two 8 bit registers. The high byte is in Register 2 and the low byte is in Register 1.																	
SOPD ₁																		
SOPD ₂																		
SOPD ₃																		
SOPD ₄																		
SOPD ₅																		
SOPD ₆																		
SOPD ₇																		

Address: 1Bh Read	Send (Sout) Peak Detect Register 2 (SOPD2)																	
Power Up Reset 00h	MSB	7	SOPD ₁₅	6	SOPD ₁₄	5	SOPD ₁₃	4	SOPD ₁₂	3	SOPD ₁₁	2	SOPD ₁₀	1	SOPD ₉	0	SOPD ₈	LSB
SOPD ₈	See Above description																	
SOPD ₉																		
SOPD ₁₀																		
SOPD ₁₁																		
SOPD ₁₂																		
SOPD ₁₃																		
SOPD ₁₄																		
SOPD ₁₅																		

Address: 3Ch R/W	Acoustic Echo Canceller Adaptation Speed Register 1 (A_AS1)								
Power Up Reset 00h	7	6	5	4	3	2	1	0	LSB
A_AS ₀	A_AS ₇	A_AS ₆	A_AS ₅	A_AS ₄	A_AS ₃	A_AS ₂	A_AS ₁	A_AS ₀	
A_AS ₁	This register allows the user to program control the adaptation speed of the Acoustic Echo Canceller. This register value changes dynamically when the 'ASC-' bit in the Acoustic Echo Canceller Control Register is low. The 'ASC-' bit must be 1 when this register is under user control. The valid range is from 0000h to 7FFFh. The high byte is in Register 2 and the low byte is in Register 1. Smaller values correspond to slower adaptation speed.								
A_AS ₂									
A_AS ₃									
A_AS ₄									
A_AS ₅									
A_AS ₆									
A_AS ₇									

Address: 3Dh R/W	Acoustic Echo Canceller Adaptation Speed Register 2 (A_AS2)								
Power Up Reset 10h	7	6	5	4	3	2	1	0	LSB
A_AS ₈	A_AS ₁₅	A_AS ₁₄	A_AS ₁₃	A_AS ₁₂	A_AS ₁₁	A_AS ₁₀	A_AS ₉	A_AS ₈	
A_AS ₉	See Above description								
A_AS ₁₀									
A_AS ₁₁									
A_AS ₁₂									
A_AS ₁₃									
A_AS ₁₄									
A_AS ₁₅									

Address: 1Ch R/W	Line Echo Canceller Adaptation Speed Register 1 (L_AS1)								
Power Up Reset 00h	7	6	5	4	3	2	1	0	LSB
L_AS ₀	L_AS ₇	L_AS ₆	L_AS ₅	L_AS ₄	L_AS ₃	L_AS ₂	L_AS ₁	L_AS ₀	
L_AS ₁	This register allows the user to program control the adaptation speed of the Line Echo Canceller. This register value changes dynamically when the 'ASC-' bit in the Acoustic Echo Canceller Control Register is low. The 'ASC-' bit must be 1 when this register is under user control. The valid range is from 0000h to 7FFFh. The high byte is in Register 2 and the low byte is in Register 1. Smaller values correspond to slower adaptation speed.								
L_AS ₂									
L_AS ₃									
L_AS ₄									
L_AS ₅									
L_AS ₆									
L_AS ₇									

Address: 1Dh R/W	Line Echo Canceller Adaptation Speed Register 2 (L_AS2)																
Power Up Reset 08h	7	L_AS15	6	L_AS14	5	L_AS13	4	L_AS12	3	L_AS11	2	L_AS10	1	L_AS9	0	L_AS8	LSB
L_AS8	See Above description																
L_AS9																	
L_AS10																	
L_AS11																	
L_AS12																	
L_AS13																	
L_AS14																	
L_AS15																	

Address: 24h R/W	Rout Limiter Register 1 (RL1)																
Power Up Reset 80h	7	L ₀	6	-	5	-	4	-	3	-	2	-	1	-	0	-	LSB
-	RESERVED																
-																	
-																	
-																	
-																	
-																	
-																	
L ₀	This bit is used in conjunction with Rout Limiter Register 2. (See description below.)																

Address: 25h R/W	Rout Limiter Register 2 (RL2)																
Power Up Reset 3Eh	7	L ₈	6	L ₇	5	L ₆	4	L ₅	3	L ₄	2	L ₃	1	L ₂	0	L ₁	LSB
L ₁	<p>In conjunction with bit 7 (L₀) of the above (RL1) register, this register (RL2) allows the user to program the output Limiter threshold value in the Rout path.</p> <p>Default value is (1f40)h which is equal to 3.14dBmo Maximum value is (7FC0)h = 15 dBmo Minimum value is (0040)h = -38 dBmo</p>																
L ₂																	
L ₃																	
L ₄																	
L ₅																	
L ₆																	
L ₇																	
L ₈																	

Address: 26h R/W	Sout Limiter Register (SL)																
Power Up Reset 3Dh	7	L ₄	6	L ₃	5	L ₂	4	L ₁	3	L ₀	2	-	1	-	0	-	LSB
-	RESERVED																
L ₀	This register allows the user to program the output Limiter threshold value in the Rout path																
L ₁	Default value is (1f40)h which is equal to 3.14dBmo																
L ₂	Maximum value is (7F40)h																
L ₃																	
L ₄																	

Address: 03h Read	Device Revision Code Register (DRC)																
Power Up Reset 40h	7	DRC ₂	6	DRC ₁	5	DRC ₀	4	-	3	-	2	-	1	-	0	-	LSB
-	RESERVED																
DRC ₀	Revision code of the device (=02).																
DRC ₁																	
DRC ₂																	

Package Outlines

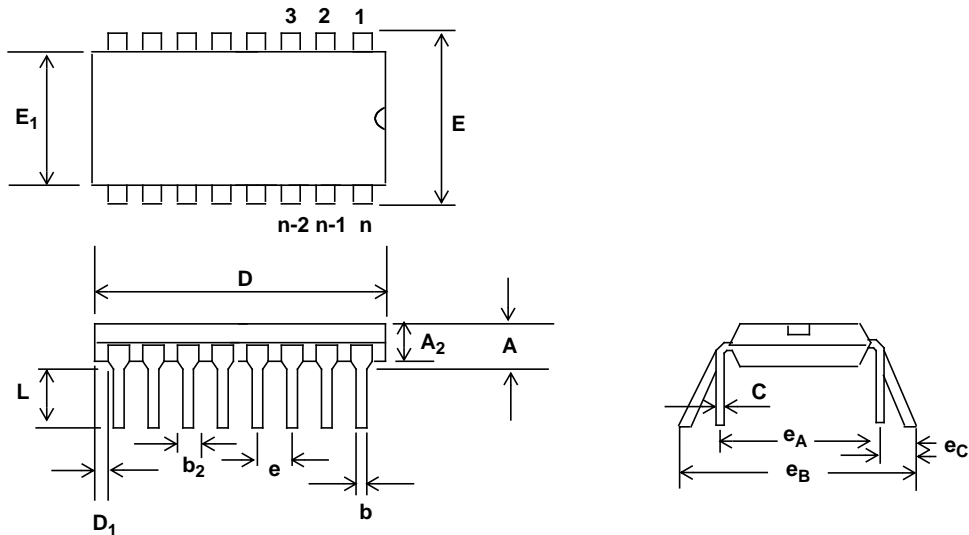

Notes:

- 1) Not to scale
- 2) Dimensions in inches
- 3) (Dimensions in millimeters)

Plastic Dual-In-Line Packages (PDIP) - E Suffix

DIM	8-Pin		16-Pin		18-Pin		20-Pin	
	Plastic		Plastic		Plastic		Plastic	
	Min	Max	Min	Max	Min	Max	Min	Max
A		0.210 (5.33)		0.210 (5.33)		0.210 (5.33)		0.210 (5.33)
A₂	0.115 (2.92)	0.195 (4.95)	0.115 (2.92)	0.195 (4.95)	0.115 (2.92)	0.195 (4.95)	0.115 (2.92)	0.195 (4.95)
b	0.014 (0.356)	0.022 (0.558)	0.014 (0.356)	0.022 (0.558)	0.014 (0.356)	0.022 (0.558)	0.014 (0.356)	0.022 (0.558)
b₂	0.045 (1.14)	0.070 (1.77)	0.045 (1.14)	0.070 (1.77)	0.045 (1.14)	0.070 (1.77)	0.045 (1.14)	0.070 (1.77)
C	0.008 (0.203)	0.014 (0.356)	0.008 (0.203)	0.014 (0.356)	0.008 (0.203)	0.014 (0.356)	0.008 (0.203)	0.014 (0.356)
D	0.355 (9.02)	0.400 (10.16)	0.780 (19.81)	0.800 (20.32)	0.880 (22.35)	0.920 (23.37)	0.980 (24.89)	1.060 (26.9)
D₁	0.005 (0.13)		0.005 (0.13)		0.005 (0.13)		0.005 (0.13)	
E	0.300 (7.62)	0.325 (8.26)	0.300 (7.62)	0.325 (8.26)	0.300 (7.62)	0.325 (8.26)	0.300 (7.62)	0.325 (8.26)
E₁	0.240 (6.10)	0.280 (7.11)	0.240 (6.10)	0.280 (7.11)	0.240 (6.10)	0.280 (7.11)	0.240 (6.10)	0.280 (7.11)
e	0.100 BSC (2.54)		0.100 BSC (2.54)		0.100 BSC (2.54)		0.100 BSC (2.54)	
e_A	0.300 BSC (7.62)		0.300 BSC (7.62)		0.300 BSC (7.62)		0.300 BSC (7.62)	
L	0.115 (2.92)	0.150 (3.81)	0.115 (2.92)	0.150 (3.81)	0.115 (2.92)	0.150 (3.81)	0.115 (2.92)	0.150 (3.81)
e_B		0.430 (10.92)		0.430 (10.92)		0.430 (10.92)		0.430 (10.92)
e_C	0	0.060 (1.52)	0	0.060 (1.52)	0	0.060 (1.52)	0	0.060 (1.52)

NOTE: Controlling dimensions in parenthesis () are in millimeters.

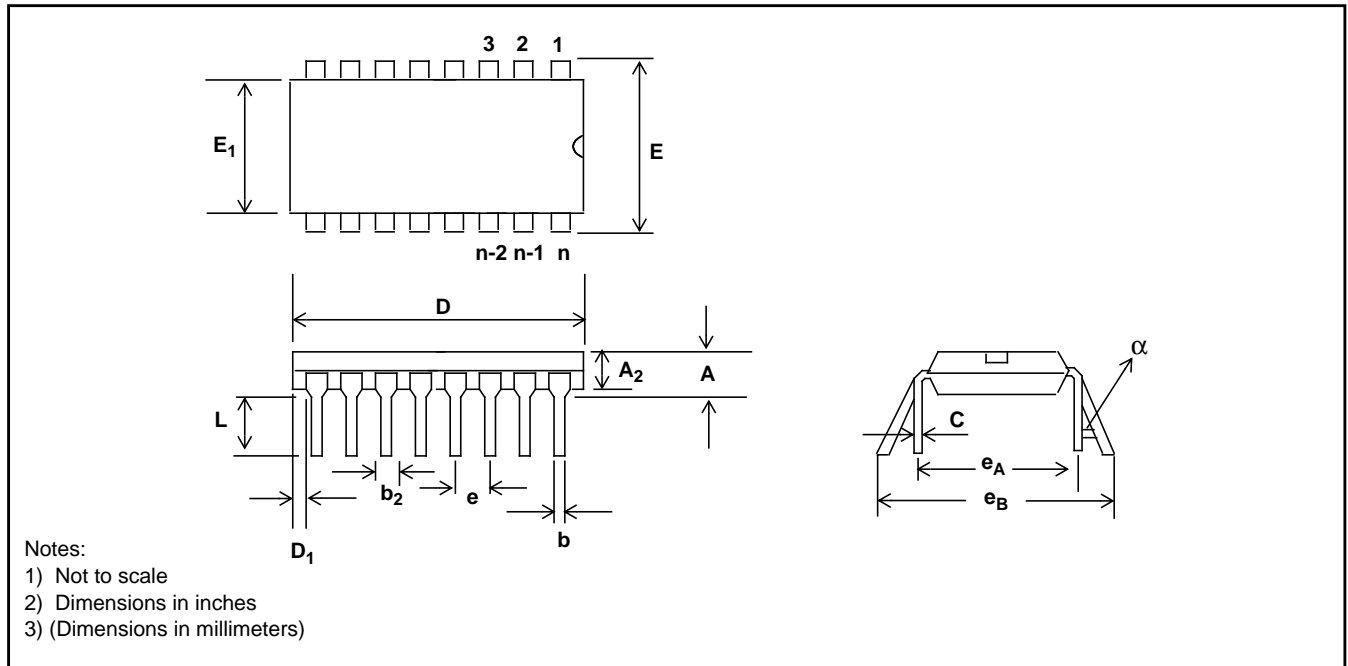

Plastic Dual-In-Line Packages (PDIP) - E Suffix

DIM	22-Pin		24-Pin		28-Pin		40-Pin	
	Plastic		Plastic		Plastic		Plastic	
	Min	Max	Min	Max	Min	Max	Min	Max
A		0.210 (5.33)		0.250 (6.35)		0.250 (6.35)		0.250 (6.35)
A₂	0.125 (3.18)	0.195 (4.95)	0.125 (3.18)	0.195 (4.95)	0.125 (3.18)	0.195 (4.95)	0.125 (3.18)	0.195 (4.95)
b	0.014 (0.356)	0.022 (0.558)	0.014 (0.356)	0.022 (0.558)	0.014 (0.356)	0.022 (0.558)	0.014 (0.356)	0.022 (0.558)
b₂	0.045 (1.15)	0.070 (1.77)	0.030 (0.77)	0.070 (1.77)	0.030 (0.77)	0.070 (1.77)	0.030 (0.77)	0.070 (1.77)
C	0.008 (0.204)	0.015 (0.381)	0.008 (0.204)	0.015 (0.381)	0.008 (0.204)	0.015 (0.381)	0.008 (0.204)	0.015 (0.381)
D	1.050 (26.67)	1.120 (28.44)	1.150 (29.3)	1.290 (32.7)	1.380 (35.1)	1.565 (39.7)	1.980 (50.3)	2.095 (53.2)
D₁	0.005 (0.13)		0.005 (0.13)		0.005 (0.13)		0.005 (0.13)	
E	0.390 (9.91)	0.430 (10.92)	0.600 (15.24)	0.670 (17.02)	0.600 (15.24)	0.670 (17.02)	0.600 (15.24)	0.670 (17.02)
E			0.290 (7.37)	.330 (8.38)				
E₁	0.330 (8.39)	0.380 (9.65)	0.485 (12.32)	0.580 (14.73)	0.485 (12.32)	0.580 (14.73)	0.485 (12.32)	0.580 (14.73)
E₁			0.246 (6.25)	0.254 (6.45)				
e	0.100 BSC (2.54)		0.100 BSC (2.54)		0.100 BSC (2.54)		0.100 BSC (2.54)	
e_A	0.400 BSC (10.16)		0.600 BSC (15.24)		0.600 BSC (15.24)		0.600 BSC (15.24)	
e_A			0.300 BSC (7.62)					
e_B				0.430 (10.92)				
L	0.115 (2.93)	0.160 (4.06)	0.115 (2.93)	0.200 (5.08)	0.115 (2.93)	0.200 (5.08)	0.115 (2.93)	0.200 (5.08)
α		15°		15°		15°		15°

Shaded areas for 300 Mil Body Width 24 PDIP only

Package Outlines

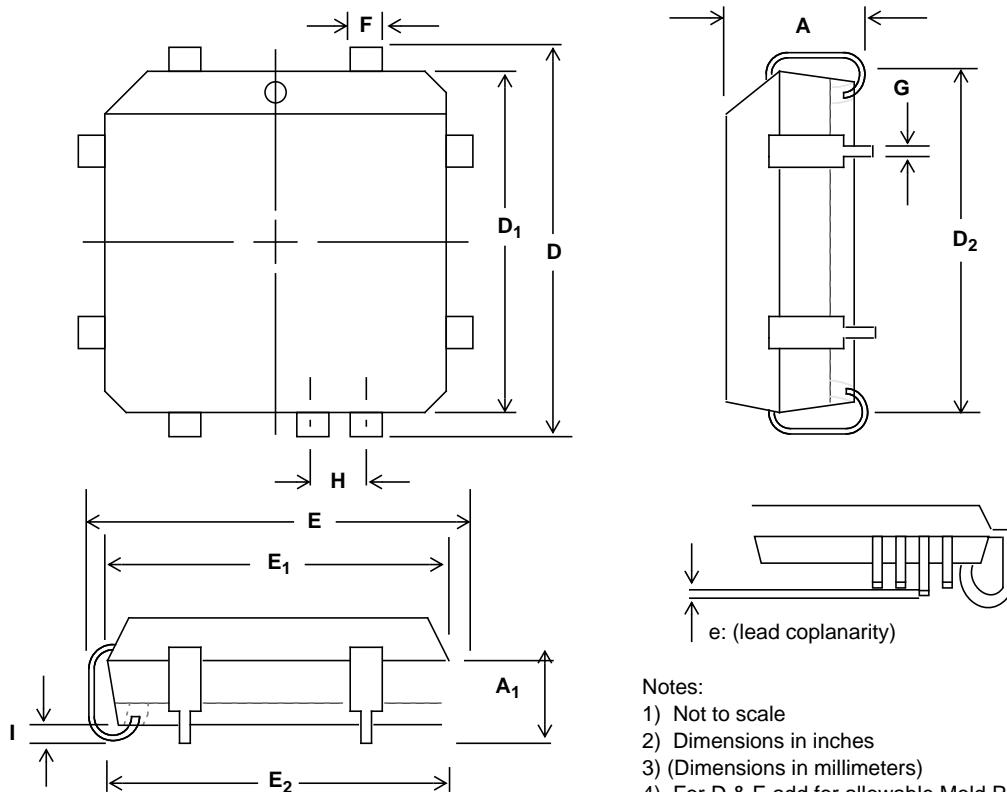

- Notes:
- 1) Not to scale
 - 2) Dimensions in inches
 - 3) (Dimensions in millimeters)
 - 4) For D & E add for allowable Mold Protrusion 0.010"

Dim	20-Pin		28-Pin		44-Pin		68-Pin		84-Pin	
	Min	Max	Min	Max	Min	Max	Min	Max	Min	Max
A	0.165 (4.20)	0.180 (4.57)	0.165 (4.20)	0.180 (4.57)	0.165 (4.20)	0.180 (4.57)	0.165 (4.20)	0.200 (5.08)	0.165 (4.20)	0.200 (5.08)
A₁	0.090 (2.29)	0.120 (3.04)	0.090 (2.29)	0.120 (3.04)	0.090 (2.29)	0.120 (3.04)	0.090 (2.29)	0.130 (3.30)	0.090 (2.29)	0.130 (3.30)
D/E	0.385 (9.78)	0.395 (10.03)	0.485 (12.32)	0.495 (12.57)	0.685 (17.40)	0.695 (17.65)	0.985 (25.02)	0.995 (25.27)	1.185 (30.10)	1.195 (30.35)
D₁/E₁	0.350 (8.890)	0.356 (9.042)	0.450 (11.430)	0.456 (11.582)	0.650 (16.510)	0.656 (16.662)	0.950 (24.130)	0.958 (24.333)	1.150 (29.210)	1.158 (29.413)
D₂/E₂	0.290 (7.37)	0.330 (8.38)	0.390 (9.91)	0.430 (10.92)	0.590 (14.99)	0.630 (16.00)	0.890 (22.61)	0.930 (23.62)	1.090 (27.69)	1.130 (28.70)
e	0	0.004	0	0.004	0	0.004	0	0.004	0	0.004
F	0.026 (0.661)	0.032 (0.812)	0.026 (0.661)	0.032 (0.812)	0.026 (0.661)	0.032 (0.812)	0.026 (0.661)	0.032 (0.812)	0.026 (0.661)	0.032 (0.812)
G	0.013 (0.331)	0.021 (0.533)	0.013 (0.331)	0.021 (0.533)	0.013 (0.331)	0.021 (0.533)	0.013 (0.331)	0.021 (0.533)	0.013 (0.331)	0.021 (0.533)
H	0.050 BSC (1.27 BSC)		0.050 BSC (1.27 BSC)		0.050 BSC (1.27 BSC)		0.050 BSC (1.27 BSC)		0.050 BSC (1.27 BSC)	
I	0.020 (0.51)		0.020 (0.51)		0.020 (0.51)		0.020 (0.51)		0.020 (0.51)	

Plastic J-Lead Chip Carrier - P-Suffix



**For more information about all Zarlink products
visit our Web Site at
www.zarlink.com**

Information relating to products and services furnished herein by Zarlink Semiconductor Inc. or its subsidiaries (collectively "Zarlink") is believed to be reliable. However, Zarlink assumes no liability for errors that may appear in this publication, or for liability otherwise arising from the application or use of any such information, product or service or for any infringement of patents or other intellectual property rights owned by third parties which may result from such application or use. Neither the supply of such information or purchase of product or service conveys any license, either express or implied, under patents or other intellectual property rights owned by Zarlink or licensed from third parties by Zarlink, whatsoever. Purchasers of products are also hereby notified that the use of product in certain ways or in combination with Zarlink, or non-Zarlink furnished goods or services may infringe patents or other intellectual property rights owned by Zarlink.

This publication is issued to provide information only and (unless agreed by Zarlink in writing) may not be used, applied or reproduced for any purpose nor form part of any order or contract nor to be regarded as a representation relating to the products or services concerned. The products, their specifications, services and other information appearing in this publication are subject to change by Zarlink without notice. No warranty or guarantee express or implied is made regarding the capability, performance or suitability of any product or service. Information concerning possible methods of use is provided as a guide only and does not constitute any guarantee that such methods of use will be satisfactory in a specific piece of equipment. It is the user's responsibility to fully determine the performance and suitability of any equipment using such information and to ensure that any publication or data used is up to date and has not been superseded. Manufacturing does not necessarily include testing of all functions or parameters. These products are not suitable for use in any medical products whose failure to perform may result in significant injury or death to the user. All products and materials are sold and services provided subject to Zarlink's conditions of sale which are available on request.

Purchase of Zarlink's I²C components conveys a licence under the Philips I²C Patent rights to use these components in and I²C System, provided that the system conforms to the I²C Standard Specification as defined by Philips.

Zarlink, ZL and the Zarlink Semiconductor logo are trademarks of Zarlink Semiconductor Inc.

Copyright Zarlink Semiconductor Inc. All Rights Reserved.

TECHNICAL DOCUMENTATION - NOT FOR RESALE