

### Features

- Independent multiple channels of echo cancellation; from 32 channels of 64ms to 16 channels of 128ms with the ability to mix channels at 128ms or 64ms in any combination
- Independent Power Down mode for each group of 2 channels for power management
- ITU-T G.165 and G.168 compliant
- Field proven, high quality performance
- Compatible to ST-BUS and GCI interface at 2Mb/s serial PCM
- PCM coding,  $\mu$ A-Law ITU-T G.711 or sign magnitude
- Per channel Fax/Modem G.164 2100Hz or G.165 2100Hz phase reversal Tone Disable
- Per channel echo canceller parameters control
- Transparent data transfer and mute
- Fast reconvergence on echo path changes
- Non-Linear Processor with high quality subjective performance
- Protection against narrow band signal divergence
- Offset nulling of all PCM channels
- 10 MHz or 20 MHz master clock operation
- 3.3 Volts operation with 5-Volt tolerant inputs
- No external memory required
- Non-multiplexed microprocessor interface
- IEEE-1149.1 (JTAG) Test Access Port

DS5385

ISSUE 1

June 2000

### Ordering Information

MT9300BL 160-Pin MQFP  
 MT9300BV 208-Ball LPGA  
**-40°C to +85°C**

### Applications

- Voice over IP network gateways
- Voice over ATM, Frame Relay
- T1/E1/J1 multichannel echo cancellation
- Wireless base stations
- Echo Canceller pools
- DCME, satellite and multiplexer systems

### Description

The MT9300B Voice Echo Canceller implements a cost effective solution for telephony voice-band echo cancellation conforming to ITU-T G.168 requirements. The MT9300B architecture contains 16 groups of two echo cancellers (ECA and ECB) which can be configured to provide two channels of 64 milliseconds or one channel of 128 milliseconds echo cancellation. This provides 32 channels of 64 milliseconds to 16 channels of 128 milliseconds echo cancellation or any combination of the two configurations. The MT9300B supports ITU-T G.165 and G.164 tone disable requirements.

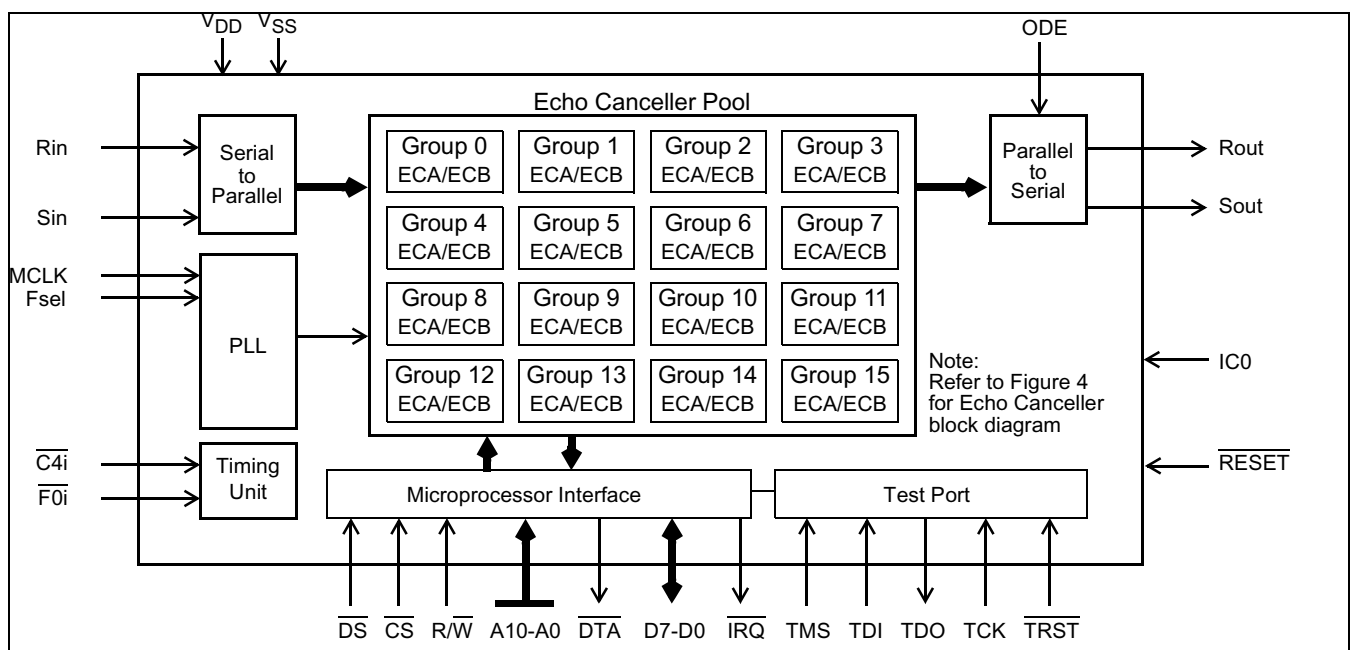

Figure 1 - Functional Block Diagram

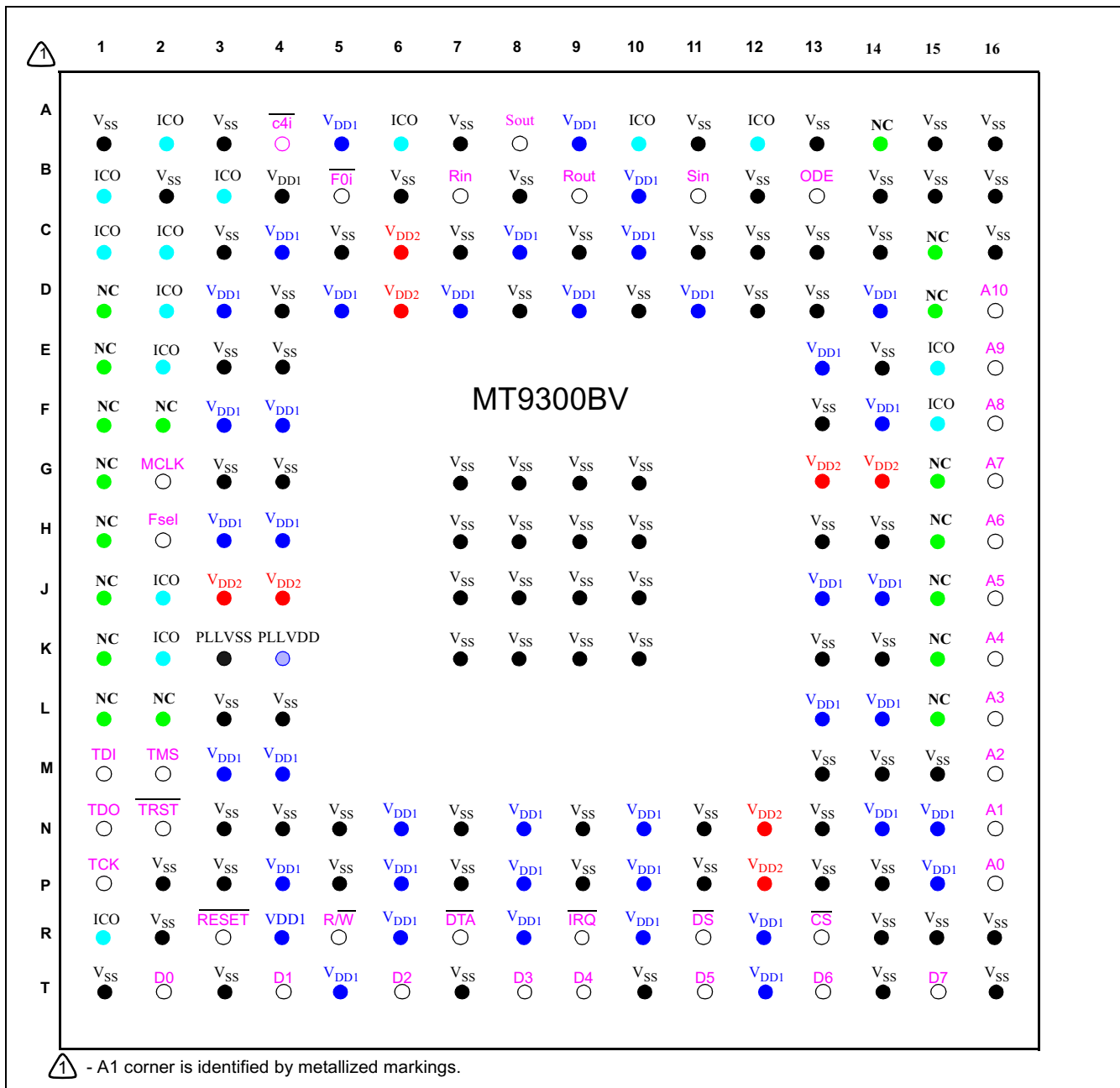

Figure 2 - 208 Ball LBG

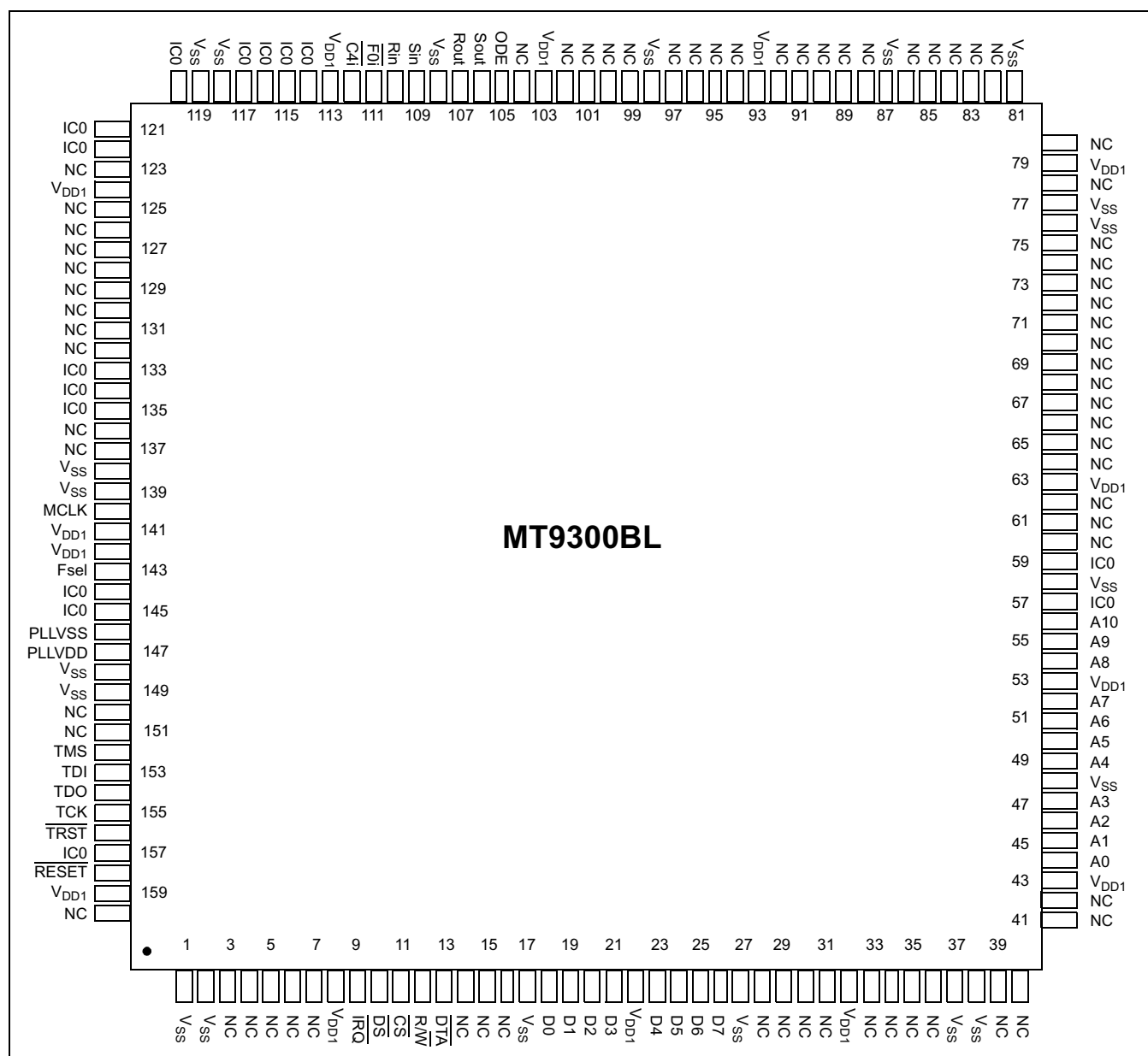

Figure 3 - 160 Pin MQFP

Pin Description

Pin #		Name	Description
208-Ball LBGA	160 Pin MQFP		
A1,A3,A7,A11,A13,A15, A16, B2, B6,B8,B12, B14, B15, B16,C3,C5,C7, C9,C11,C12, C13,C14, C16, D4,D8,D10, D12,D13,E3, E4,E14,F13,G3, G4,G7,G8,G9,G10,H7,H8,H9, H10,H13, H14,J7,J8,J9, J10, K7,K8, K9,K10,K13, K14,L3, L4,M13, M14,,M15,N3,N4,N5, N7,N9,N11,N13,P2,P3,P5,P7,P9.P 11,P13, P14,R2,R14, R15,R16,T1, T3,T7,T10, T14,T16	1, 2, 17, 27, 37, 38, 48, 58, 76, 77, 81, 87, 98, 108, 118, 119, 138, 139, 148, 149	V <sub>SS</sub>	Ground.

## Pin Description (continued)

Pin #		Name	Description
208-Ball LBGA	160 Pin MQFP		
A5,A9,B4,B10,C4,C8,C10,D3,D5, D7,D9,D11,D14,E13, F3,F4,F14,H3,H4,J13,J14,L13,L14 ,M3,M4,N6,N8, N10,N14, N15,P4,P6,P8, P10,P15, R4,R6,R8,R10, R12,T5,T12	8, 22, 32, 43, 53, 63, 79, 93, 103, 113, 124, 141, 142, 159	V <sub>DD1</sub>	<b>Positive Power Supply.</b> Nominally 3.3 volt.
E15,F15,A12,A10,A6,A2, B1,B3,C1,C2,D2,E2,J2,K2,R1	57, 59, 114, 115, 116,117, 120, 121,122, 133, 134, 135, 144, 145, 157,	IC0	<b>Internal Connection.</b> These pins must be connected to V <sub>SS</sub> for normal operation.
A14,C15,D1,D15,E1,F1, G1, G15,H1,H15,J1,J15,K1, K15,L1,L15,F2,L2	3 to 7, 14 to 16, 28 to 31, 33 to 36, 39 to 42, 60 to 62, 64 to 75, 78, 80, 82 to 86, 88 to 92, 94 to 97, 99 to102, 104, 123, 125 to 132, 136, 137, 150,151,160	NC	<b>No connection.</b> These pins must be left open for normal operation.
R9	9	$\overline{\text{IRQ}}$	<b>Interrupt Request (Open Drain Output).</b> This output goes low when an interrupt occurs in any channel. $\overline{\text{IRQ}}$ returns high when all the interrupts have been read from the Interrupt FIFO Register. A pull-up resistor (1K typical) is required at this output.
R11	10	$\overline{\text{DS}}$	<b>Data Strobe (Input).</b> This active low input works in conjunction with CS to enable the read and write operations.
R13	11	$\overline{\text{CS}}$	<b>Chip Select (Input).</b> This active low input is used by a microprocessor to activate the microprocessor port.
R5	12	$\overline{\text{R/W}}$	<b>Read/Write (Input).</b> This input controls the direction of the data bus lines (D7-D0) during a microprocessor access.
R7	13	$\overline{\text{DTA}}$	<b>Data Transfer Acknowledgment (Open Drain Output).</b> This active low output indicates that a data bus transfer is completed. A pull-up resistor (1K typical) is required at this output.
T2,T4,T6,T8,T9,T11,T13,T15	18, 19, 20, 21, 23, 24, 25, 26	D0 - D3, D4 - D7	<b>Data Bus D0 - D7 (Bidirectional).</b> These pins form the 8-bit bidirectional data bus of the microprocessor port.

## Pin Description (continued)

Pin #		Name	Description
208-Ball LBGA	160 Pin MQFP		
P16,N16,M16,L16,K16, J16,H16,G16,F16,E16, D16	44, 45,46, 47,49, 50, 51,52,54, 55, 56	A0 - A10	<b>Address A0 to A10 (Input).</b> These inputs provide the A10 - A0 address lines to the internal registers.
B13	105	ODE	<b>Output Drive Enable (Input).</b> This input pin is logically AND'd with the ODE bit-6 of the Main Control Register. When both ODE bit and ODE input pin are high, the Rout and Sout ST-BUS outputs are enabled. When the ODE bit is low or the ODE input pin is low, the Rout and Sout ST-BUS outputs are high impedance.
A8	106	Sout	<b>Send PCM Signal Output (Output).</b> Port 1 TDM data output streams. Sout pin outputs serial TDM data streams at 2.048 Mb/s with 32 channels per stream.
B9	107	Rout	<b>Receive PCM Signal Output (Output).</b> Port 2 TDM data output streams. Rout pin outputs serial TDM data streams at 2.048 Mb/s with 32 channels per stream.
B11	109	Sin	<b>Send PCM Signal Input (Input).</b> Port 2 TDM data input streams. Sin pin receives serial TDM data streams at 2.048 Mb/s with 32 channels per stream.
B7	110	Rin	<b>Receive PCM Signal Input (Input).</b> Port 1 TDM data input streams. Rin pin receives serial TDM data streams at 2.048 Mb/s with 32 channels per stream.
B5	111	$\overline{F0i}$	<b>Frame Pulse (Input).</b> This input accepts and automatically identifies frame synchronization signals formatted according to ST-BUS or GCI interface specifications.
A4	112	$\overline{C4i}$	<b>Serial Clock (Input).</b> 4.096 MHz serial clock for shifting data in/out on the serial streams (Rin, Sin, Rout, Sout).
G2	140	MCLK	<b>Master Clock (Input).</b> Nominal 10MHz or 20MHz Master Clock input. May be connected to an asynchronous (relative to frame signal) clock source.
H2	143	Fsel	<b>Frequency select (Input).</b> This input selects the Master Clock frequency operation. When Fsel pin is low, nominal 19.2MHz Master Clock input must be applied. When Fsel pin is high, nominal 9.6MHz Master Clock input must be applied.
K3	146	PLL <sub>VSS</sub>	<b>PLL Ground.</b> Must be connected to V <sub>SS</sub> .
K4	147	PLL <sub>VDD</sub>	<b>PLL Power Supply.</b> Must be connected to V <sub>DD1</sub> .
M2	152	TMS	<b>Test Mode Select (3.3V Input).</b> JTAG signal that controls the state transitions of the TAP controller. This pin is pulled high by an internal pull-up when not driven.
M1	153	TDI	<b>Test Serial Data In (3.3V Input).</b> JTAG serial test instructions and data are shifted in on this pin. This pin is pulled high by an internal pull-up when not driven.

## Pin Description (continued)

Pin #		Name	Description
208-Ball LBGA	160 Pin MQFP		
N1	154	TDO	<b>Test Serial Data Out (Output).</b> JTAG serial data is output on this pin on the falling edge of TCK. This pin is held in high impedance state when JTAG scan is not enabled.
P1	155	TCK	<b>Test Clock (3.3V Input).</b> Provides the clock to the JTAG test logic.
N2	156	$\overline{\text{TRST}}$	<b>Test Reset (3.3V Input).</b> Asynchronously initializes the JTAG TAP controller by putting it in the Test-Logic-Reset state. This pin should be pulsed low on power-up or held low, to ensure that the MT9300B is in the normal functional mode. This pin is pulled by an internal pull-down when not driven.
R3	158	$\overline{\text{RESET}}$	<b>Device Reset (Schmitt Trigger Input).</b> An active low resets the device and puts the MT9300B into a low-power stand-by mode. When the $\overline{\text{RESET}}$ pin is returned to logic high and a clock is applied to the MCLK pin, the device will automatically execute initialization routines, which preset all the Control and Status Registers to their default power-up values.
C6,D6,J3,J4,N12,P12, G13,G14		V <sub>DD2</sub>	These LBGA pins should be wired to V <sub>DD2</sub> = 1.8V for <b>FUTURE USE</b> . If the customer does not intend to use future generation of the device, then these pins should be NO CONNECTS

## Device Overview

The MT9300B architecture contains 32 echo cancellers divided into 16 groups. Each group has two echo cancellers, Echo Cancellor A and Echo Cancellor B. Each group can be configured in Normal, Extended Delay or Back-to-Back configurations. In **Normal configuration**, a group of echo cancellers provides two channels of 64ms echo cancellation, which run independently on different channels. In **Extended Delay** configuration, a group of echo cancellers achieves 128ms of echo cancellation by cascading the two echo cancellers (A & B). In **Back-to-Back** configuration, the two echo cancellers from the same group are positioned to cancel echo coming from both directions in a single channel, providing full-duplex 64ms echo cancellation.

Each echo canceller contains the following main elements (see Figure 4).

- Adaptive Filter for estimating the echo channel
- Subtractor for cancelling the echo
- Double-Talk detector for disabling the filter

adaptation during periods of double-talk

- Path Change detector for fast reconvergence on major echo path changes
- Instability Detector to combat oscillation in very low ERL environments
- Non-Linear Processor for suppression of residual echo
- Disable Tone Detectors for detecting valid disable tones at send and receive path inputs
- Narrow-Band Detector for preventing Adaptive Filter divergence from narrow-band signals
- Offset Null filters for removing the DC component in PCM channels
- 12dB attenuator for signal attenuation
- Parallel controller interface compatible with Motorola microcontrollers
- PCM encoder/decoder compatible with  $\mu$ /A-Law ITU-T G.711 or Sign-Magnitude coding

Each echo canceller in the MT9300B has four functional states: *Mute*, *Bypass*, *Disable Adaptation* and *Enable Adaptation*. These are explained in the section entitled Echo Cancellor Functional States.

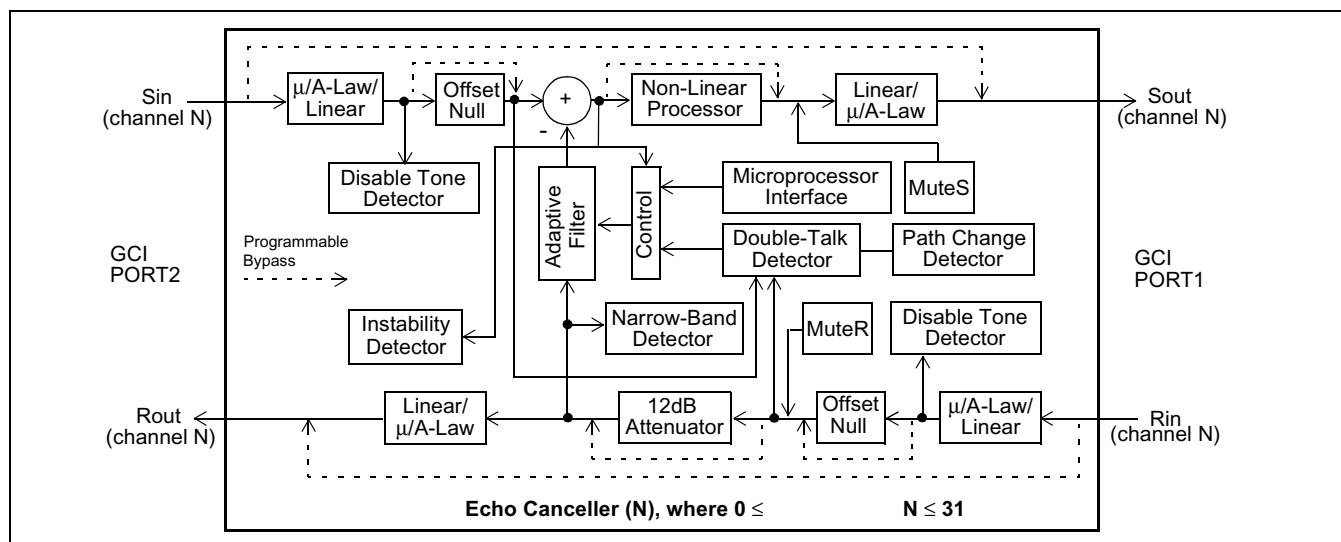

Figure 4 - Echo Canceller Functional Block Diagram

### Adaptive Filter

The adaptive filter adapts to the echo path and generates an estimate of the echo signal. This echo estimate is then subtracted from Sin. For each group of echo cancellers, the adaptive filter is a 1024 tap FIR adaptive filter which is divided into two sections. Each section contains 512 taps providing 64ms of echo estimation. In **Normal configuration**, the first section is dedicated to channel A and the second section to channel B. In **Extended Delay configuration**, both sections are cascaded to provide 128ms of echo estimation in channel A. In **Back-to Back configuration**, the first section is used in the receive direction and the second section is used in the transmit direction for the same channel.

### Double-Talk Detector

Double-Talk is defined as those periods of time when signal energy is present in both directions simultaneously. When this happens, it is necessary to disable the filter adaptation to prevent divergence of the Adaptive Filter coefficients. Note that when double-talk is detected, the adaptation process is halted but the echo canceller continues to cancel echo using the previous converged echo profile.

A double-talk condition exists whenever the relative signal levels of Rin (Lrin) and Sin (Lsin) meet the following condition:

$$L_{sin} > L_{rin} + 20\log_{10}(DTDT)$$

where DTDT is the Double-Talk Detection Threshold. Lsin and Lrin are signal levels expressed in dBm0.

A different method is used when it is uncertain whether Sin consists of a low level double-talk signal or an echo return. During these periods, the adaptation process is slowed down but it is not halted.

In the G.168 standard, the echo return loss is expected to be at least 6dB. This implies that the Double-Talk Detector Threshold (DTDT) should be set to 0.5 (-6dB). However, in order to get additional guardband, the DTDT is set internally to 0.5625 (-5dB).

In some applications the return loss can be higher or lower than 6dB. The MT9300B allows the user to change the detection threshold to suit each application's need. This threshold can be set by writing the desired threshold value into the DTDT register.

The DTDT register is 16 bits wide. The register value in hexadecimal can be calculated with the following equation:

$$DTDT_{(hex)} = hex(DTDT_{(dec)} * 32768)$$

where  $0 < DTDT_{(dec)} < 1$

Example: For DTDT = 0.5625 (-5dB), the hexadecimal value becomes  $hex(0.5625 * 32768) = 4800H$

## Path Change Detector

Integrated into the MT9300B is a Path Change Detector. This permits fast reconvergence when a major change occurs in the echo channel. Subtle changes in the echo channel are also tracked automatically once convergence is achieved, but at a much slower speed.

The Path Change Detector is activated by setting the PathDet bit in Control Register A3/B3 to "1". An optional path clearing feature can be enabled by setting the PathClr bit in Control Register A3/B3 to "1". With path clearing turned on, the existing echo channel estimate will also be cleared (i.e. the adaptive filter will be filled with zeroes) upon detection of a major path change.

## Non-Linear Processor (NLP)

After echo cancellation, there is always a small amount of residual echo which may still be audible. The MT9300B uses an NLP to remove residual echo signals which have a level lower than the Adaptive Suppression Threshold (TSUP in G.168). This threshold depends upon the level of the Rin (Lrin) reference signal as well as the programmed value of the Non-Linear Processor Threshold register (NLPTHR). TSUP can be calculated by the following equation:

$$TSUP = Lrin + 20\log_{10}(NLPTHR)$$

where NLPTHR is the Non-Linear Processor Threshold register value and Lrin is the relative power level expressed in dBm0.

When the level of residual error signal falls below TSUP, the NLP is activated further attenuating the residual signal by an additional 36 dB. To prevent a perceived decrease in background noise due to the activation of the NLP, a spectrally-shaped comfort noise, equivalent in power level to the background noise, is injected. This keeps the perceived noise level constant. Consequently, the user does not hear the activation and de-activation of the NLP.

The NLP processor can be disabled by setting the NLPDis bit to "1" in Control Register 2.

The NLPTHR register is 16 bits wide. The register value in hexadecimal can be calculated with the following equation:

$$NLPTHR_{(hex)} = hex(NLPTHR_{(dec)} * 32768)$$

where  $0 < NLPTHR_{(dec)} < 1$

The comfort noise injector can be disabled by setting the INJDis bit to "1" in Control Register A1/B1. It should be noted that the NLPTHR is valid and the comfort noise injection is active only when the NLP is enabled.

If the comfort noise injector is unable to correctly match the level of the background noise (because of peculiar spectral characteristics, for example), the injected level can be fine-tuned using the Noise Scaling register. A neutral value of 80<sub>(hex)</sub> will prevent any scaling. Values less than 80<sub>(hex)</sub> will reduce the noise level, values greater than 80<sub>(hex)</sub> will increase the noise level. The scaling is done linearly.

Example: To decrease the comfort noise level by 3 dB, the register value would be

$$10^{(-3 / 20)} * 128$$

$$= 0.71 * 128$$

$$= 91_{(dec)}$$

$$= 5B_{(hex)}$$

The default factory setting for the Noise Scaling register should be adequate for most operating environments. It is unlikely that it will need to be changed. It has also been set to a value which will ensure G.168 compliance.

## Disable Tone Detector

G.165 recommendation defines the disable tone as having the following characteristics: 2100 Hz ( $\pm 21$ Hz) sine wave, a power level between -6 to -31dBm0, and a phase reversal of 180 degrees ( $\pm 25$  degrees) every 450ms ( $\pm 25$ ms). If the disable tone is present for a minimum of one second with at least one phase reversal, the Tone Detector will trigger.

G.164 recommendation defines the disable tone as a 2100 Hz ( $\pm 21$ Hz) sine wave with a power level between 0 to -31dBm0. If the disable tone is present for a minimum of 400 milliseconds, with or without phase reversal, the Tone Detector will trigger.

The MT9300B has two Tone Detectors per channels (for a total of 64) in order to monitor the occurrence of a valid disable tone on both Rin and Sin. Upon detection of a disable tone, TD bit of the Status Register will indicate logic high and an interrupt is generated (i.e. IRQ pin low). Refer to Figure 5 and to the **Interrupts** section.



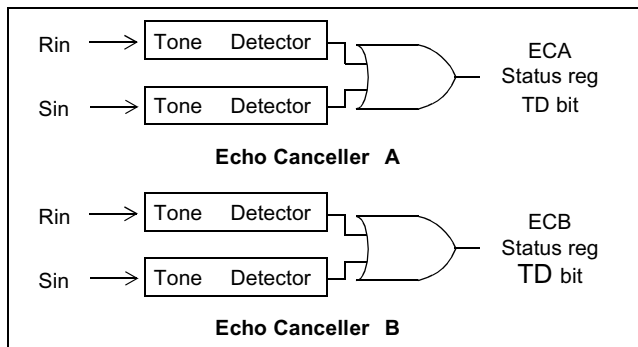

Figure 5 - Disable Tone Detection

Once a Tone Detector has been triggered, there is no longer a need for a valid disable tone (G.164 or G.165) to maintain Tone Detector status (i.e. TD bit high). The Tone Detector status will only release (i.e. TD bit low) if the signals Rin and Sin fall below -30dBm0, in the frequency range of 390Hz to 700Hz, and below -34dBm0, in the frequency range of 700Hz to 3400Hz, for at least 400ms. Whenever a Tone Detector releases, an interrupt is generated (i.e. IRQ pin low).

The selection between G.165 and G.164 tone disable is controlled by the PHDis bit in Control Register 2 on a per channel basis. When the PHDis bit is set to 1, G.164 tone disable requirements are selected.

In response to a valid disable tone, the echo canceller must be switched from the Enable Adaptation state to the Bypass state. This can be done in two ways, automatically or externally. In automatic mode, the Tone Detectors internally control the switching between Enable Adaptation and Bypass states. The automatic mode is activated by setting the AutoTD bit in Control Register 2 to high. In external mode, an external controller is needed to service the interrupts and poll the TD bits in the Status Registers. Following the detection of a disable tone (TD bit high) on a given channel, the external controller must switch the echo canceller from Enable Adaptation to Bypass state.

**Instability Detector**

In systems where the echo path return loss (ERL) is very low (<3dB), a high loop gain may result. As a consequence, an unstable condition may occur due to diverged echo canceller coefficients. This instability can result in variable pitched ringing or oscillation. Should this ringing occur, the Instability Detector will activate and suppress the oscillations.

The Instability Detector is activated by setting the RingClr bit in Control Register A3/B3 to "1".

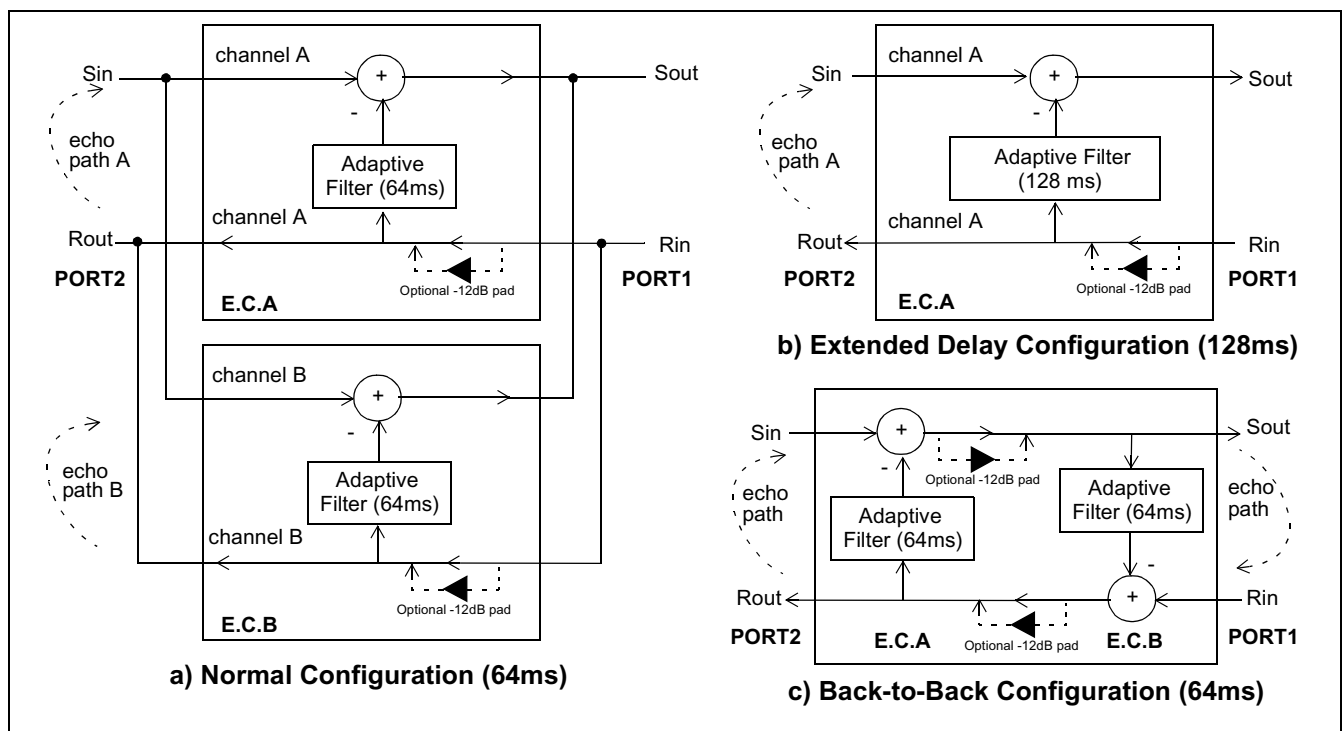

Figure 6 - Device Configuration

## Narrow Band Signal Detector (NBSD)

Single or dual frequency tones (i.e. DTMF tones) present in the receive input (Rin) of the echo canceller for a prolonged period of time may cause the Adaptive Filter to diverge. The Narrow Band Signal Detector (NBSD) is designed to prevent this by detecting single or dual tones of arbitrary frequency, phase, and amplitude. When narrow band signals are detected, adaptation is halted but the echo canceller continues to cancel echo.

The NBSD can be disabled by setting the NBDIs bit to “1” in Control Register 2.

## Offset Null Filter

Adaptive filters in general do not operate properly when a DC offset is present at any inputs. To remove the DC component, the MT9300B incorporates Offset Null filters in both Rin and Sin inputs.

The offset null filters can be disabled by setting the HPFDis bit to “1” in Control Register 2.

## ITU-T G.168 Compliance

The MT9300B has been certified G.168 compliant in all 64 ms cancellation modes (i.e. Normal and Back-to-Back configurations) by in-house testing with the DSPG ECT-1 echo canceller tester.

It should be noted that G.168 compliance is not claimed for the 128 ms Extended Delay mode, although subjectively no difference can be noticed.

## Device Configuration

The MT9300B architecture contains 32 echo cancellers divided into 16 groups. Each group has two echo cancellers which can be individually controlled (Echo Canceller A and B). They can be set in three distinct configurations: **Normal**, **Back-to-Back**, and **Extended Delay**. See Figure 6.

### Normal Configuration

In Normal configuration, the two echo cancellers (Echo Canceller A and B) are positioned in parallel, as shown in Figure 6a, providing 64 milliseconds of echo cancellation in two channels simultaneously.

### Back-to-Back Configuration

In Back-to-Back configuration, the two echo cancellers from the same group are positioned to cancel echo coming from both directions in a single

channel providing full-duplex 64ms echo cancellation. See Figure 6c. This configuration uses only one timeslot on PORT1 and PORT2 and the second timeslot normally associated with ECB contains undefined data. Back-to-Back configuration allows a no-glue interface for applications where bidirectional echo cancellation is required.

Back-to-Back configuration is selected by writing “1” into the BBM bit of **both** Control Register A1 and Control Register B1 of a given group of echo cancellers. Table 2 shows the 16 groups of 2 cancellers that can be configured into Back-to-Back.

Examples of Back-to-Back configuration include positioning one group of echo cancellers between a CODEC and a transmission device or between two codecs for echo control on analog trunks.

### Extended Delay configuration

In this configuration, the two echo cancellers from the same group are internally cascaded into one 128 milliseconds echo canceller. See Figure 6b. This configuration uses only one timeslot on PORT1 and PORT2 and the second timeslot normally associated with ECB contains undefined data.

Extended Delay configuration is selected by writing “1” into the ExtDI bit in Echo Canceller A, Control Register A1. For a given group, only Echo Canceller A, Control Register A1, has the ExtDI bit. Control Register B1, bit-0 must always be set to zero.

Table 2 shows the 16 groups of 2 cancellers that can each be configured into 64ms or 128ms echo tail capacity.

## Echo Canceller Functional States

Each echo canceller has four functional states: **Mute**, **Bypass**, **Disable Adaptation** and **Enable Adaptation**.

### Mute

In Normal and in Extended Delay configurations, writing a “1” into the MuteR bit replaces Rin with quiet code which is applied to both the Adaptive Filter and Rout. Writing a “1” into the MuteS bit replaces the Sout PCM data with quiet code.

	LINEAR 16 bits 2's complement	SIGN/ MAGNITUDE μ-Law A-Law	CCITT (G.711)	
			μ-Law	A-Law
+Zero (quiet code)	0000h	80h	FFh	D5h

**Table 1 - Quiet PCM Code Assignment**

In Back-to-Back configuration, writing a “1” into the MuteR bit of Echo Canceller A, Control Register 2, causes quiet code to be transmitted on Rout. Writing a “1” into the MuteS bit of Echo Canceller A, Control Register 2, causes quiet code to be transmitted on Sout.

In Extended Delay and in Back -to -Back configurations, MuteR and MuteS bits of Echo Canceller B must always be “0”. Refer to Figure 4 and to Control Register 2 for bit description.

Bypass

The Bypass state directly transfers PCM codes from Rin to Rout and from Sin to Sout. **When Bypass state is selected, the Adaptive Filter coefficients are reset to zero.** Bypass state must be selected for at least one frame (125 μs) in order to properly clear the filter.

Disable Adaptation

When the Disable Adaptation state is selected, the Adaptive Filter coefficients are frozen at their current value. The adaptation process is halted, however, the echo canceller continues to cancel echo.

Enable Adaptation

In Enable Adaptation state, the Adaptive Filter coefficients are continually updated. This allows the echo canceller to model the echo return path characteristics in order to cancel echo. This is the normal operating state.

The echo canceller functions are selected in Control Register A1/B1 and Control Register 2 through four control bits: MuteS, MuteR, Bypass and AdaptDis. Refer to the Registers Description for details.

**MT9300B Throughput Delay**

The throughput delay of the MT9300B varies according to the device configuration. For all device configurations, Rin to Rout has a delay of two frames and Sin to Sout has a delay of three frames. In Bypass state, the Rin to Rout and Sin to Sout paths have a delay of two frames.

**Serial PCM I/O channels**

There are two sets of TDM I/O streams, each with channels numbered from 0 to 31. One set of input streams is for Receive (Rin) channels, and the other set of input streams is for Send (Sin) channels. Likewise, one set of output streams is for Rout pcm channels, and the other set is for Sout channels. See Figure 7 for channel allocation.

The arrangement and connection of PCM channels to each echo canceller is a 2 port I/O configuration for each set of PCM Send and Receive channels, as illustrated in Figure 4.

**Serial Data Interface Timing**

The MT9300B provides ST-BUS and GCI interface timing. The Serial Interface clock frequency, C4i, is 4.096 MHz. The input and output data rate of the ST-Bus and GCI bus is 2.048 Mb/s.

The 8 KHz input frame pulse can be in either ST-BUS or GCI format. The MT9300B automatically detects the presence of an input frame pulse and identifies it as either ST-BUS or GCI. In ST-BUS format, every second falling edge of the C4i clock marks a bit boundary, and the data is clocked in on the rising edge of C4i, three quarters of the way into

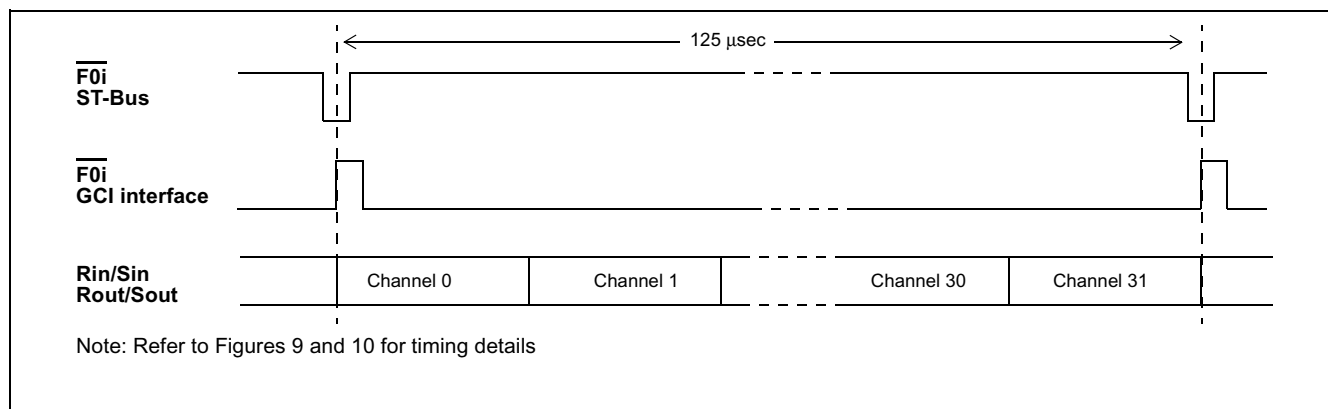

**Figure 7 - ST-BUS and GCI Interface Channel Assignment for 2Mb/s Data Streams**

the bit cell (See Figure 10). In GCI format, every second rising edge of the  $\overline{C4i}$  clock marks the bit boundary, and  $\overline{data}$  is clocked in on the second falling edge of  $\overline{C4i}$ , half the way into the bit cell (see Figure 11).

Base Addr +	Echo Canceller A	Base Addr +	Echo Canceller B
00h	Control Reg A1	20h	Control Reg B1
01h	Control Reg A2	21h	Control Reg B2
02h	Status Reg	22h	Status Reg
03h	Reserved	23h	Reserved
04h	Flat Delay Reg	24h	Flat Delay Reg
05h	Reserved	25h	Reserved
06h	Decay Step Size Reg	26h	Decay Step Size Reg
07h	Decay Step Number	27h	Decay Step Number
08h	Control Reg A3	28h	Control Reg B3
09h	Reserved	29h	Reserved
0Ah	Reserved	2Ah	Reserved
0Bh	Reserved	2Bh	Reserved
0Ch	Rin Peak Detect Reg	2Ch	Rin Peak Detect Reg
0Eh	Sin Peak Detect Reg	2Eh	Sin Peak Detect Reg
10h	Error Peak Detect Reg	30h	Error Peak Detect Reg
12h	Reserved	32h	Reserved
14h	DTDT Reg	34h	DTDT Reg
16h	Reserved	36h	Reserved
18h	NLPTHR	38h	NLPTHR
1Ah	Step Size, MU	3Ah	Step Size, MU
1Ch	Reserved	3Ch	Reserved
1Eh	Reserved	3Eh	Reserved

**Figure 8 - Memory Mapping of per channel Control and Status Registers**

**Memory Mapped Control and Status registers**

Internal memory and registers are memory mapped into the address space of the HOST interface. The internal dual ported memory is mapped into segments on a “per channel” basis to monitor and control each individual echo canceller and associated PCM channels. For example, in **Normal configuration**, echo canceller #5 makes use of Echo Canceller B from group 2. It occupies the internal address space from 0A0h to 0BFh and

interfaces to PCM channel #5 on all serial PCM I/O streams.

As illustrated in Figure 8, the “per channel” registers provide independent control and status bits for each echo canceller. Figure 9 shows the memory map of the control/status register blocks for all echo cancellers.

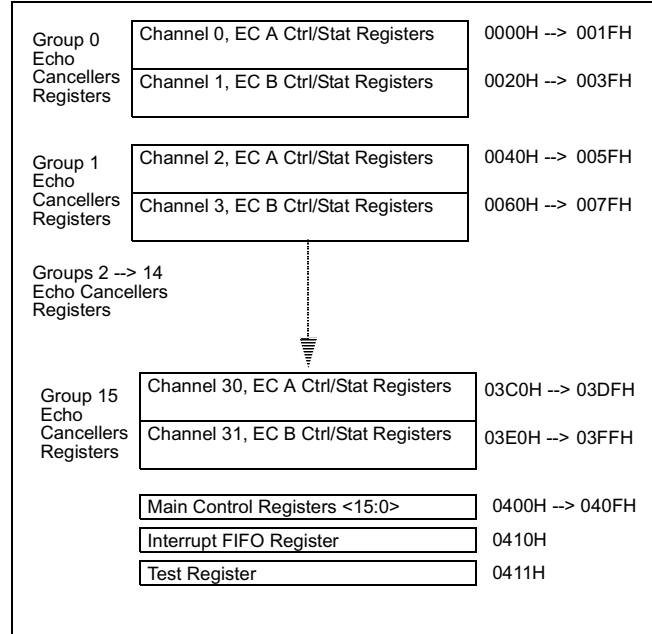

**Figure 9 - Memory Mapping**

When **Extended Delay** or **Back-to-Back** configuration is selected, Control Register A1/B1 and Control Register 2 of the selected group of echo cancellers require special care. Refer to the Register description section.

Table 2 is a list of the channels used for the 16 groups of echo cancellers when they are configured as **Extended Delay** or **Back-to-Back**

Normal Configuration

For a given group (group 0 to 15), 2 PCM I/O channels are used. For example, group 1 Echo Cancellers A and B, channels 2 and 3 are active.

Group	Channel	Group	Channel
0	0, 1	8	16, 17
1	2, 3	9	18, 19
2	4, 5	10	20, 21
3	6, 7	11	22, 23
4	8, 9	12	24, 25
5	10, 11	13	26, 27
6	12, 13	14	28, 29
7	14, 15	15	30, 31

**Table 2 - Group and Channel allocation**

#### Extended Delay Configuration

For a given group (group 0 to 15), only one PCM I/O channel is active (Echo Canceller A) and the other channel carries don't care data. For example, group 2, Echo Canceller A (Channel 4) will be active and Echo Canceller B (Channel 5) will carry don't care data.

#### Back-to-Back Configuration

For a given group (group 0 to 15), only one PCM I/O channel is active (Echo Canceller A) and the other channel carries don't care data. For example, group 5, Echo Canceller A (Channel 10) will be active and Echo Canceller B (Channel 11) will carry don't care data.

### Power Up Sequence

On power up, the  $\overline{\text{RESET}}$  pin must be held low for 100 $\mu\text{s}$ . Forcing the  $\overline{\text{RESET}}$  pin low will put the MT9300B in power down state. In this state, all internal clocks are halted, D<7:0>, Sout, Rout, DTA and  $\overline{\text{IRQ}}$  pins are tristated. The 16 Main Control Registers, the Interrupt FIFO Register and the Test Register are reset to zero.

When the  $\overline{\text{RESET}}$  pin returns to logic high and a valid MCLK is applied, the user must wait 500 $\mu\text{s}$  for PLL to lock. C4i and F0i can be active during this period. Once the PLL has locked, the user must power up the 16 groups of echo cancellers individually, by writing a "1" into the PWUP bit in each group of echo canceller's Main Control Register.

For each group of echo cancellers, when the PWUP bit toggles from zero to one, echo cancellers A and B execute their initialization routine. The initialization

routine sets their registers, Base Address+00 $_H$  to Base Address+3F $_H$ , to the default Reset Value and clears the Adaptive Filter coefficients. Two frames are necessary for the initialization routine to execute properly.

Once the initialization routine is executed, the user can set the per channel Control Registers, Base Address+00 $_H$  to Base Address+3F $_H$ , for the specific application.

### Power management

Each group of echo cancellers can be placed in Power Down mode by writing a "0" into the PWUP bit in their respective Main Control Register. When a given group is in Power Down mode, the corresponding PCM data are bypassed from Rin to Rout and from Sin to Sout with two frames delay. Refer to the Main Control Register section for description.

The typical power consumption can be calculated with the following equation:

$$P_C = 60 * \text{Nb\_of\_groups} + 40, \text{ in mW}$$

where  $0 \leq \text{Nb\_of\_groups} \leq 16$

### Call Initialization

To ensure fast initial convergence on a new call, it is important to clear the Adaptive filter. This is done by putting the echo canceller in bypass mode for at least one frame (125  $\mu\text{s}$ ) and then enabling adaptation.

### Interrupts

The MT9300B provides an interrupt pin ( $\overline{\text{IRQ}}$ ) to indicate to the HOST processor when a G.164 or G.165 Tone Disable is detected and released.

Although the MT9300B may be configured to react automatically to tone disable status on any input PCM voice channels, the user may want for the external HOST processor to respond to Tone Disable information in an appropriate, application specific manner.

Each echo canceller will generate an interrupt when a Tone Disable occurs and will generate another interrupt when a Tone Disable releases.

Upon receiving an  $\overline{\text{IRQ}}$ , the HOST CPU should read the Interrupt FIFO Register. This register is a FIFO memory containing the channel number of the echo canceller that has generated the interrupt.

All pending interrupts from any of the echo cancellers and their associated input channel number are stored in this FIFO memory. The  $\overline{\text{IRQ}}$  always returns high after a read access to the Interrupt FIFO Register. The  $\overline{\text{IRQ}}$  pin will toggle low for each pending interrupt.

After the HOST CPU has received the channel number of the interrupt source, the corresponding per channel Status Register can be read from internal memory to determine the cause of the interrupt (see Figure 7 for address mapping of Status register). The TD bit indicates the presence of a Tone Disable.

The MIRQ bit 5 in the Main Control Register 0 masks interrupts from the MT9300B. To provide more flexibility, the MTDBI (bit-4) and MTDAl (bit-3) bits in the Main Control Register<15:0> allow Tone Disable to be masked or unmasked, from generating an interrupt on a per channel basis. Refer to the Registers Description section.

## JTAG Support

The MT9300B JTAG interface conforms to the Boundary-Scan standard IEEE1149.1. This standard specifies a design-for-testability technique called Boundary-Scan test (BST). The operation of the Boundary Scan circuitry is controlled by an external Test Access Port (TAP) controller. JTAG inputs are **3.3 Volts** compliant only.

### Test Access Port (TAP)

The TAP provides access to many test functions of the MT9300B. It consists of three input pins and one output pin. The following pins are found on the TAP.

- **Test Clock Input (TCK)**  
The TCK provides the clock for the test logic. The TCK does not interfere with any on-chip clock and thus remains independent. The TCK permits shifting of test data into or out of the Boundary-Scan register cells concurrent with the operation of the device and without interfering with the on-chip logic.
- **Test Mode Select Input (TMS)**  
The logic signals received at the TMS input are interpreted by the TAP Controller to control the

test operations. The TMS signals are sampled at the rising edge of the TCK pulse. This pin is internally pulled to  $V_{DD}$  when it is not driven from an external source.

- **Test Data Input (TDI)**  
Serial input data applied to this port is fed either into the instruction register or into a test data register, depending on the sequence previously applied to the TMS input. Both registers are described in a subsequent section. The received input data is sampled at the rising edge of TCK pulses. This pin is internally pulled to  $V_{DD}$  when it is not driven from an external source.
- **Test Data Output (TDO)**  
Depending on the sequence previously applied to the TMS input, the contents of either the instruction register or data register are serially shifted out towards the TDO. The data from the TDO is clocked on the falling edge of the TCK pulses. When no data is shifted through the Boundary Scan cells, the TDO driver is set to a high impedance state.
- **Test Reset ( $\overline{\text{TRST}}$ )**  
This pin is used to reset the JTAG scan structure. This pin is internally pulled to  $V_{SS}$ .

## Instruction Register

In accordance with the IEEE 1149.1 standard, the MT9300B uses public instructions. The JTAG Interface contains a 3-bit instruction register. Instructions are serially loaded into the instruction register from the TDI when the TAP Controller is in its shifted-IR state. Subsequently, the instructions are decoded to achieve two basic functions: to select the test data register that will operate while the instruction is current, and to define the serial test data register path, which is used to shift data between TDI and TDO during data register scanning.

### Test Data Registers

As specified in IEEE 1149.1, the MT9300B JTAG Interface contains three test data registers:

- **Boundary-Scan register**  
The Boundary-Scan register consists of a series of Boundary-Scan cells arranged to form a scan path around the boundary of the MT9300B core logic.

- **Bypass Register**  
The Bypass register is a single stage shift register that provides a one-bit path from TDI to TDO.
- **Device Identification register**  
The Device Identification register provides access to the following encoded information: device version number, part number and manufacturer's name.

Register Descriptions

<p><b>Echo Canceller A, Control Register A1</b></p>			Read/Write Address: 00 <sub>H</sub> + Base Address					
7	6	5	4	3	2	1	0	
Reset	INJDis	BBM	PAD	Bypass	AdpDis	0	ExtDI	Reset Value: 00 <sub>H</sub>
<p><b>Echo Canceller B, Control Register B1</b></p>			Read/Write Address: 20 <sub>H</sub> + Base Address					
7	6	5	4	3	2	1	0	
Reset	INJDis	BBM	PAD	Bypass	AdpDis	1	0	Reset Value: 02 <sub>H</sub>
Bit	Name	Description						
7	Reset	When high, the power-up initialization is executed which presets all register bits including this bit and clears the Adaptive Filter coefficients.						
6	INJDis	When high, the noise injection process is disabled. When low noise injection is enabled.						
5	BBM	When high the Back to Back configuration is enabled. When low the Normal configuration is enabled. Note: Do not enable Extended-Delay and BBM configurations at the same time. Always set <b>both</b> BBM bits of the two echo cancellers (Control Register A1 and Control Register B1) of the same group to the same logic value to avoid conflict.						
4	PAD	When high, 12dB of attenuation is inserted into the Rin to Rout path. When low the Rin to Rout path gain is 0dB.						
3	Bypass	When high, Sin data is by-passed to Sout and Rin data is by-passed to Rout. The Adaptive Filter coefficients are set to zero and the filter adaptation is stopped. When low, output data on both Sout and Rout is a function of the echo canceller algorithm.						
2	AdpDis	When high, echo canceller adaptation is disabled. The MT9300B cancels echo. When low, the echo canceller dynamically adapts to the echo path characteristics.						
1	0 or 1	Bits marked as "1" or "0" are reserved bits and should be written as indicated.						
0	ExtDI or 0	When high, Echo Cancellers A and B of the same group are internally cascaded into one 128ms echo canceller. When low, Echo Cancellers A and B of the same group operate independently. Note: Do not enable both Extended-Delay and BBM configurations at the same time. Control Register B1 bit-0 is a reserved bit and should be written "0".						



<b>Echo Cancellor A, Control Register A2</b>		Read/Write Address: 01 <sub>H</sub> + Base Address														
<b>Echo Cancellor B, Control Register B2</b>		Read/Write Address: 21 <sub>H</sub> + Base Address														
7	6	5	4	3	2	1	0									
<table border="1"> <tr> <td>TDis</td> <td>PHDis</td> <td>NLPDis</td> <td>AutoTD</td> <td>NBDis</td> <td>HPFDis</td> <td>MuteS</td> <td>MuteR</td> </tr> </table>								TDis	PHDis	NLPDis	AutoTD	NBDis	HPFDis	MuteS	MuteR	Reset Value: 00 <sub>H</sub>
TDis	PHDis	NLPDis	AutoTD	NBDis	HPFDis	MuteS	MuteR									
Bit	Name	Description														
7	TDis	When high, tone detection is disabled. When low, tone detection is enabled. When both Echo Cancellers A and B TDis bits are high, Tone Disable processors are disabled entirely and are put into power down mode.														
6	PHDis	When high, the tone detectors will trigger upon the presence of a 2100Hz tone regardless of the presence/absence of periodic phase reversals. When low, the tone detectors will trigger only upon the presence of a 2100Hz tone with periodic phase reversals.														
5	NLPDis	When high, the non-linear processor is disabled. When low, the non-linear processors function normally. Useful for G.165 conformance testing.														
4	AutoTD	When high, the echo canceller puts itself in Bypass mode when the tone detectors detect the presence of 2100Hz tone. See PHDis for qualification of 2100Hz tones. When low, the echo canceller algorithm will remain operational regardless of the state of the 2100Hz tone detectors.														
3	NBDis	When high, the narrow-band detector is disabled. When low, the narrow-band detector is enabled.														
2	HPFDis	When high, the offset nulling high pass filters are bypassed in the Rin and Sin paths. When low, the offset nulling filters are active and will remove DC offsets on PCM input signals.														
1	MuteS	When high, data on Sout is muted to quiet code. When low, Sout carries active code.														
0	MuteR	When high, data on Rout is muted to quiet code. When low, Rout carries active code.														

<b>Echo Celler A, Status Register</b>		Read Address:	02 <sub>H</sub> + Base Address					
<b>Echo Celler B, Status Register</b>		Read Address:	22 <sub>H</sub> + Base Address					
7	6	5	4	3	2	1	0	
res	TD	DTDet	res	res	res	TDG	NB	Reset Value: 00 <sub>H</sub>
Bit	Name	Description						
7	res	Reserved bit.						
6	TD	Logic high indicates the presence of a 2100Hz tone.						
5	DTDet	Logic high indicates the presence of a double-talk condition.						
4	res	Reserved bit.						
3	res	Reserved bit.						
2	res	Reserved bit.						
1	TDG	Tone detection status bit gated with the AutoTD bit. Logic high indicates that AutoTD has been enabled and the tone detector has detected the presence of a 2100Hz tone.						
0	NB	Logic high indicates the presence of a narrow-band signal on Rin.						

**Echo Canceller A, Flat Delay Register (FD)**  
**Echo Canceller B, Flat Delay Register (FD)**

Read/Write Address:  $04_H + \text{Base Address}$   
 Read/Write Address:  $24_H + \text{Base Address}$

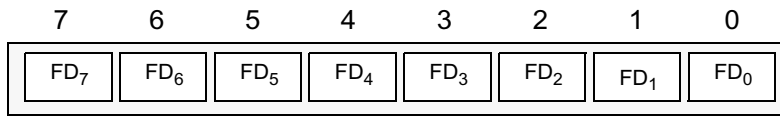

Power Reset Value  
 $00_H$

**Echo Canceller A, Decay Step Number Register (NS)**  
**Echo Canceller B, Decay Step Number Register (NS)**

Read/Write Address:  $07_H + \text{Base Address}$   
 Read/Write Address:  $27_H + \text{Base Address}$

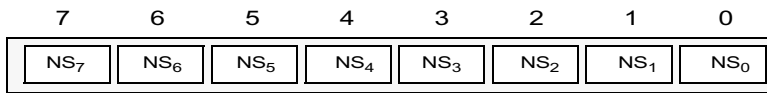

Power Reset Value  
 $00_H$

**Echo Canceller A, Decay Step Size Control Register (SSC)**  
**Echo Canceller B, Decay Step Size Control Register (SSC)**

Read/Write Address:  $06_H + \text{Base Address}$   
 Read/Write Address:  $26_H + \text{Base Address}$

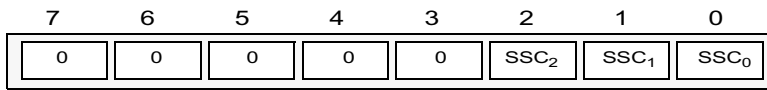

Power Reset Value  
 $04_H$

*Note: Bits marked with "0" are reserved bits and should be written "0".*

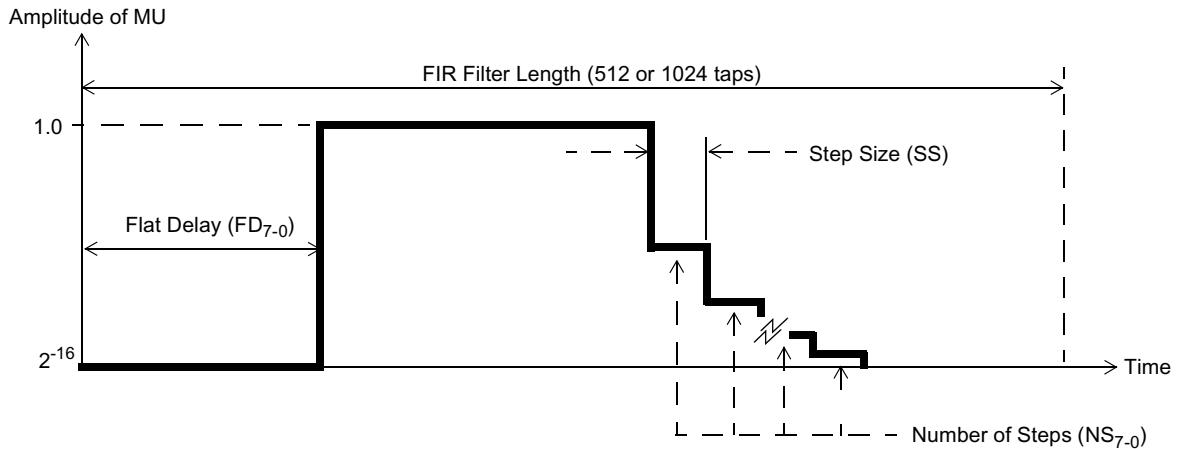

The Exponential Decay registers (Decay Step Number and Decay Step Size) and Flat Delay register allow the LMS adaptation step-size (MU) to be programmed over the length of the FIR filter. A programmable MU profile allows the performance of the echo canceller to be optimized for specific applications. For example, if the characteristic of the echo response is known to have a flat delay of several milliseconds and a roughly exponential decay of the echo impulse response, then the MU profile can be programmed to approximate this expected impulse response thereby improving the convergence characteristics of the Adaptive Filter. Note that in the following register descriptions, one tap is equivalent to 125µs (64ms/512 taps).

**FD<sub>7-0</sub> Flat Delay:** This register defines the flat delay of the MU profile, (i.e., where the MU value is  $2^{-16}$ ). The delay is defined as  $FD_{7-0} \times 8$  taps. For example; if  $FD_{7-0} = 5$ , then  $MU=2^{-16}$  for the first 40 taps of the echo canceller FIR filter. The valid range of  $FD_{7-0}$  is:  $0 \leq FD_{7-0} \leq 64$  in normal mode and  $0 \leq FD_{7-0} \leq 128$  in extended-delay mode. **The default value of  $FD_{7-0}$  is zero.**

**SSC<sub>2-0</sub> Decay Step Size Control:** This register controls the step size (SS) to be used during the exponential decay of MU. The decay rate is defined as a decrease of MU by a factor of 2 every SS taps of the FIR filter, where  $SS = 4 \times 2^{SSC_{2-0}}$ . For example; if  $SSC_{2-0} = 4$ , then MU is reduced by a factor of 2 every 64 taps of the FIR filter. **The default value of  $SSC_{2-0}$  is 04h.**

**NS<sub>7-0</sub> Decay Step Number:** This register defines the number of steps to be used for the decay of MU where each step has a period of SS taps (see  $SSC_{2-0}$ ). The start of the exponential decay is defined as:  
**Filter Length (512 or 1024) - [Decay Step Number (NS<sub>7-0</sub>) x Step Size (SS)]** where  $SS = 4 \times 2^{SSC_{2-0}}$ .  
 For example, if  $NS_{7-0}=4$  and  $SSC_{2-0}=4$ , then the exponential decay start value is  $512 - [NS_{7-0} \times SS] = 512 - [4 \times (4 \times 2^4)] = 256$  taps for a filter length of 512 taps.

<b>Echo Cancellor A, Control Register A3</b> <b>Echo Cancellor B, Control Register B3</b>		Read/Write Address: $08_H + \text{Base Address}$ Read/Write Address: $28_H + \text{Base Address}$								
7    6    5    4    3    2    1    0		Reset Value: $0A_H$								
<table border="1" style="margin: auto; border-collapse: collapse;"> <tr> <td style="padding: 2px 5px;">res</td> <td style="padding: 2px 5px;">res</td> <td style="padding: 2px 5px;">res</td> <td style="padding: 2px 5px;">res</td> <td style="padding: 2px 5px;">RingClr</td> <td style="padding: 2px 5px;">PathClr</td> <td style="padding: 2px 5px;">PathDet</td> <td style="padding: 2px 5px;">res</td> </tr> </table>		res	res	res	res	RingClr	PathClr	PathDet	res	
res	res	res	res	RingClr	PathClr	PathDet	res			
Bit	Name	Description								
7-4	res	Reserved bits. Must always be set to zero for normal operation.								
3	RingClr	When high, the instability detector is activated. When low, the instability detector is disabled.								
2	PathClr	When high, the current echo channel estimate will be cleared and the echo canceller will enter fast convergence mode upon detection of a path change. When low, the echo canceller will keep the current path estimate but revert to fast convergence mode upon detection of a path change. Note: this bit is ignored if PathDet is low.								
1	PathDet	When high, the path change detector is activated. When low, the path change detector is disabled.								
0	res	Reserved bit. Must always be set to zero for normal operation.								

**Echo Cancellor A, Rin Peak Detect Register 2 (RP)**  
**Echo Cancellor B, Rin Peak Detect Register 2 (RP)**

Read Address:  $0D_H + \text{Base Address}$   
 Read Address:  $2D_H + \text{Base Address}$

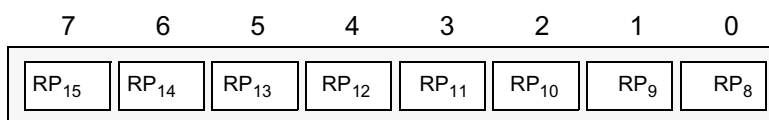

Power Reset Value  
N/A

**Echo Cancellor A, Rin Peak Detect Register 1 (RP)**  
**Echo Cancellor B, Rin Peak Detect Register 1 (RP)**

Read Address:  $0C_H + \text{Base Address}$   
 Read Address:  $2C_H + \text{Base Address}$

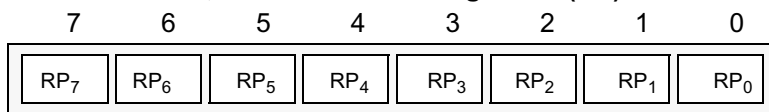

Power Reset Value  
N/A

These peak detector registers allow the user to monitor the receive in signal (Rin) peak signal level. The information is in 16-bit 2's complement linear coded format presented in two 8 bit registers for each echo canceller. The high byte is in Register 2 and the low byte is in Register 1.

**Echo Cancellor A, Sin Peak Detect Register 2 (SP)**  
**Echo Cancellor B, Sin Peak Detect Register 2 (SP)**

Read Address:  $0F_H + \text{Base Address}$   
 Read Address:  $2F_H + \text{Base Address}$

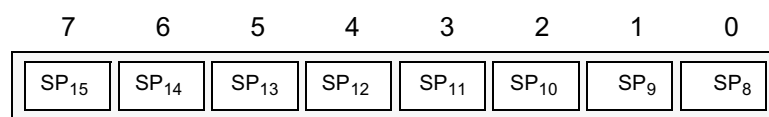

Power Reset Value  
N/A

**Echo Cancellor A, Sin Peak Detect Register 1 (SP)**  
**Echo Cancellor B, Sin Peak Detect Register 1 (SP)**

Read Address:  $0E_H + \text{Base Address}$   
 Read Address:  $2E_H + \text{Base Address}$

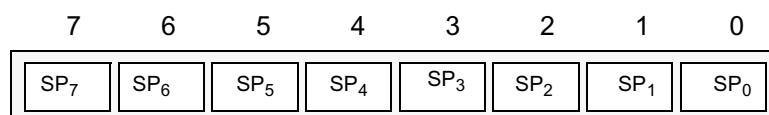

Power Reset Value  
N/A

These peak detector registers allow the user to monitor the send in signal (Sin) peak signal level. The information is in 16-bit 2's complement linear coded format presented in two 8 bit registers for each echo canceller. The high byte is in Register 2 and the low byte is in Register 1.

**Echo Cancellor A, Error Peak Detect Register 2 (EP)**  
**Echo Cancellor B, Error Peak Detect Register 2 (EP)**

Read Address:  $11_H + \text{Base Address}$   
 Read Address:  $31_H + \text{Base Address}$



Power Reset Value  
N/A

**Echo Cancellor A, Error Peak Detect Register 1 (EP)**  
**Echo Cancellor B, Error Peak Detect Register 1 (EP)**

Read Address:  $10_H + \text{Base Address}$   
 Read Address:  $30_H + \text{Base Address}$



Power Reset Value  
N/A

These peak detector registers allow the user to monitor the error signal peak level. The information is in 16-bit 2's complement linear coded format presented in two 8 bit registers for each echo canceller. The high byte is in Register 2 and the low byte is in Register 1.

**Echo Canceller A, Double-Talk Detection Threshold Register 2** Read/Write Address: 15<sub>H</sub> + Base Address  
**Echo Canceller B, Double-Talk Detection Threshold Register 2** Read/Write Address: 35<sub>H</sub> + Base Address

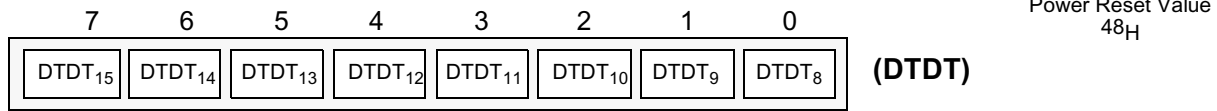

**Echo Canceller A, Double-Talk Detection Threshold Register 1** Read/Write Address: 14<sub>H</sub> + Base Address  
**Echo Canceller B, Double-Talk Detection Threshold Register 1** Read/Write Address: 34<sub>H</sub> + Base Address

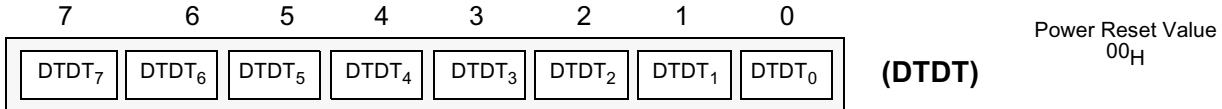

This register allows the user to program the level of Double-Talk Detection Threshold (DTDT). The 16 bit 2's complement linear value **defaults** to 4800h = 0.5625 or -5dB. The maximum value is 7FFFh = 0.9999 or 0 dB. The high byte is in Register 2 and the low byte is in Register 1.

**Echo Canceller A, Non-Linear Processor Threshold Register 2** Read/Write Address: 19<sub>H</sub> + Base Address  
**Echo Canceller B, Non-Linear Processor Threshold Register 2** Read/Write Address: 39<sub>H</sub> + Base Address

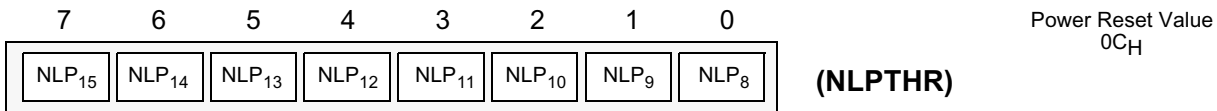

**Echo Canceller A, Non-Linear Processor Threshold Register 1** Read/Write Address: 18<sub>H</sub> + Base Address  
**Echo Canceller B, Non-Linear Processor Threshold Register 1** Read/Write Address: 38<sub>H</sub> + Base Address

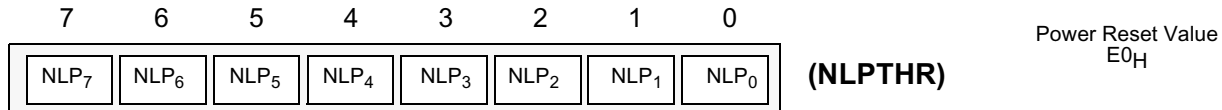

This register allows the user to program the level of the Non-Linear Processor Threshold (NLPTHR). The 16 bit 2's complement linear value **defaults** to 0B60h = 0.0889 or -21.0dB. The maximum value is 7FFFh = 0.9999 or 0 dB. The high byte is in Register 2 and the low byte is in Register 1.

**Echo Canceller A, Adaptation Step Size (MU) Register 2** Read/Write Address: 1B<sub>H</sub> + Base Address  
**Echo Canceller B, Adaptation Step Size (MU) Register 2** Read/Write Address: 3B<sub>H</sub> + Base Address

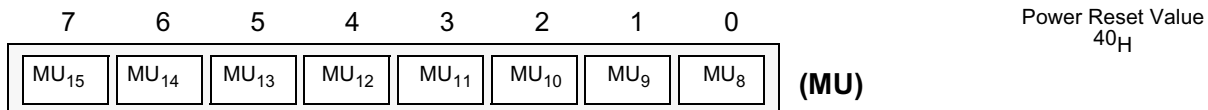

**Echo Canceller A, Adaptation Step Size (MU) Register 1** Read/Write Address: 1A<sub>H</sub> + Base Address  
**Echo Canceller B, Adaptation Step Size (MU) Register 1** Read/Write Address: 3A<sub>H</sub> + Base Address

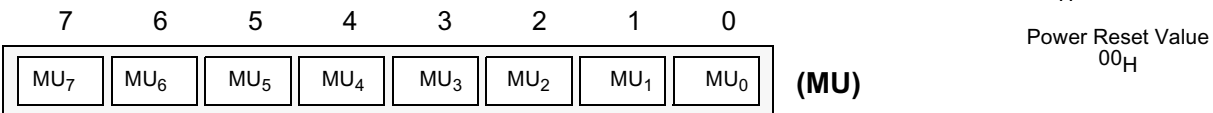

This register allows the user to program the level of MU. MU is a 16 bit 2's complement value which defaults to 4000h = 1.0. The maximum value is 7FFFh or 1.9999 decimal. The high byte is in Register 2 and the low byte is in Register 1.

Main Control Register 0 (EC group 0)		Read/Write Address: 400 <sub>H</sub>
<div style="display: flex; justify-content: space-around; align-items: center;"> <span>7</span> <span>6</span> <span>5</span> <span>4</span> <span>3</span> <span>2</span> <span>1</span> <span>0</span> </div> <div style="display: flex; justify-content: space-around; align-items: center; margin-top: 5px;"> <div style="border: 1px solid black; padding: 2px;">WR_all</div> <div style="border: 1px solid black; padding: 2px;">ODE</div> <div style="border: 1px solid black; padding: 2px;">MIRQ</div> <div style="border: 1px solid black; padding: 2px;">MTDBI</div> <div style="border: 1px solid black; padding: 2px;">MTDAI</div> <div style="border: 1px solid black; padding: 2px;">Format</div> <div style="border: 1px solid black; padding: 2px;">LAW</div> <div style="border: 1px solid black; padding: 2px;">PWUP</div> </div>		Reset Value: 00 <sub>H</sub>
Bit	Name	Description
7	WR_all	Write all control bit: When high, Group 0-15 Echo Cancellers Registers are mapped into 0000h to 0003Fh which is Group 0 address mapping. Useful to initialize the 16 Groups of Echo Cancellers as per Group 0. When low, address mapping is per Figure 8. <b>Note:</b> Only the <b>Main Control Register 0</b> has the WR_all bit.
6	ODE	Output Data Enable: This control bit is logically AND'd with the ODE input pin. When both ODE bit and ODE input pin are high, the Rout and Sout outputs are enabled. When the ODE bit is low or the ODE input pin is low, the Rout and Sout outputs are high impedance. <b>Note:</b> Only the <b>Main Control Register 0</b> has the ODE bit.
5	MIRQ	Mask Interrupt: When high, all the interrupts from the Tone Detectors output are masked. The Tone Detectors operate as specified in their Echo Cancellor B, Control Register 2. When low, the Tone Detectors Interrupts are active. <b>Note:</b> Only the <b>Main Control Register 0</b> has the MIRQ bit.
4	MTDBI	Mask Tone Detector B Interrupt: When high, the Tone Detector interrupt output from Echo Cancellor B is masked. The Tone Detector operates as specified in Echo Cancellor B, Control Register 2. When low, the Tone Detector B Interrupt is active.
3	MTDAI	Mask Tone Detector A Interrupt: When high, the Tone Detector interrupt output from Echo Cancellor A is masked. The Tone Detector operates as specified in Echo Cancellor A, Control Register 2. When low, the Tone Detector A Interrupt is active.
2	Format	ITU-T/Sign Mag: When high, both Echo Cancellers A and B for a given group, accept ITU-T (G.711) PCM code. When low, both Echo Cancellers A and B for a given group, accept sign-magnitude PCM code.
1	LAW	A/μ Law: When high, both Echo Cancellers A and B for a given group, accept A-Law companded PCM code. When low, both Echo Cancellers A and B for a given group, accept μ-Law companded PCM code.
0	PWUP	Power-UP: When high, both Echo Cancellers A and B and Tone Detectors for a given group, are active. When low, both Echo Cancellers A and B and Tone Detectors for a given group, are placed in Power Down mode. In this mode, the corresponding PCM data are bypassed from Rin to Rout and from Sin to Sout with two frames delay. When the PWUP bit toggles from zero to one, the echo canceller A and B execute their initialization routine which presets their registers, Base Address+00H to Base Address+3FH, to default Reset Value and clears the Adaptive Filter coefficients. Two frames are necessary for the initialization routine to execute properly. Once the initialization routine is executed, the user can set the per channel Control Registers for their specific application.

7	6	5	4	3	2	1	0	
unused	unused	unused	MTDBI	MTDAI	Format	LAW	PWUP	Reset Value: 00 <sub>H</sub>
Main Control Register 1	(EC group 1)		Read/Write Address:		401 <sub>H</sub>			
Main Control Register 2	(EC group 2)		Read/Write Address:		402 <sub>H</sub>			
Main Control Register 3	(EC group 3)		Read/Write Address:		403 <sub>H</sub>			
Main Control Register 4	(EC group 4)		Read/Write Address:		404 <sub>H</sub>			
Main Control Register 5	(EC group 5)		Read/Write Address:		405 <sub>H</sub>			
Main Control Register 6	(EC group 6)		Read/Write Address:		406 <sub>H</sub>			
Main Control Register 7	(EC group 7)		Read/Write Address:		407 <sub>H</sub>			
Main Control Register 8	(EC group 8)		Read/Write Address:		408 <sub>H</sub>			
Main Control Register 9	(EC group 9)		Read/Write Address:		409 <sub>H</sub>			
Main Control Register 10	(EC group 10)		Read/Write Address:		40A <sub>H</sub>			
Main Control Register 11	(EC group 11)		Read/Write Address:		40B <sub>H</sub>			
Main Control Register 12	(EC group 12)		Read/Write Address:		40C <sub>H</sub>			
Main Control Register 13	(EC group 13)		Read/Write Address:		40D <sub>H</sub>			
Main Control Register 14	(EC group 14)		Read/Write Address:		40E <sub>H</sub>			
Main Control Register 15	(EC group 15)		Read/Write Address:		40F <sub>H</sub>			

Bit	Name	Description
7-5	unused	Unused Bits.
4	MTDBI	Mask Tone Detector B Interrupt: When high, the Tone Detector interrupt output from Echo Canceller B is masked. The Tone Detector operates as specified in Echo Canceller B, Control Register 2. When low, the Tone Detector B Interrupt is active.
3	MTDAI	Mask Tone Detector A Interrupt: When high, the Tone Detector interrupt output from Echo Canceller A is masked. The Tone Detector operates as specified in Echo Canceller A, Control Register 2. When low, the Tone Detector A Interrupt is active.
2	Format	ITU-T/Sign Mag: When high, both Echo Cancellers A and B for a given group, select ITU-T (G.711) PCM code. When low, both Echo Cancellers A and B for a given group, select sign-magnitude PCM code.
1	LAW	A/μ Law: When high, both Echo Cancellers A and B for a given group, select A-Law companded PCM code. When low, both Echo Cancellers A and B for a given group, select m-Law companded PCM code.
0	PWUP	Power-UP: When high, both Echo Cancellers A and B and Tone Detectors for a given group, are active. When low, both Echo Cancellers A and B and Tone Detectors for a given group, are placed in Power Down mode. In this mode, the corresponding PCM data are bypassed from Rin to Rout and from Sin to Sout with two frames delay. When the PWUP bit toggles from zero to one, the echo cancellers A and B execute their initialization routine which presets their registers, Base Address+00H to Base Address+3FH, to default Reset Value and clears the Adaptive Filter coefficients. Two frames are necessary for the initialization routine to execute properly. Once the initialization routine is executed, the user can set the per channel Control Registers for their specific application.



<b>Interrupt FIFO Register</b>			Read Address: 410 <sub>H</sub> (Read only)					
7	6	5	4	3	2	1	0	
IRQ	0	0	I4	I3	I2	I1	I0	Reset Value: 00 <sub>H</sub>
Bit	Name	Description						
7	IRQ	Logic high indicates an interrupt has occurred. IRQ bit is cleared after the Interrupt FIFO register is read. Logic Low indicates that no interrupt is pending and the FIFO is empty.						
6:5	0	Unused bits. Always zero						
4:0	I<4:0>	I<4:0> binary code indicates the channel number at which a Tone Detector state change has occurred. Note: Whenever a Tone Disable is detected or released, an interrupt is generated.						

<b>Test Register</b>			Read/Write Address: 411 <sub>H</sub>					
7	6	5	4	3	2	1	0	
res	res	res	res	res	res	res	Tirq	Reset Value: 00 <sub>H</sub>
Bit	Name	Description						
7:1	res	Reserved bits. Must always be set to zero for normal operation.						
0	Tirq	Test IRQ: Useful for the application engineer to verify the interrupt service routine. When high, any change to MTDBI and MTDAl bits of the Main Control Register will cause an interrupt and its corresponding channel number will be available from the Interrupt FIFO Register. When low, normal operation is selected.						

**Absolute Maximum Ratings\***

	Parameter	Symbol	Min	Max	Units
1	Supply Voltage	$V_{DD1}$	-0.3	5.0	V
2	Voltage on any 3.3V I/O pins (other than supply pins)	$V_{I3}$	$V_{SS} - 0.3$	$V_{DD1} + 0.5$	V
3	Voltage on any 5V Tolerant I/O pins (other than supply pins)	$V_{I5}$	$V_{SS} - 0.3$	5.5	V
4	Continuous Current at digital outputs	$I_O$		20	mA
5	Package power dissipation	$P_D$		2.0	W
6	Storage temperature	$T_S$	-55	150	°C

\* Exceeding these values may cause permanent damage. Functional operation under these conditions is not implied.

**Recommended Operating Conditions** - Voltages are with respect to ground ( $V_{SS}$ ) unless otherwise stated.

	Characteristics	Sym	Min	Typ <sup>‡</sup>	Max	Units	Test Conditions
1	Operating Temperature	$T_{OP}$	-40		+85	°C	
2	Positive Supply	$V_{DD1}$	3.0	3.3	3.6	V	
3	Input High Voltage on 3.3V tolerant	$V_{IH3}$	$0.7V_{DD1}$		$V_{DD1}$	V	
4	Input High Voltage on 5V tolerant	$V_{IH5}$	$0.7V_{DD1}$		5.5	V	
5	Input Low Voltage	$V_{IL}$			$0.3V_{DD1}$	V	

‡ Typical figures are at 25°C and are for design aid only: not guaranteed and not subject to production testing

**DC Electrical Characteristics<sup>†</sup>** - Voltages are with respect to ground ( $V_{SS}$ ) unless otherwise stated.

	Characteristics	Sym	Min	Typ <sup>‡</sup>	Max	Units	Test Conditions	
1	Supply Current	$I_{CC}$			250	μA	RESET = 0	
		$I_{DD}$		308	375	mA	All channels active	
2	Power Consumption	$P_C$		1.0	1.35	W	All channels active	
3	I N P U T S	Input High Voltage	$V_{IH}$	$0.7V_{DD1}$		V		
4		Input Low Voltage	$V_{IL}$		$0.3V_{DD1}$	V		
5		Input Leakage	$I_{IH}/I_{IL}$			10	μA	$V_{IN}=V_{SS}$ to $V_{DD1}$ or 5.5V
		Input Leakage on Pullup	$I_{LU}$		-30	-55	μA	$V_{IN}=V_{SS}$
	Input Leakage on Pulldown	$I_{LD}$		30	65	μA	$V_{IN}=V_{DD1}$ See Note 1	
6	Input Pin Capacitance	$C_I$			10	pF		
7	O U T P U T S	Output High Voltage	$V_{OH}$	$0.8V_{DD1}$		V	$I_{OH} = 12$ mA	
8		Output Low Voltage	$V_{OL}$		0.4	V	$I_{OL} = 12$ mA	
9		High Impedance Leakage	$I_{OZ}$			10	μA	$V_{IN}=V_{SS}$ to 5.5V
10		Output Pin Capacitance	$C_O$			10	pF	

† Characteristics are over recommended operating conditions unless otherwise stated

‡ Typical figures are at 25°C,  $V_{DD1}=3.3V$  and are for design aid only: not guaranteed and not subject to production testing.

\* Note 1: Maximum leakage on pins (output or I/O pins in high impedance state) is over an applied voltage ( $V_{IN}$ ).

**AC Electrical Characteristics<sup>†</sup> - Timing Parameter Measurement Voltage Levels**

- Voltages are with respect to ground ( $V_{SS}$ ) unless otherwise stated.

	Characteristics	Sym	Level	Units	Conditions
1	CMOS Threshold	$V_{TT}$	$0.5V_{DD1}$	V	
2	CMOS Rise/Fall Threshold Voltage High	$V_{HM}$	$0.7V_{DD1}$	V	
3	CMOS Rise/Fall Threshold Voltage Low	$V_{LM}$	$0.3V_{DD1}$	V	

<sup>†</sup> Characteristics are over recommended operating conditions unless otherwise stated

**AC Electrical Characteristics<sup>†</sup> - Frame Pulse and  $\overline{C4i}$** 

	Characteristic	Sym	Min	Typ <sup>‡</sup>	Max	Units	Notes
1	Frame pulse width (ST-BUS, GCI)	$t_{FPW}$	20		$2^*$ $t_{CP}-20$	ns	
2	Frame Pulse Setup time before $\overline{C4i}$ falling (ST-BUS or GCI)	$t_{FPS}$	10	122	150	ns	
3	Frame Pulse Hold Time from $\overline{C4i}$ falling (ST-BUS or GCI)	$t_{FPH}$	10	122	150	ns	
4	$\overline{C4i}$ Period	$t_{CP}$	190	244.1	300	ns	
5	$\overline{C4i}$ Pulse Width High	$t_{CH}$	85		150	ns	
6	$\overline{C4i}$ Pulse Width Low	$t_{CL}$	85		150	ns	
7	$\overline{C4i}$ Rise/Fall Time	$t_r, t_f$			10	ns	

<sup>†</sup> Characteristics are over recommended operating conditions unless otherwise stated

<sup>‡</sup> Typical figures are at 25°C,  $V_{DD1}=3.3V$  and for design aid only: not guaranteed and not subject to production testing

**AC Electrical Characteristics<sup>†</sup> - Serial Streams for ST-BUS and GCI Backplanes**

	Characteristic	Sym	Min	Typ <sup>‡</sup>	Max	Units	Test Conditions
1	Rin/Sin Set-up Time	$t_{SIS}$	10			ns	
2	Rin/Sin Hold Time	$t_{SIH}$	10			ns	
3	Rout/Sout Delay - Active to Active	$t_{SOD}$			60	ns	$C_L=150pF$
4	Output Data Enable (ODE) Delay	$t_{ODE}$			30	ns	$C_L=150pF, R_L=1K$ See Note 1

<sup>†</sup> Characteristics are over recommended operating conditions unless otherwise stated

<sup>‡</sup> Typical figures are at 25°C,  $V_{DD1}=3.3V$  and for design aid only: not guaranteed and not subject to production testing

\* Note1: High Impedance is measured by pulling to the appropriate rail with  $R_L$ , with timing corrected to cancel time taken to discharge  $C_L$ .

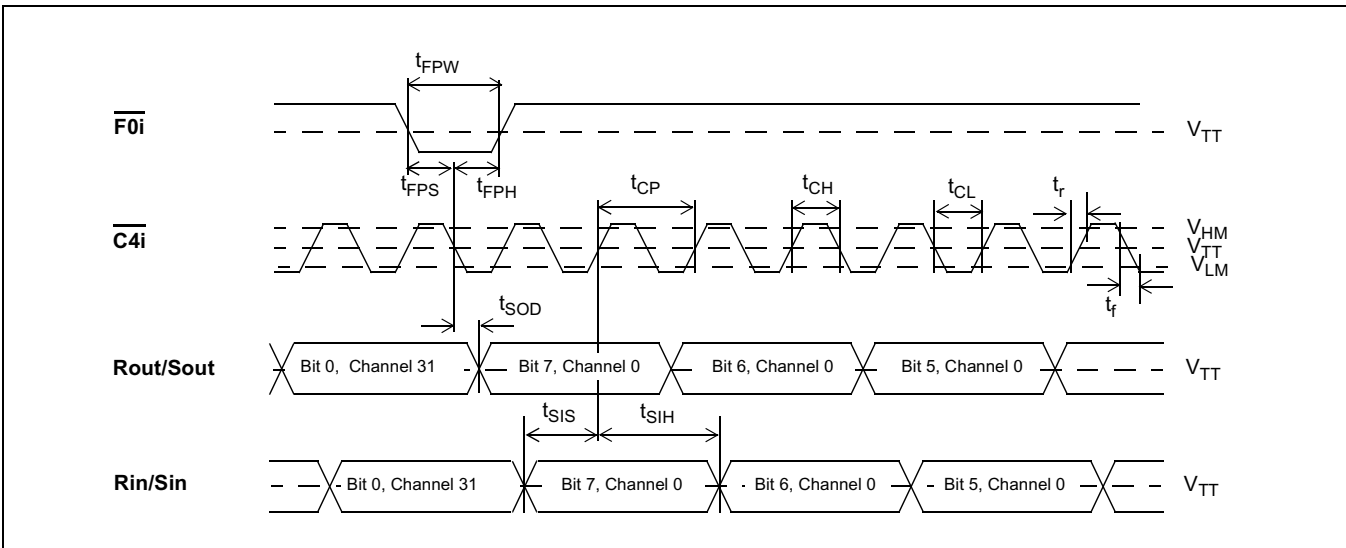

Figure 10 - ST-BUS Timing at 2.048 Mb/s

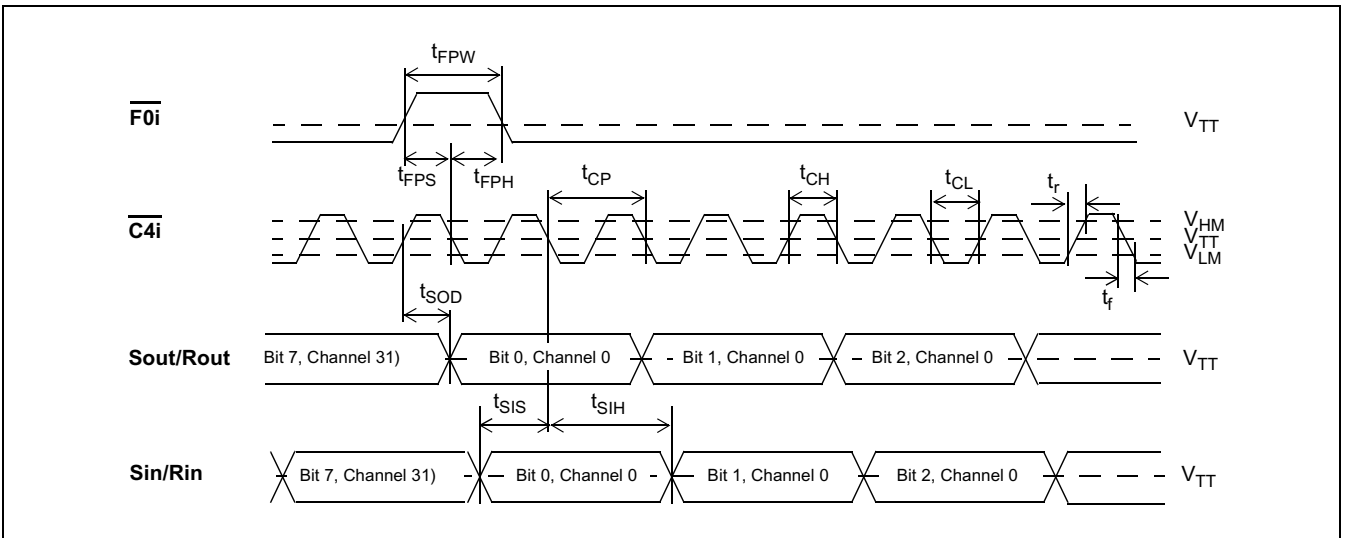

Figure 11 - GCI Interface Timing at 2.048 Mb/s

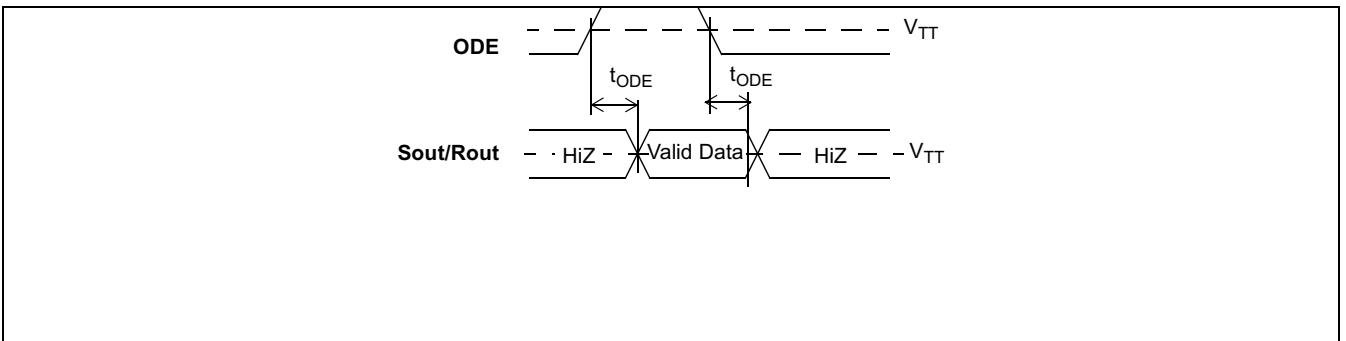

Figure 12 - Output Driver Enable (ODE)

**AC Electrical Characteristics† - Master Clock** - Voltages are with respect to ground ( $V_{SS}$ ). unless otherwise stated.

	Characteristic	Sym	Min	Typ‡	Max	Units	Notes
1	Master Clock Frequency, - Fsel = 0 - Fsel = 1	$f_{MCF0}$ $f_{MCF1}$	19.0 9.5	20.0 10.0	21.0 10.5	MHz MHz	
2	Master Clock Low	$t_{MCL}$	20			ns	
3	Master Clock High	$t_{MCH}$	20			ns	

† Characteristics are over recommended operating conditions unless otherwise stated

‡ Typical figures are at 25°C,  $V_{DD1}=3.3V$  and for design aid only: not guaranteed and not subject to production testing

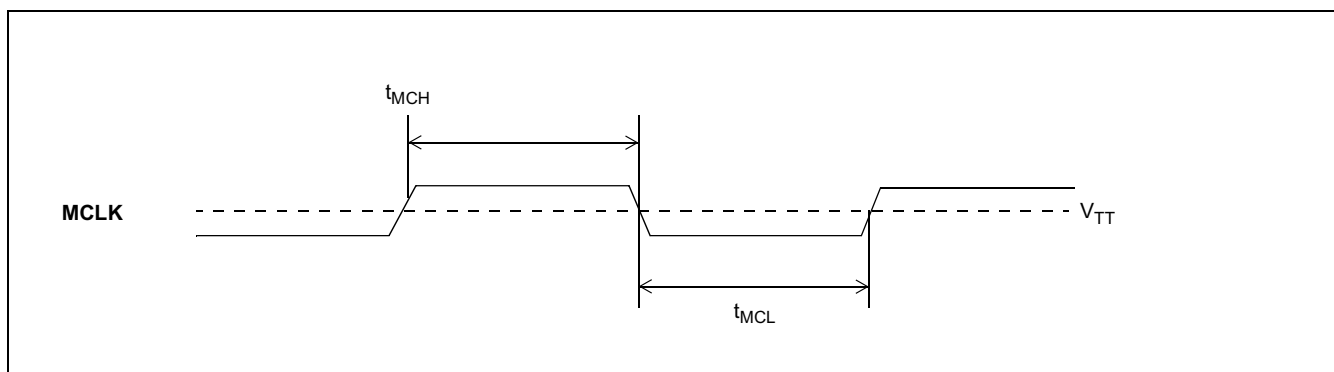

Figure 13 - Master Clock

**AC Electrical Characteristics† - Motorola Non-Multiplexed Bus Mode**

	Characteristics	Sym	Min	Typ‡	Max	Units	Test Conditions
1	$\overline{CS}$ setup from DS falling	$t_{CSS}$	0			ns	
2	R/W setup from DS falling	$t_{RWS}$	0			ns	
3	Address setup from DS falling	$t_{ADS}$	0			ns	
4	$\overline{CS}$ hold after DS rising	$t_{CSH}$	0			ns	
5	R/W hold after DS rising	$t_{RWH}$	0			ns	
6	Address hold after DS rising	$t_{ADH}$	0			ns	
7	Data delay on read	$t_{DDR}$			79	ns	$C_L=150pF, R_L=1K$
8	Data hold on read	$t_{DHR}$	3		15	ns	$C_L=150pF, R_L=1K$ See Note 1
9	Data setup on write	$t_{DSW}$	0			ns	
10	Data hold on write	$t_{DHW}$	0			ns	
11	Acknowledgment delay	$t_{AKD}$			80	ns	$C_L=150pF, R_L=1K$
12	Acknowledgment hold time	$t_{AKH}$	0		8	ns	$C_L=150pF, R_L=1K,$ See Note 1
13	$\overline{IRQ}$ delay	$t_{IRD}$	20		65	ns	$C_L=150pF, R_L=1K,$ See Note 1

† Characteristics are over recommended operating conditions unless otherwise stated

‡ Typical figures are at 25°C,  $V_{DD1}=3.3V$  and for design aid only: not guaranteed and not subject to production testing

\* Note 1: High Impedance is measured by pulling to the appropriate rail with  $R_L$ , with timing corrected to cancel time taken to discharge  $C_L$ .

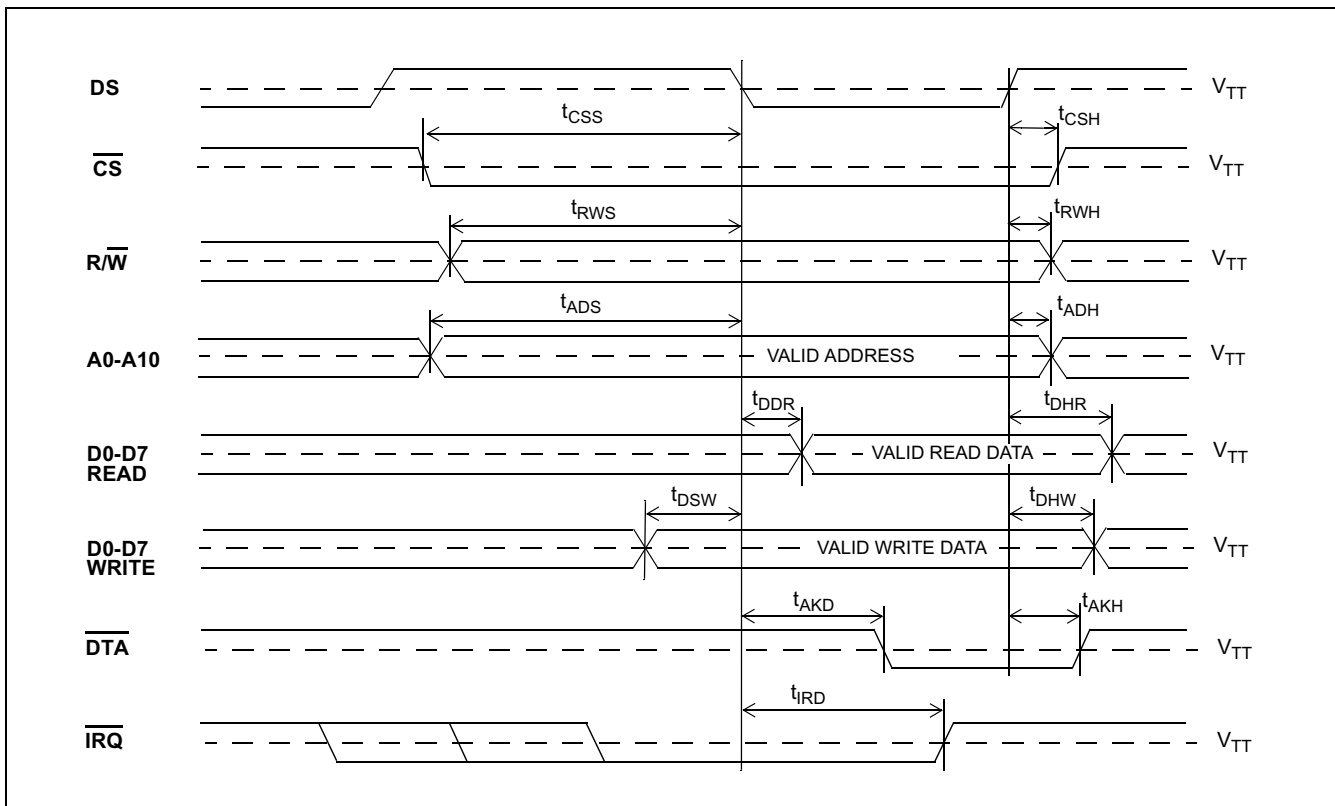
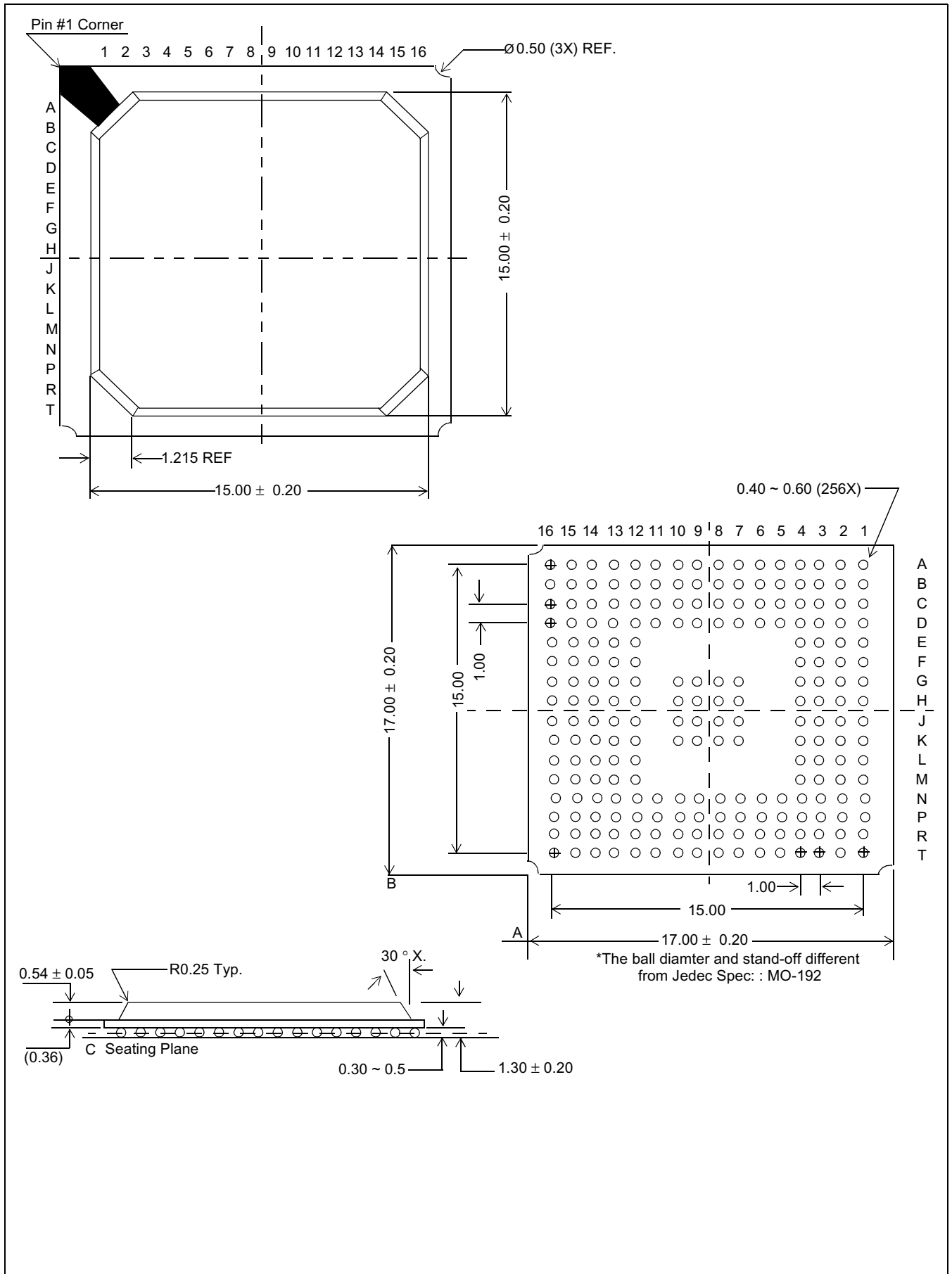
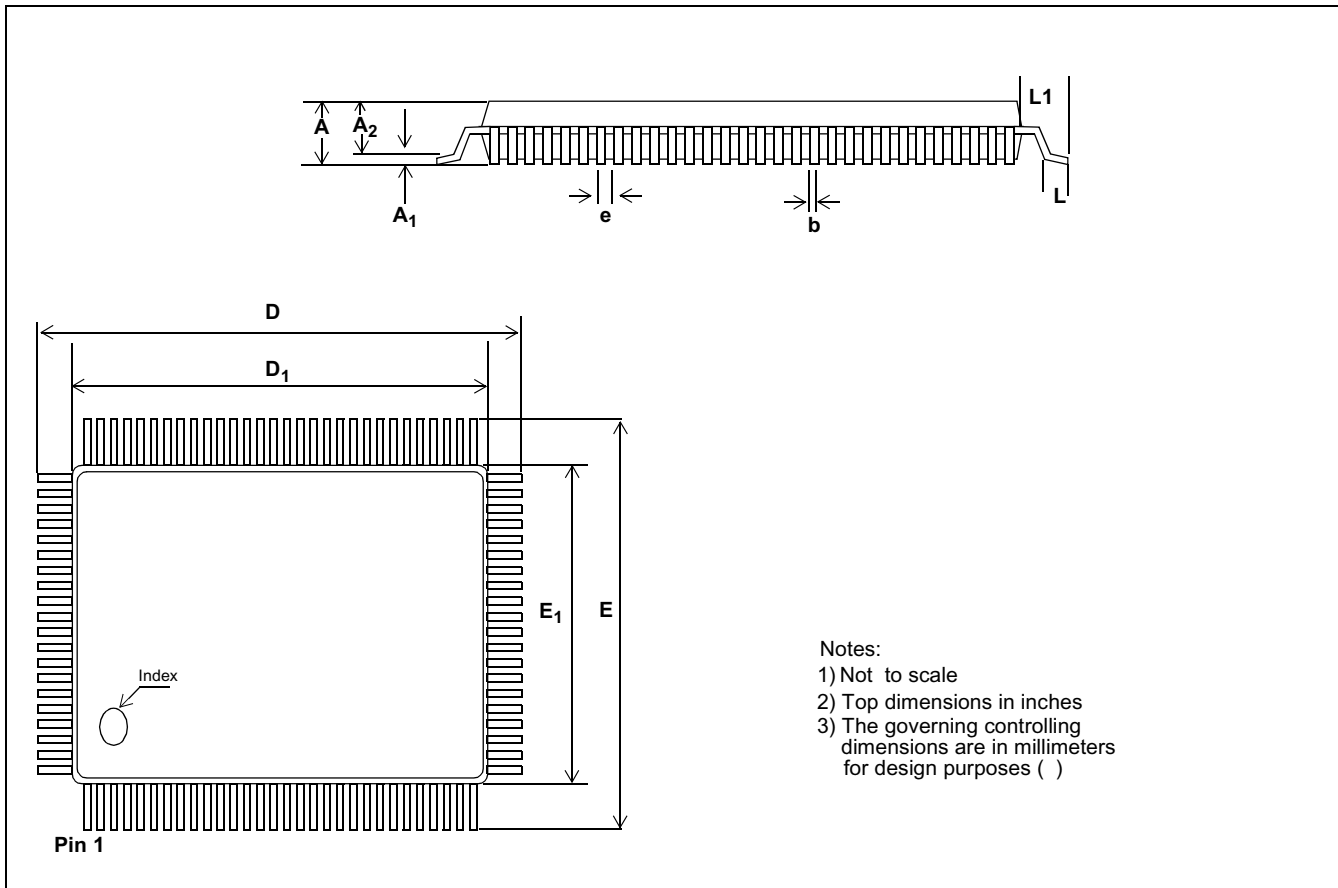

Figure 14 - Motorola Non-Multiplexed Bus Timing



208-Ball LPGA - V-suffix



160 Pin Metric Quad Flat Pack (MQFP) - L Suffix

Dim	160-Pin	
	Min	Max
A	-	0.154 (4.10)
A1	0.01 (0.25)	
A2	0.125 (3.17)	0.144 (3.67)
b	0.009 (0.22)	0.015 (0.38)
D	1.23 BSC (31.2 BSC)	
D <sub>1</sub>	1.102 BSC (28.00 BSC)	
E	1.23 BSC (31.2 BSC)	
E <sub>1</sub>	1.102 BSC (28.00 BSC)	
e	0.025 BSC (0.65 BSC)	
L	0.029 (0.73)	0.04 (1.03)
L1	0.063 REF (1.60 REF)	

NOTE: Governing controlling dimensions in parenthesis ( ) are in millimeters.





<http://www.zarlink.com>

**World Headquarters - Canada**

Tel: +1 (613) 592 0200

Fax: +1 (613) 592 1010

**North America - West Coast**

Tel: (858) 675-3400

Fax: (858) 675-3450

**North America - East Coast**

Tel: (978) 322-4800

Fax: (978) 322-4888

**Asia/Pacific**

Tel: +65 333 6193

Fax: +65 333 6192

**Europe, Middle East,  
and Africa (EMEA)**

Tel: +44 (0) 1793 518528

Fax: +44 (0) 1793 518581

Information relating to products and services furnished herein by Zarlink Semiconductor Inc. trading as Zarlink Semiconductor or its subsidiaries (collectively "Zarlink") is believed to be reliable. However, Zarlink assumes no liability for errors that may appear in this publication, or for liability otherwise arising from the application or use of any such information, product or service or for any infringement of patents or other intellectual property rights owned by third parties which may result from such application or use. Neither the supply of such information or purchase of product or service conveys any license, either express or implied, under patents or other intellectual property rights owned by Zarlink or licensed from third parties by Zarlink, whatsoever. Purchasers of products are also hereby notified that the use of product in certain ways or in combination with Zarlink, or non-Zarlink furnished goods or services may infringe patents or other intellectual property rights owned by Zarlink.

This publication is issued to provide information only and (unless agreed by Zarlink in writing) may not be used, applied or reproduced for any purpose nor form part of any order or contract nor to be regarded as a representation relating to the products or services concerned. The products, their specifications, services and other information appearing in this publication are subject to change by Zarlink without notice. No warranty or guarantee express or implied is made regarding the capability, performance or suitability of any product or service. Information concerning possible methods of use is provided as a guide only and does not constitute any guarantee that such methods of use will be satisfactory in a specific piece of equipment. It is the user's responsibility to fully determine the performance and suitability of any equipment using such information and to ensure that any publication or data used is up to date and has not been superseded. Manufacturing does not necessarily include testing of all functions or parameters. These products are not suitable for use in any medical products whose failure to perform may result in significant injury or death to the user. All products and materials are sold and services provided subject to Zarlink Semiconductor's conditions of sale which are available on request.

Purchase of Zarlink's I<sup>2</sup>C components conveys a licence under the Philips I<sup>2</sup>C Patent rights to use these components in an I<sup>2</sup>C System, provided that the system conforms to the I<sup>2</sup>C Standard Specification as defined by Philips

Zarlink and the Zarlink Semiconductor logo are trademarks of Zarlink Semiconductor Inc.  
Copyright 2001, Zarlink Semiconductor Inc. All rights reserved.

TECHNICAL DOCUMENTATION - NOT FOR RESALE