



M I C R O T U N E ®

MT2131 SINGLE-CHIP TERRESTRIAL TUNER

PRODUCT BRIEF

The MT2131 is a high-performance single-chip tuner for ATSC and Digital Cable-Ready ATSC television receivers and set-top boxes.



MT2131 Single-Chip Tuner

PRELIMINARY

RF SILICON AND SUBSYSTEMS SOLUTIONS
FOR BROADBAND COMMUNICATIONS AND AUTOMOTIVE ELECTRONICS

The MicroTuner™ MT2131 is an advanced single-chip terrestrial tuner, optimized for integrated digital televisions and ATSC set-top boxes.

The MT2131 receives frequencies in the 48 MHz to 1 GHz range and converts a selected channel to a standard intermediate frequency (IF) between 30 MHz and 57 MHz.

The MT2131's dual-conversion architecture yields consistent ATSC A/74 and FCC Digital Cable-Ready (DCR) compliant performance without any manual adjustments. This is achieved via the combination of MicroTune's ClearTune technology and an autonomous automatic gain control (AGC).

The integrated LNA delivers excellent sensitivity. The innovative gain control and power detector circuits provide superb terrestrial performance.

The MT2131 has an on-chip amplifier for Forward Data Channel (FDC) applications to reduce the total Bill of Materials (BOM) cost for a DCR television receiver. It supports multiple standards including ATSC, QAM, and NTSC. In addition, the MT2131 provides excellent in-band flatness, as well as consistent gain characteristics across the complete reception band for use in digital/analog televisions, terrestrial set-top boxes and high-performance PC-TV applications.

APPLICATIONS

- NTSC/ATSC front-ends
- ATSC-only front-ends and set-top boxes
- Digital Cable-Ready (DCR) ATSC integrated digital televisions
- ATSC PVRs
- PC-TVs
- DVD recorders

FEATURES

- 48 MHz to 1 GHz input frequency range
- Integrated front-end bandpass filtering
- Integrated RF power detectors and closed-loop AGC
- Programmable RF AGC
- Single-ended RF input
- On-chip low-noise amplifier provides excellent terrestrial sensitivity
- Integrated IF variable gain amplifier for direct connection to digital demodulators
- Fully compatible with ATSC, QAM, and NTSC performance requirements.
- Integrated FDC low-pass filter and buffer amplifier
- Capable of driving multiple IF filters
- Compatible with 3.3 V and 5 V serial bus
- 48 pin, 7 mm X 7 mm QFN package

M I C R O T U N E

MT2131 SINGLE-CHIP TERRESTRIAL TUNER
PRODUCT BRIEF

RECOMMENDED OPERATING CONDITIONS

PARAMETER	MIN	TYP	MAX	UNIT
Second intermediate center frequency (programmable)	30		57	MHz
Supply voltage 5V	4.75	5.0	5.25	V
Supply voltage 3.3V	3.15	3.3	3.45	V
Supply voltage ripple			15	mV
Operating junction temperature			125	°C
VGA output load impedance	300			Ω
Serial control clock			400	kHz

ABSOLUTE RATINGS

PARAMETER	MIN	MAX	UNIT
Supply voltage 5V		6	V
Supply voltage 3.3V		3.6	V
Storage temperature range	-50	+150	°C
Lead-free temperature (soldering 4 seconds)		+260	°C
Input voltage	-0.3	VCC +0.3	V

TUNER ELECTRICAL CHARACTERISTICS

PARAMETER	MIN	TYP	MAX	UNIT
Power Supply				
Active current 5V		240		mA
Active current 3.3V		95		mA
RF Signal Path				
Input frequency range	48		1000	MHz
Noise figure (Off-Air mode)		6		dB
Voltage gain		42		dB
RF AGC range		55		dB
Image rejection		70		dBc
LO phase noise (10 kHz)		84		dBc/Hz
LO phase noise (100 kHz)		104		dBc/Hz
LO step size		50		kHz
IF VGA				
Frequency range	30		57	MHz
Maximum output voltage			2.0	Vp-p
Maximum voltage gain		60		dB
IF AGC range		46		dB
Out-of-Band Amplifier (FDCA)				
Frequency range	50		130	MHz
Maximum voltage gain		12		dB
Supply current 5V		30		mA

PRELIMINARY

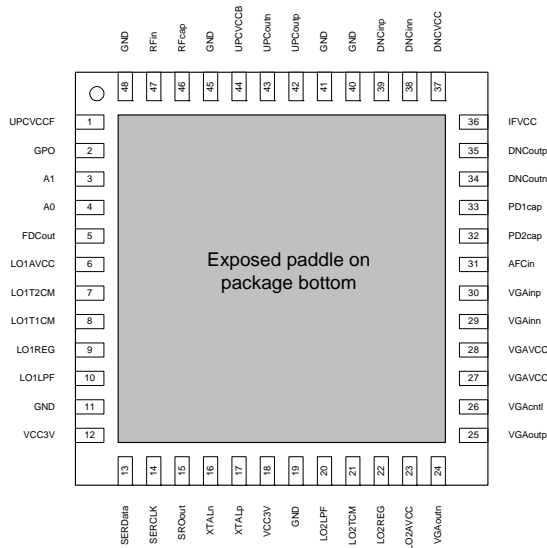

MT2131 Pin Diagram

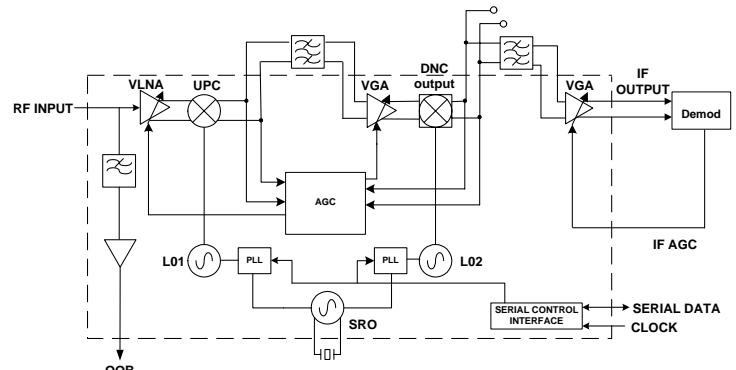

MT2131 Block Diagram



Microtune, Inc., 2201 Tenth Street, Plano, TX 75074, USA

Tel: +1-972-673-1600, Fax: +1-972-673-1602, E-mail: sales@microtune.com, Web site: www.microtune.com

For a detailed list of office centers, sales offices, and sales representatives, visit our Web site at www.microtune.com

The information in this document is believed to be accurate and reliable. Microtune assumes no responsibility for any consequences arising from the use of this information, nor from any infringement of patents or the rights of third parties which may result from its use. No license is granted by implication or otherwise under any patent or other rights of Microtune. The information in this publication replaces and supersedes all information previously supplied, and is subject to change without notice. The customer is responsible for assuring that proper design and operating safeguards are observed to minimize inherent and procedural hazards. Microtune assumes no responsibility for applications assistance or customer product design.

The devices described in this document are not authorized for use in medical, life-support equipment, or any other application involving a potential risk of severe property or environmental damage, personal injury, or death without prior express written approval of Microtune. Any such use is understood to be entirely at the user's risk.

Microtune is a registered trademark of Microtune, Inc. MicroTuner, MicroStreamer, VideoCaster, DataCaster, and the Microtune logo are trademarks of Microtune, Inc. All other trademarks belong to their respective companies.

Microtune's products are protected by one or more of the following U.S. patents: 5,625,325; 5,648,744; 5,717,730; 5,737,035; 5,739,730; 5,805,988; 5,847,612; 6,100,761; 6,104,242; 6,144,402; 6,163,684; 6,169,569; 6,172,378; 6,177,964; 6,211,745; 6,218,899; 6,268,778; 6,310,387; 6,323,736; 6,355,537; 6,429,502; 6,462,327; D469,742; 6,535,068; 6,580,313; 6,608,522; 6,631,257; 6,674,409; 6,714,776; 6,725,463; 6,744,308 B1; 6,771,124; 6,784,945; 6,804,099; 6,888,406; 6,891,435; 6,906,594; 6,920,182; 6,963,478; 6,973,288; D,469,742; DE10,011,662 and additional patents pending or filed.