

IT 3057-XXC Waterproof Cable Clamp for Jacketed Cable or Wires Protected by Tubing

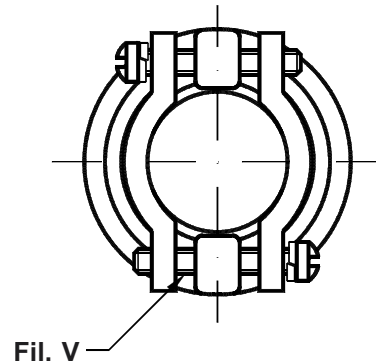

Application Notes:

1. Waterproof cable clamp suitable for jacketed cable or wires protected by tubing. Assures watertight integrity of connector.
2. Standard materials configuration consists of aluminum alloy with cadmium olive drab finish.
3. Other types of front and rear connector accessories are available.
See our website and/or contact the factory for complete information.

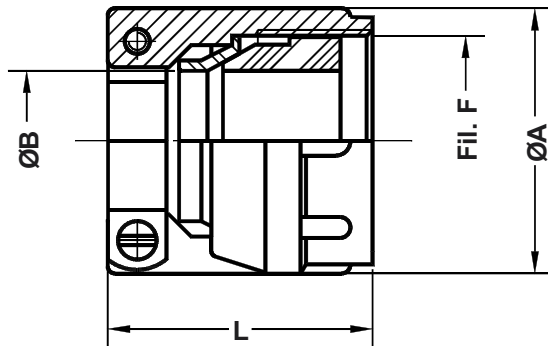
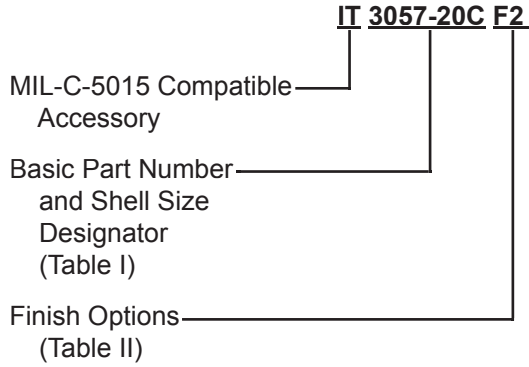

IT 3057-XXC
Waterproof Cable Clamp
 for Jacketed Cable or Wires Protected by Tubing



TABLE I: CABLE CLAMP PART NUMBERS, SHELL SIZE, SLEEVING, DIMENSIONS & THREAD

Part Number	Shell Size	Sleeve to Use	A	B		F Thread	L	V Thread
				min.	Max.			
IT 3057- 4C	10 SL	IT 3420 - 4A	22.6	2.38	7.93	0.6250 - 24UNEF	32.3	6 - 32NC
IT 3057- 6C	14 S	IT 3420 - 4A / 6A	25.8	5.84	11.12	0.7500 - 20UNEF	32.3	6 - 32NC
IT 3057- 8C	16 S - 16	IT 3420 - 6A / 8A	28.1	8.00	13.48	0.8750 - 20UNEF	32.3	6 - 32NC
IT 3057-10C	18	IT 3420 - 6A / 10A	31.0	9.60	15.87	1.0000 - 20UNEF	35.3	6 - 32NC
IT 3057-12C	20 - 22	IT 3420 - 8A / 12A	37.3	11.30	19.00	1.1875 - 18UNEF	35.7	8 - 32NC
IT 3057-16C	24 - 28	IT 3420 - 8A / 12A / 16A	42.0	15.50	23.80	1.4375 - 18UNEF	38.5	8 - 32NC
IT 3057-20C	32	IT 3420 - 12A / 16A / 20A	54.0	23.40	31.75	1.7500 - 18UNS	44.8	250 - 20NC
IT 3057-24C	36	IT 3420 - 16A / 18A / 24A	57.1	23.40	35.00	2.0000 - 18UNS	51.6	250 - 20NC
IT 3057-28C	40	IT 3420 - 16A / 20A / 28A	63.5	29.90	41.25	2.2500 - 16UN	51.6	250 - 20NC

TABLE II: MODIFICATION CODES

FINISH OPTIONS	
Sym	Description
F2	Bright Nickel Plating
F6	Black Electrodeposited Paint
F7	Black Zn-Co Plating
F8	Olive Drab Zn-Co Plating
Omit for standard version (see note 2)	

