



M I C R O T U N E ®

## MT1503EDC DAB/DMB TUNER

### PRODUCT BRIEF

The MT1503EDC is a high-end tuner module with integrated channel decoding and baseband processing capabilities for terrestrial digital audio broadcasting (DAB). It has been designed to meet the specific requirements of automotive applications.



MT1503EDC DAB/DMB Tuner

RF SILICON AND SUBSYSTEMS SOLUTIONS  
FOR BROADBAND COMMUNICATIONS AND AUTOMOTIVE ELECTRONICS

The MT1503EDC is a tuner module for reception in VHF Band III and L-Band compliant to the DAB EUREKA 147 standard. It performs a down-conversion to an intermediate frequency followed by further signal processing based on an integrated baseband processor. A serial bus interface serves as a digital audio output.

In order to minimize interferences and distortion caused by undesired signals of adjacent channels the tuner section of the MT1503 features digitally aligned tracking filters and an IF SAW filter. The integrated flash memory stores the necessary alignment data and the software for the baseband processor.

The MT1503EDC supports a variety of possible applications by decoding FIC/FIDC and PAD data which is used to broadcast dynamic labels, traffic information, slideshows, websites as well as information needed for station following and announcement switching. A standardized Raw Data Interface (RDI) and a Serial Peripheral Interface (SPI) grant access to the full DAB audio and data stream to enable an easy connection of external decoders for additional data services and mobile TV applications. All tuner and DSP functions are controlled by a Universal Synchronous/Asynchronous Receiver/Transmitter (USART) interface.

Active antenna systems as commonly used for automotive applications can be fed with 12V phantom power which is routed from a pin connector to the antenna input of the module.

The MT1503EDC is lead free and fully complies with RoHS requirements. It has been optimized

to meet the specific requirements for automotive applications and provides reliable performance even under harsh environmental conditions like temperatures from  $-40^{\circ}\text{C}$  to  $+85^{\circ}\text{C}$ .

### APPLICATIONS

- High-end automotive entertainment systems featuring digital audio (DAB) or video services (DMB, DAB-IP)
- Dynamic navigation systems requiring TMC or TPEG data
- Information terminals for mobile data services

### FEATURES

- Double down-conversion for L-Band, Single down-conversion for VHF Band III reception
- $50\ \Omega$  antenna input matching
- External RF AGC (pin diode)
- Gain controlled LNAs for both bands
- Selectable RF AGC threshold level
- Tunable preselection filter for better image rejection
- IF SAW filter
- Selectable IF AGC threshold
- Decoding of full DAB audio/data stream according to EUREKA 147 standard
- Decoding of FIC/FIDC and PAD data
- Processing of data services in parallel to audio service
- Supports stream and packet mode
- Error concealment and dropout masking
- Extended data processing capabilities
- Very small form factor
- Shielded metal housing
- USART bus for control functions
- RDI and SPI interfaces for external DMB and data decoders
- USB and SSO interface optional
- Extended parametric temperature range of  $-40^{\circ}$  to  $+85^{\circ}\text{C}$
- 12 V phantom power feeding for an active antenna
- On-board flash memory
- Lead free and RoHS compliant
- Qualified according to automotive requirements

OPERATING CHARACTERISTICS

PARAMETER	MIN	TYP	MAX	UNIT
1.8 V Power Supply Voltage				
Current VHF Band III Mode		85		mA
Current L-Band Mode		140		mA
3.3 V Power Supply Voltage				
Current VHF Band III Mode		165		mA
Current L-Band Mode		200		mA
12 V Power Supply Voltage (Phantom Feeding)				
Current			130	mA
Temperature Characteristics				
Operating Temperature	-40		+85	°C
Storage temperature	-40		+95	°C

ELECTRICAL CHARACTERISTICS

PARAMETER	MIN	TYP	MAX	UNIT
VHF Band III characteristics:				
Receiving frequency range	174.928		239.200	MHz
Maximal input level		0		dBm
Sensitivity at 25°C		-98		dBm
Selectivity		37		dB
Far off Selectivity		48		dB
L-Band characteristics:				
Receiving frequency range	1452.816		1491.184	MHz
Maximal input level		0		dBm
Sensitivity at 25°C		-96		dBm
Selectivity		37		dB
Far off Selectivity		48		dB

MECHANICAL CHARACTERISTICS

PARAMETER	MIN	UNIT
Length	56	mm
Width	37	mm
Height	12	mm
Number of Pins	21	

INPUT/OUTPUT CHARACTERISTICS

PARAMETER	MIN	TYP	MAX	UNIT
Antenna Input 50 Ω (AGC not active)			4	VSWR
SPI bus				
Bus voltage high		3.3		V
Bus voltage low		0		V
Clock frequency	0		5	MHz
Serial audio output				
Bus voltage high		3.3		V
Bus voltage low		0		V
RDI data output				
Logical Voltage High		3.3		V
Logical Voltage Low		0		V
Data rate		1.8432		Mbit/s
USART interface (RD232)				
Logical Voltage High		3.3		V
Logical Voltage Low		0		V
ARM7 watchdog overflow				
Logical Voltage High		1.8		V
Logical Voltage Low		0		V
Interrupt Input				
Logical Voltage High		1.8		V
Logical Voltage Low		0		V
Reset				
Logical Voltage High		3.3		V
Logical Voltage Low		0		V
Chip select 0				
Logical Voltage High		3.3		V
Logical Voltage Low		0		V
Chip select 1				
Logical Voltage High		1.8		V
Logical Voltage Low		0		V
Chip select 2				
Logical Voltage High		1.8		V
Logical Voltage Low		0		V

PRELIMINARY

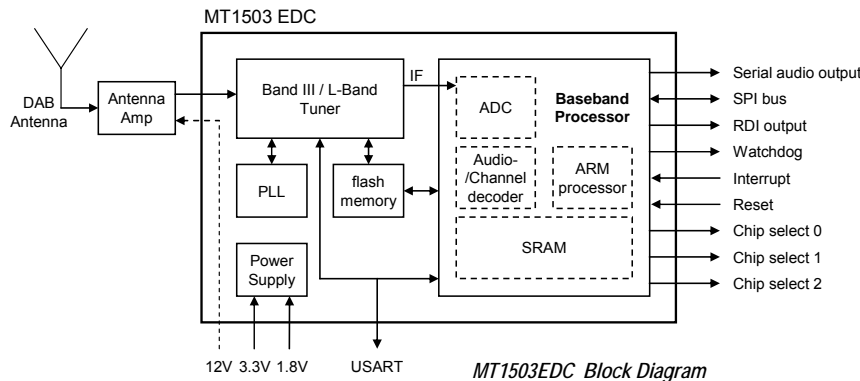

MicroTune, Inc., 2201 Tenth Street, Plano, TX 75074, USA

Tel: +1-972-673-1600, Fax: +1-972-673-1602, E-mail: sales@microtune.com, Web site: [www.microtune.com](http://www.microtune.com)

For a detailed list of office locations, sales offices, and sales representatives, visit our Web site at [www.microtune.com](http://www.microtune.com)

The information in this document is believed to be accurate and reliable. MicroTune assumes no responsibility for any consequences arising from the use of this information, nor from any infringement of patents or the rights of third parties which may result from its use. No license is granted by implication or otherwise under any patent or other rights of MicroTune. The information in this publication replaces and supersedes all information previously supplied, and is subject to change without notice. The customer is responsible for assuring that proper design and operating safeguards are observed to minimize inherent and procedural hazards. MicroTune assumes no responsibility for applications assistance or customer product design.

The devices described in this document are not authorized for use in medical, life-support equipment, or any other application involving a potential risk of severe property or environmental damage, personal injury, or death without prior express written approval of MicroTune. Any such use is understood to be entirely at the user's risk.

MicroTune is a registered trademark of MicroTune, Inc. MicroTuner, MicroStreamer, VideoCaster, DataCaster, ClearTune, and the MicroTune logo are trademarks of MicroTune, Inc. All other trademarks belong to their respective companies.

MicroTune's products are protected by one or more of the following U.S. patents: 5,625,325; 5,648,744; 5,717,730; 5,737,035; 5,739,730; 5,805,988; 5,847,612; 6,100,761; 6,104,242; 6,163,684; 6,169,569; 6,172,378; 6,177,964; 6,211,745; 6,218,899; 6,268,778; 6,310,387; 6,323,736; 6,355,537; 6,429,502; 6,462,327; 6,535,068; 6,580,313; 6,608,522; 6,631,257; 6,714,776; 6,725,463; 6,744,308; 6,771,124; 6,784,945; 6,804,099; 6,888,406; 6,891,435; 6,906,594; 6,909,886; 6,919,774; 6,920,182; 6,922,556; 6,963,478; 6,973,288; 6,993,310; 7,035,614; 7,078,960; 7,079,195; 7,164,899; 7,171,176; 7,184,724; D469,742 and additional patents pending or filed.

Entire contents Copyright © 1996 - 2007 MicroTune, Inc.

030207