

# RADIAL LEAD TANGOLD™ CAPACITORS

## EPOXY RESIN COATED, TANTALUM

# TR SERIES



- Epoxy resin dipped, UL94V-0 Flame Retardant
- Low leakage current and impedance
- Excellent humidity and heat resistance
- Laser marked capacitor body
- Several lead-wire forms available

### STANDARD LEAD STYLES

Style 10 (.100" lead spacing)    Style 20 (.200" lead spacing)

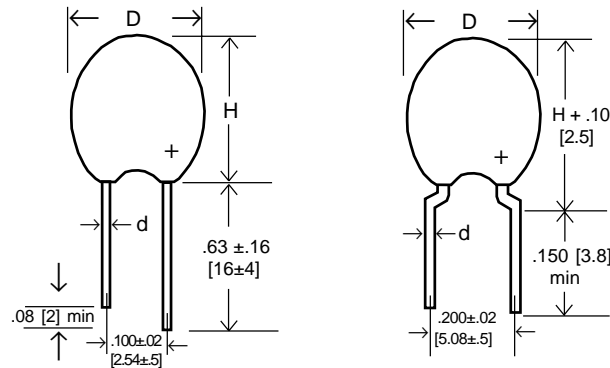

### OPTIONAL LEAD STYLES (additional styles available)

Style 25 (.250" lead spacing)    Style 10K (.100" LS with kink)

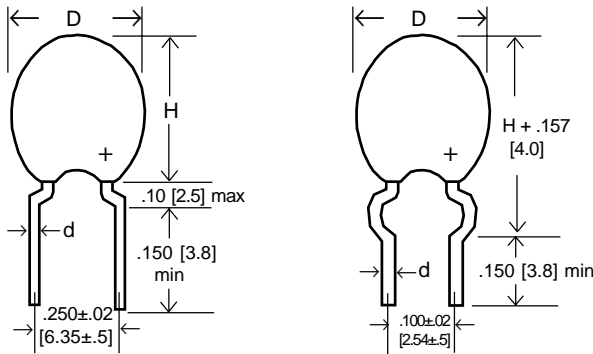

### P/N DESIGNATION:

**TR A 10 □ - 105 - K 020 A W**

RCD Type **TR**  
 Case Code: A, B, C, D, E, F **A**  
 Lead Style: 10, 20, 25, 10K, etc. **10**  
 Option Code(s): Leave blank if standard **□**  
 Capacitance Code (pF): 2 significant digits & multiplier **105**  
 Tolerance: Standard=K (10%). J (5%) & M (20%) also avail. **K**  
 Voltage: 3 digit code (003=3V, 004=4V, 006=6.3V, 010=10V, 016=16V, 020=20V, 025=25V, 035=35V, 050=50V) **020**  
 Packaging: B=Bulk, A = Ammo (tape & box) **A**  
 Termination: W= Lead-free (std), Q= Tin/Lead (leave blank if either is acceptable) **W**

### DIMENSIONS

Case Size	D(Max)	H (Max)	d ± .002 [.05]
A	.177 [4.5]	0.28 [7.1]	.020 [0.50]
B	.196 [5.0]	.315 [8.0]	.020 [0.50]
C	.217 [5.5]	.375 [9.5]	.020 [0.50]
D	.256 [6.5]	.433 [11.0]	.020 [0.50]
E	.335 [8.5]	.512 [13.0]	.020 [0.50]
F	.375 [9.5]	.650 [16.5]	.020 [0.50]

RATED VOLTAGE, NOMINAL CAPACITANCE AND CASE SIZES									
Rated DC Voltage(85°C)	3	4	6.3	10	16	20	25	35	50
Rated DC Voltage(125°C)	2	2.5	4	6.3	10	13	16	20	32
Short-time Overload Voltage (30Sec)	4	5.2	8	13	20	26	33	46	65
Capacitance (µF)	Code	Case Code							
0.047	473							A	A
0.068	683							A	A
0.1	104							A	A
0.15	154							A	A
0.22	224							A	A
0.33	334							A	A
0.47	474							A	A
0.68	684							A	A
1.0	105				A	A	A	A	B
1.5	155				A	A	A	A	C
2.2	225			A	A	A	A	B	C
3.3	335			A	A	A	B	B	D
4.7	475	A	A	A	A	B	B	B	D
6.8	685	A	A	A	B	B	C	C	D
10	106	A	A	B	B	B	C	C	E
15	156	A	A	B	C	C	D	D	F
22	226	B	B	C	C	C	D	D	F
33	336	B	B	C	D	D	E	E	F
47	476	C	C	D	D	D	E	E	F
68	686	D	D	D	D	E	F	F	
100	107	D	D	E	E	E	F	F	
150	157	D	E	E	E	F			
220	227	E	E	E	F				
330	337	E	F	F					
470	477	F							
680	687	F							

### SPECIFICATIONS

CAPACITANCE (µF)	ΔC FROM INITIAL LIMIT			DISSIPATION FACTOR (25°C, 120Hz)			
	-55°C	+85°C	+125°C	-55°C	+25°C	+85°C	+125°C
<1.0				6%	4%	6%	6%
1.5 to 68	±10%	±15%	±25%	10%	6%	10%	10%
100 to 680				12%	8%	12%	12%