

## 1.6GHz Low Noise Amplifier

### GENERAL DESCRIPTION

XC2404 series is an ultra-low-noise amplifier (LNA) with low operating voltage, low noise figure, low power consumption. The device offers easy output matching to 50  $\Omega$  for input and output with less external components.

The device operates at 1.2V. For higher power supplies such as 1.8V and 2.85V, the device can operate with a self bias of one adding resistor.

### APPLICATIONS

GPS band RF signal amplified

### FEATURES

Noise Figure	: NF=0.94dB(TYP.) @ 1.575GHz
Low Power Consumption	: 12.0mW(TYP.) @ $V_{DD}=1.2V$ , Fixed bias
High Gain	: $ S_{21} =26.5dB$ (TYP.) @ 1.575GHz
Operation Voltage Range	: 1.14V ~ 1.26V @ Fixed bias
Output	: CMOS Output, 50 $\Omega$ driver built-in
Operating Temperature Range	: -40 ~ +85
Ultra Small Package	: USP-8A01
Environmentally Friendly	: EU RoHS Compliant, Pb Free

### TYPICAL APPLICATION CIRCUIT

Figure 1: Fixed Bias

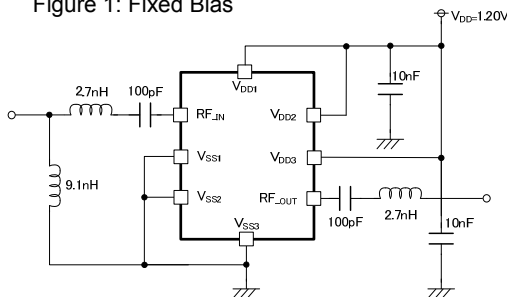
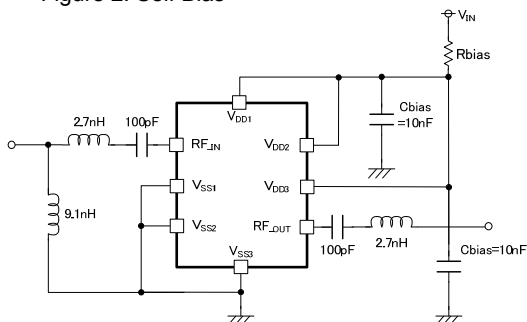

Figure 2: Self Bias



$V_{IN}$ [V]	$R_{BIAS}$ [ $\Omega$ ]
3.00	270
2.85	240
1.80	82

\*  $R_{BIAS}$  should be in  $\pm 1\%$  tolerance and  $\pm 200ppm/^\circ C$  temperature stability.  
 $C_{BIAS}$  is 10nF.

### TYPICAL PERFORMANCE CHARACTERISTICS

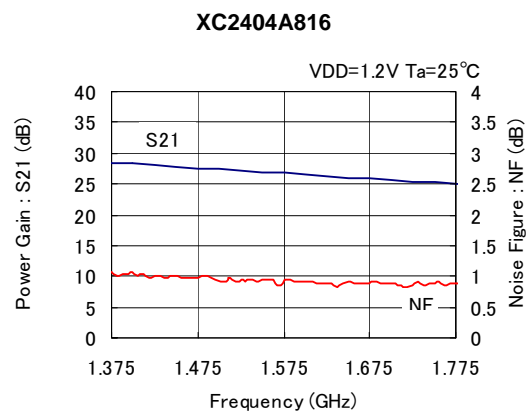

## PIN CONFIGURATION

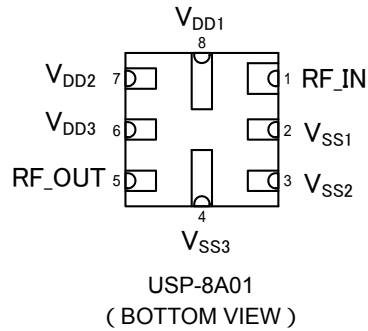

## PIN ASSIGNMENT

PIN NUMBER	PIN NAME	FUNCTION
USP-8A01		
1	RF_IN	RF Signal Input
2	V <sub>SS1</sub>	Ground
3	V <sub>SS2</sub>	Ground
4	V <sub>SS3</sub>	Ground
5	RF_OUT	RF Signal Output
6	V <sub>DD3</sub>	Power Supply
7	V <sub>DD2</sub>	Power Supply
8	V <sub>DD1</sub>	Power Supply

## PRODUCT CLASSIFICATION

### Ordering Information

XC2404A816 - <sup>(\*)</sup>

DESIGNATOR	DESCRIPTION	SYMBOL	DESCRIPTON
-	Packages Taping Type	UR-G	USP-8A01

<sup>(\*)</sup> The "-G" suffix indicates that the products are Halogen and Antimony free as well as being fully RoHS compliant.

## BLOCK DIAGRAMS

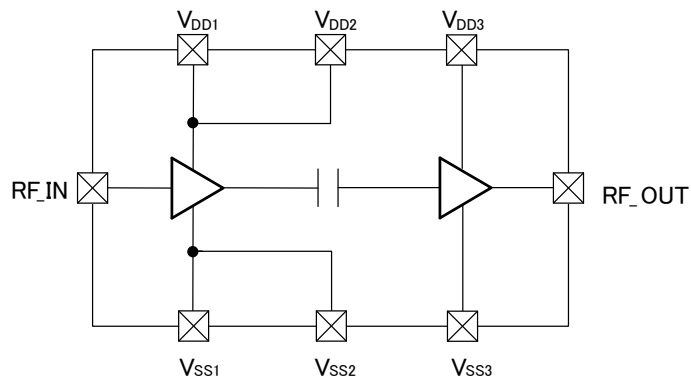

## ABSOLUTE MAXIMUM RATINGS

Ta=25			
PARAMETER	SYMBOL	RATINGS	UNITS
Supply Voltage	$V_{DD}$	1.60	V
Current Circuit	$I_{DD}$	42	mA
RF Input Power	$P_{IN}$	10	dBm
Power Dissipation	$P_d$	120	mW
Operating Temperature Range	$T_a$	-40 ~ +85	°C
Storage Temperature Range	$T_{stg}$	-55 ~ +125	°C

## ELECTRICAL CHARACTERISTICS

### DC Characteristics

Fixed Bias (refer to TYPICAL APPLICATION CIRCUIT, Figure 1)

Ta=25

PARAMETER	SYMBOL	CONDITIONS	MIN.	TYP.	MAX.	UNITS	CIRCUITS
Power Supply Pin Voltage	V <sub>DD</sub>	-	1.14	1.20	1.26	V	
Current Circuit	I <sub>DD</sub>	V <sub>DD</sub> =1.2V	4.00	10.0	18	mA	

Self Bias (refer to TYPICAL APPLICATION CIRCUIT, Figure 2)

Ta=25

PARAMETER	SYMBOL	CONDITIONS	MIN.	TYP.	MAX.	UNITS	CIRCUITS
Input Power Supply Voltage 1	V <sub>IN1</sub>	R <sub>BIAS</sub> =270 ± 1%, ± 200ppm/	2.850	3.000	3.150	V	
Input Power Supply Voltage 2	V <sub>IN2</sub>	R <sub>BIAS</sub> =240 ± 1%, ± 200ppm/	2.708	2.850	2.992	V	
Input Power Supply Voltage 3	V <sub>IN3</sub>	R <sub>BIAS</sub> =82 ± 1%, ± 200ppm/	1.710	1.800	1.890	V	
Power Supply Pin Voltage	V <sub>DD</sub>	V <sub>IN</sub> = V <sub>IN1</sub> , V <sub>IN2</sub> , V <sub>IN3</sub>	0.90	1.12	1.32	V	
Current Circuit	I <sub>DD</sub>	V <sub>IN</sub> = V <sub>IN1</sub> , V <sub>IN2</sub> , V <sub>IN3</sub>	5.25	7.25	11.0	mA	

\* When the device is used in self bias, please use the specified R<sub>BIAS</sub> and C<sub>BIAS</sub>.

## ELECTRICAL CHARACTERISTICS (Continued)

## AC Characteristics

 $V_{DD}=1.2V$ ,  $T_a=25$ 

PARAMETER	SYMBOL	CONDITIONS	MIN.	TYP.	MAX.	UNITS	CIRCUITS
Power Gain	S21	f=1.575GHz	24	26.5	-	dB	
Input Return Loss	S11	f=1.575GHz	-	10	-	dB	
Output Return Loss	S22	f=1.575GHz	-	17	-	dB	
Isolation	S12	f=1.575GHz	-	-36	-	dB	
Noise Figure <sup>(*)</sup>	NF	f=1.575GHz	-	0.94	-	dB	
Input Power IP3	$I_{IP3}$	f=1.575GHz, 1.576GHz	-	-14.5	-	dBm	
Input Power @ 1dB Gain Compression	P1dB	f=1.575GHz	-	-25.5	-	dBm	

\*1: NF is the value excluding the substrate loss.

## Note

- This series is structurally weak in electrostatic discharge.  
Please eliminate static electricity from the operational table, people, and soldering iron.
- Please use noiseless power supply for stable operation.
- Please use  $\pm 1\%$  Rbias with  $\pm 200\text{ppm}/^\circ\text{C}$  temperature stability and 10nF Cbias.
- Please connect Cbias to  $V_{DD}$  pin as close as possible.
- Please refer to the pattern layout.  $V_{DD}$  pins ( $V_{DD1}$ ,  $V_{DD2}$ ,  $V_{DD3}$ ) should be connected each other outside. Also,  $V_{SS}$  pins ( $V_{SS1}$ ,  $V_{SS2}$ ,  $V_{SS3}$ ) should be connected as well.
- Please ensure to use an external component which does not depend on bias or temperature too much.

## TEST CIRCUITS

Circuit ( DC Characteristics: Power Supply Pin Voltage, Circuit Current, Input Power Supply Voltage )

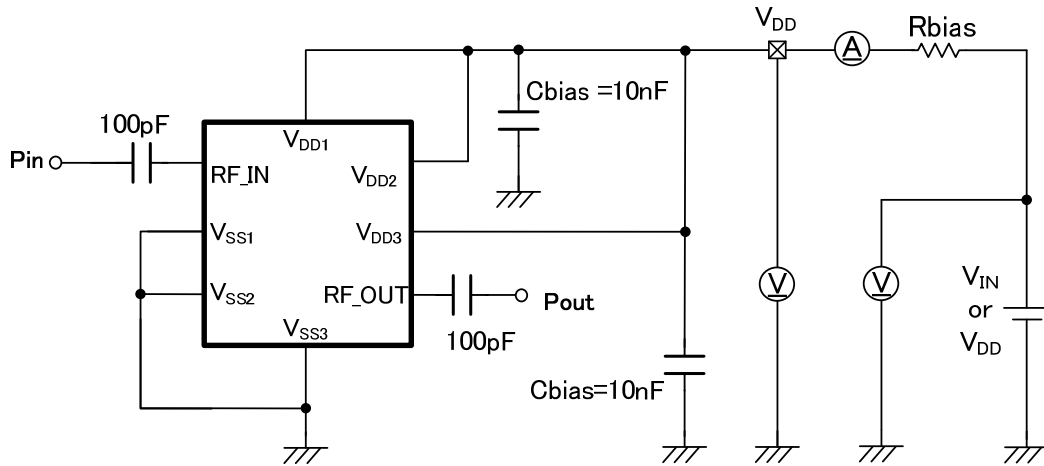

- \* Fixed Bias:  $R_{bias}=0\Omega$ ,  $V_{IN}=V_{DD}$
- \*\* Pin / Pout is  $50\Omega$

Circuit ( Power Gain, Input Return Loss, Output Return Loss, Isolation, Input Power @ 1dB Gain Compression )

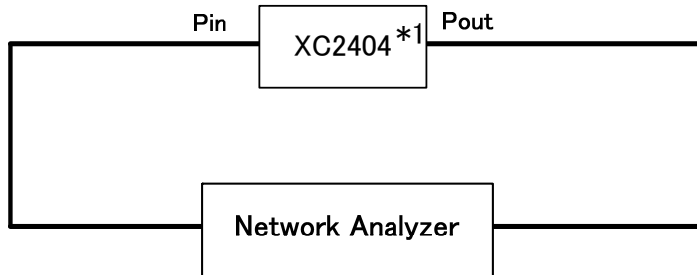

\*1: Refer to the circuit for the block detail.

Circuit ( Noise Figure )

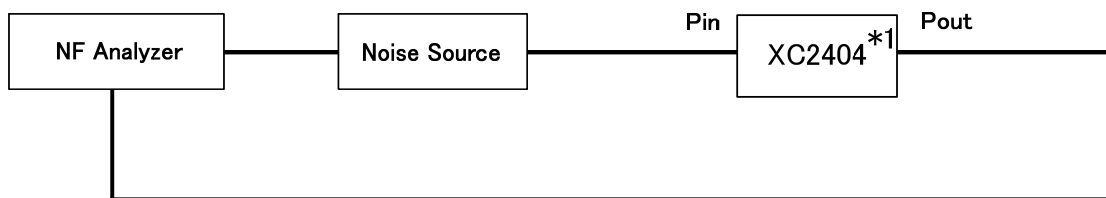

\*1: Refer to the circuit for the block detail.

## TEST CIRCUITS (Continued)

Circuit ( Input Power IIP3 )

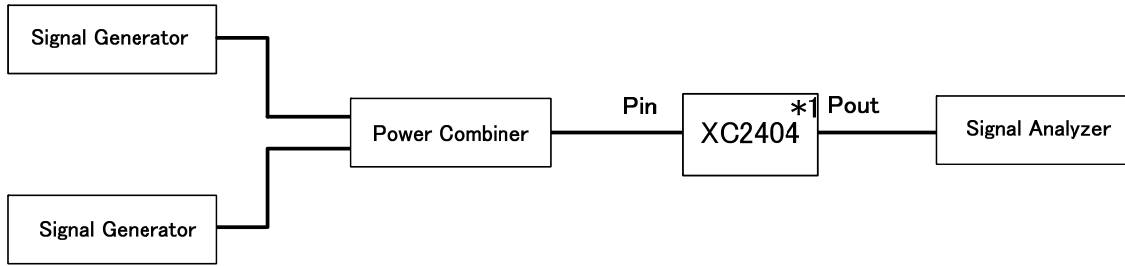

\*1: Refer to the circuit for the block detail.

Circuit ( XC2404 series, the circuit of the block )

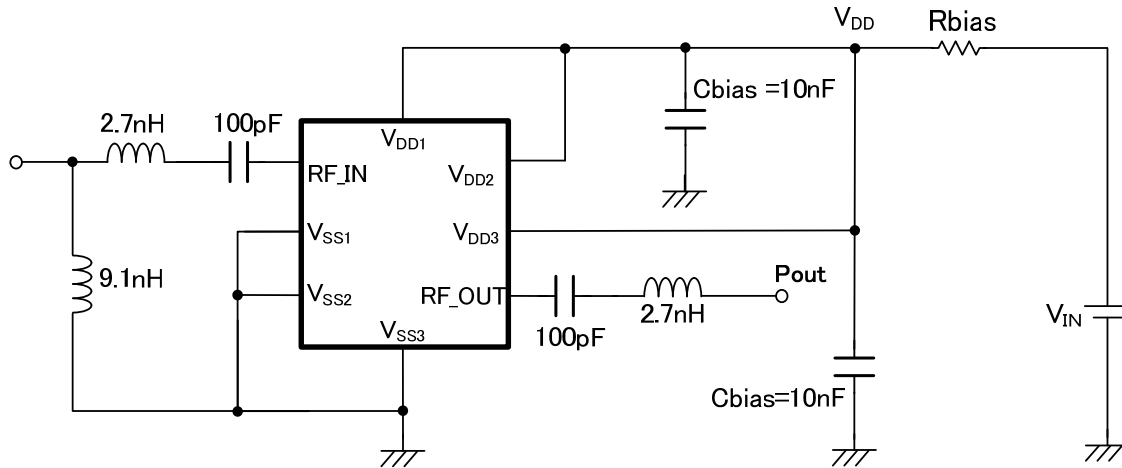

$V_{IN}(V)$	$R_{bias}(\Omega)$
3.00	270
2.85	240
1.80	82

- \* Fixed Bias:  $R_{bias}=0\Omega$ ,  $V_{IN}=V_{DD}$
- \*\*  $R_{bias}$ : Should be in  $\pm 1\%$  tolerance and  $\pm 200\text{ppm}/^\circ\text{C}$  temperature stability.  $C_{bias}$  is 10nF.
- \*\*\* Please refer to the EVALUATION BOARD layout.  $V_{DD}$  pin ( $V_{DD1}$ ,  $V_{DD2}$ ,  $V_{DD3}$ ) and  $V_{SS}$  pin ( $V_{SS1}$ ,  $V_{SS2}$ ,  $V_{SS3}$ ) are connected respectively on the board.

## EVALUATION BOARD

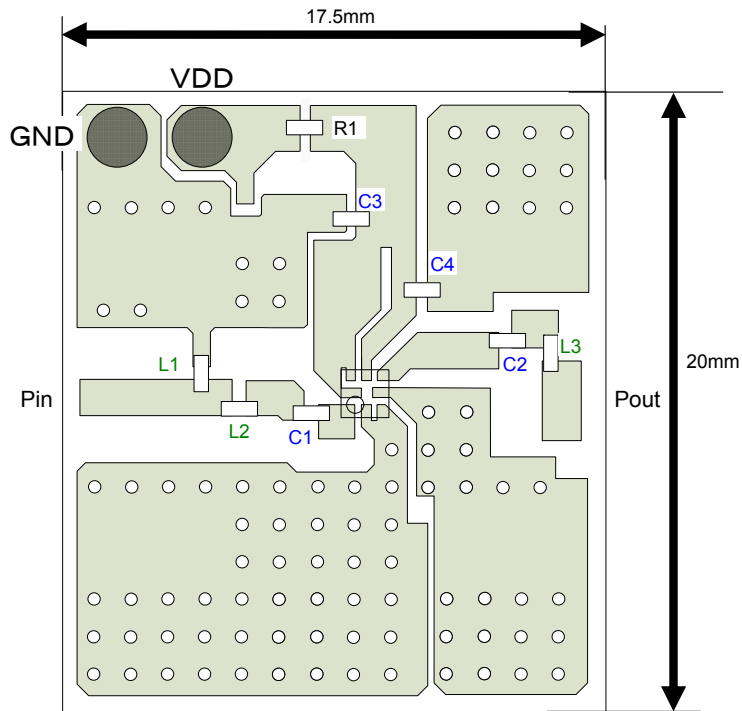

SYMBOL	SPEC	COMMENT
C1, C2	100pF	MURATA (GRM1552C1H)
C3,C4	10nF	-
L1	9.1nH	TAIYO YUDEN AQseries (AQ1059N1J)
L2,L3	2.7nH	TAIYO YUDEN AQseries (AQ1052N7J)
R1 (Rbias) <sup>(*)</sup>	- <sup>(*)</sup>	Less than $\pm 1\%$ tolerance, Less than $\pm 200\text{ppm/}$ temperature stability

PCB (FR-4)  
 MICROSTRIPLINE WIDTH =1.25mm  
 t=0.8mm  
 PCB size = 20mm x 17.5mm

\*1: Fixed Bias: Rbias=0

\* Please use an external component which does not depend on bias or temperature too much.



## TYPICAL PERFORMANCE CHARACTERISTICS

(1) Current Circuit vs. Supply Voltage

XC2404A816

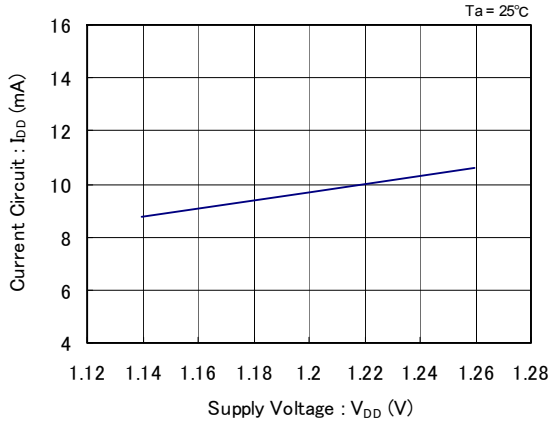

(2) Power Gain vs. Supply Voltage

XC2404A816

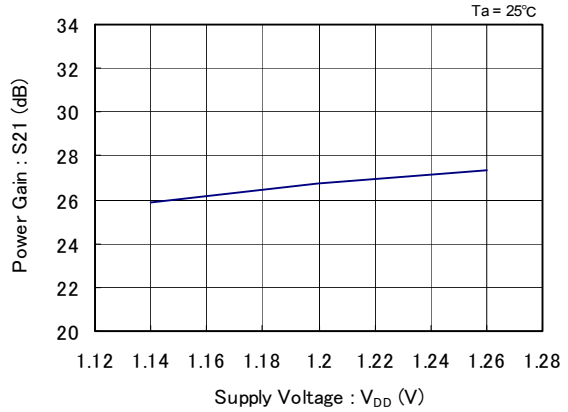

(3) Input Return Loss vs. Supply Voltage

XC2404A816

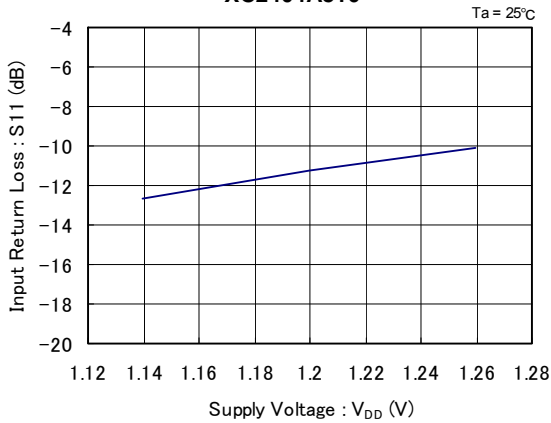

(4) Output Return Loss vs. Supply Voltage

XC2404A816

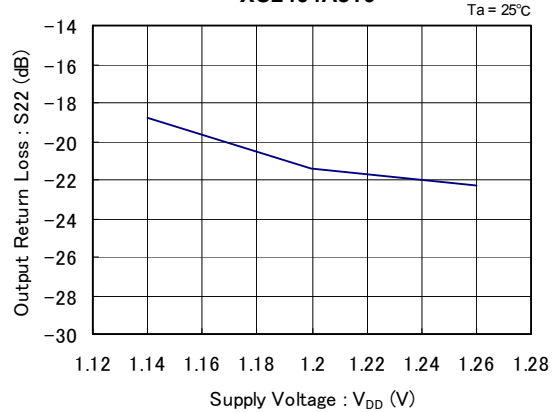

(5) Isolation vs. Supply Voltage

XC2404A816

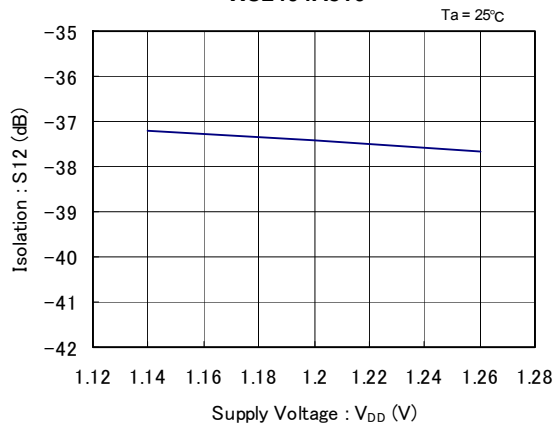

(6) Noise Figure vs. Supply Voltage

XC2404A816

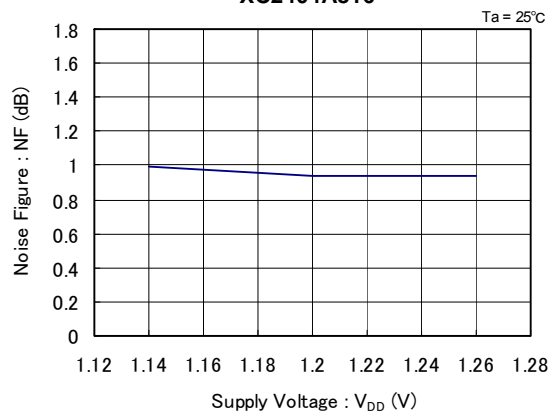

## TYPICAL PERFORMANCE CHARACTERISTICS (Continued)

(7) Input 3 Order Intercept Point vs. Supply Voltage

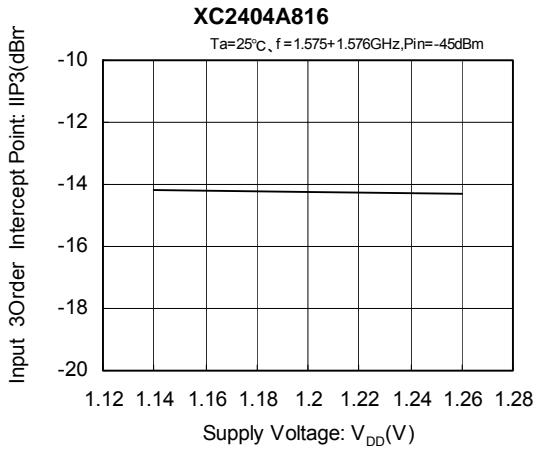

(8) Input Power @ 1dB Gain compression vs. Power Supply Voltage

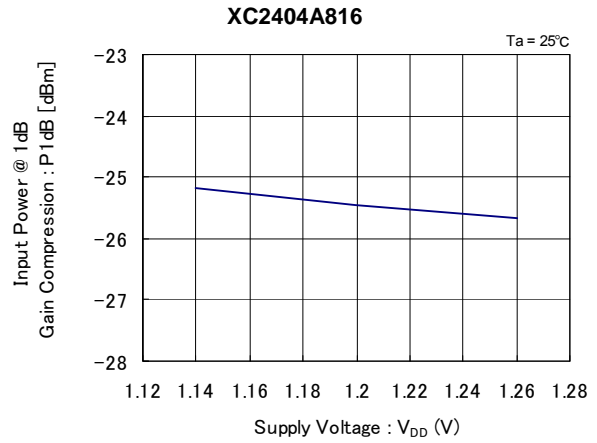

(9) Supply Current vs. Ambient Temperature

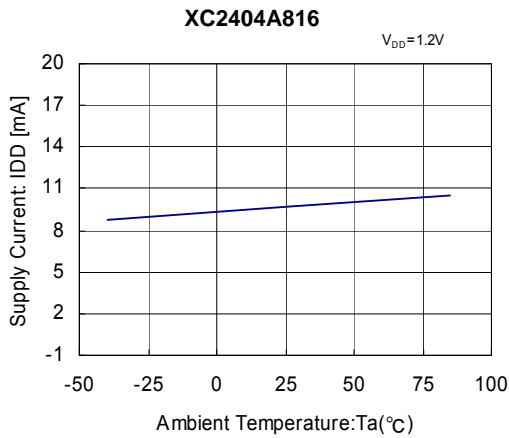

(10) Power Gain vs. Ambient Temperature

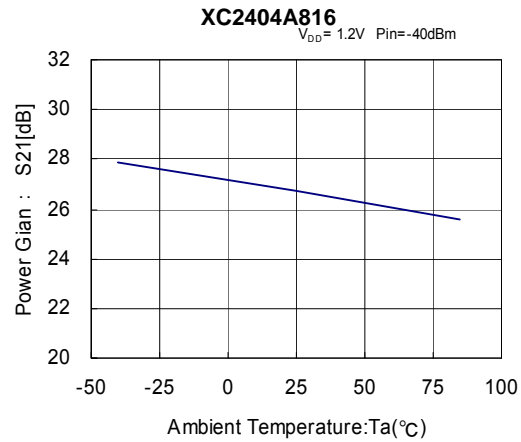

(11) Input Return Loss vs. Ambient Temperature

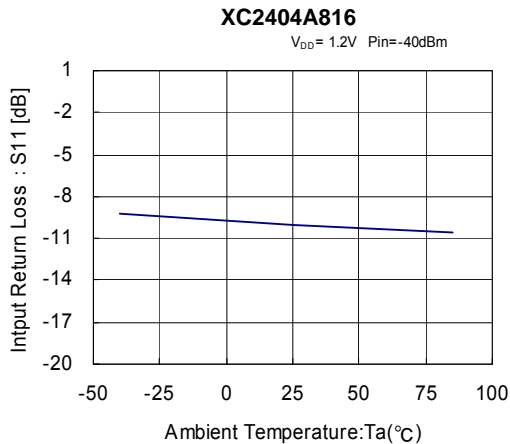

(12) Output Return Loss vs. Ambient Temperature

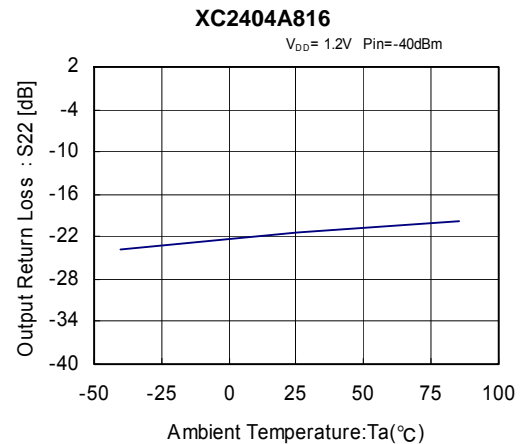

TYPICAL PERFORMANCE CHARACTERISTICS (Continued)

(13) Reverse Isolation vs. Ambient Temperature

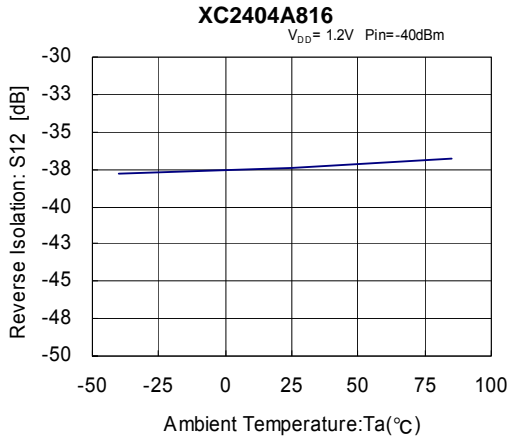

(14) Noise Figure vs. Ambient Temperature

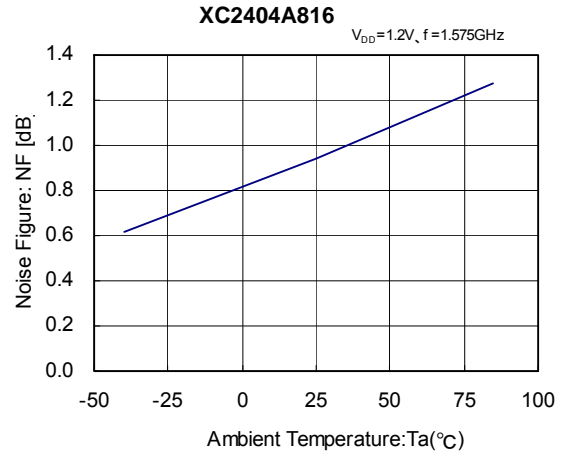

(15) Input 3 Order intercept point vs. Ambient Temperature

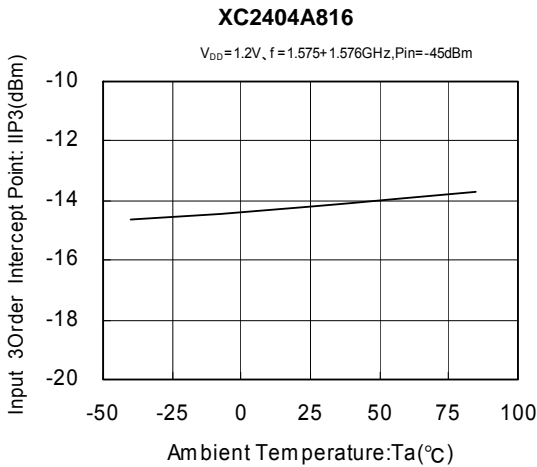

(16) Input Power @ 1dB Gain Compression vs. Ambient Temperature

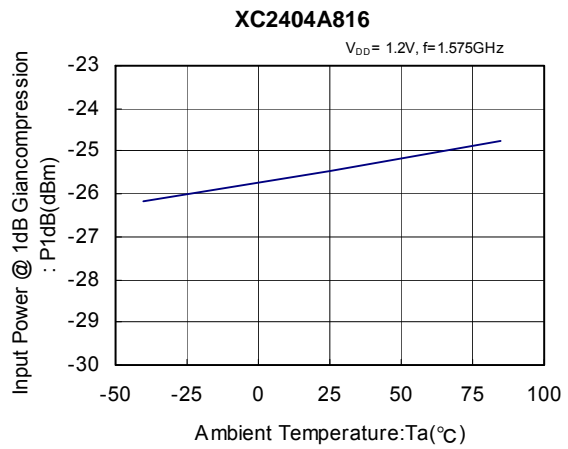

(17) Power Gain vs. Frequency

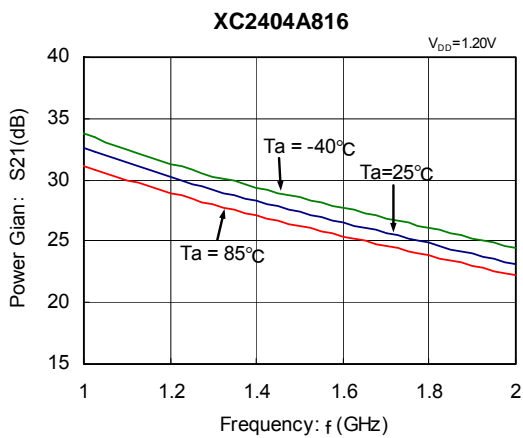

(18) Input Return Loss vs. Frequency

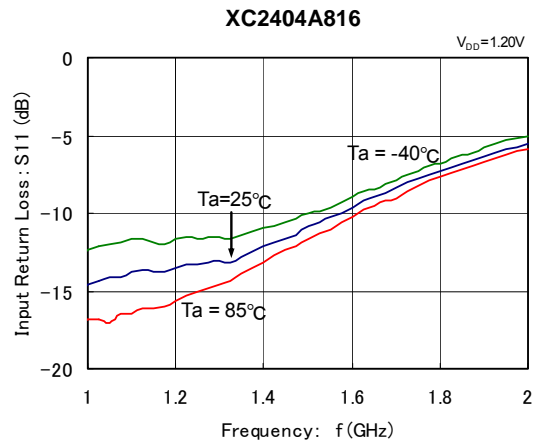

## TYPICAL PERFORMANCE CHARACTERISTICS (Continued)

(19) Output Return Loss vs. Frequency

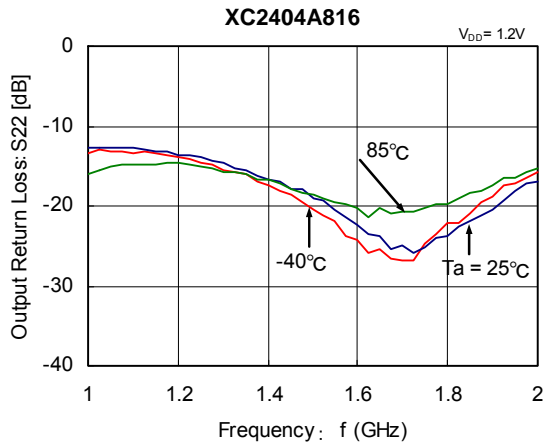

(20) Isolation vs. Frequency

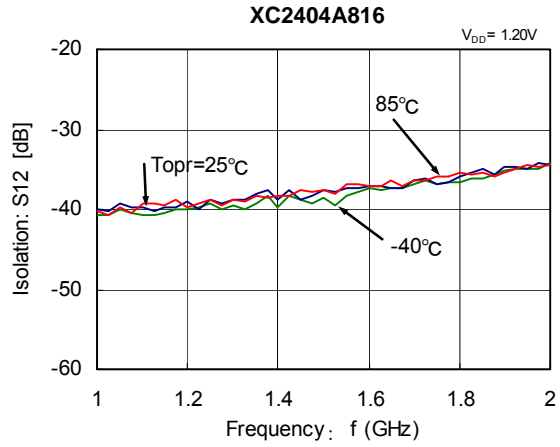

(21) Input Return Loss vs. Frequency (Smith Chart)

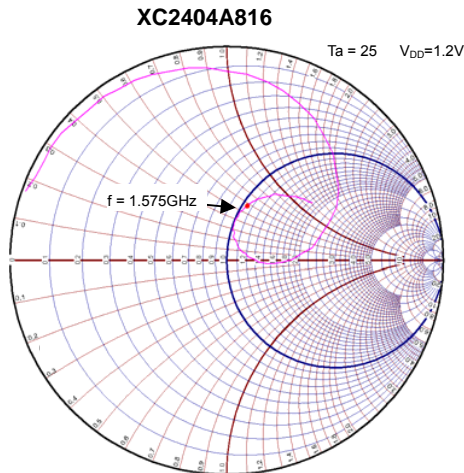

(22) Output Return Loss vs. Frequency (Smith Chart)

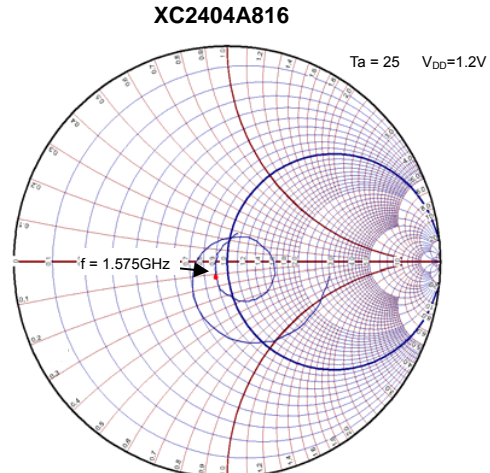

(23) Noise Figure vs. Frequency

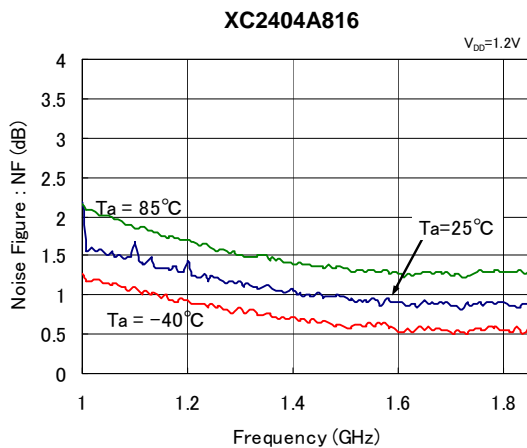

(24) Power Gain vs. Input Power

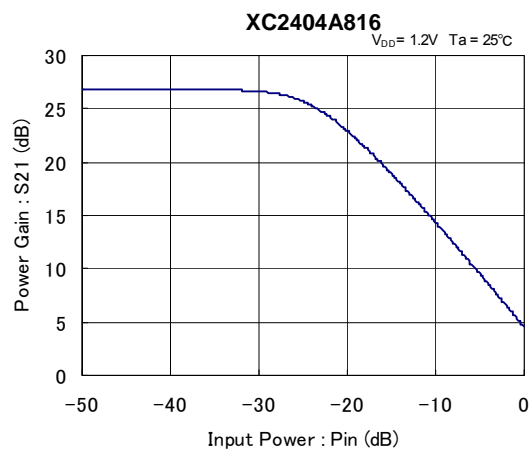

## PACKAGING INFORMATION

USP-8A01

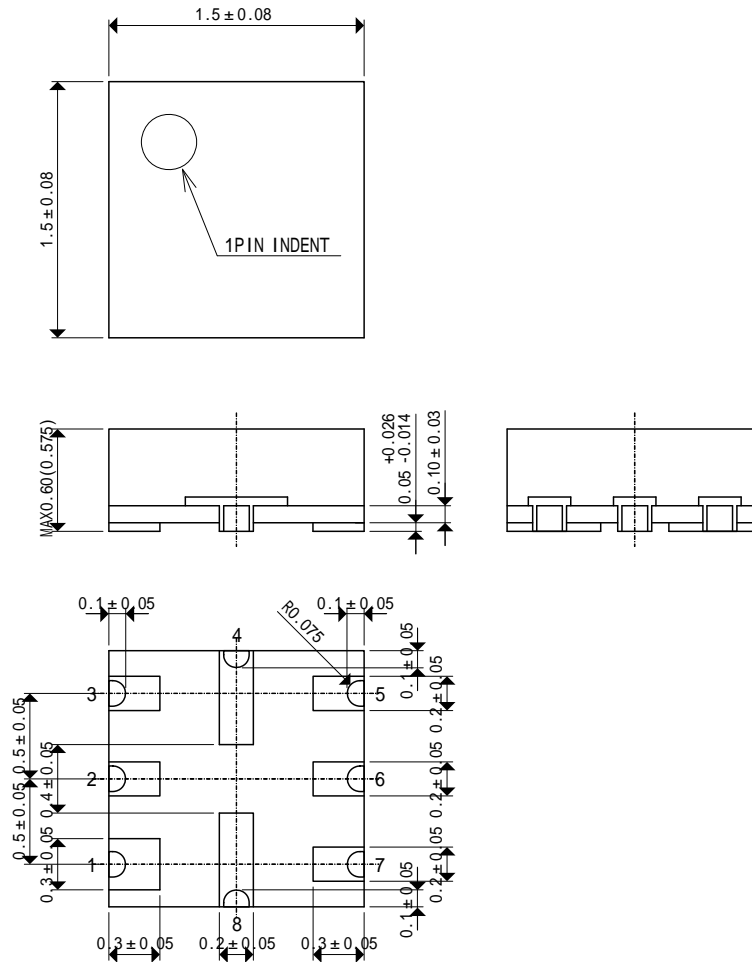

# XC2404A816UR-G

## PACKAGING INFORMATION (Continued)

USP-8A01 Reference Pattern Layout

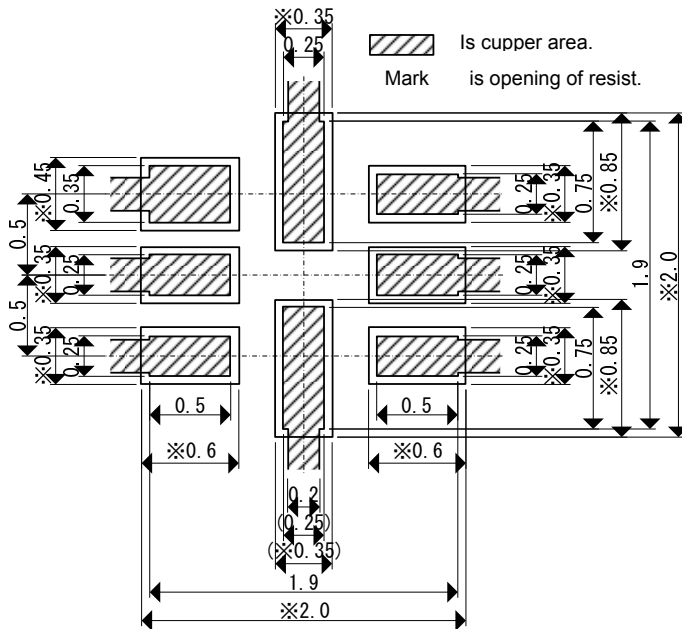

USP-8A01 Reference Metal Mask Design

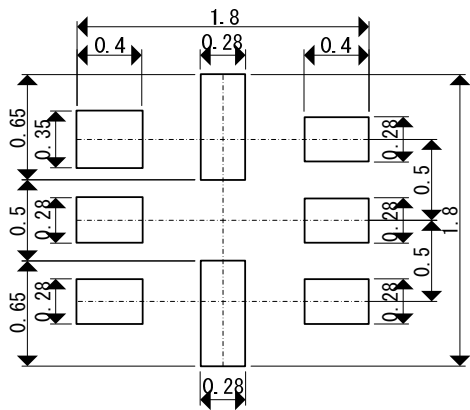

# MARKING RULE

represents product series.

MARK	PRODUCT SERIES
4	XC2404*****-G

represents product.

MARK		PRODUCT SERIES
A	0	XC2404A816**-G

represents production lot number.

01 to 09, 0A to 0Z, 11 to 9Z, A1 to A9, AA to Z9, ZA to ZZ in order.  
(G, I, J, O, Q, W excepted)

\*No character inversion used.

USP-8A01

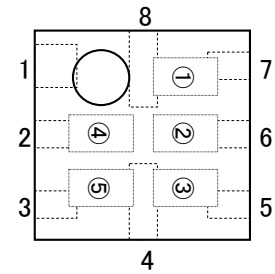

1. The products and product specifications contained herein are subject to change without notice to improve performance characteristics. Consult us, or our representatives before use, to confirm that the information in this datasheet is up to date.
2. We assume no responsibility for any infringement of patents, patent rights, or other rights arising from the use of any information and circuitry in this datasheet.
3. Please ensure suitable shipping controls (including fail-safe designs and aging protection) are in force for equipment employing products listed in this datasheet.
4. The products in this datasheet are not developed, designed, or approved for use with such equipment whose failure of malfunction can be reasonably expected to directly endanger the life of, or cause significant injury to, the user.  
(e.g. Atomic energy; aerospace; transport; combustion and associated safety equipment thereof.)
5. Please use the products listed in this datasheet within the specified ranges.  
Should you wish to use the products under conditions exceeding the specifications, please consult us or our representatives.
6. We assume no responsibility for damage or loss due to abnormal use.
7. All rights reserved. No part of this datasheet may be copied or reproduced without the prior permission of TOREX SEMICONDUCTOR LTD.

**TOREX SEMICONDUCTOR LTD.**