

# 18.0-34.0 GHz GaAs MMIC Receiver

May 2006 - Rev 21-May-06

XR1002

## Features

- ✕ Fundamental High Dynamic Range Receiver
- ✕ Integrated Gain Control
- ✕ +4.0 dBm Input Third Order Intercept (IIP3)
- ✕ 14.0 dB Conversion Gain
- ✕ 3.0 dB Noise Figure
- ✕ 25.0 dB Image Rejection
- ✕ 100% On-Wafer RF, DC and Noise Figure Testing
- ✕ 100% Visual Inspection to MIL-STD-883 Method 2010

## General Description

Mimix Broadband's 18.0-34.0 GHz GaAs MMIC receiver has a 12.0 dB gain control range, a noise figure of 3.0 dB and 25.0 dB image rejection across the band. This device is a three stage LNA followed by a single transistor "Tee" attenuator and an image reject fundamental resistive HEMT mixer. At high signal levels the radio AGC system can be used to reduce the receiver gain improving the IIP3 providing for minimum distortion at modulation schemes as high as 256 QAM (ETSI-see Technical Note 1). The image reject mixer eliminates the need for a bandpass filter after the LNA to remove thermal noise at the image frequency. I and Q mixer outputs are provided and an external 90 degree hybrid is required to select the desired sideband. This MMIC uses Mimix Broadband's 0.15  $\mu\text{m}$  GaAs PHEMT device model technology, and is based upon electron beam lithography to ensure high repeatability and uniformity. The chip has surface passivation to protect and provide a rugged part with backside via holes and gold metallization to allow either a conductive epoxy or eutectic solder die attach process. This device is well suited for Millimeter-wave Point-to-Point Radio, LMDS, SATCOM and VSAT applications.

## Chip Device Layout

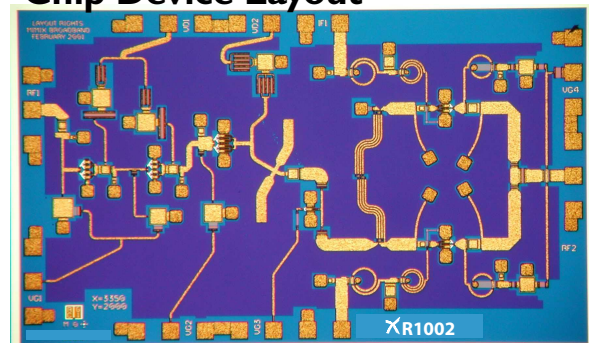

## Absolute Maximum Ratings

|                            |                               |
|----------------------------|-------------------------------|
| Supply Voltage (Vd)        | +6.0 VDC                      |
| Supply Current (Id)        | 300 mA                        |
| Gate Bias Voltage (Vg)     | +0.3 VDC                      |
| Input Power (RF Pin)       | 0.0 dBm                       |
| Storage Temperature (Tstg) | -65 to +165 °C                |
| Operating Temperature (Ta) | -55 to MTF Table <sup>3</sup> |
| Channel Temperature (Tch)  | MTF Table <sup>3</sup>        |

- (1) Measured using constant current, 10dB attenuation and -20dBm total input power.
- (2) At minimum attenuation.
- (3) Channel temperature affects a device's MTF. It is recommended to keep channel temperature as low as possible for maximum life.

## Electrical Characteristics (Ambient Temperature T = 25° C)

| Parameter   | Units | Min.  | Typ.  | Max.  |
|---|-------|-------|-------|-------|
| Frequency Range (RF) Upper Side Band                  | GHz   | 18.0  | -     | 34.0  |
| Frequency Range (RF) Lower Side Band                  | GHz   | 18.0  | -     | 34.0  |
| Frequency Range (LO)                                  | GHz   | 14.0  | -     | 38.0  |
| Frequency Range (IF)                                  | GHz   | DC    | -     | 4.0   |
| Input Return Loss RF (S11)                            | dB    | -     | 10.0  | -     |
| Small Signal Conversion Gain RF/IF (S21) <sup>2</sup> | dB    | 11.0  | 14.0  | -     |
| Attenuation   | dB    | 0.0   | -     | 12.0  |
| LO Input Drive (P <sub>LO</sub> )                     | dBm   | +12.0 | +15.0 | +18.0 |
| Image Rejection                                       | dBc   | 15.0  | 25.0  | -     |
| Noise Figure (NF)                                     | dB    | -     | 3.0   | 3.7   |
| Isolation LO/RF                                       | dB    | -     | 40.0  | -     |
| Input Third Order Intercept (IIP3) <sup>1</sup>       | dBm   | -     | +4.0  | -     |
| Drain Bias Voltage (Vd1,2)                            | VDC   | -     | +4.5  | +5.5  |
| Gate Bias Voltage (Vg1,2) (Vg4=-0.8V)                 | VDC   | -1.0  | -0.5  | 0.0   |
| Control Bias Voltage (Vg3)                            | VDC   | -1.5  | -1.2  | 0.0   |
| Supply Current (Id) (Vd=4.5V, Vg=-0.5V Typical)       | mA    | -     | 135   | 270   |

# 18.0-34.0 GHz GaAs MMIC Receiver

May 2006 - Rev 21-May-06

## Receiver Measurements

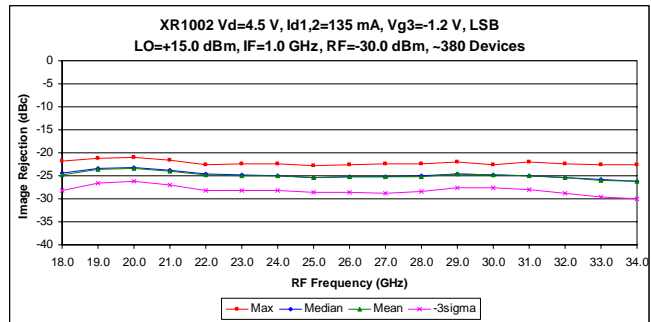
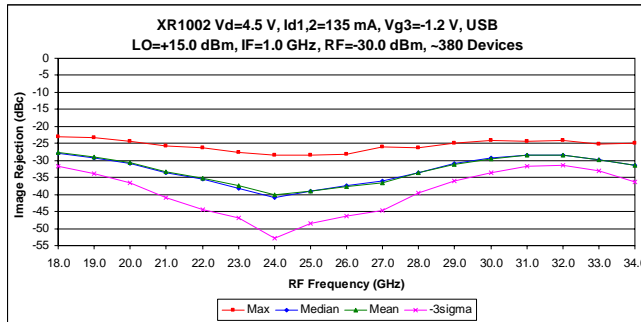
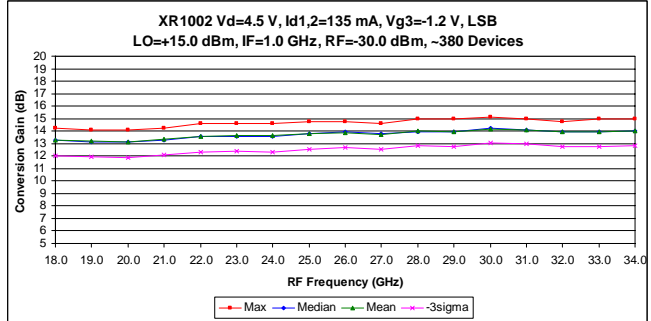
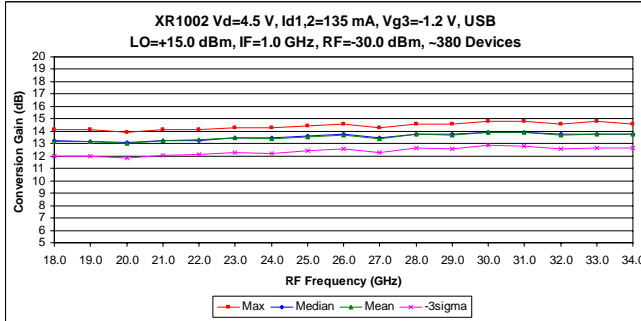

# 18.0-34.0 GHz GaAs MMIC Receiver



XR1002

May 2006 - Rev 21-May-06

## Receiver Measurements (cont.)

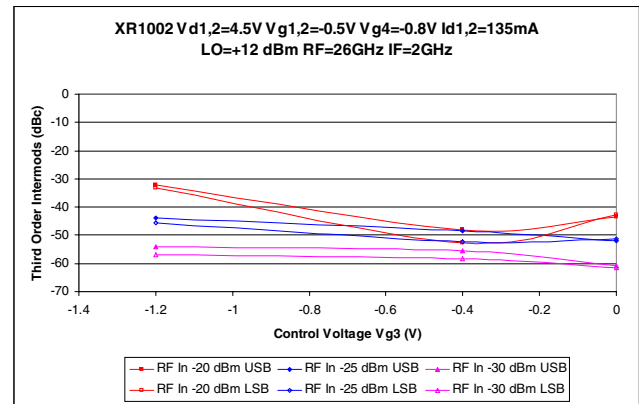
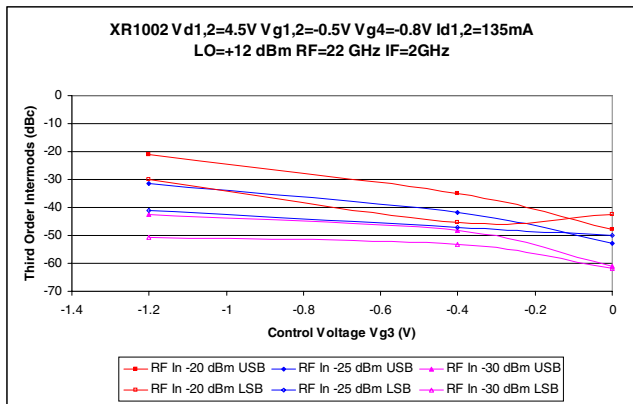
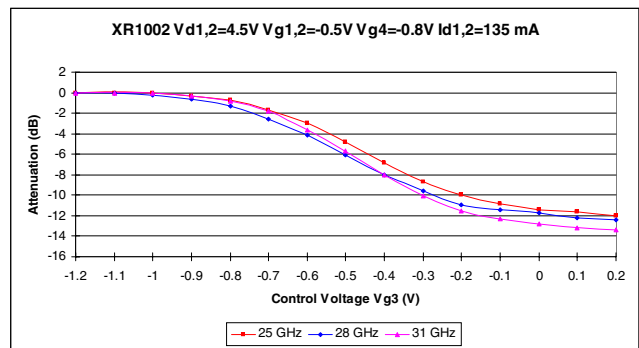
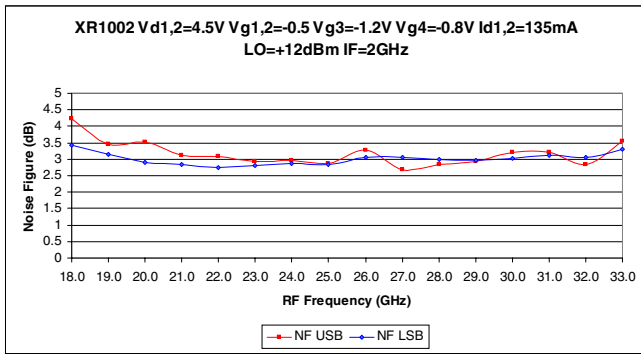
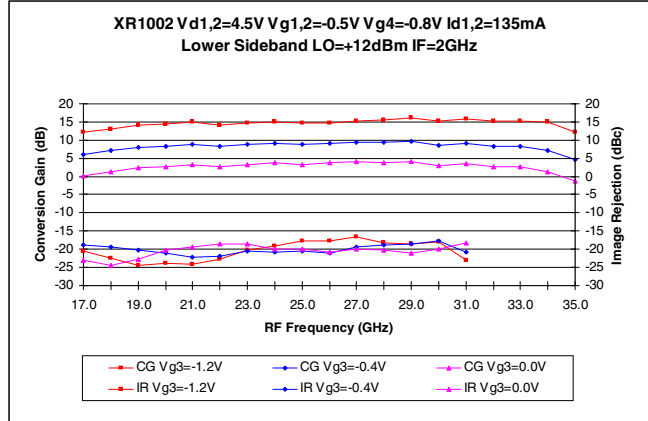
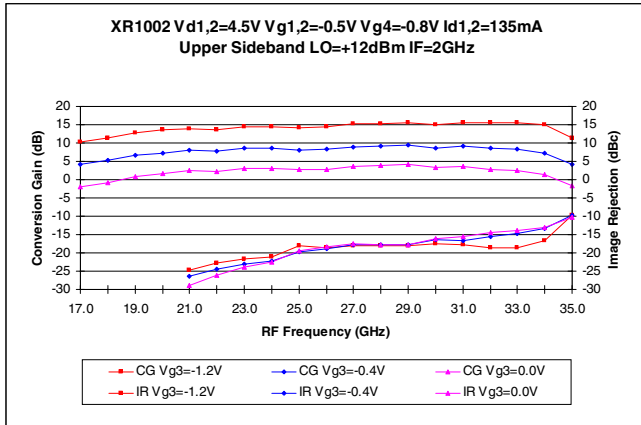

# 18.0-34.0 GHz GaAs MMIC Receiver

## Receiver Measurements (cont.)

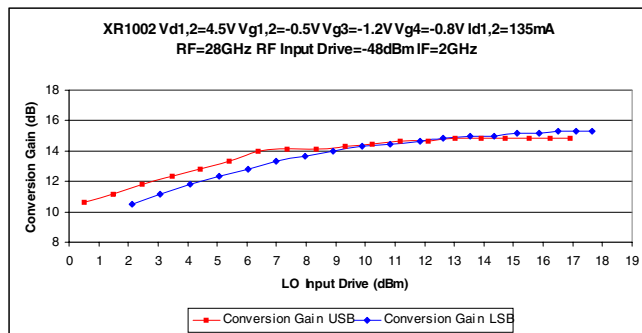
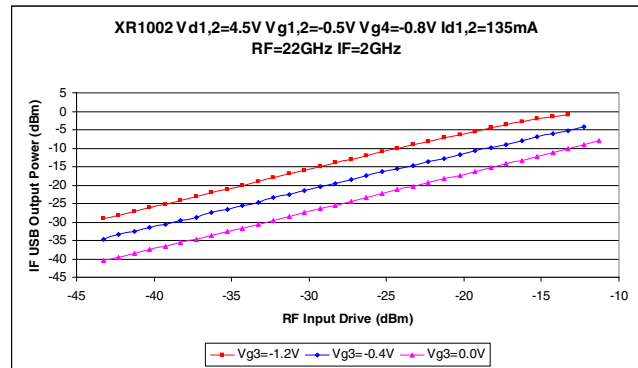
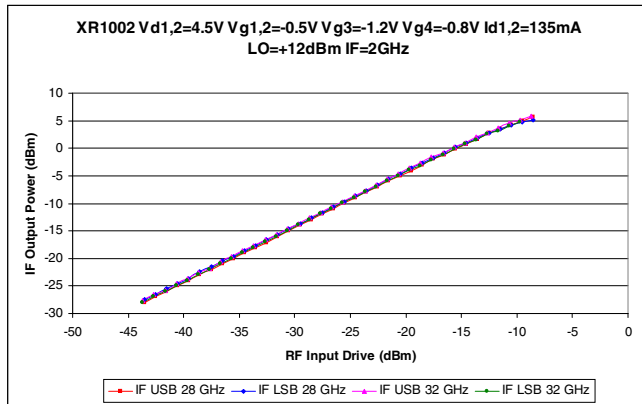

# 18.0-34.0 GHz GaAs MMIC Receiver

May 2006 - Rev 21-May-06

X R1002

## Mechanical Drawing

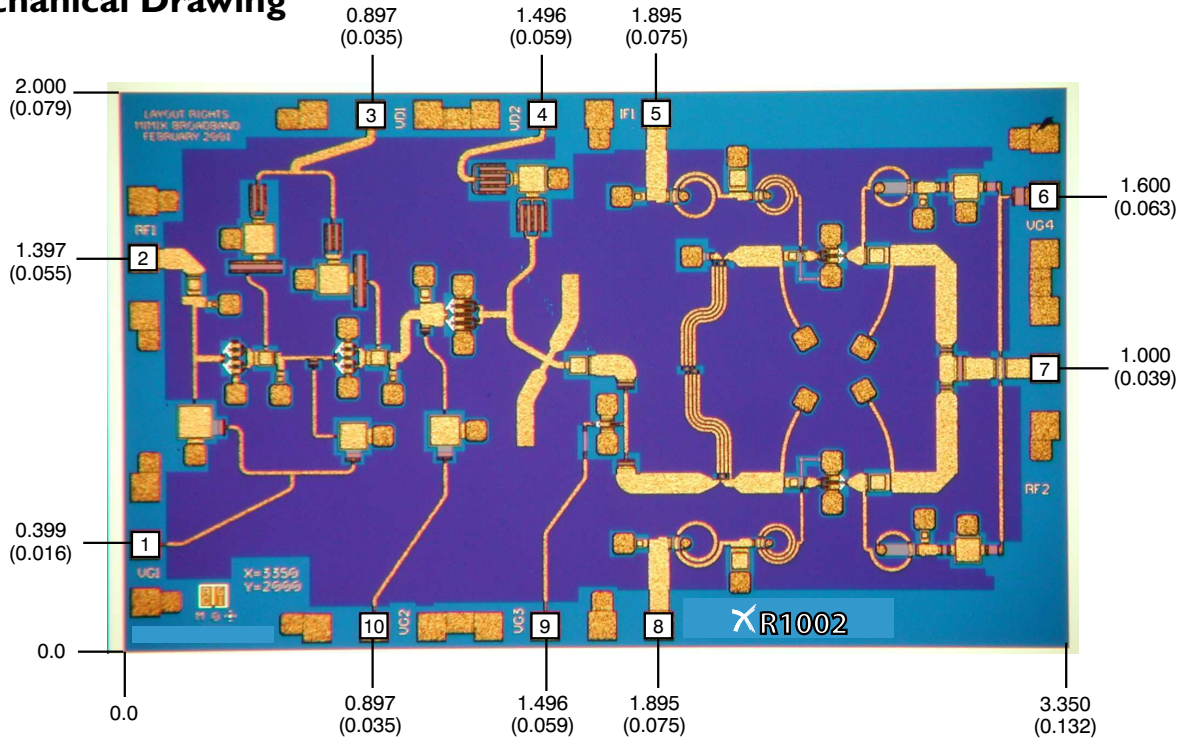

(Note: Engineering designator is 30KR\_03A)

Units: millimeters (inches) Bond pad dimensions are shown to center of bond pad.  
 Thickness: 0.110 +/- 0.010 (0.0043 +/- 0.0004), Backside is ground, Bond Pad/Backside Metallization: Gold  
 All Bond Pads are 0.100 x 0.100 (0.004 x 0.004).  
 Bond pad centers are approximately 0.109 (0.004) from the edge of the chip.  
 Dicing tolerance: +/- 0.005 (+/- 0.0002). Approximate weight: 4.152 mg.

Bond Pad #1 (Vg1)  
 Bond Pad #2 (RF)

Bond Pad #3 (Vd1)  
 Bond Pad #4 (Vd2)

Bond Pad #5 (IF1)  
 Bond Pad #6 (Vg4)

Bond Pad #7 (LO)  
 Bond Pad #8 (IF2)

Bond Pad #9 (Vg3)  
 Bond Pad #10 (Vg2)

## Bias Arrangement

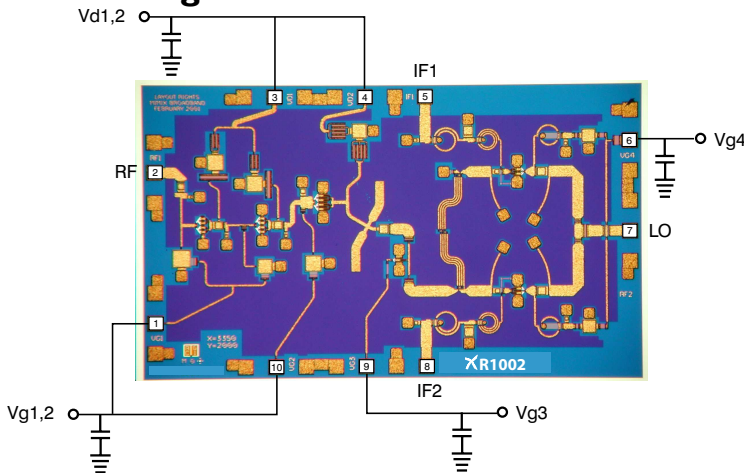

Bypass Capacitors - See App Note [2]

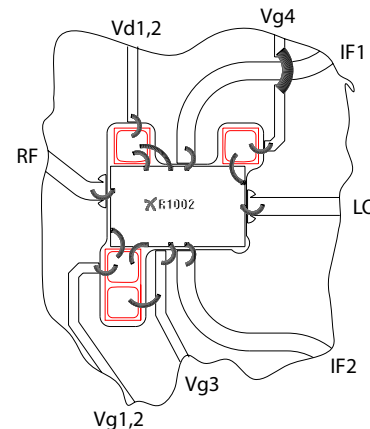

Mimix Broadband, Inc., 10795 Rockley Rd., Houston, Texas 77099  
 Tel: 281.988.4600 Fax: 281.988.4615 mimixbroadband.com

Page 5 of 10

Characteristic Data and Specifications are subject to change without notice. ©2006 Mimix Broadband, Inc.  
 Export of this item may require appropriate export licensing from the U.S. Government. In purchasing these parts, U.S. Domestic customers accept their obligation to be compliant with U.S. Export Laws.

# 18.0-34.0 GHz GaAs MMIC Receiver

May 2006 - Rev 21-May-06

**App Note [1] Biasing** - As shown in the bonding diagram, this device is operated with both stages in parallel, and can be biased for low noise performance or high power performance. Low noise bias is nominally  $V_d=4.5V$ ,  $I_d=135mA$  and is the recommended bias condition. More controlled performance will be obtained by separately biasing  $V_{d1}$  and  $V_{d2}$  each at 4.5V, 65mA. Power bias may be as high as  $V_d=5.5V$ ,  $I_d=270mA$  with all stages in parallel, or most controlled performance will be obtained by separately biasing  $V_{d1}$  and  $V_{d2}$  each at 5.5V, 135mA. Attenuator bias,  $V_{g3}$ , can be adjusted from 0.0 to -1.2V with 0.0V providing maximum attenuation and -1.2V providing minimum attenuation. Image reject mixer bias,  $V_{g4}$ , should nominally be -0.8V to minimize sensitivity of mixer performance to LO level. It is also recommended to use active biasing to keep the currents constant as the RF power and temperature vary; this gives the most reproducible results. Depending on the supply voltage available and the power dissipation constraints, the bias circuit may be a single transistor or a low power operational amplifier, with a low value resistor in series with the drain supply used to sense the current. The gate of the pHEMT is controlled to maintain correct drain current and thus drain voltage. The typical gate voltage needed to do this is -0.5V. Typically the gate is protected with Silicon diodes to limit the applied voltage. Also, make sure to sequence the applied voltage to ensure negative gate bias is available before applying the positive drain supply.

## App Note [2] Bias Arrangement -

For Parallel Stage Bias -- The same as Individual Stage Bias but all the drain or gate pad DC bypass capacitors (~100-200 pF) can be combined. Additional DC bypass capacitance (~0.01 uF) is also recommended to all DC or combination (if gate or drains are tied together) of DC bias pads.

For Individual Stage Bias -- Each DC pad ( $V_{d1,2}$  and  $V_{g1,2,3,4}$ ) needs to have DC bypass capacitance (~100-200 pF) as close to the device as possible. Additional DC bypass capacitance (~0.01 uF) is also recommended.

## MTTF Tables

These numbers were calculated based on accelerated life test information and thermal model analysis received from the fabricating foundry.

| Backplate Temperature | Channel Temperature | Rth       | MTTF Hours | FITs     |
|-----------------------|---------------------|-----------|------------|----------|
| 55 deg Celsius        | 81 deg Celsius      | -         | 6.77E+11   | 1.48E-03 |
| 75 deg Celsius        | 101 deg Celsius     | 65.0° C/W | 4.09E+10   | 2.44E-02 |
| 95 deg Celsius        | 121 deg Celsius     | -         | 3.29E+09   | 3.04E-01 |

**Bias Conditions:**  $V_d=3.0V$ ,  $I_d=135 mA$

| Backplate Temperature | Channel Temperature | Rth       | MTTF Hours | FITs     |
|-----------------------|---------------------|-----------|------------|----------|
| 55 deg Celsius        | 142 deg Celsius     | -         | 4.11E+08   | 2.43E+00 |
| 75 deg Celsius        | 162 deg Celsius     | 58.9° C/W | 5.36E+07   | 1.87E+01 |
| 95 deg Celsius        | 182 deg Celsius     | -         | 8.35E+06   | 1.20E+02 |

**Bias Conditions:**  $V_d=5.5V$ ,  $I_d=270 mA$

# 18.0-34.0 GHz GaAs MMIC Receiver

## App Note [3] USB/LSB Selection -

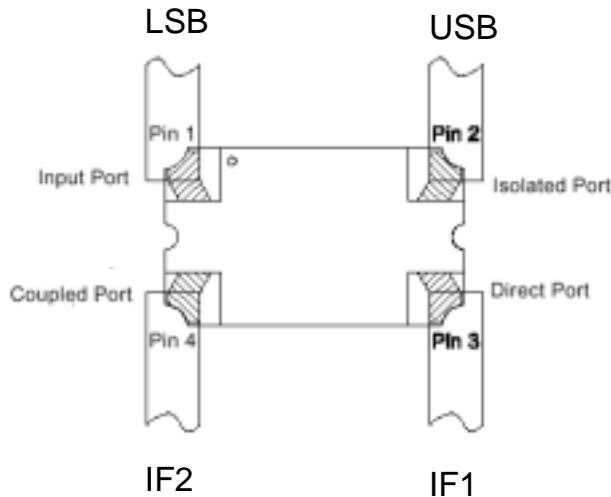

### For Upper Side Band operation (USB):

With IF1 and IF2 connected to the direct port ( $0^\circ$ ) and coupled port ( $90^\circ$ ) respectively as shown in the diagram, the USB signal will reside on the isolated port. The input port must be loaded with 50 ohms.

### For Lower Side Band operation (LSB):

With IF1 and IF2 connected to the direct port ( $0^\circ$ ) and coupled port ( $90^\circ$ ) respectively as shown in the diagram, the LSB signal will reside on the input port. The isolated port must be loaded with 50 ohms.

An alternate method of Selection of USB or LSB:

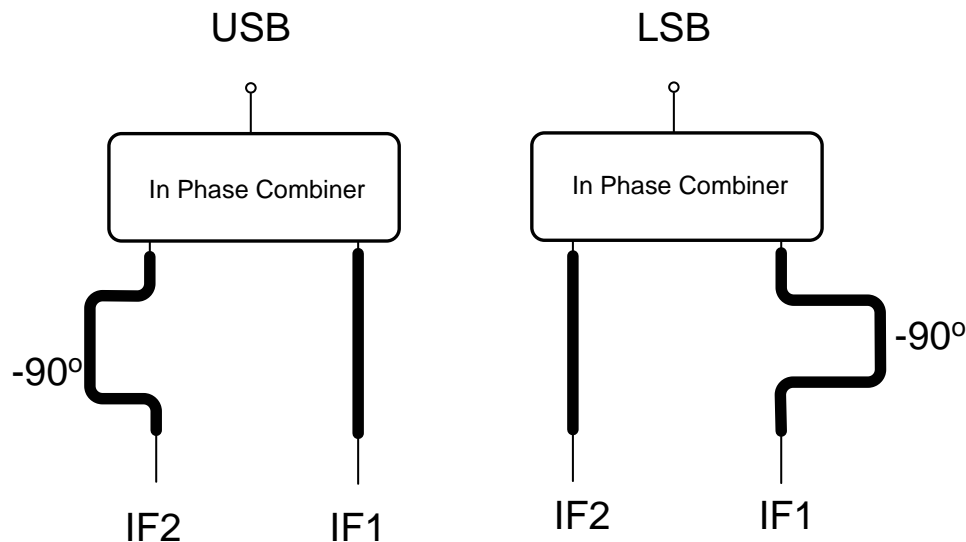

# 18.0-34.0 GHz GaAs MMIC Receiver

## Device Schematic

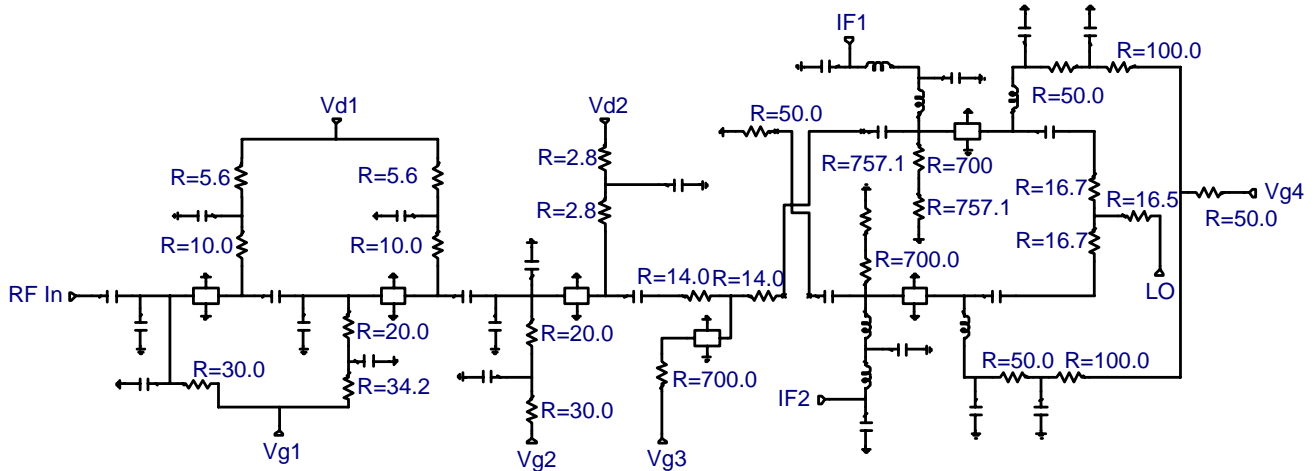

## Typical Application

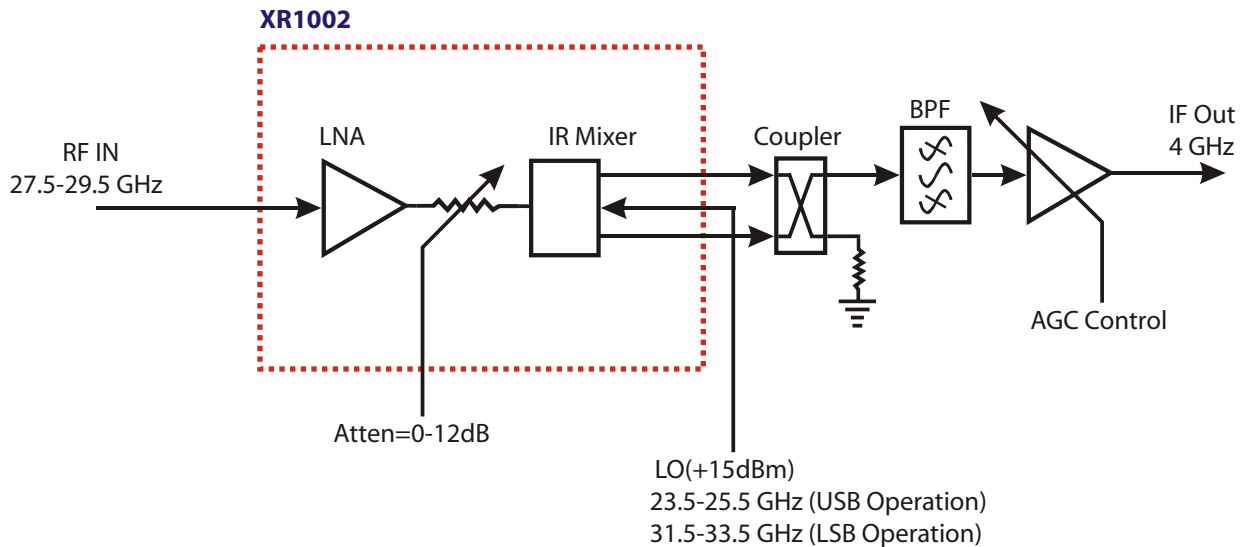

### Mimix Broadband MMIC-based 18.0-34.0 GHz Receiver Block Diagram

(Changing LO and IF frequencies as required allows design to operate as high as 34 GHz)

**Also See:** Multiplier selection guide at [www.mimixbroadband.com](http://www.mimixbroadband.com) for multipliers that can be used to drive the XR1002.



# 18.0-34.0 GHz GaAs MMIC Receiver

**Tech Note [1] Assumptions on Modulation** - The effect of intermodulation on the performance of a QAM radio is determined by many factors. By making some reasonable assumptions, it can be deduced that the XR1002 will conform with ETSI-specified high receive power requirements when operating in radios with modulations of up to 256QAM and higher.

For a Gray-coded QAM signals passing through a AWGN channel, an optimal receiver will require the C/N ratios shown in Figure 1.

| QAM level | C/N for 1E-3(dB) | Assumed IM3 for 1E-3 (dBm) | IIP3 for 1E-3 (dBm) |
|-----------|------------------|----------------------------|---------------------|
| 16        | 16.6             | -39.6                      | -14.7               |
| 64        | 22.6             | -45.6                      | -11.7               |
| 128       | 25.6             | -48.6                      | -10.2               |
| 256       | 28.6             | -51.6                      | -8.7                |

Figure 1: C/N and IM3/IIP3 values for QAM (Pin=-20dBm and BER=1E-3)

To estimate the IM3 required to produce a BER of 1E-3 involves many approximations, and assumptions on the radio and modem characteristics. Following is an example which is based on the assumptions listed. All of the values of 'Assumed IM3 for 1E-3' listed in Figure 1 are derived using this method.

For a total input power at the receiver of -20dBm, this equates to a per-tone level of -23dBm, for a two-tone input. From Figure 1, an optimal 64 QAM receiver will require a 22.6dB C/N for a 1E-3 BER [F]. Therefore, the assumed in-band IM3 for 1E-3 performance is  $-23 - 22.6 = -45.6$ dBm. From this, the required IIP3 for 64 QAM is  $-23 + 22.6/2 = -11.7$ dBm.

#### Assumptions:

- [A] The C/N figure for 1E-3 BER assumes a matched receiver with no implementation loss, and no degradation due to phase noise.
- [B] All third order intermodulation falls in the pass-band. In reality, some of the intermodulation will fall in the adjacent channels, and can be removed by filtering. This assumption makes this analysis conservative.
- [C] The amplitude distribution of the distortion products can be approximated to that of thermal noise. There is a relatively high degree of uncertainty in this assumption as the peak to average ratio for the signal depends on alpha, and the statistics of the third order signal distortion are unknown.
- [D] The addition of interference at a level of 6dB below the AWGN due to the channel, increases the effective noise by 1dB. This is true if the interference has identical Gaussian statistics to the channel's AWGN.
- [E] The receiver input level range is set at an upper limit of -20dBm for 1E-3 BER performance [1][2][3]. This input level is referenced before the branching [1][2][3], which in reality may bring the upper limit down below -21 dBm. The exact number will depend on the particular system, so a worst-case hypothetical situation of no branching loss will be assumed.
- [F] The 1E-3 BER performance can depend greatly on the presence and performance of FEC. The worst case situation of NO FEC has been assumed in these derivations.

#### References:

- [1] ETSI EN 300 198 V1.4.1 (2001-02): "Fixed Radio Systems; Point-to-point equipment; Parameter for radio systems for the transmission of digital signals operating at 23 GHz"
- [2] ETSI EN 300 431 V1.3.1 (2001-02): "Fixed Radio Systems; Point-to-point equipment; Parameters for radio system for the transmission of digital signals operating in the frequency range 24,5 GHz to 29,50 GHz"
- [3] ETSI EN 300 197 V1.5.1 (2001-10): "Fixed Radio Systems; Point-to-point equipment; Parameters for radio system for the transmission of digital signals operating at 32 GHz and 38 GHz"

# 18.0-34.0 GHz GaAs MMIC Receiver

May 2006 - Rev 21-May-06

## Handling and Assembly Information

**CAUTION!** - Mimix Broadband MMIC Products contain gallium arsenide (GaAs) which can be hazardous to the human body and the environment. For safety, observe the following procedures:

- *Do not ingest.*
- *Do not alter the form of this product into a gas, powder, or liquid through burning, crushing, or chemical processing as these by-products are dangerous to the human body if inhaled, ingested, or swallowed.*
- *Observe government laws and company regulations when discarding this product. This product must be discarded in accordance with methods specified by applicable hazardous waste procedures.*

**Life Support Policy** - Mimix Broadband's products are not authorized for use as critical components in life support devices or systems without the express written approval of the President and General Counsel of Mimix Broadband. As used herein: (1) Life support devices or systems are devices or systems which, (a) are intended for surgical implant into the body, or (b) support or sustain life, and whose failure to perform when properly used in accordance with instructions for use provided in the labeling, can be reasonably expected to result in a significant injury to the user. (2) A critical component is any component of a life support device or system whose failure to perform can be reasonably expected to cause the failure of the life support device or system, or to affect its safety or effectiveness.

**ESD** - Gallium Arsenide (GaAs) devices are susceptible to electrostatic and mechanical damage. Die are supplied in antistatic containers, which should be opened in cleanroom conditions at an appropriately grounded anti-static workstation. Devices need careful handling using correctly designed collets, vacuum pickups or, with care, sharp tweezers.

**Die Attachment** - GaAs Products from Mimix Broadband are 0.100 mm (0.004") thick and have vias through to the backside to enable grounding to the circuit. Microstrip substrates should be brought as close to the die as possible. The mounting surface should be clean and flat. If using conductive epoxy, recommended epoxies are Ablestick 84-1LMI or 84-1LMIT cured in a nitrogen atmosphere per manufacturer's cure schedule. Apply epoxy sparingly to avoid getting any on to the top surface of the die. An epoxy fillet should be visible around the total die periphery. If eutectic mounting is preferred, then a fluxless gold-tin (AuSn) preform, approximately 0.001<sup>2</sup> thick, placed between the die and the attachment surface should be used. A die bonder that utilizes a heated collet and provides scrubbing action to ensure total wetting to prevent void formation in a nitrogen atmosphere is recommended. The gold-tin eutectic (80% Au 20% Sn) has a melting point of approximately 280°C (Note: Gold Germanium should be avoided). The work station temperature should be 310°C ± 10°C. Exposure to these extreme temperatures should be kept to minimum. The collet should be heated, and the die pre-heated to avoid excessive thermal shock. Avoidance of air bridges and force impact are critical during placement.

**Wire Bonding** - Windows in the surface passivation above the bond pads are provided to allow wire bonding to the die's gold bond pads. The recommended wire bonding procedure uses 0.076 mm x 0.013 mm (0.003" x 0.0005") 99.99% pure gold ribbon with 0.5-2% elongation to minimize RF port bond inductance. Gold 0.025 mm (0.001") diameter wedge or ball bonds are acceptable for DC Bias connections. Aluminum wire should be avoided. Thermo-compression bonding is recommended though thermosonic bonding may be used providing the ultrasonic content of the bond is minimized. Bond force, time and ultrasonics are all critical parameters. Bonds should be made from the bond pads on the die to the package or substrate. All bonds should be as short as possible.