

1. Scope :

This specification applies for the CN22 series of thick film chip resistor arrays made by TA-I.

2. Construction , Dimensions , Schematic :

2.1 Construction :

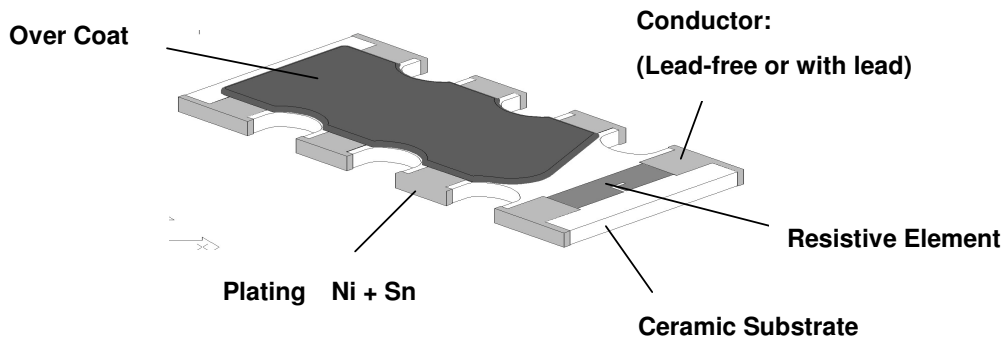

2.1.1 Chip Resistor Arrays :

CN22

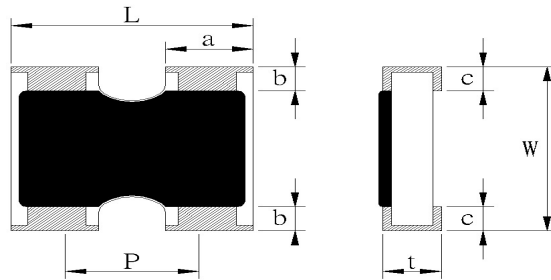

2.2 Dimension :

UNIT:mm

Type	L	W	t	P	a	b	c
CN22	1.0 ± 0.1	1.0 ± 0.1	0.35 ± 0.1	0.65 ± 0.1	0.33 ± 0.1	0.15 ± 0.1	0.25 ± 0.1

2.3 Schematic :

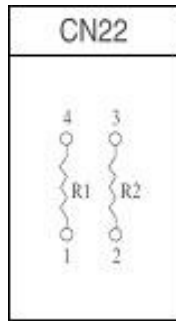

3. Type Designation:

3.1 Chip Resistor Arrays

<u>CN</u>	<u>22</u>	<u>J</u>	<u>TN</u>	<u>103</u>
Product Code	size	Tolerance	Packaging	Nominal Resistance
CN : Chip Resistor Array	Power Rating			
	22-0402*2	J-±5% G-±2% F-±1%	T- Paper Tape N : Lead-free	3 digits e.g.,: (E-24) 103 = 10KΩ 5R6 = 5.6Ω 4 digits e.g., : (E-96) 1540 = 154Ω 43R2 = 43.2

Note :

TN : Lead-Free products packaged by paper tape

4. Ratings & Characteristics :

Type	Power Rating at 70°C	Rating Voltage	Max. Working Voltage	Max. Over Load Voltage	Operating Temp. (°C)	Resistance Tolerance (%)	Resistance Range (Ω)	Temp Co-efficient PPM/°C
CN22	1/16W	Refer 4.2	25V	50V	-55 ∩ +125°C	±5% ±2% ±1%	10Ω~1MΩ	±250

4.1 Derating Curve :

For resistors operated at ambient temperature over 70°C , power rating shall be derated in accordance with figure 1.

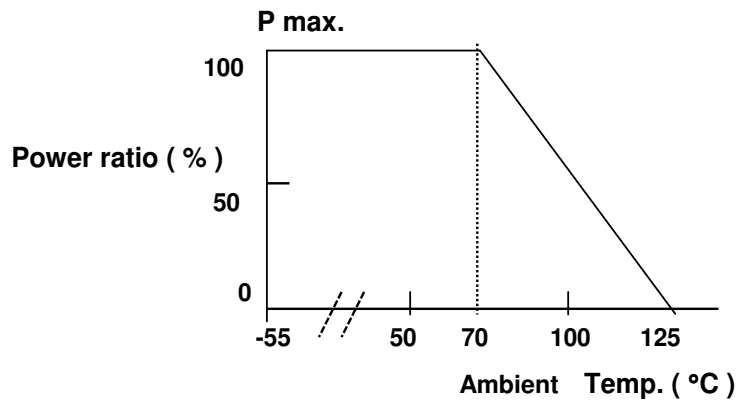

Figure 1

4.2 Rated Voltage:

The rated voltage is calculated by the following formula:

$$E = \sqrt{P * R}$$

E =Rated Voltage(V)
 P =Rated Power(W)
 R =Resistance Value(Ω)

E.G. : What is CN22JTN102 the rated voltage ?

CN22JTN102 P:1/16W ; R:102 = 1KΩ = 1000Ω

$$E = \sqrt{0.0625(W) * 1000(\Omega)} = 7.9 (V)$$

5. Reliability Tests:(As specified in JIS C 5202)

Test Items	Reference standard	Condition of Test	Test Limits
Temperature Coefficient of Resistance	JIS-C5202-5.2	-55 ~ +125 °C	Refer 4.0
Short Time Overload	JIS-C5202-5.5	2.5 X rated voltage for 5 sec	$\pm(2.0\%+0.1\Omega)$ 0 Ω : 50 m Ω or less
Intermittent Overload	JIS-C5202-5.8	2.5X rated voltage or Max Overloading Voltage , 1 sec "ON" 25 sec "OFF" , 10000 cycles	$\pm(5.0\%+0.1\Omega)$ 0 Ω : 50m Ω or less
Load Life	JIS-C5202-7.10	1000 hours at rated voltage , 70°C , 1.5hours "ON" , 0.5hour "OFF"	1%: $\pm(1.0\%+0.05\Omega)$ 5%: $\pm(3.0\%+0.1\Omega)$ 0 Ω :100 m Ω or less
Load Life with Humidity	JIS-C5202-7.9	1000 hours at rated voltage , 40 \pm 2°C , 90~95% RH 1.5hours "ON" , 0.5hour "OFF"	1%: $\pm(1.0\%+0.05\Omega)$ 5%: $\pm(3.0\%+0.1\Omega)$ 0 Ω :100 m Ω or less
Rapid Change of Temperature	JIS-C5202-7.4	-55°C (30 min.) / +155 °C (30 min.) 5 cycles	1%: $\pm(0.5\%+0.05\Omega)$ 5%: $\pm(1.0\%+0.05\Omega)$ 0 Ω :50 m Ω or less
Solderability	JIS-C5202-6.11	245 \pm 5°C solder, 2 \pm 0.5 sec dwell. Solder : Sn96.5 / Ag3.0 / Cu0.5	At least 95% of surface area of electrode shall be covered with new solder.
Core body	JIS C-5202-6.1.4	Pressure 1.0 kgf a R0.5 pressure rod for 10 sec	Without mechanical damage such as breaks. Electrical characteristics shall be satisfied
Dielectric Withstanding Voltage (Voltage Proof)	JIS-C5202-5.7	Applying voltage 100V for 1 minute.	No abnormalities such as flashover, burning dielectric breakdown shall appear.
Resistance to Solder Heat	JIS-C5202-6.10	270 \pm 5°C solder , 10 \pm 1 sec dwell .	0.5%,1%: $\pm(1.0\%+0.05\Omega)$ 2%,5%: $\pm(2.0\%+0.1\Omega)$ 0 Ω : 50m Ω or less

TA-I	Thick Film Chip Resistor Arrays Thick Film Chip Resistor Networks (Lead-Free for CN22 Series)	No	TCN-220S002E
		page	5/10

Whisker	SONY SS-00254-8	<p>Component , Lead-Free Soldering part 8 : Solder Heat Resistance Test for SMD. Lead-Free Soldering "</p> <p>Temp. Cycles : -55°C (30 min.) / +155°C (30 min.) Testing duration : 500±4 hours</p> <p>Temp. Humidity Chambers: Temperature : 85°C Humidity : 85% RH Testing duration : 500±4 hours .</p>	Whisker formation : 50 um or less .
Resistance to Solder Heat	SONY SS-00254-5	<p>Component , Lead-Free Soldering part 5 : Solder Heat Resistance Test for SMD. Lead-Free Soldering "</p> <p>Flow Solder : Pre – heat : 100 to 105 °C 30±5 sec Temperature : 260±3°C 10 +1/ -0 sec The entire sample shall be dipped in solder. The specimen shall be stored at standard atmospheric conditions for 1 hour .</p> <p>Iron Solder : Bit temperature : 350 ±10°C Application time of soldering iron : 3 +1/- 0sec Apply the soldering iron to the electrode . The specimen shall be stored at standard atmospheric conditions for 1 hour , after which the measurements shall be made</p>	Electrical characteristics shall be Satisfied . Without distinct deformation in appearance

Note* : RCWV : Rated continuous working voltage .

6. Marking : No Marking for CN22

7. Taping & Reel :

7.1 Taping Dimensions

7.1.1 2 mm pitch paper

UNIT: mm

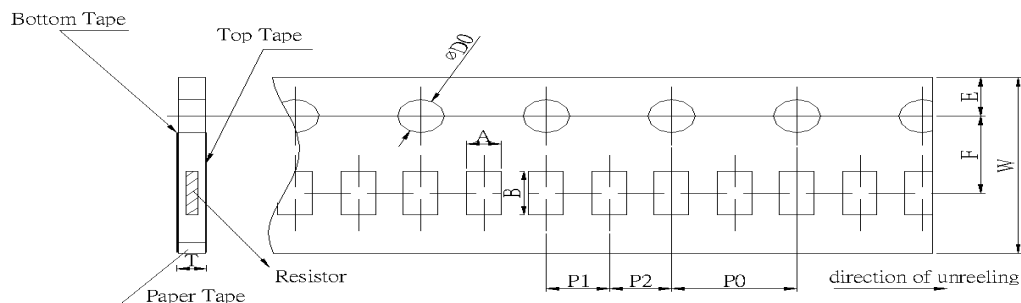

Type	A	B	W	F	E	P1	P2	P0	φ D0	T0
CN22	1.2±0.15	1.2±0.1	8.0±0.2	3.5±0.05	1.75±0.1	2.0±0.1	2.0±0.05	4.0±0.1	1.5 +0.1 -0	0.45±0.1

Package Type	Paper Tape	
	2 mm pitch	
	178mm/R	250mm/R
CN22	10000	20000

7.2 Reel Specifications

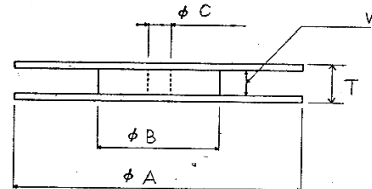
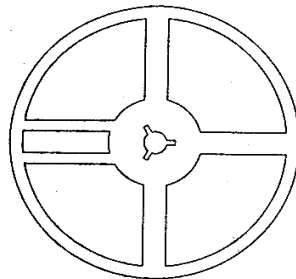

UNIT: mm

Type	φ A	φ B	φ C	W	T
CN22	178.0 ± 2.0	60.0 ± 1.0	13.0 ± 1.0	9.0 ± 1.0	11.5 ± 1.0

7.3 Peel off Strength:

Peel –off force of paper and blister tape is in accordance with “JIS-C5202” that is , 0.1 to 0.7 N at a peel-off speed of 300 mm / minute.

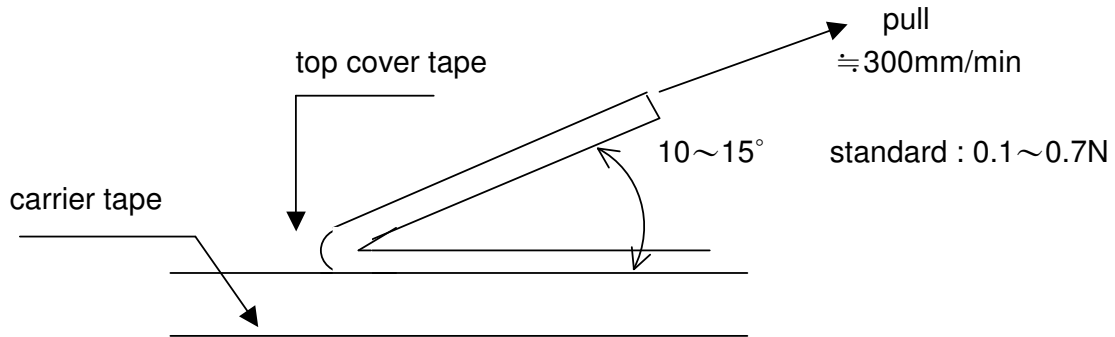

8. Label

8.1 Manufacture Label :

8.1.1 Chip Resistor Array

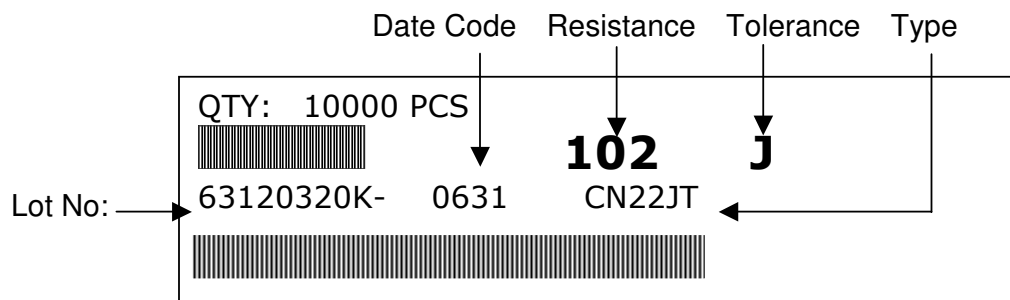

8.2. Customer Label (By customer request):

8.2.1 Chip Resistor Array

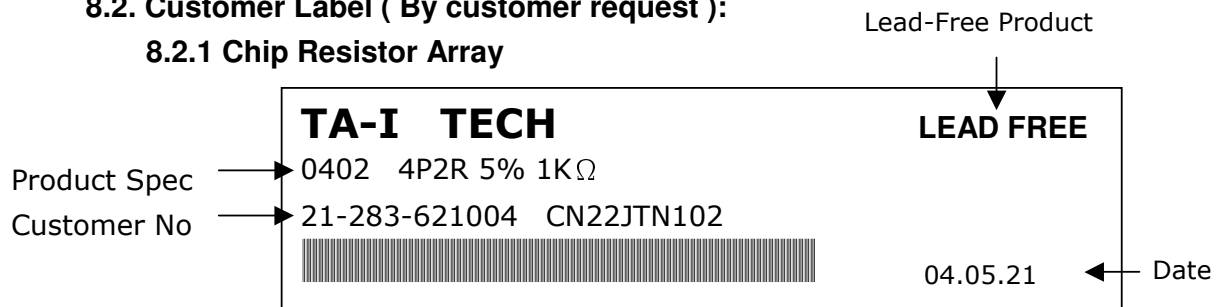

9. Recommended land patterns

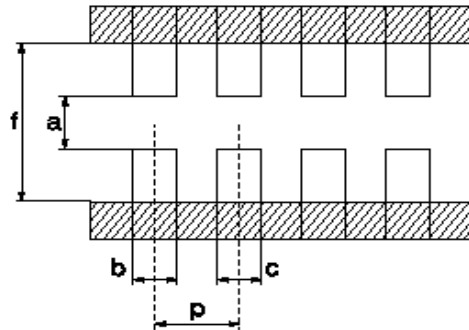

Land pattern		Dimension (mm)				
Type	Size	a	b	c	p	f
CN	22	0.5	0.35~0.4	0.35~0.4	0.65	1.4~1.5

10. Recommend IR – Reflow profile : (solder : Sn96.5 / Ag3 / Cu0.5)

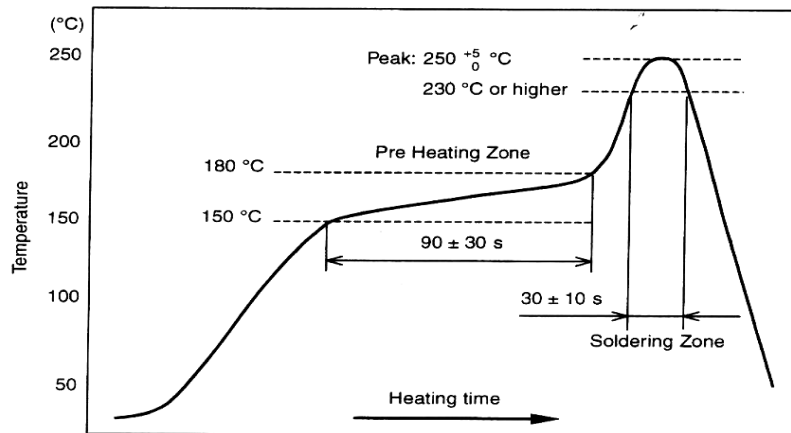

Peak : 250 ⁺⁵/₋₀ °C , 5 sec

Pre – heat Zone : 150 to 180 °C , 90 ± 30 sec

Soldering Zone : 230°C or higher , 30 ± 10 sec

TA-I	Thick Film Chip Resistor Arrays Thick Film Chip Resistor Networks (Lead-Free for CN22 Series)	No	TCN-220S002E
		page	9/10

11. Storage Conditions:

Temperature : 5 to 35 °C

Related Humidity :40 to 75% RH

12. Shelf Life :

2 Years from manufacturing date.

13. ECN :

Engineering Change Notice: The customer will be informed with ECN if there is significant modification on the characteristics and materials described in Approval Sheet.

14. Manufacturing Country & City :

TA-I TECHNOLOGY CO., LTD. (Taiwan– Tao Yuan)

Tel: 886-3-3246169 Fax : 886-3-3246167

Associated companies :

(1) FORTUNE TASK RESISTOR FACTORY (China – Dongguan)

Tel : 86-769-8339-4790~3 Fax : 86-769-8339-4794

(2) TA-I TECHNOLOGY (DONGGUAN) CO., LTD. (China –Dongguan)

Tel : 86-769-8339-4790~3 Fax : 86-769-8339-4794

(3) TA-I TECHNOLOGY (SU ZHOU) CO., LTD. (China – Su Zhou)

Tel :86- 512-63457879 Fax : 86-512-63457869

(4) TAI OHM ELECTRONICS (M) SDN. BHD. (Malaysia – Pulaupinang)

Tel :604- 3900480 Fax : 604-3901481

(5) P.T.TAI ELECTRONICS Indonesia (Indonesia – Jakarta)

Tel :002-62-21-44820254 Fax : 002-62-21-44820256

TA-I TECHNOLOGY CO., LTD

TA-I	Thick Film Chip Resistor Arrays Thick Film Chip Resistor Networks (Lead-Free for CN22 Series)	No	TCN-220S002E
		page	10/10

Revise record

Date	Content	Owner
Nov.25.2005	4. Ratings & Characteristics : Adding Rating Voltage 5. Reliability Tests: Adding to Whisker & Resistance to soldering heat Deleted to Robustness of Termination (Bending Strength) Adding to Core body 7.3 Storage Conditions: Deleted to Storage Conditions 8.2 Customer Label Adding to Customer Label 10. Recommend IR – Reflow profile Adding to Recommend IR – Reflow profile 11. Storage Conditions: Adding to Storage Conditions: 12. Shelf Life Adding to Shelf Life :	Hank Liu
Dec.12.2005	5. Reliability Tests: Intermittent Overload : 3X rate power changed 2.5X rated voltage Whisker : -35±5°C / 125±5°C , Keep 7 min changed -55°C (30 min.)/ +155°C (30 min.)	Hank Liu
Jul.06.2006	2.1 Conductor : Adding to (Lead-free or with lead) 5. Reliability Tests: Temperature Coefficient of Resistance : Refer 5.0 changed Refer4.0 Resistance to Solder Heat : 1%:±(0.5%+0.05 Ω) changed 0.5%,1%:±(1.0%+0.05 Ω) 5%:±(1.0%+0.05 Ω) changed 2%,5%:±(2.0%+0.1 Ω) 8.1 Manufacture label : Series number 3 codes changed to 4 codes 14. Manufacturing Country & City: Adding TA-I TECHNOLOGY (DONGGUAN) CO., LTD	Vincent