



Solid State Devices, Inc.

14830 Valley View Blvd * La Mirada, Ca 90638
 Phone: (562) 404-7855 * Fax: (562) 404-1773
 ssdi@ssdi-power.com * www.ssdi-power.com

SFS884 thru SFS889

**20 AMPS
 15 – 200 VOLTS
 SILICON CONTROLLED
 RECTIFIER**

Designer's Data Sheet

- FEATURES:**
- High Surge Current
 - High On State Current
 - High Frequency up to 400 Hz operation
 - Anode Common to Case
 - Hermetically Sealed
 - Replacement for part number 2N884 thru 2N889 and 2N876 thru 2N881 devices.
 - TX, TXV, S-Level Screening Available. Consult Factory

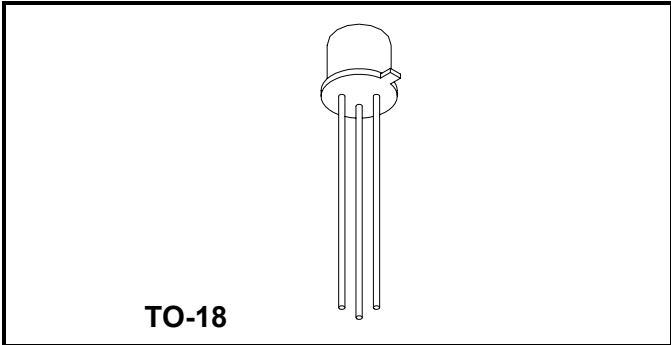

MAXIMUM RATINGS ($T_J = 25^\circ\text{C}$ UNLESS OTHERWISE NOTED, $R_{GK} = 1\text{K}\Omega$)		Symbol	Value	Units
Peak Repetitive Reverse Voltage and DC Blocking Voltage	SFS884	V_{DRM}	15	Volts
	SFS885		30	
	SFS886		60	
	SFS887	V_{RRM}	100	
	SFS888		150	
	SFS889		200	
Average On-State Current	$T_a = 30^\circ\text{C}$ $T_a = 100^\circ\text{C}$	$I_{F(AV)}$	0.5 0.35	Amps
Peak Recurrent Surge Current ($T_a \leq 100^\circ\text{C}$, $t_p = 0.2$ ms, duty cycle = 0.1 %)		I_{FSR}	20	Amps
Peak Gate Current		I_{GM}	250	mA
Peak Gate Voltage		V_{GM}	5	Volts
Operating Junction Temperature Range		T_J	-65 to +150	°C
Storage Temperature Range		T_{stg}	-65 to +150	°C

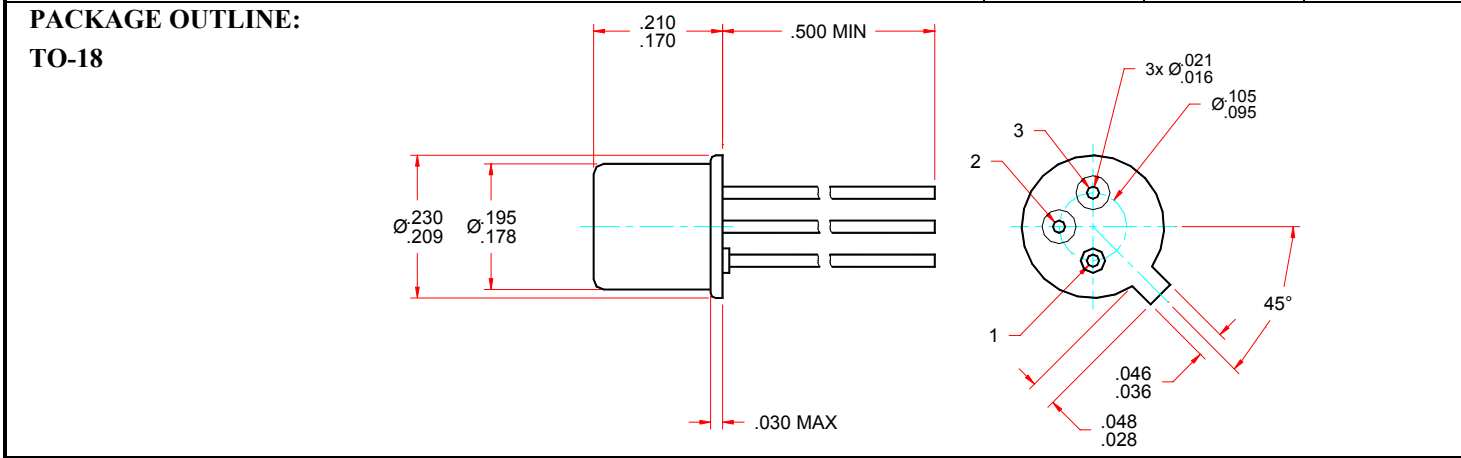



Solid State Devices, Inc.

14830 Valley View Blvd * La Mirada, Ca 90638
 Phone: (562) 404-7855 * Fax: (562) 404-1773
 ssdi@ssdi-power.com * www.ssdi-power.com

SFS884 thru SFS889

ELECTRICAL CHARACTERISTICS ($T_a = 25^\circ\text{C}$ unless otherwise indicated)		Symbol	Min	Typical	Max	Unit
Peak Reverse Blocking Current (Rated V_{RRM})	$T_j = 25^\circ\text{C}$ $T_j = 125^\circ\text{C}$	I_{RRM}	—	—	10 100	μA
Peak Forward Blocking Current (Rated V_{DRM})	$T_j = 25^\circ\text{C}$ $T_j = 125^\circ\text{C}$	I_{DRM}	—	—	10 100	μA
Peak On-State Voltage ($I_F = 0.2 \text{ A Peak}$)		V_{TM}	—	1.0	1.50	Volts
Reverse Gate Current ($V_G = -2 V_{DC}$, Anode = open)		I_{GR}	—	—	10	μA
Gate Trigger Current ($V_D = 12 V_{DC}$, $R_L = 33 \Omega$)		I_{GT}	—	50	80	μA
Gate Trigger Voltage ($V_D = 12 V_{DC}$, $R_L = 33 \Omega$)		V_{GT}	0.4	0.65	0.72	Volts
Holding Current ($I_T = 500 \text{ mA}$, Gate Open)		I_H	—	1.0	2.2	mA
Critical Rate of Voltage Rise (Linear slope up to $V_D = 67\%$ of V_{DRM} , $R_{gk} = 1\text{K}\Omega$)		dV/dt	—	750	—	V/μs
Commutated Turn-off Time ($I_f = 2\text{A}$, $I_g = 200 \text{ mA}$, $dI_g/dt = 0.1\text{A}/\mu\text{s}$)		t_{qt}	—	2	—	μs

NOTES:

1/ Unless Otherwise Specified, All Electrical Characteristics @ $T_C = 25^\circ\text{C}$, $R_{GK} = 1\text{K}\Omega$.

Available Part Numbers:
 SFS884, SFS885, SFS886, SFS887, SFS888, SFS889

PIN ASSIGNMENT (Standard)			
Package	Cathode	Gate	Anode
TO-18	Pin 1	Pin 2	Pin 3 (case)