

MA3Z551

Silicon epitaxial planar type

For high-frequency variable resistor attenuator

■ Features

- Small diode capacitance C_D
- Large variable range of forward dynamic resistance r_f
- Mini type package, allowing downsizing of equipment and automatic insertion through the taping package and magazine package

■ Absolute Maximum Ratings $T_a = 25^\circ\text{C}$

Parameter	Symbol	Rating	Unit
Reverse voltage (DC)	V_R	40	V
Peak reverse voltage	V_{RM}	45	V
Forward current (DC)	I_F	100	mA
Power dissipation	P_D	150	mW
Operating ambient temperature	T_{opr}	-25 to +85	$^\circ\text{C}$
Storage temperature	T_{stg}	-55 to +150	$^\circ\text{C}$

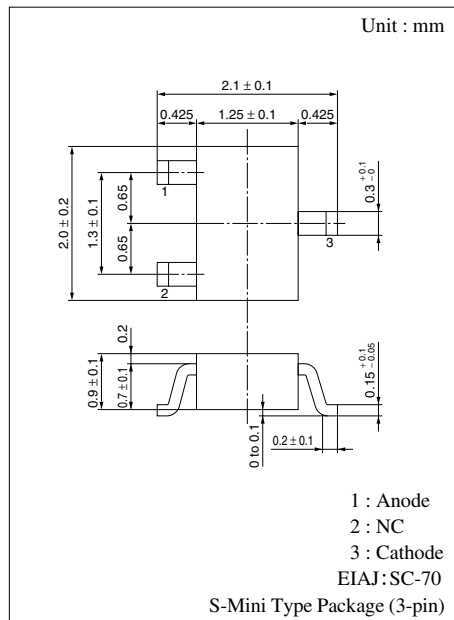

Marking Symbol: MY

Internal Connection

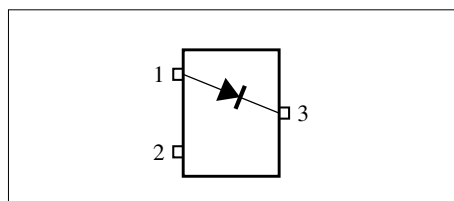

■ Electrical Characteristics $T_a = 25^\circ\text{C}$

Parameter	Symbol	Conditions	Min	Typ	Max	Unit
Reverse current (DC)	I_R	$V_R = 40\text{ V}$			100	nA
Forward voltage (DC)	V_F	$I_F = 100\text{ mA}$		1.05	1.2	V
Diode capacitance	C_D	$V_R = 15\text{ V}, f = 1\text{ MHz}$		0.3	0.5	pF
Forward dynamic resistance*	r_{f1}	$I_F = 10\ \mu\text{A}, f = 100\text{ MHz}$	1	2		k Ω
	r_{f2}	$I_F = 10\text{ mA}, f = 100\text{ MHz}$		6	10	Ω

Note) 1. Rated input/output frequency: 100 MHz

2. *: r_f measuring instrument: YHP MODEL 4191A RF IMPEDANCE ANALYZER

