

General Description

The ADT7350 is a step-down converter with integrated switching MOSFET. It operates wide input supply voltage range from 4.5V to 24V with 1.2A peak output current. It includes current limiting protection and thermal shutdown.

It reduces design complexity and external component count. The ADT7350 is available in small outline SOT23-6L package.

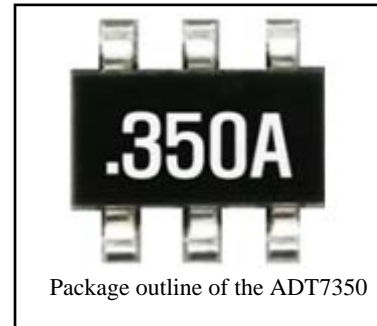

Features

- Current mode buck regulator with 1.4MHz fixed frequency
- Input voltage range : 4.5V to 24V
- Adjustable output range : 0.81V to 15V
- Max. output current : 1.2A
- Up to 92% Efficiency
- Internal Soft-Start Function
- Integrated Power MOSFET switch : 400mΩ
- Thermal shutdown & current limit protection
- SOT23-6L package

Applications

- Distributed Power Systems
- Surveillance Camera module
- Navigation
- Infra-Red LED Drivers

Typical Application Circuit

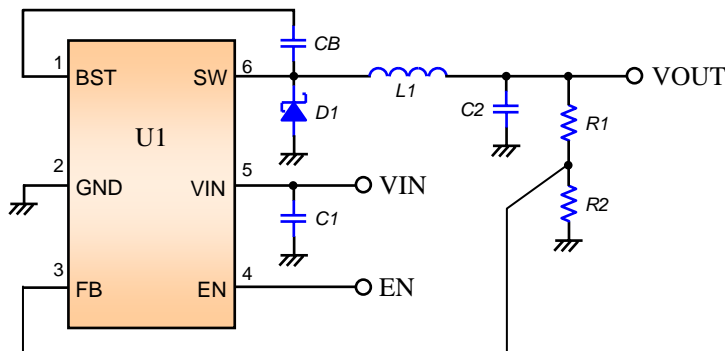

** This specifications are subject to be changed without notice*

Part List

Component	Type	Value (Model)	Manufacturer
U1	IC	ADT7350	ADTech
D1	Schottky barrier diode	RSX101M-30	ROHM
L1	Chip inductor	4.7uH / 1.6A	TDK
C2	MLCC	22 μ F / 16V	-
C1	MLCC	10 μ F / 50V	-
CB	MLCC	10nF	-
R1	Chip resistor	49.9k Ω / 1%	-
R2	Chip resistor	16.2k Ω / 1%	-

• R1,R2 : VOUT 3.3V typical case

Pin Description

Pin No.	Name	Pin Description
1	BST	Bootstrap. This pin acts as the power supply for internal Power Transistor driver. Connect a 10nF capacitor between this pin and SW pin.
2	GND	Ground and heat sink. Connect this pin to a large copper PCB area.
3	FB	Feedback voltage input. The voltage of this pin is regulated to 0.81V. The shielding in the PCB layout is option and connect resistor divider as close as possible.
4	EN	Chip enable input. The Enable voltage range is higher than 1.2V and disable voltage is lower than 0.4V.
5	VIN	Power supply input. The input bypass capacitor should be as close as GND pin.
6	SW	Switching node. The free-wheeling diode is connected between this pin and GND.

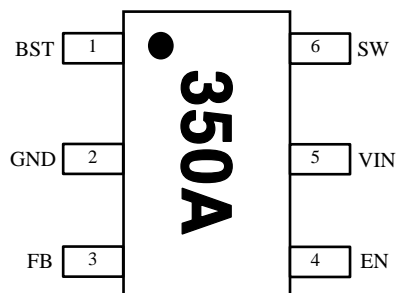

* This specifications are subject to be changed without notice

Functional Block Diagram

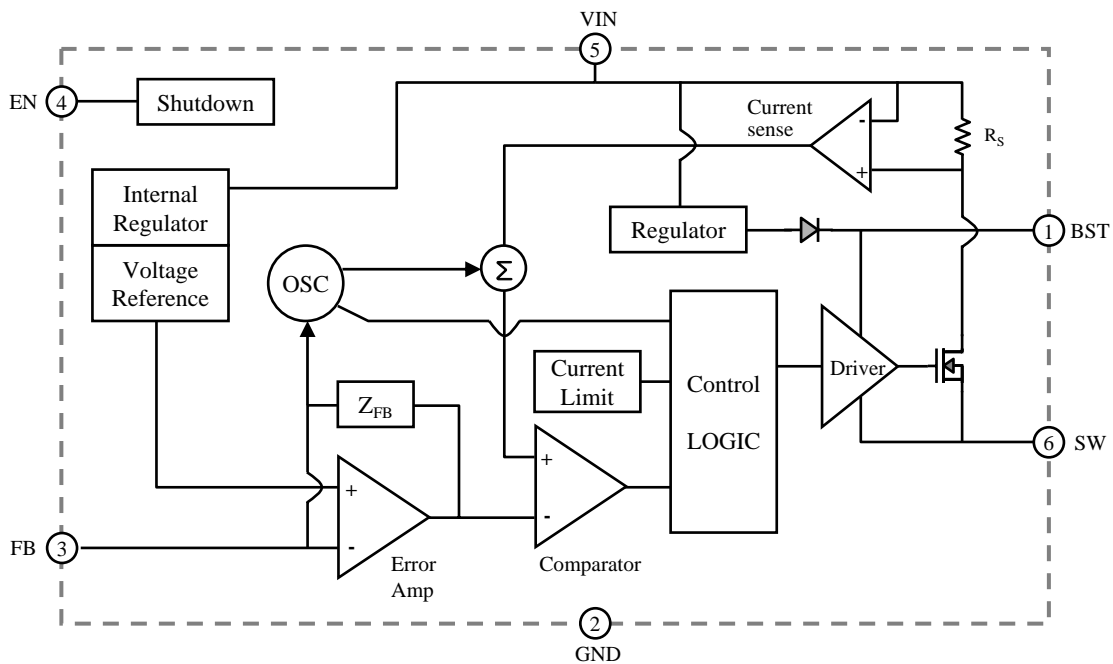

Absolute Maximum Ratings (Note1)

Parameter	Symbol	Min.	Typ.	Max.	Unit
Power supply voltage	V_{IN}	-	-	26	V
SW pin voltage	V_{SW}	-	-	27	V
BST pin voltage	V_{BST}	-	-	$V_{SW} + 6V$	V
All Other Pins	-	-0.3	-	+6	V
Max. power dissipation ($T_a=25^\circ C$) (Note2)	P_D	-	-	400	mW
Thermal resistance (Note3)	Θ_{JA}	-	250	-	$^\circ C/W$
Storage temperature	T_{STG}	-65	-	+150	$^\circ C$
Junction temperature	T_{Jmax}	-	-	+150	$^\circ C$

Note1. Stresses beyond those listed under "Absolute Maximum Ratings" may cause permanent damage to the device.

Note2. derate 4.0mW/ $^\circ C$ above +25 $^\circ C$. This is recommended to operate under this power dissipation specification.

Note3. Measured on JESD51-7, 4-layer PCB

Operating Ratings

Parameter	Symbol	Min.	Typ.	Max.	Unit
Power supply voltage	V_{IN}	4.5	12.0	24.0	V
Output voltage	V_{OUT}	0.81	-	15	V
Operating temperature	T_{OPR}	-40	-	+85	$^\circ C$
Junction temperature	T_J	-	-	+125	$^\circ C$

* This specifications are subject to be changed without notice

Electrical Characteristics (Ta=25°C, VIN=12V, unless otherwise noted)

Parameters	Condition	Min.	Typ.	Max.	Unit	Note
Supply current (shutdown)	$V_{EN} = 0V$	-	0.2	-	μA	
Supply current (quiescent)	$V_{EN} = 2V, V_{FB} = 1V$	-	-	1	mA	
Feedback voltage (V_{FB})	$4.5V \leq V_{IN} \leq 24V$	0.79	0.81	0.83	V	
Feedback current (I_{FB})	$V_{FB} = 0.81V$	-	0.1	-	μA	
Switch On Resistance ($R_{DS,ON}$), (Note5)	-	-	0.4	-	Ω	
Switch Leakage	$V_{EN} = 0V, V_{SW} = 0V$	-	-	30	μA	
Current Limit (Note5)	-	-	1.8	-	A	
Oscillator frequency (F_{SW})	$V_{FB} = 0.81V$	1.2	1.4	1.7	MHz	
Fold-back frequency	$V_{FB} = 0V$	-	460	-	kHz	
Maximum Duty cycle	$V_{FB} = 0.81V$	-	85	-	%	
UVLO rising threshold	-	3.8	4	4.2	V	
UVLO threshold hysteresis	-	-	250	-	mV	
EN input low voltage	-	-	-	0.4	V	
EN input high voltage	-	1.2	-	-	V	
EN input current	$V_{EN} = 2V$	-	5	-	μA	
	$V_{EN} = 0V$	-	0.1	-	μA	
Thermal shutdown (Note5)	-	-	140	-	$^{\circ}C$	

Note5. guaranteed by design.

** This specifications are subject to be changed without notice*

TYPICAL PERFORMANCE CHARACTERISTICS

$V_{IN}=12V$, $V_{OUT}=5V$, $L1=4.7\mu H$, $C1=10\mu F$, $C2=22\mu F$, $T_A=25^\circ C$, Unless otherwise mentioned

Efficiency vs. Load current

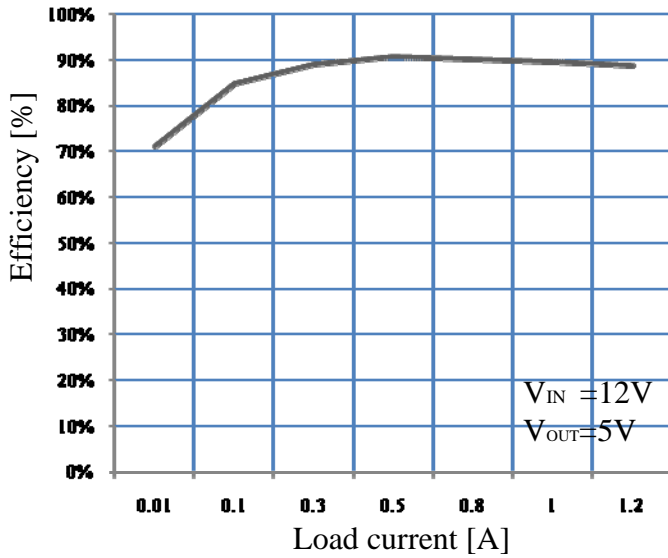

Efficiency vs. Load current

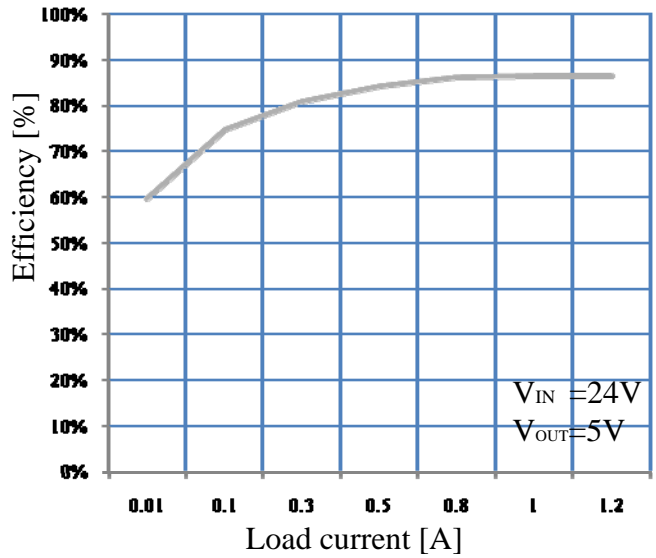

Switching Frequency versus Temperature

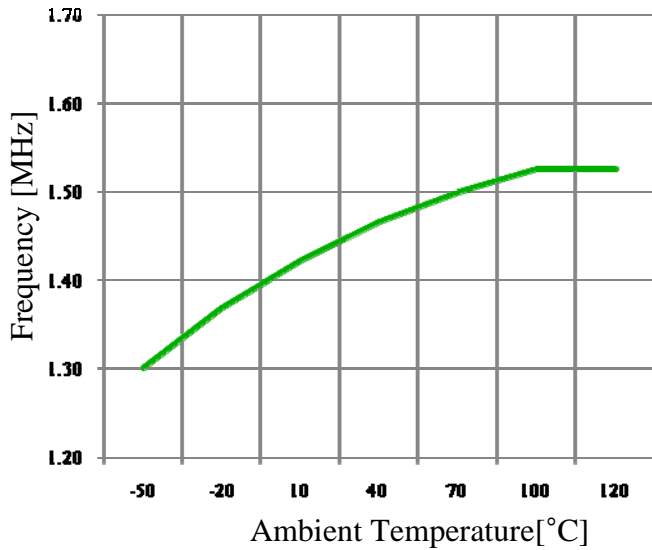

Feedback voltage versus Temperature

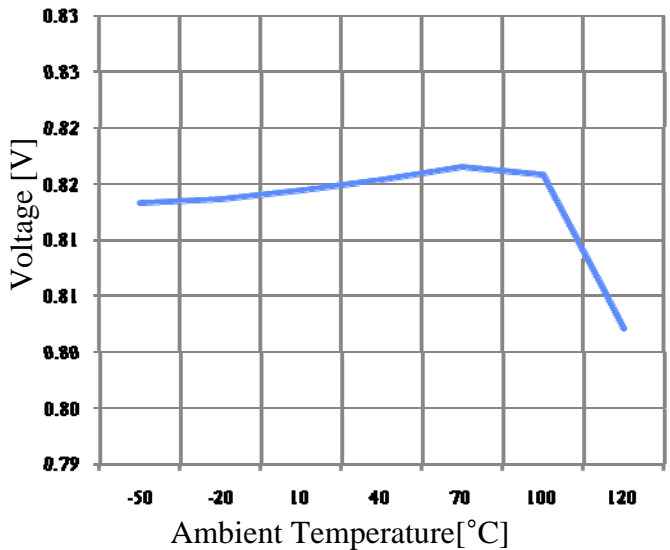

* This specifications are subject to be changed without notice

TYPICAL PERFORMANCE CHARACTERISTICS

$V_{IN}=12V$, $V_{OUT}=3.3V$, $L1=4.7\mu H$, $C1=10\mu F$, $C2=22\mu F$, $T_A=25^\circ C$, Unless otherwise noted

Transient Load Response

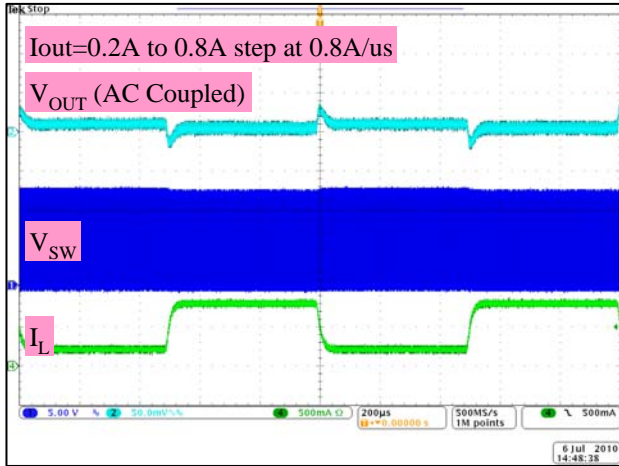

Start-up through Enable

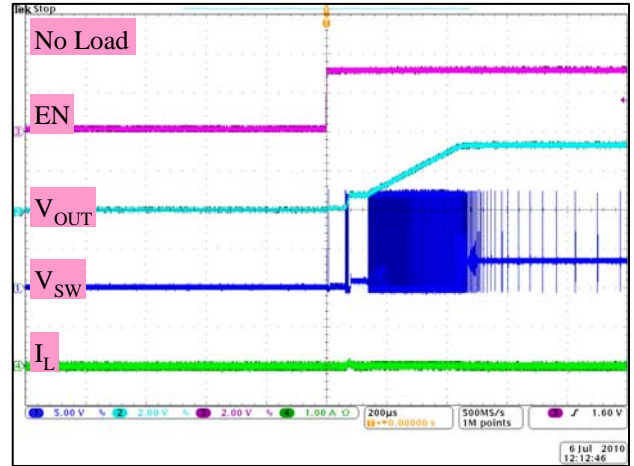

Shut down through Enable

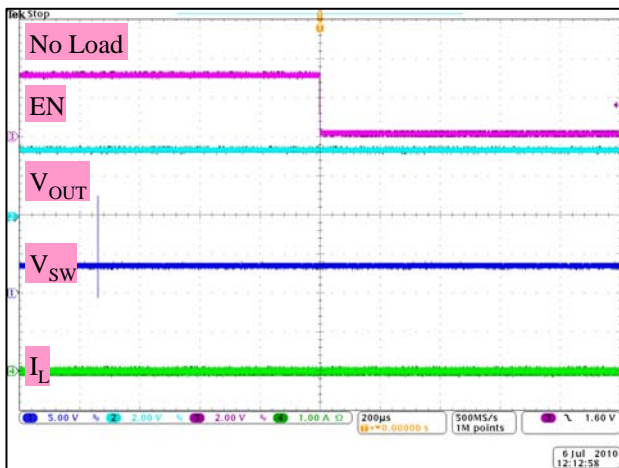

Start-up through Enable

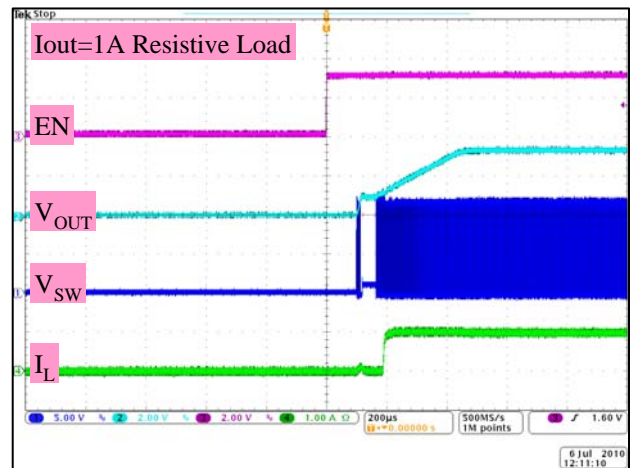

Shut down through Enable

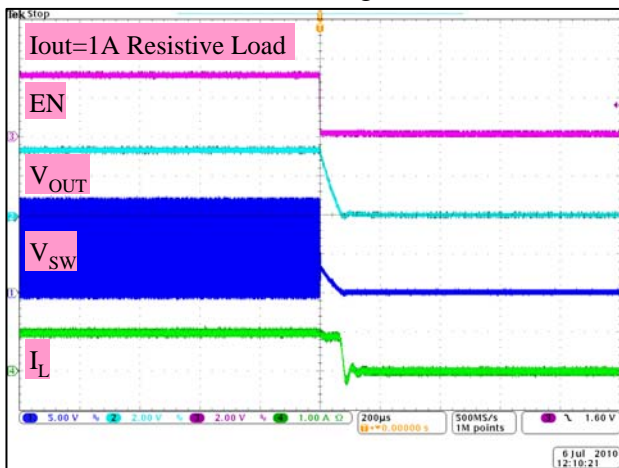

Dimming control

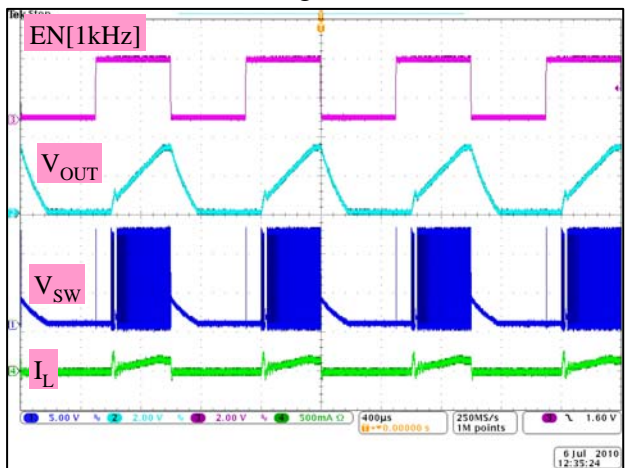

* This specifications are subject to be changed without notice

DETAILED DESCRIPTION

Architecture and Operation

The ADT7350 is a current mode step-down converter uses a PWM control and integrated Power Switch. An internal error amplifier establishes an integrated error voltage which is compared with slope compensated ramp signal in order to make internal Power Switch control signal. The ADT7350 has not only voltage feedback loop but also current feed-forward loop. The peak current detector limit the over current in cycle by cycle basis and gives the information of load current to the PWM controller.

At the starting of a cycle, Power Switch is off, the input and output is isolated. The fixed frequency generator start to operate. After oscillator working, every cycle of beginning, the Power Switch is turned on. The current flows into inductor thus input is shorted to output via to inductor.

The Power Switch is turned off when ;

- 1) The ramp signal which is the sum of the current sensing amplifier output and artificial compensated signal to prevent from sub-harmonic oscillation crosses the output of integrator .
- 2) The inductor current reaches the maximum allowed level (1.8A)
- 3) The protection signals are triggered.

When the Power Switch is off, the inductor current can not change abruptly. The external Schottky diode conducts the inductor current.

Enable(EN)

The ADT7350 features a low-power shut down mode to decrease total current consumption. A logic Low at EN shuts down the controller and internal Power Switch. The typical value of V_{IH} is 1.2V, V_{IL} is 0.4.

Soft-Start

The internal soft-start circuitry make a reference voltage of error amplifier gradually ramps up to reduce input surge current during start-up.

Bootstrap

In order to generate enough large control voltage of Power Switch. The purpose of this block is to decrease Power Switch turn on resistance.

Protection (OVP/OTP/OCP)

The ADT7350 monitors the output voltage of controller and limit the maximum allowed feedback voltage in order not to abruptly change output voltage. The output feed-back voltage over 0.95V, this function is triggered. The ADT7350 monitors the temperature variation using PTAT(Proportional to Absolute Temperature) current. When the die temperature exceeds typical +140 °C, the Over temperature function is triggered. The maximum allowed inductor current is well controlled to prevent from falling into over-load or shorted output conditions. The maximum allowed load current is typically 1.8A.

** This specifications are subject to be changed without notice*

DETAILED DESCRIPTION

UVLO (Under Voltage Lock Out)

ADT7350 can monitor the battery output voltage. If the battery output voltage is under 3.8V. The ADT7350 goes to the UVLO status to save the power consumption of applications.

Oscillator

The ADT7350 has a fixed frequency generator (typical 1.4MHz) and also automatically changes the operating frequency in accordance with feedback voltage (0.81V) for protecting the load. If the feedback voltage is under 0.4V, the operating frequency changes to one third of fixed operating frequency. (Typical 460KHz)

Error Amplifier

The high gain error amplifier integrate the error signal from which the difference of reference voltage and feedback voltage. The summed output Error signal compares with PWM Ramp signal. It provides accuracy of the voltage feedback loop regulation. The feedback voltage of ADT7350 is typical 0.81V.

Current sense Amplifier

The current sense amplifier output is proportional to the current flowing into the inductor. This output goes to the comparator to make a proper control signal. The ADT7350 has well compensated current slope which is added into ramp generator circuit.

Compensation Network

The fixed frequency peak current mode control scheme to provide easy compensation for stability and fast transient response. The cycle-by-cycle basis monitored peak current of inductor is compared with error amplifier output voltage. The duty cycle is modulated based on the inductor's peak current. The inductor can be emulated to current source. So the inductor's pole frequency goes to high frequency. It seems to be one-pole system. The ADT7350 has a inner compensation network in error amplifier block.

** This specifications are subject to be changed without notice*

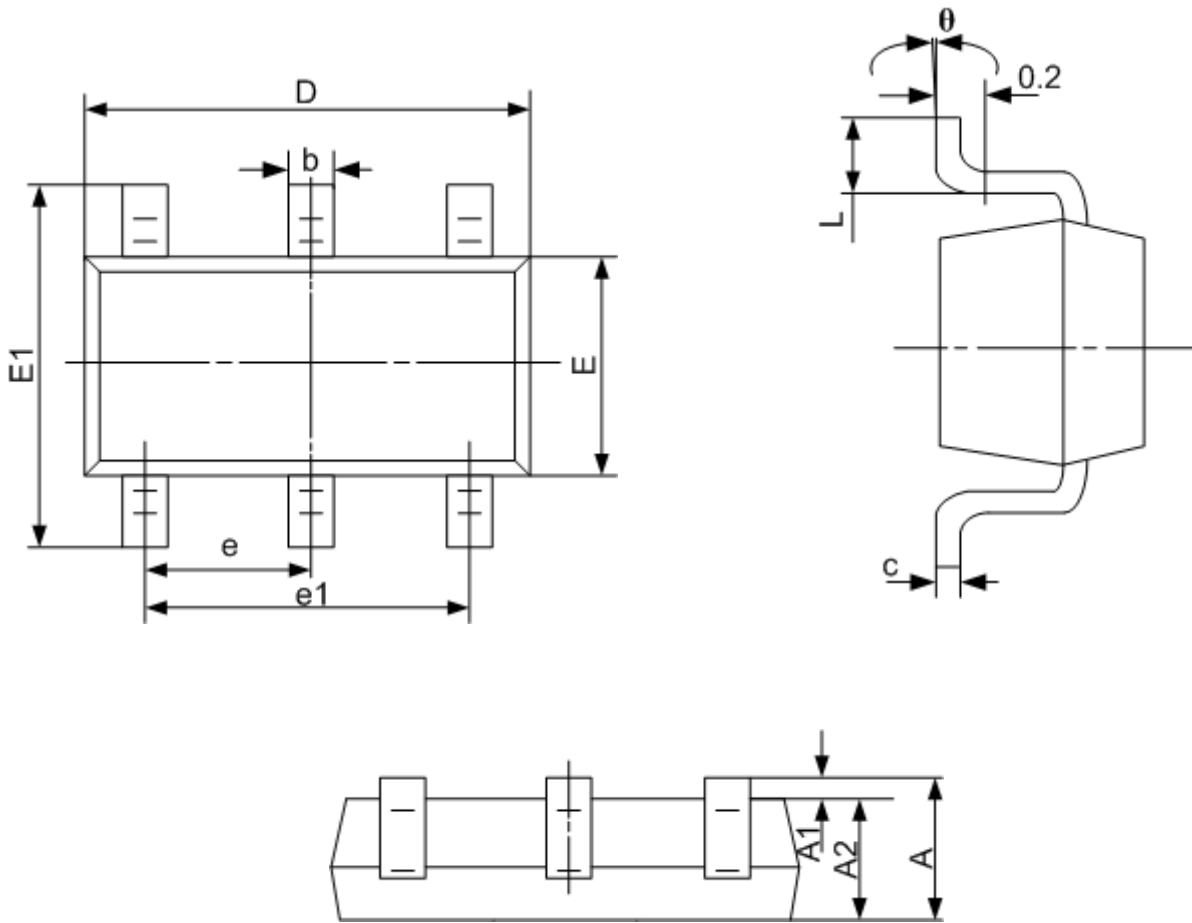
Package ; SOT23-6L

Symbol	Dimensions In Millimeters		Dimensions In Inches	
	Min	Max	Min	Max
A	1.050	1.250	0.041	0.049
A1	0.000	0.100	0.000	0.004
A2	1.050	1.150	0.041	0.045
b	0.300	0.500	0.012	0.020
c	0.100	0.200	0.004	0.008
D	2.820	3.020	0.111	0.119
E	1.500	1.700	0.059	0.067
E1	2.650	2.950	0.104	0.116
e	0.950(BSC)		0.037(BSC)	
e1	1.800	2.000	0.071	0.079
L	0.300	0.600	0.012	0.024
θ	0°	8°	0°	8°

* This specifications are subject to be changed without notice