

ACT 4455 / 4459

SINGLE SUPPLY TRANSCEIVERS

FOR MIL-STD-1553/1760

Features

- Single 5 Volt Supply Operation
- Low Power Dissipation
- Small Size & Light Weight
- Single Transceiver Save Space & Cost
- Outstanding MIL-STD-1553 performance
- Processed and Screened to Mil-STD-883 Specs
- Radiation Hard Dielectric Isolation Monolithic construction for Severe Environments
- Superior High Frequency Line Transient and Input Ripple Rejection
- Input and Output TTL Compatible Design
- DESC SMD# 5962-96741



General Description:

The Aeroflex Circuit Technology ACT4455 / 4459 series are next generation monolithic transceiver designs which provides full compliance with MIL-STD-1553A/B and 1760 requirements in the smallest packages with low power consumption and single power supply operation.

The ACT4455 / 4459 series performs the front-end analog function of inputting and outputting data through a transformer to the MIL-STD-1553 data bus.

Design of these transceivers reflects particular attention to active filter performance. This results in low bit and word error rate with superior waveform purity and minimal zero crossover distortion. Efficient transmitter electrical and thermal design provides low internal power dissipation and heat rise at high as well as low duty cycles.

Transmitter:

The Transmitter section accepts bi-phase TTL data at the input and when coupled to the data bus with a 1:2.5 ratio transformer, isolated on the data bus side with two 52.5 Ohm fault isolation resistors, and loaded by two 70 Ohm terminations, the data bus signal is typically 7.5 Volts P-P at A-A' (See Figure 5). When both DATA and $\overline{\text{DATA}}$ inputs are held low or high, the transmitter output becomes a high impedance and is "removed" from the line. In addition,

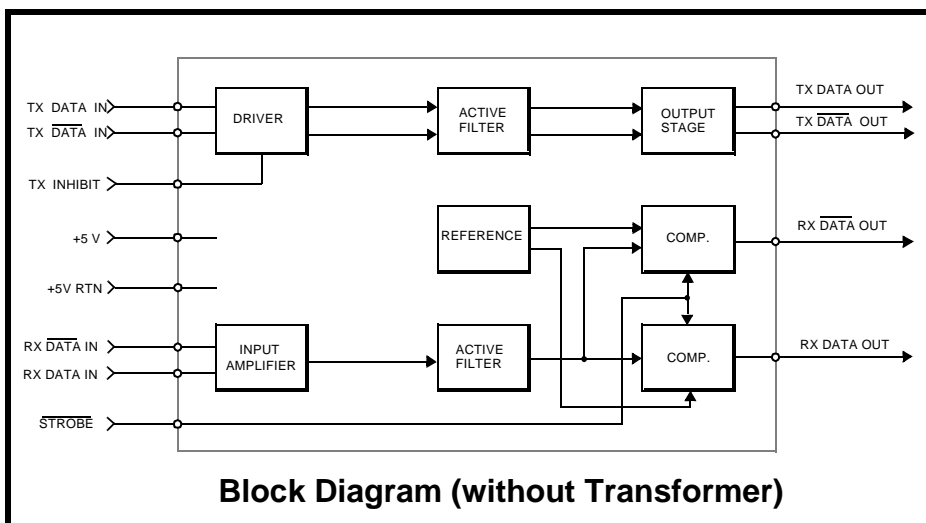

an overriding "INHIBIT" input provides for the removal of the transmitter output from the line. A logic "1" applied to the "INHIBIT" takes priority over the condition of the data inputs and disables the transmitter. (See Transmitter Logic Waveform, Figure 1.) The Transmitter may be safely operated for an indefinite period with the bus (point A-A') short circuited at 100% duty cycle.

Receiver:

The Receiver section accepts bi-phase differential data at the input

and produces two TTL signals at the output. The outputs are DATA and $\overline{\text{DATA}}$, and represent positive and negative excursions of the input beyond a pre-determined threshold. (See Receiver Logic Waveform, Figure 2.)

The pre-set internal thresholds will detect data bus signals exceeding 1.20 Volts P-P and reject signals less than 0.6 volts P-P when used with a transformer. (See Figure 5 for transformer data and typical connection.)

A low level at the Strobe input inhibits the DATA and $\overline{\text{DATA}}$ outputs. If unused, a 2K pull-up to +5 Volts is recommended

Figure 1 — Transmitter Logic Waveforms Idealized*

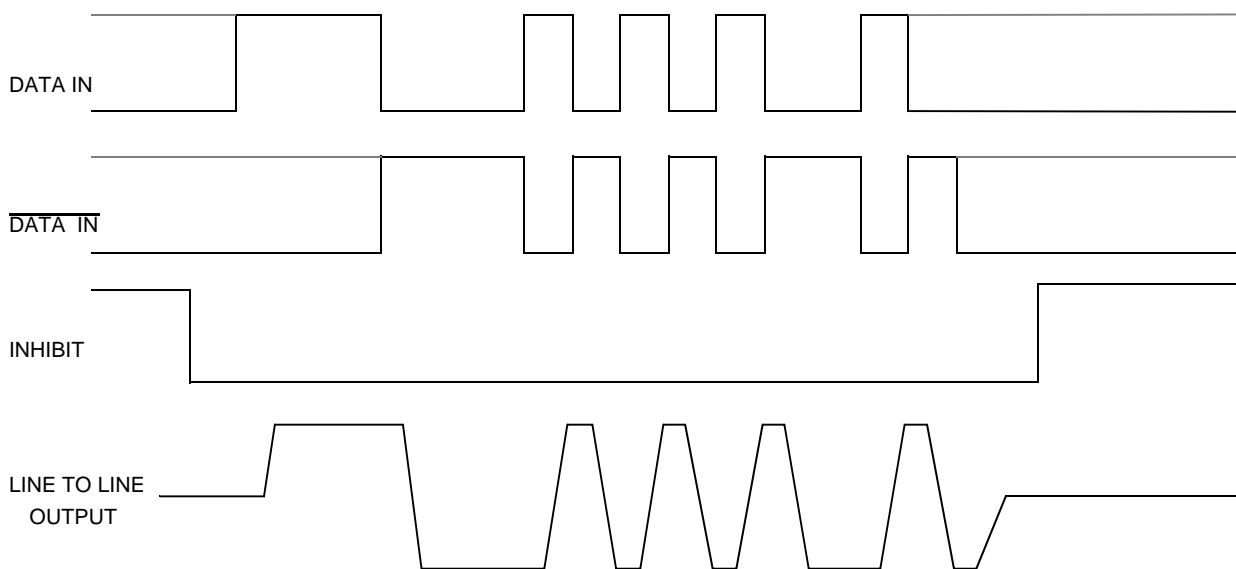

Note: DATA and $\overline{\text{DATA}}$ inputs must be complementary waveforms or 50% duty cycle average, with no delays between them, and must be in the same state during off times (both high or low).

Figure 2 — Receiver Logic Waveforms Idealized*

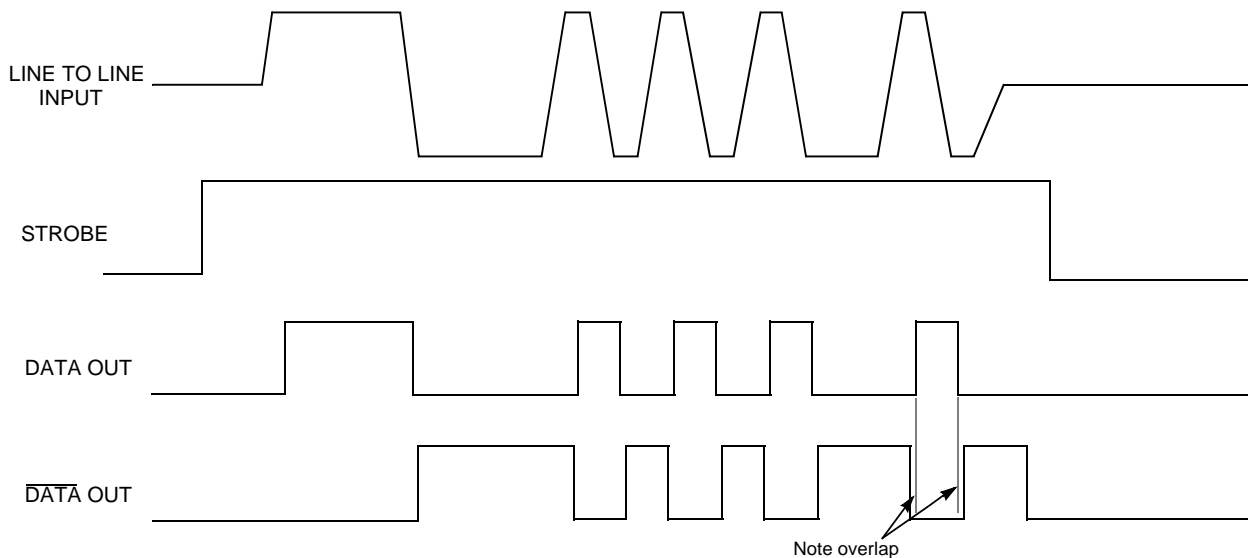

* See Figure 8 For Actual Waveforms

Absolute Maximum Ratings

Operating case temperature	-55°C to +125°C
Storage case temperature	-65°C to +150°C
Power supply voltage	-0.3 V to +7.0 V
Logic input voltage	-0.3 V to +5.5 V
Receiver differential input	±10 V
Receiver input voltage (common mode)	±5 V
Driver peak output current	600 mA
Total package power dissipation over the full operating case temperature rise	2 Watts (Note: Normal operation conditions require one transceiver on and the other off.)
Maximum junction to case temperature	10°C
Thermal resistance – junction to case	5°C/W

Electrical Characteristics — Driver Section

Input Characteristics, TX DATA in or TX $\overline{\text{DATA}}$ in (Notes 2 & 3 apply)

Parameter	Condition	Symbol	Min	Typ	Max	Unit
"0" Input Current	$V_{IN} = 0.4 \text{ V}$	I_{ILD}		-0.2	-0.4	mA
"1" Input Current	$V_{IN} = 2.7 \text{ V}$	I_{IHD}		1	40	μA
"0" Input Voltage		V_{ILD}			0.7	V
"1" Input Voltage		V_{IHD}	2.0			V

Inhibit Characteristics

"0" Input Current	$V_{IN}=0.4\text{V}$	I_{ILI}		-0.2	-0.4	mA
"1" Input Current	$V_{IN}=2.7\text{V}$	I_{IHI}		1.0	40	μA
"0" Input Voltage		V_{ILI}			0.7	V
"1" Input Voltage		V_{IHI}	2.0			V
Delay from TX inhibit, (0→1) to inhibited output		t_{DXOFF}		250	350	nS
Delay from TX inhibit, (1→0) to active output		t_{DXON}		150	250	nS
Differential output noise, inhibit mode		V_{NOI}		2	10	mV _{P-P}
Differential output impedance (inhibited)	Note 1	Z_{OI}	2K			Ω

Output Characteristics

Differential output level	$R_L=35 \Omega$	V_O	6	7.5	9	V_{P-P}
Rise and fall times(10% to 90% of P-P output)		t_r	100	200	300	nS
Output offset at point A-A' on Figure 5, 2.5μS after midpoint crossing of the parity bit of the last word of a 660μS message	$R_L=35 \Omega$	V_{OS}			± 90	mV peak
Delay from 50% point of TX DATA or TX $\overline{\text{DATA}}$ input to zero crossing of differential signal		t_{DTX}		120	250	nS

Note 1. Power on or off, measured from 75KHz to 1MHz at point A-A' and transformer self impedance of 3KΩ minimum

Electrical Characteristics — Receiver Section

Parameter	Condition	Symbol	Min	Typ	Max	Unit
Differential Receiver Input Voltage Range (See Figure 5, point P-P')	TXFMR 2.12:1	V_{IDR}		14	20	V_{P-P}
Common Mode Rejection Ratio (Note 3)		CMRR	45			dB

Strobe Characteristics (Logic "0" Inhibits Output)

"0" Input Current	$V_S=0.4\text{ V}$	I_{IL}		-0.2	-0.4	mA
"1" Input Current	$V_S=2.7\text{ V}$	I_{IH}		1	+40	μA
"0" Input Voltage		V_{IL}			0.7	V
"1" Input Voltage		V_{IH}	2.0			V
Strobe Delay (Turn-on or Turn-off)		t_{SD}		50	100	nS

Threshold Characteristics (Sinewave Input)

Input Threshold Voltage (referred to the bus)	100KHz–1MHz	V_{TH}	0.60	0.82	1.10	V_{P-P}
---	-------------	----------	------	------	------	-----------

Output Characteristics – RX DATA and RX $\overline{\text{DATA}}$

"1" State	$I_{OH} = -0.4\text{ mA}$	V_{OH}	2.5	3.7		V
"0" State	$I_{OL} = -4.0\text{ mA}$	V_{OL}		0.35	0.5	V
Delay, (average) from Differential Input Zero Crossings to RX DATA and RX $\overline{\text{DATA}}$ Output 50% points		t_{DRX}		340	500	nS

Power Data

Power Supply Currents – Per Channel

Transmitter Standby	Note 4	I_{CC}		18	30	mA
25% duty cycle				150	175	
50% duty cycle				300	350	
100% duty cycle				600	700	

Power Supply Voltage

Operating Power Supply Voltage Range		V_{CC}	+4.75	+5.00	+5.50	V
--------------------------------------	--	----------	-------	-------	-------	---

Note 2: $V_{CC} = 5\text{ Volts} \pm 0.1\text{ V}$, bypassed by 2.2 μF (Tantalum recommended) Capacitor minimum. All measurements & specifications apply over the temperature range of -55°C to +125°C (case temperature) unless otherwise specified.

Note 3: When measured at point A-A' with $\pm 10\text{ Volt}$ peak, line to ground, DC to 2MHz

Note 4: Typical power is measured with V_{BUS} at point A-A' = 7.5 V_{P-P}

Figure 3 – Transmitter (TX) Output Wave form

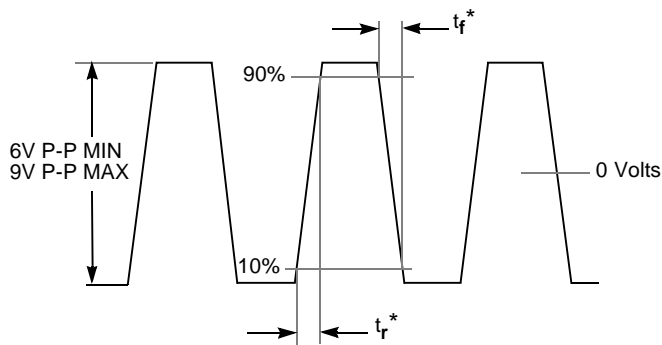

* Rise and fall times measured at point A-A' in Figure 5

Figure 4 – Transmitter (TX) Output offset

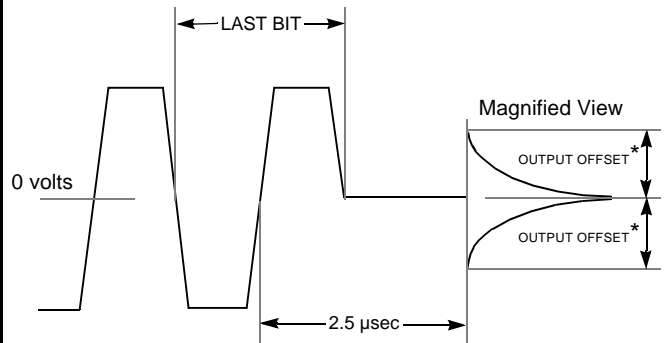

*Offset measured at point A-A' in Figure 5

Figure 5 – Typical direct transformer connection

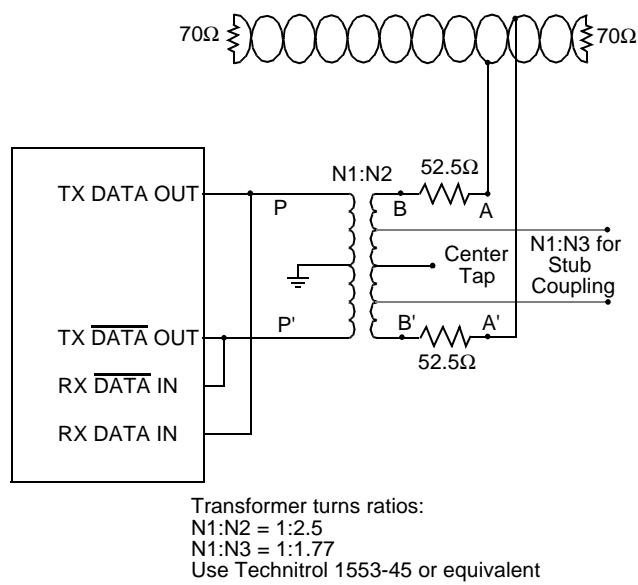
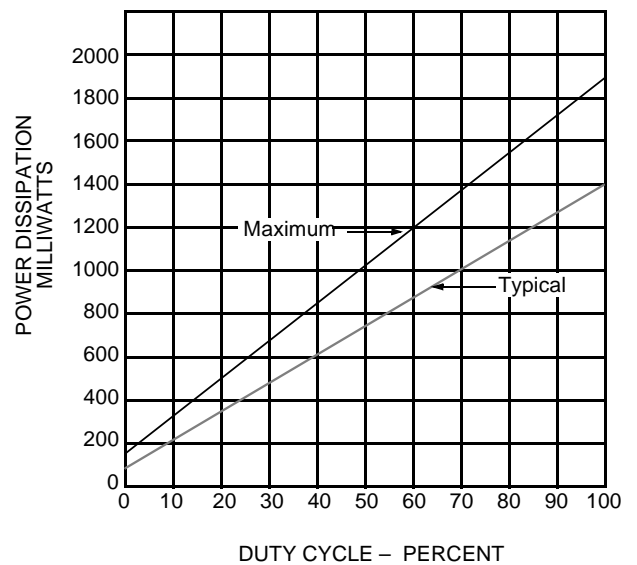

Figure 6 – Power Dissipation vs. Duty Cycle (Total hybrid with one channel transmitting and the other not powered)



Note: $V_{cc}=5$ Volts, Transformer ratio 1:2.5, V_{bus} (pt A-A') at 7.5 Volts P-P

Figure 8 ACTUAL HYBRID WAVEFORMS* — 25°C TYPICAL

START OF WORD – 33 WORD TRANSMISSION

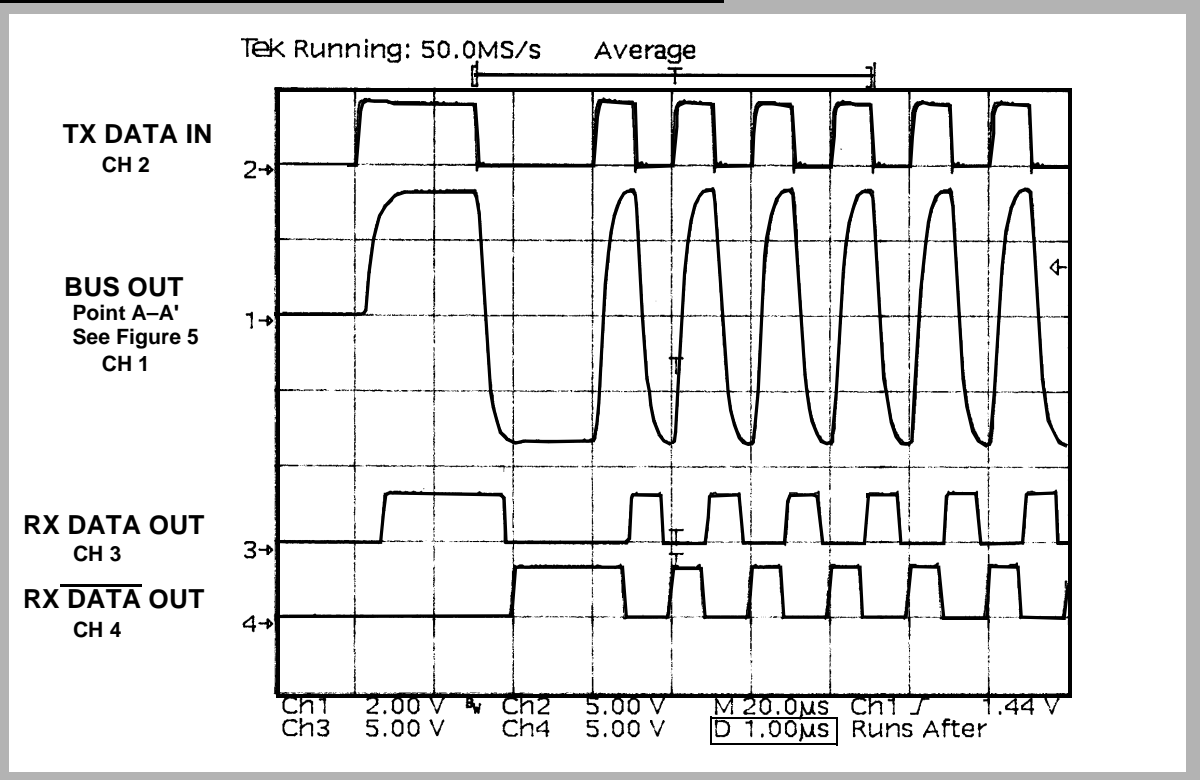

END OF WORD – 33 WORD TRANSMISSION

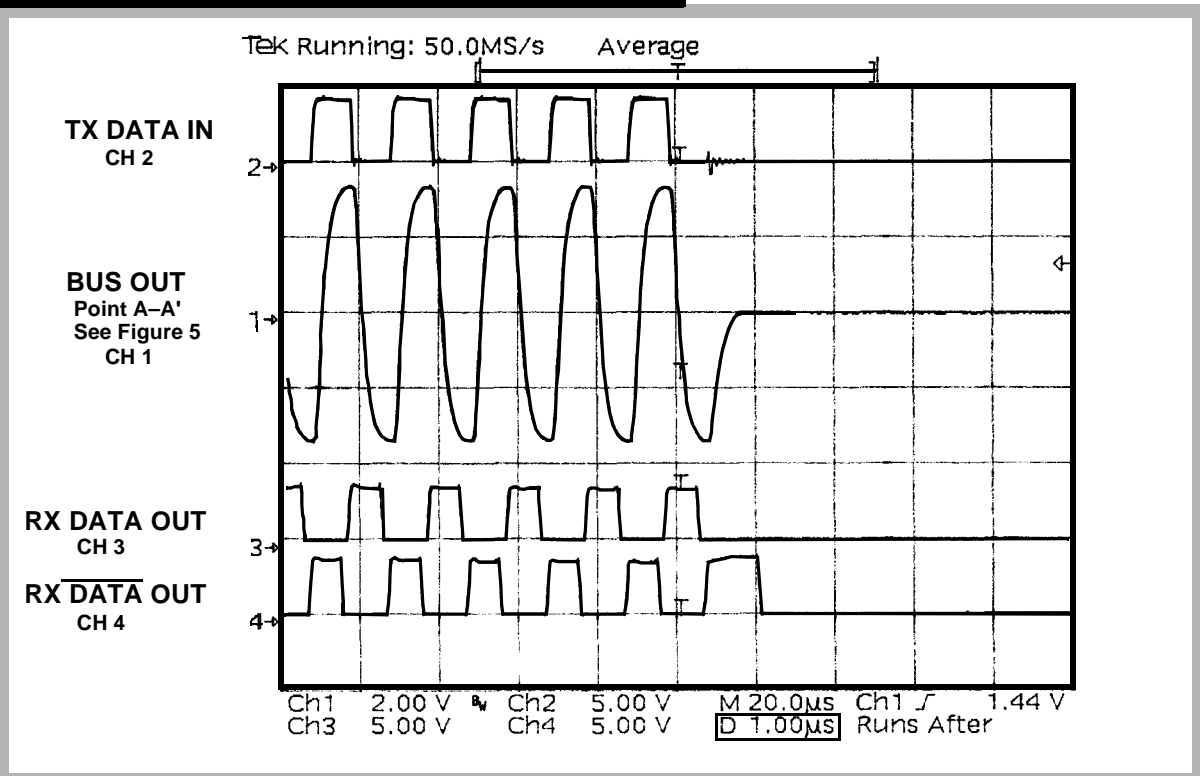

* Oscilloscope used is a TEK TDS540 with Probe 6139A.

Figure 7 – Pin Numbers & Functions

ACT4455/4459	
Pin #	Function
1	TX DATA OUT
2	+5V
3	+5V
4	TX DATA OUT
5	TX DATA OUT
6	GROUND 1
7	NC
8	NC
9	+5V
10	RX DATA OUT
11	STROBE
12	NC
13	RX DATA OUT
14	NC
15	+5V
16	GROUND 3
17	NC
18	RX DATA IN
19	RX DATA IN
20	NC
21	NC
22	GROUND 4
23	+5V
24	INHIBIT
25	TX DATA IN
26	TX DATA IN
27	GROUND 2
28	TX DATA OUT

Configurations and Ordering Information

Model No.	DESC No.	Receiver Data level	Case	Configuration
ACT 4455	5962-96741	Normally Low Rx	LCC	Single
ACT 4459	5962-96741	Normally High Rx	LCC	Single

ACT4455/4459 LCC LEADLESS CHIP CARRIER

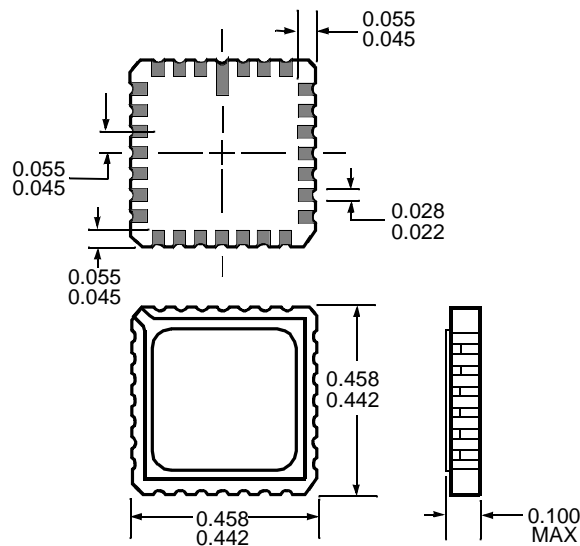

Notes

2. Pins are equally spaced at 0.100 ± 0.002 tolerance, non-cumulative, each row

Aeroflex Circuit Technology
35 South Service Road
Plainview New York 11830

Telephone: (516) 694-6700
FAX: (516) 694-6715
Toll Free Inquiries: 1-(800)THE-1553

Specifications subject to change without notice.