

Specifications

Maximum Ratings at $T_a = 25^\circ\text{C}$, $T_c = 25^\circ\text{C}$ unless otherwise specified

Parameter	Symbol	Conditions	Ratings	Unit
Operating substrate temperature	$T_c \text{ max}$	Recommended value is 105°C .	115	$^\circ\text{C}$
AC input voltage	V_{AC}	Specified test circuit	140	V_{rms}
Operating temperature	T_{opr}		-10 to +85	$^\circ\text{C}$
Storage temperature	T_{stg}		-30 to +115	$^\circ\text{C}$
Maximum output power	$W_o \text{ max}$	Specified test circuit, $V_O = 135\text{V}$	150	W
[TR1]				
Drain current	I_D	Refer to ASO characteristics for overcurrent condition.	8	A
Pulse drain current	$I_{D(pulse)}$		30	A
Drain reverse current	I_{DR}		8	A
Gate-source voltage	V_{GSS}		± 30	V
Allowable power dissipation	P_D		89.3	W
Chip junction temperature	$T_J \text{ max}$		150	$^\circ\text{C}$
Thermal resistance	θ_{j-c}		1.4	$^\circ\text{C/W}$
[ZD1]				
Allowable power dissipation	P_{ZD1}		500	mW
Chip junction temperature	$T_{J(ZD1)} \text{ max}$		125	$^\circ\text{C}$
Thermal resistance	$\theta_{j-c(ZD1)}$		0.2	$^\circ\text{C/mW}$

Recommended Operating Conditions at $T_a = 25^\circ\text{C}$

Parameter	Symbol	Conditions	Ratings	Unit
Pin 4 input voltage	V_4		± 8 to ± 24	V
Oscillator frequency	f_{osc}		20 to 120	kHz

Operating Characteristics at $T_a = 25^\circ\text{C}$, $T_c = 25^\circ\text{C}$ unless otherwise specified, specified test circuit

Parameter	Symbol	Conditions	min	typ	max	Unit
Output voltage setting		$I_n = 8\text{mA}$	40.0	40.5	41.0	V
Output voltage temperature coefficient		$T_c = 0$ to 105°C , $I_n = 8\text{mA}$	-	7	-	$\text{mV}/^\circ\text{C}$
[TR1]						
Drain-source breakdown voltage	$V_{(BR)DSS}$	$I_D = 10\text{mA}$, $V_{GS} = 0\text{V}$	500	-	-	V
Gate-source cutoff voltage	$V_{GS(off)}$	$I_D = 1\text{mA}$, $V_{DS} = 10\text{V}$	2.0	-	3.0	V
ON resistance	$R_{DS(on)}$	$I_D = 4.0\text{A}$, $V_{GS} = 10\text{V}$	-	0.8	1.1	Ω
Input capacitance	C_{iss}	$V_{DS} = 10\text{V}$, $V_{GS} = 0\text{V}$, $f = 1\text{MHz}$	-	1200	-	pF
[ZD1]						
Zener voltage	V_Z	$I_Z = 5\text{mA}$	23.7	-	26.3	V

Block Diagram

Pin Functions

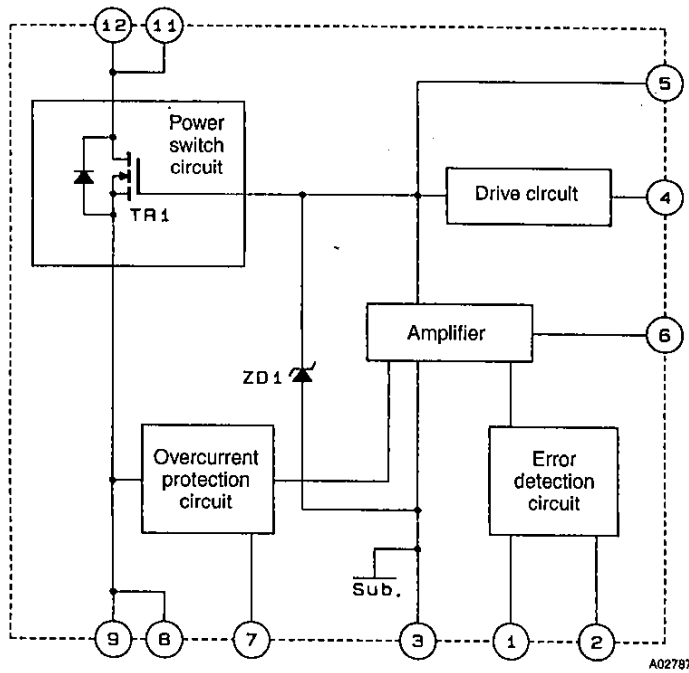

Pin No.	Function
1	V_{ref} (40.5V typ) input
2	Error detection level
3	Ground
4	Drive voltage input
5	TR1 gate
6	Amplifier circuit control
7	OCP setting level input
8	TR1 source
9	TR1 source
11	TR1 drain
12	TR1 drain

The back surface of the IC is not an insulator, and is effectively at pin 3 potential.

Series Organization

These devices form a series with varying output power ratings.

Type No.	Maximum ratings					Operating characteristics		
	V_{DSS} [V]	T_{stg} [°C]	$T_c \text{ max}$ [°C]	$T_j \text{ max}$ [°C]	I_D [A]	Input voltage [V]	Output power [W]	ON resistance [Ω]
STK730-010	500	-30 to +115	+115	+150	6.0	85 to 132	110	1.4
STK730-020					8.0		145	0.8
STK730-030					10.0		180	0.7
STK730-040					12.0		210	0.55
STK730-050					15.0		280	0.3
STK730-060	900				3.0	170 to 264	110	5.0
STK730-070					5.0		180	3.0
STK730-080					6.0		210	2.0
STK730-090					8.0		280	1.2

Circuit Function Diagram

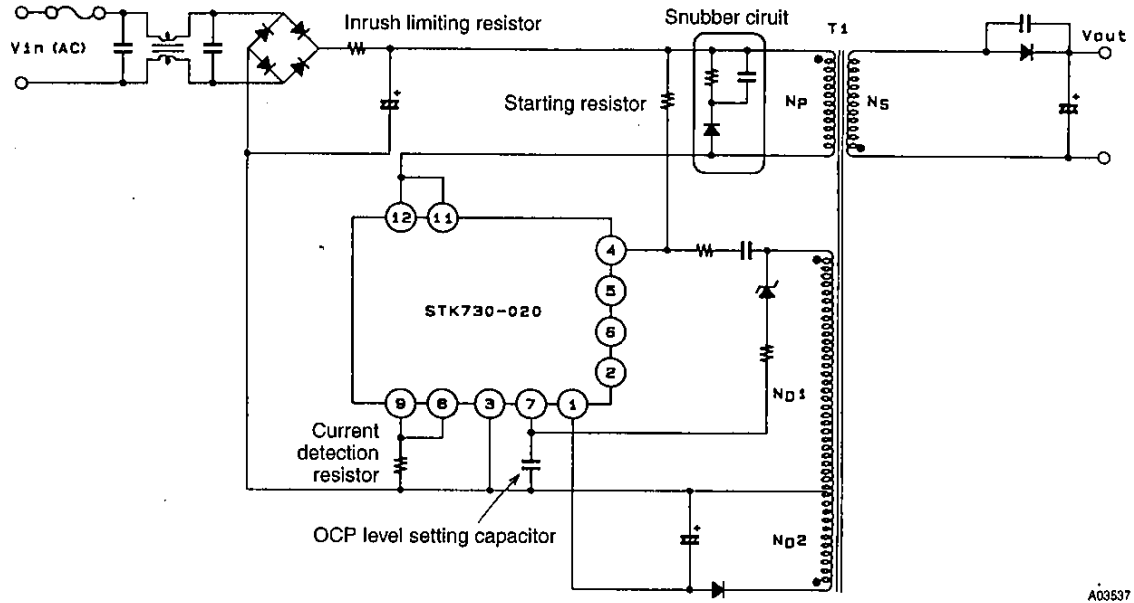

A03537

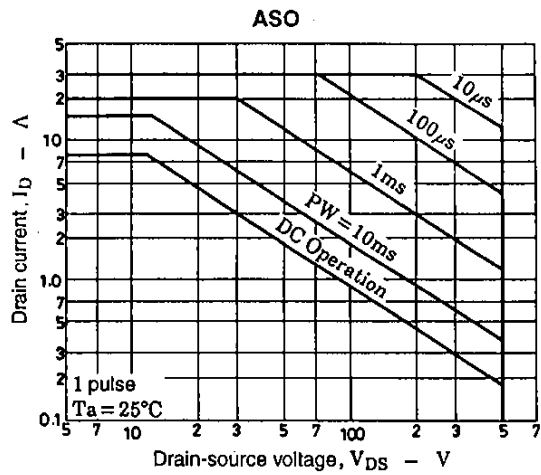
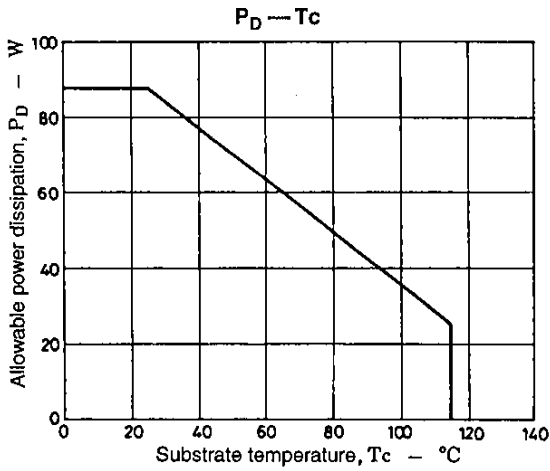

Sample Application Circuit

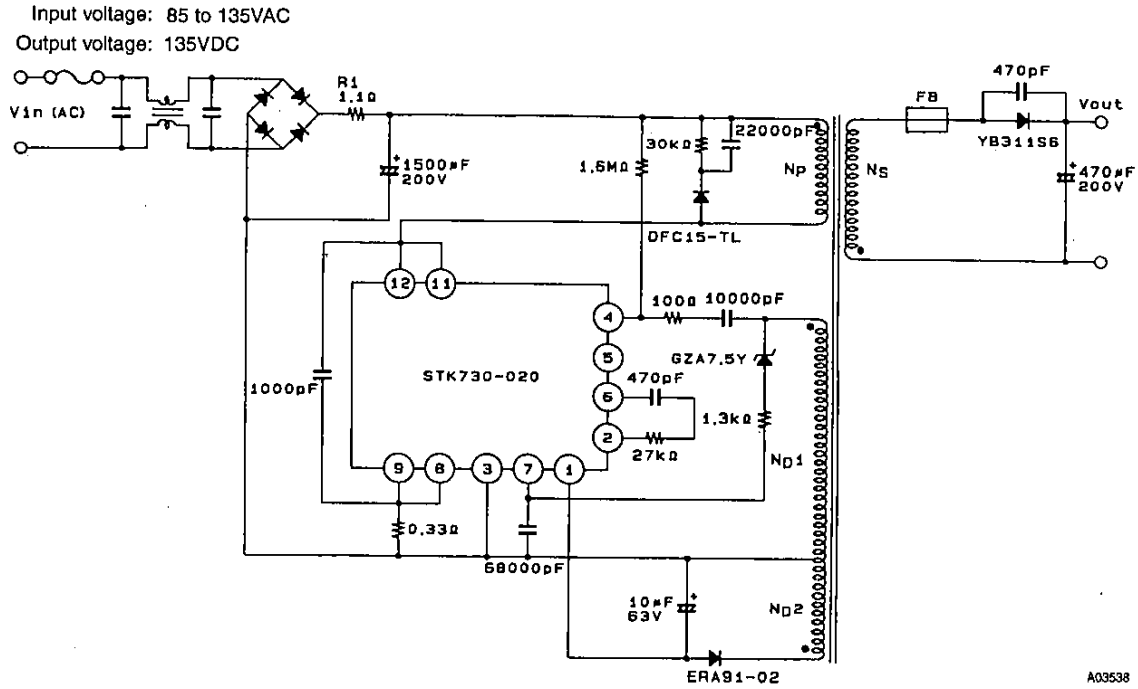

Pulse Transformer Specifications

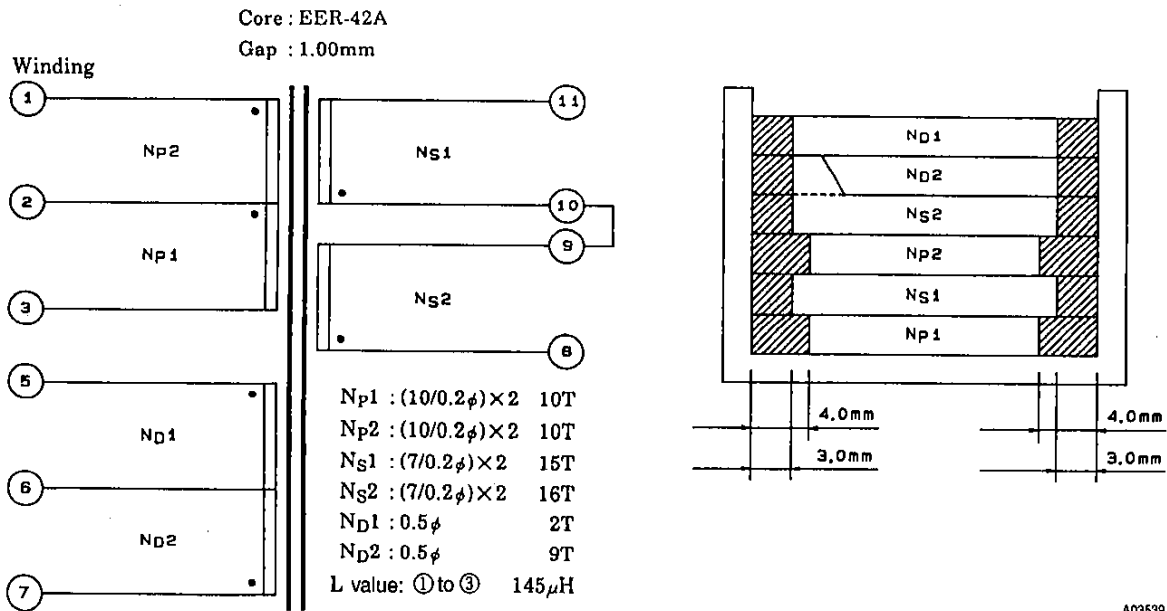

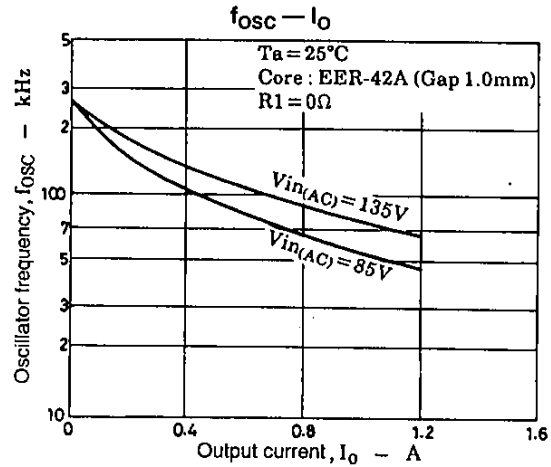
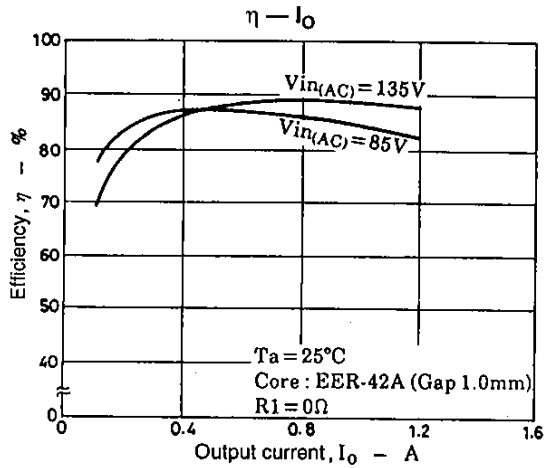
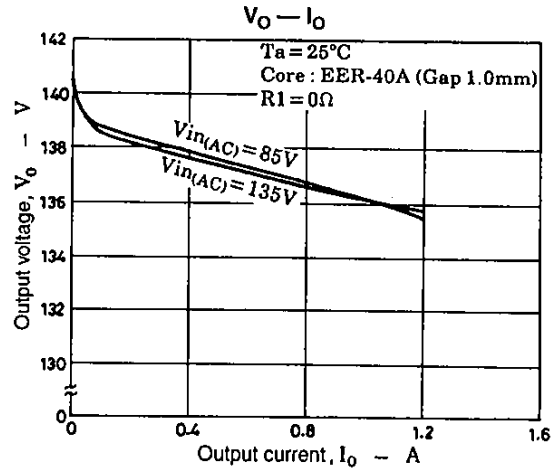
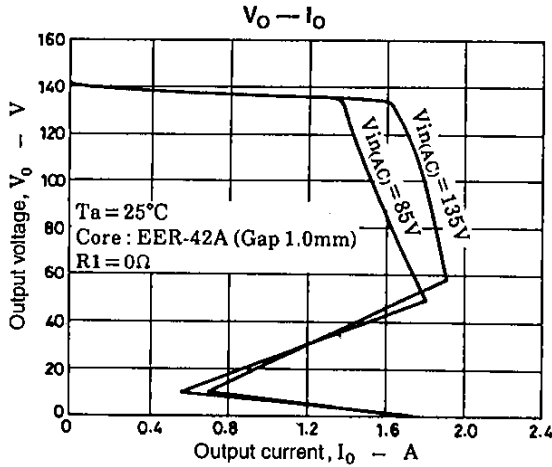

- No products described or contained herein are intended for use in surgical implants, life-support systems, aerospace equipment, nuclear power control systems, vehicles, disaster/crime-prevention equipment and the like, the failure of which may directly or indirectly cause injury, death or property loss.
- Anyone purchasing any products described or contained herein for an above-mentioned use shall:
 - ① Accept full responsibility and indemnify and defend SANYO ELECTRIC CO., LTD., its affiliates, subsidiaries and distributors and all their officers and employees, jointly and severally, against any and all claims and litigation and all damages, cost and expenses associated with such use:
 - ② Not impose any responsibility for any fault or negligence which may be cited in any such claim or litigation on SANYO ELECTRIC CO., LTD., its affiliates, subsidiaries and distributors or any of their officers and employees, jointly or severally.
- Information (including circuit diagrams and circuit parameters) herein is for example only; it is not guaranteed for volume production. SANYO believes information herein is accurate and reliable, but no guarantees are made or implied regarding its use or any infringements of intellectual property rights or other rights of third parties.

This catalog provides information as of June, 1995. Specifications and information herein are subject to change without notice.