



DEVICE NUMBER : DPT-255-033

REV : 1.2

ECN : _____

PAGE : 1/7

Phototransistor

MODEL NO : PT2559B/L2/F2

■ Features :

- Wide angle of half sensitivity $\theta = \pm 65^\circ$
- High sensitivity
- Fast response time
- Cutting Wavelength $\lambda_p = 840\text{nm}$

■ Description :

EVERLIGHT Dual Photo Transistor(PT2559B/L2/F2) is a high speed and high sensitivity dual photo transistor in a flat side view plastic package.

The epoxy package spectrally matched to IR emitter ($\lambda_p = 940\text{nm}$)

■ Applications :

- Mouse
- Optoelectronic Switch

PART NO.	CHIP	LENS COLOR
	MATERIAL	
PT	Silicon	Black

Phototransistor

 MODEL NO : PT2559B/L2/F2

■ Package Dimensions :

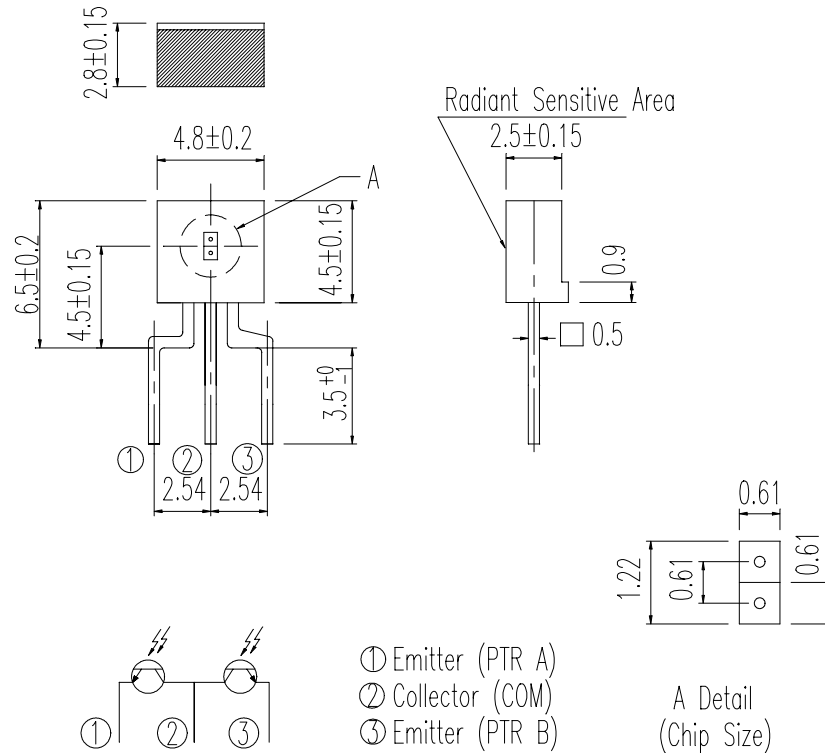

■ Notes :

1. All dimensions are in millimeter.
2. Lead spacing is measured where the lead emerge from the package.
3. Above specification may be changed without notice. EVERLIGHT will reserve authority on material change for above specification.
4. These specification sheets include materials protected under copyright of EVERLIGHT corporation . Please don't reproduce or cause anyone to reproduce them without EVERLIGHT's consent.
5. When using this product , please observe the absolute maximum ratings and the instructions for use outlined in these specification sheets. EVERIGHT assumes no responsibility for any damage resulting from use of the product which does not comply with the absolute maximum ratings and the instructions included in these specification sheets.
6. Lens color: Black transparent
7. Tolerance is ± 0.15 mm unless otherwise note.

**Phototransistor**MODEL NO : PT2559B/L2/F2**■ Absolute Maximum Ratings at T_a = 25°C**

Parameter	Symbol	Rating	Unit	Notice
Collector power dissipation (25°C Free Air Temperature)	P _d	75	mW	
C-E Voltage	V _{ce}	30	V	
E-C Voltage	V _{ec}	5	V	
Operating Temperature	T _{opr}	-25 ~ +85	°C	
Storage Temperature	T _{stg}	-40 ~ +85	°C	
Soldering Temperature (1/16 inch from body for 5 sec)	T _{sol}	260	°C	

■ Electronic Optical Characteristics :

Parameter	Symbol	Min.	Typ.	Max.	Unit	Condition
Collector dark current	I _{ceo}	0.16	0.4		nA	V _{ce} =10V , E _e =0mW/cm ²
C-E Saturation voltage	V _{ce(SAT.)}			0.4	V	I _c =2mA , I _B =100 μA
C-E Breakdown voltage	BV _{ceo}	30			V	I _c =1mA , E _e =0mW/cm ²
E-C Breakdown voltage	BV _{eco}	5			V	I _e =100 μA E _e =0mW/cm ²
On stat ecollector current	I _{c(ON)}	129		944	μA	E _e =0.555mW/cm ² , V _{ce} =5V
Rise Time	t _r		15		us	V _{ce} =5V I _c =0.5mA R _L =100Ω
Fall Time	t _f		15		us	



Phototransistor

MODEL NO : PT2559B/L2/F2

Typical Electrical/Optical/Characteristics Curves

Fig.1 Collector Power Dissipation vs. Ambient Temperature

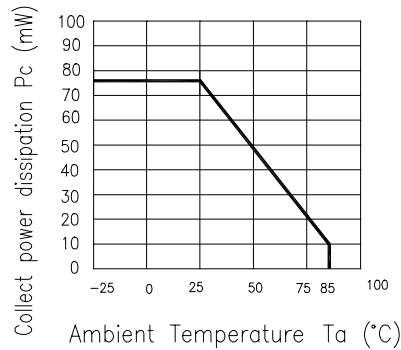

Fig.2 Collector Dark Current vs. Ambient Temperature

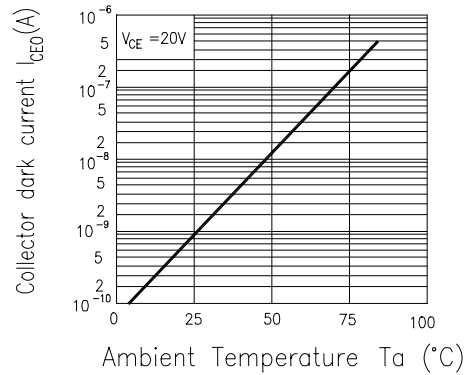

Fig. 3 Relative Collector Current vs. Ambient Temperature

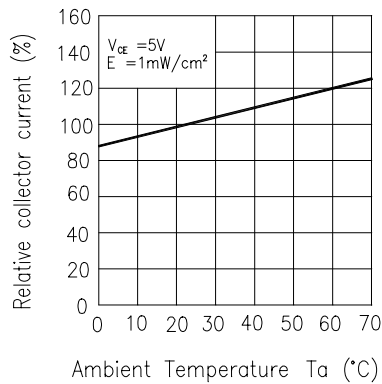

Fig.4 Collector Current vs. Irradiance

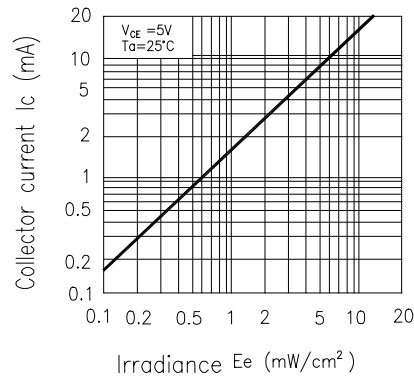

Fig.5 Spectral Sensitivity

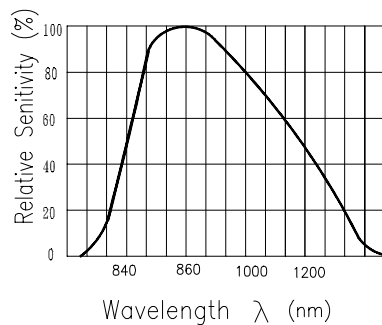
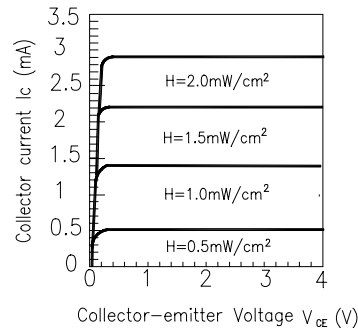

Fig.6 Collector Current vs. Collector-emitter Voltage





EVERLIGHT ELECTRONICS CO., LTD.

DEVICE NUMBER : DPT-255-033 REV : 1.2
 ECN : _____ PAGE : 5/7

Phototransistor

MODEL NO : PT2559B/L2/F2

■ Reliability Test Item And Condition

The reliability of products shall be satisfied with items listed below.

Confidence level:90%

LTPD:10%

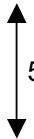
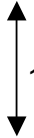
NO.	Item	Test Conditions	Test Hours/ Cycles	Sample Size	Failure Judgement Criteria	Ac/Re
1	Solderability	TEMP : 230°C ± 5 °C	5 secs	22 PCs	More than 90% of lead to be covered by soldering	0/1
2	Temperature Cycle	H : +85°C 30 mins  L : -55°C 30 mins	50 cycles	22 PCs	$I_R \geq U \times 2$ $E_e \leq L \times 0.8$ $V_F \geq U \times 1.2$	0/1
3	Thermal Shock	H : +100°C 5 mins  L : -10°C 5 mins	50 cycles	22 PCs	U :Upper specification limit L :Lower specification limit	0/1
4	High Temperature Storage	TEMP. : +100°C	1000 hrs	22 PCs		0/1
5	Low Temperature Storage	TEMP. : -55°C	1000 hrs	22 PCs		0/1
6	DC Operating Life	$I_F = 20\text{mA}$	1000 hrs	22 PCs		0/1
7	High Temperature / High Humidity	85°C / 85% R.H.	1000 hrs	22 PCs		0/1

Phototransistor

 MODEL NO : PT2559B/L2/F2

Test Method :

The Light current testing method for PTR:

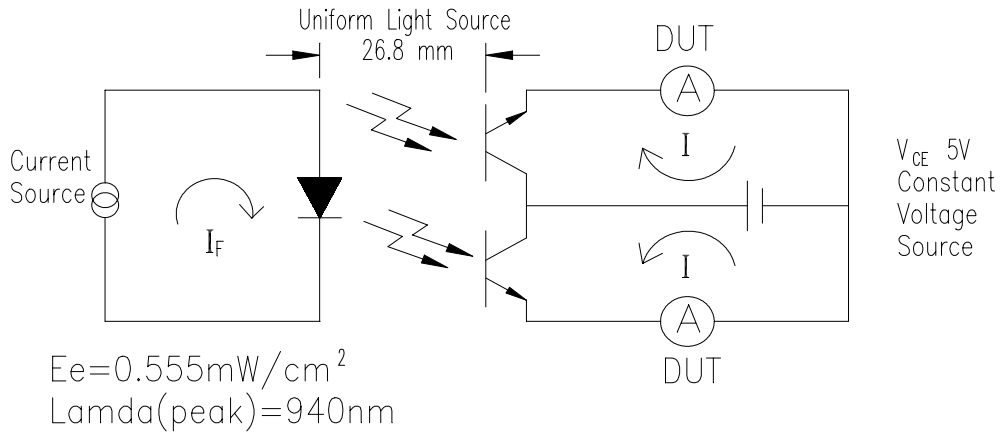

Ranking

Color Code	Parameter	Symbol	Min	Max	Unit	Test Condition
Red	A1	$I_{C(ON)}$	129	226	μA	$E_e = 0.555 \text{ mW/cm}^2$ $V_{CE} = 5\text{V}$
Blue	A2	$I_{C(ON)}$	195	306	μA	$E_e = 0.555 \text{ mW/cm}^2$ $V_{CE} = 5\text{V}$
Yellow	A3	$I_{C(ON)}$	262	380	μA	$E_e = 0.555 \text{ mW/cm}^2$ $V_{CE} = 5\text{V}$
Silver	A4	$I_{C(ON)}$	330	461	μA	$E_e = 0.555 \text{ mW/cm}^2$ $V_{CE} = 5\text{V}$
Green	A5	$I_{C(ON)}$	398	544	μA	$E_e = 0.555 \text{ mW/cm}^2$ $V_{CE} = 5\text{V}$
Purple	A6	$I_{C(ON)}$	468	625	μA	$E_e = 0.555 \text{ mW/cm}^2$ $V_{CE} = 5\text{V}$
White	A7	$I_{C(ON)}$	536	703	μA	$E_e = 0.555 \text{ mW/cm}^2$ $V_{CE} = 5\text{V}$
Brown	A8	$I_{C(ON)}$	604	785	μA	$E_e = 0.555 \text{ mW/cm}^2$ $V_{CE} = 5\text{V}$
Orange	A9	$I_{C(ON)}$	673	862	μA	$E_e = 0.555 \text{ mW/cm}^2$ $V_{CE} = 5\text{V}$
Gold	A10	$I_{C(ON)}$	742	944	μA	$E_e = 0.555 \text{ mW/cm}^2$ $V_{CE} = 5\text{V}$



Phototransistor

MODEL NO : PT2559B/L2/F2

■ Packing Specifications

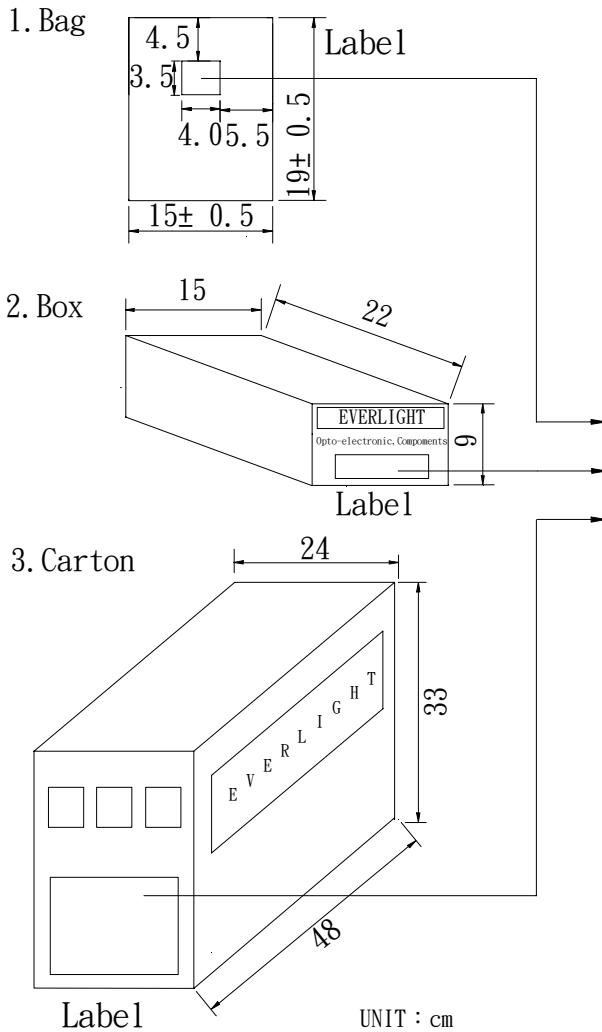
**EVERLIGHT**

CPN:

P/N: 3255290603



PT2559B/L2/F2

QTY:



LOT NO:

CAT:

HUE:

REF:

MADE IN TAIWAN

CPN : Customer's Production Number

P/N : Production Number

QTY : Packing Quantity

CAT : Ranks

HUE : Peak Wavelength

REF : Reference

LOT NO : Lot Number

MADE IN TAIWAN : Production place

■ Packing Quantity Specification

1. 500 Pcs / 1 Bag , 10 Bags / 1Box

2. 10 Boxes / 1Carton