

DATA SHEET

TEA7650H

Video signal processor for
CD-video/laser vision

Preliminary specification
File under Integrated Circuits, IC02

September 1990

Video signal processor for CD-video/laser vision

TEA7650H

FEATURES

- Modulation Transfer Function correction (MTF) at signal input for both standards
- HF drop out detector
- Data slicer, data output for program information (IEC standards)
- Separation of signals for Electronic Time Base Correction (ETBC)
- Noise reduction with chrominance trap, noise level adjust point
- Dynamic picture insertion and 6 dB video attenuation of main picture
- Bandgap reference voltage output, suitable for CCD delay line

GENERAL DESCRIPTION

Bipolar IC for video signal processing used in CD-Video/LaserVision players.
Standard PAL respectively NTSC output signal (CVBS). MTF amplifier.
FM-demodulator followed by de-emphasis stage.
PAL/NTSC switch for switching the MTF and de-emphasis.
Drop out detector with drop out switch, also externally switchable.
+5 volt supply, only 325 mW total power dissipation.

QUICK REFERENCE DATA

SYMBOL	PARAMETER	MIN.	TYP.	MAX.	UNIT
V_P	supply voltage (pins 12, 30, 47)	–	5	–	V
I_P	total supply current	–	–	65	mA
$V_{i(p-p)}$	FM input signal at pin 7 (peak-to-peak value)	50	–	300	mV
$V_{o(p-p)}$	CVBS output signal for CCDs (peak sync – peak white, pin 29)	–	850	–	mV
V_{29}	black level voltage (pin 29)	–	1.85	–	V
$V_{i(p-p)}$	delayed CVBS input signal for drop out path at pin 27 (peak-to-peak value)	–	700	–	mV
$V_{i(p-p)}$	delayed CVBS input signal at pin 31 from ETBC path (peak-to-peak value)	–	600	–	mV
$V_{o(p-p)}$	main CVBS output signal at pin 42 (peak-to-peak value)	–	1	–	V
V_{42}	black level voltage (pin 42)	–	2.2	–	V
$V_{o(p-p)}$	chrominance output signals at pins 44, 48 (peak-to-peak value)				
	PAL (burst)	–	760	–	mV
	NTSC (burst)	–	725	–	mV
V_{ref}	reference output voltage (pin 41)	–	1.6	–	V

ORDERING AND PACKAGE INFORMATION

EXTENDED TYPE NUMBER	PACKAGE			
	PINS	PIN POSITION	MATERIAL	CODE
TEA7650H	48	QFP48	plastic	SOT196A ⁽¹⁾

Note

1. SOT196-1; 1996 November 25.

Video signal processor for CD-video/laser vision

TEA7650H

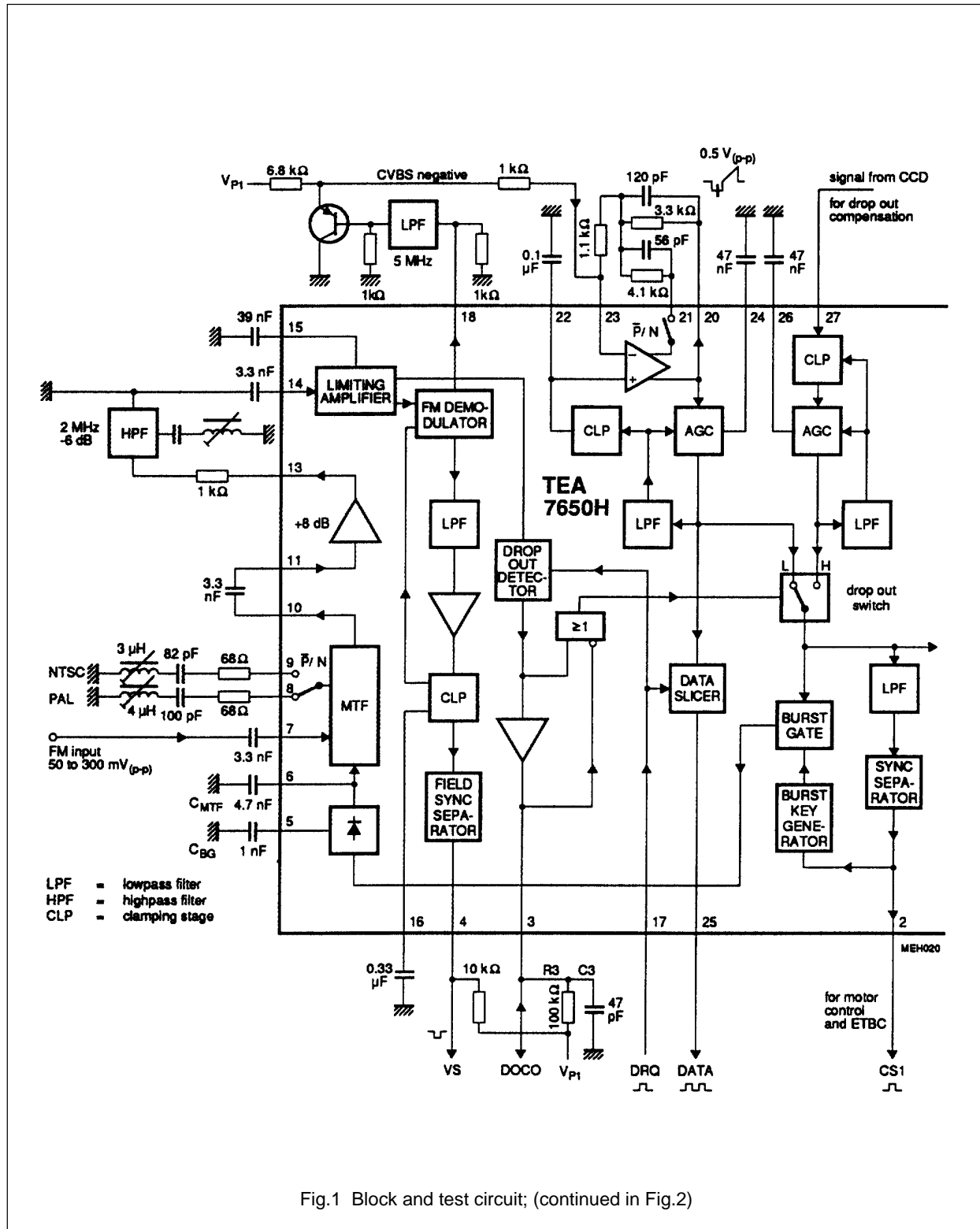

Video signal processor for CD-video/laser vision

TEA7650H

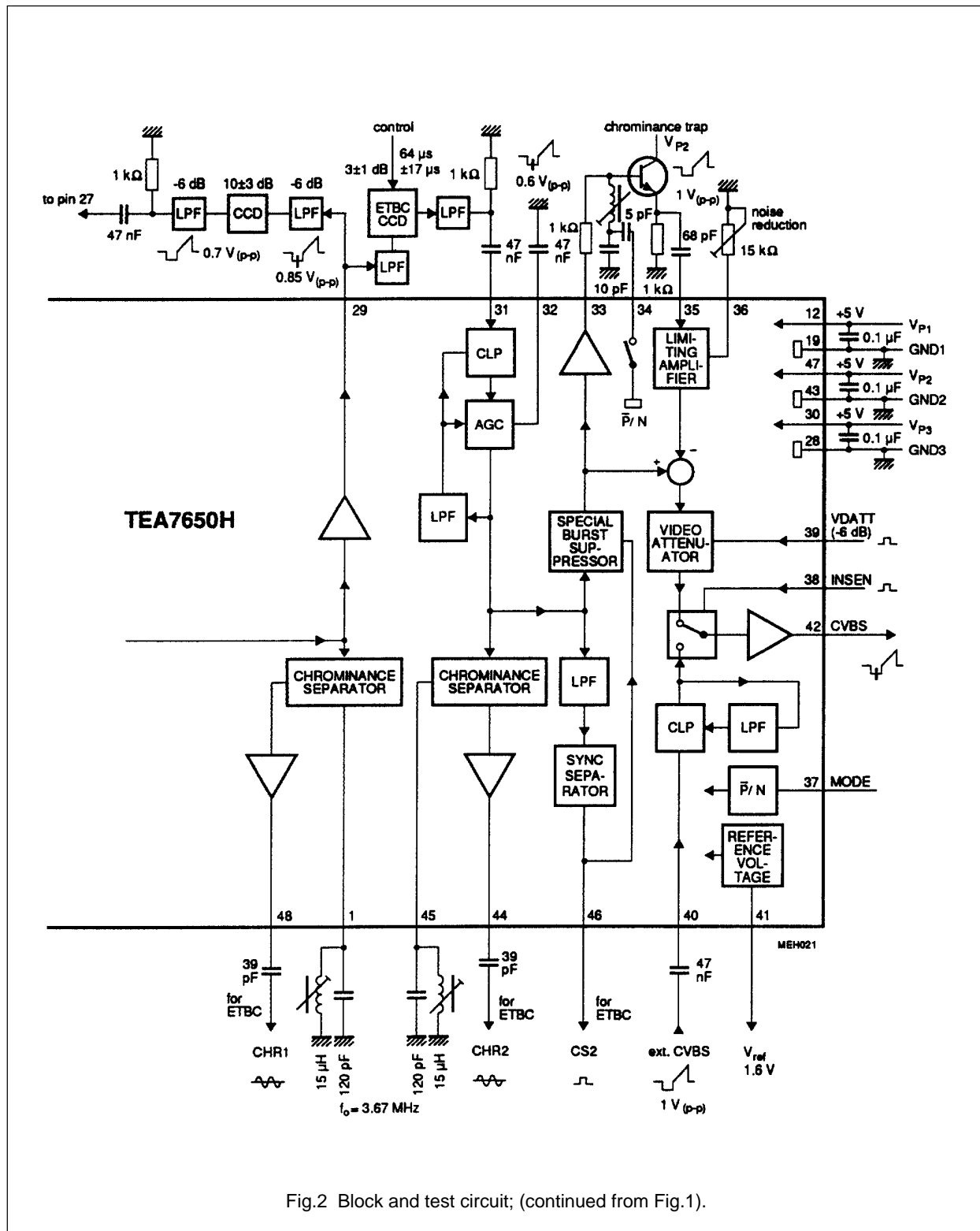

Fig.2 Block and test circuit; (continued from Fig.1).

Video signal processor for CD-video/laser vision

TEA7650H

PINNING

SYMBOL	PIN	DESCRIPTION
CRSC1	1	3.67 MHz resonant circuit 1
CS1	2	line synchronization output pulse 1 (composite sync)
DOCO	3	drop out control, input/output for external control
VS	4	field sync output
C _{BG}	5	charging capacitor for burst rectifier
C _{MTF}	6	charging capacitor for MTF control voltage
FM-IN	7	FM input signal from preamplifier
FREF1	8	PAL resonant circuit for the MTF
FREF2	9	NTSC resonant circuit for the MTF
MTFO	10	MTF output signal (corrected FM signal)
AMPIN	11	input for 8 dB amplifier (FM signal)
V _{P1}	12	+5 V supply (referred to pins 6 to 15 and 18)
AMPO	13	output of 8 dB amplifier (FM signal)
LIMIN1	14	limiter amplifier input (FM signal to demodulator)
C _{LIM}	15	capacitor for slicing level control of limiter
C _{DEM}	16	capacitor for clamping level of FM demodulator
DRQ	17	data request input for data at pin 25
DEMO	18	FM demodulator output (CVBS negative)
GND1	19	ground (0 V) for V _{P1}
FBO1	20	feedback output at PAL and NTSC (de-emphasis)
FBO2	21	feedback output, additional at NTSC (de-emphasis)
C _{CVBS}	22	capacitor for clamping of CVBS amplifier
DEEMI	23	de-emphasis input for CVBS from demodulator
C _{AGC1}	24	capacitor for AGC of CVBS amplifier
DATA	25	data output of information code
C _{AGC2}	26	capacitor for AGC of drop out amplifier
PRLIN	27	input signal of preceding line from CCD delay
GND3	28	ground (0 V) for V _{P3}
DOSW	29	drop out switch buffer output (to CCD delay and ETBC)
V _{P3}	30	+5 V supply (referred to pins 5, 17, 20 to 36, 38 to 42)
VIDIN	31	CVBS input signal from ETBC
C _{AGC3}	32	capacitor for AGC of CVBS follower amplifier
VIBUF	33	video signal buffer output to chroma trap circuitry
FTRAP	34	switching output for chroma trap at NTSC
LIMI2	35	limiter amplifier input for noise reduction
NRADJ	36	noise level adjust point (resistor to ground)
MODE	37	standard select input PAL/NTSC (PAL = LOW)
INSEN	38	insertion enable input
VDATT	39	6 dB CVBS attenuation (active HIGH)
EXVID	40	external CVBS input for insertion

Video signal processor for CD-video/laser vision

TEA7650H

SYMBOL	PIN	DESCRIPTION
V _{ref}	41	reference voltage output (1.6 V)
CVBS	42	main CVBS output signal
GND2	43	ground (0 V) for V _{P2}
CHR2	44	chrominance output signal 2
CRSC2	45	3.67 MHz resonant circuit 2
CS2	46	line synchronization pulse 2 (composite sync)
V _{P2}	47	+5 V supply (referred to pins 1 to 4, 16, 37, 43 to 48)
CHR1	48	chrominance output signal 1

PIN CONFIGURATION

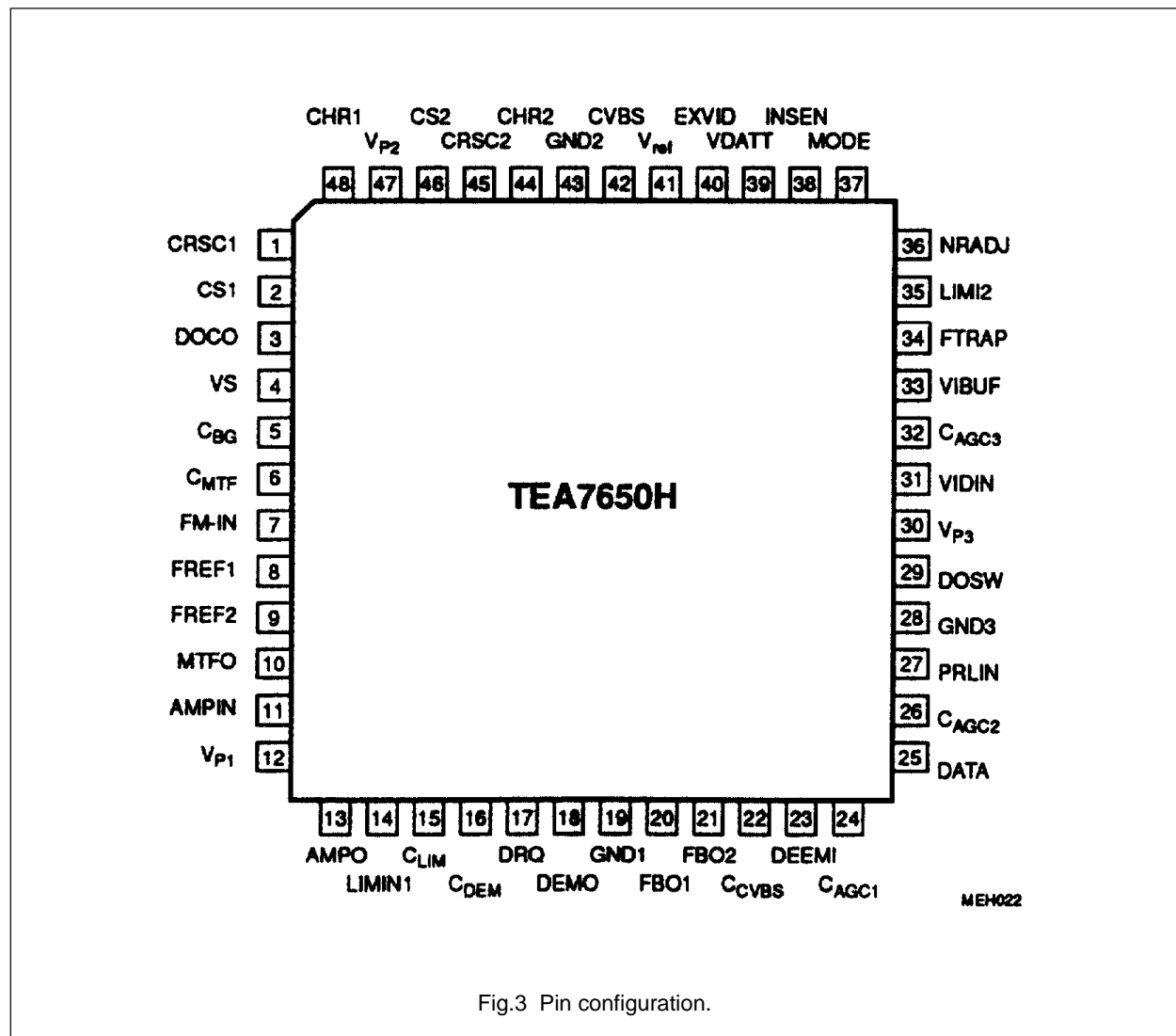

Fig.3 Pin configuration.

Video signal processor for CD-video/laser vision

TEA7650H

FUNCTIONAL DESCRIPTION

Figures 1, 2 show the block diagram of the Video Signal Processor (VSP) including the peripheral circuitry for the video signal processing. The pulse-width modulated FM signal from the preamplifier is fed, via a DC blocking capacitor, into the IC (pin 7) at the input to the Modulation Transfer Function (MTF) circuit which corrects for the characteristic of the optical reading system.

MTF correction

Due to the finite diameter of the laser beam spot and the tangential velocity of the track of pits on the disk, the MTF of the optical system acts like a radius-dependent low-pass filter for the FM input signal. Although the video signal can be recovered without correction, the ratio of the amplitudes of the chrominance and luminance signals would not then be the same at the most inner and the most outer part of the disk. This influence of the disk radius is automatically corrected by the Video Signal Processor. The principle of correction is to use the deviation of the demodulated burst signal to generate an error voltage in order to control the frequency selective MTF circuit. The burst measurement operates as follows: A burst-key generator is triggered by the line synchronization pulse (CS1) to generate a burst-key pulse which activates the burst gate and rectifier stage. The signal at the rectifier output (pin 6) is used to control the amplification of the MTF circuit.

The carrier frequency in the PAL standard is different to that in the NTSC standard, therefore two separate resonant circuits are required on pins 8 and 9. They are selected by the PAL/NTSC system selector (pin 37).

The MTF-corrected FM signal at pin 10 is amplified (+8 dB) and fed, via the external filter which removes the audio frequency components from the signal, into the demodulator at pin 14.

Demodulation

The FM signal is first fed into a limiter circuit (pin 14) with automatic slicing level control to suppress the main carrier in the demodulated signal. The demodulator has two outputs. The first (internal) clamps the demodulated video signal on peak-sync by controlling the transconductance of the demodulator. The FM signal can now be demodulated during disk start-up, thereby facilitating fast run-in. The second output signal from the demodulator (pin 18) is passed through an external 5 MHz low-pass filter to extract the CVBS signal. The CVBS signal is then fed into the de-emphasis network to compensate for the pre-emphasis of the video signal recorded on the disk.

De-emphasis

The de-emphasis circuit consists of an internal inverting amplifier and an external RC feedback network. Since the pre-emphasis on the disk in the PAL standard is different from that in the NTSC standard, the time constants are switchable. When PAL is selected, the first arm of the feedback network is active, otherwise both operate in parallel. The de-emphasized video signal is fed into an AGC stage (pin 20) where it is clamped on its black level and amplitude-controlled to a constant level. The signal is then fed into the data slicer and the drop out switch.

Data slicer

Coded signals on the video disk are extracted by the data slicer (output pin 25) when the Data Request input is activated (pin 17).

Drop out compensation

The drop out detector (DOD) in the IC is triggered by every positive or negative transition of the FM signal. A drop out is detected when the half-cycle period is outside the limits. Protection against a drop out is achieved by use of a video signal delayed by one line. The signal at the output of the drop out switch is fed out of the IC via a buffer (pin 29) and then through a delaying device (CCD) before being fed back into the IC (pin 27). The delayed video signal appears at the input of an AGC circuit to compensate for gain tolerances of the delay line and avoids the need for an external adjustment. When a drop out is detected, the drop out detector activates the video switch so that the lost information of the line is substituted by the information of the preceding line.

The drop out pulse is also present at pin 3 and can be used for different purposes. This pin can also act as an input to control the drop out switch by an external signal for test purposes.

Time error compensation

In a videodisc player timing errors are caused by deviations of the rotational speed of the motor, imperfections in the disk and unavoidable tolerances in the centering of the disk on the turntable. Track eccentricity is the main cause of timing errors.

To minimize timing errors, it is necessary in the first place to keep the rotational speed of the disk as constant as possible. Referring back to the output of the switch in Fig.1-2, the video signal is also fed into a sync separator and a chrominance separator with its external resonant circuits tuned to the chrominance subcarrier

Video signal processor for CD-video/laser vision

TEA7650H

frequency. The phase of the line synchronization pulses (CS1, pin 2) can be used to control the speed of the turntable motor.

However, with this method it is not possible to obtain an acceptable reduction of timing errors for frequencies of 25 Hz and above. To reduce errors, use is made of an external Electronic Time Base Corrector (ETBC) between pins 27 and 31 which functions as a variable delay line driven by an error signal.

This error signal can be extracted from the output signal CS1 (pin 2), CHR1 (pin 48), CS2 (pin 46) and CHR2 (pin 44).

Since the line sync pulses (CS1) are not suitable to achieve an accurate enough measurement of time difference, use is made of the 3.58 MHz burst signal derived from the chrominance signal CHR1. If the same zero crossing of the burst signal is used in every line, the actual time can be measured with sufficient accuracy.

The CVBS signal leaving the ETBC might still have small timing errors due to residual control error. A second (feedback) loop is therefore required. The CVBS signal is fed into an AGC circuit (pin 31) that compensates for gain tolerances in the ETBC. As in the first loop, the line synchronization pulses (CS2) and the chrominance signal (CHR2) are derived from the CVBS signal by using second sync and chrominance separators. The error signal obtained by comparison in this feedback loop is added to the error signal obtained in the first loop.

Using the burst signal for accurate measurements is a problem in the PAL format due to its alternating phase. A special 3.75 MHz (240 fh) burst has therefore been added to the video signal recorded on the PAL disk. This burst is inserted on the top level of the line sync pulses.

In dual standard applications, the resonant circuits of the chrominance separators (pins 1 and 45) should be tuned to 3.67 MHz to ensure good separation of the special burst or the chrominance subcarrier.

When the timebase-corrected CVBS signal has by-passed the second sync and chrominance separators, it reaches the special burst suppressor which removes the special burst. The signal is then fed into the noise reduction circuit.

Noise reduction

A noise reduction circuit can be used to improve the apparent picture quality of a noisy signal. It operates as follows: First the timebase corrected CVBS signal is buffered (pin 33) and then fed into an external network which removes the chrominance subcarrier and all

low-frequency components. It is then fed into a limiter (pin 35) which ensures that only small amplitudes (mainly noise) are removed from the main signal.

The chrominance subcarrier trap is switched to either the PAL subcarrier frequency (4.43 MHz) or the NTSC subcarrier (3.58 MHz) by the PAL/NTSC system selector (pin 37) using the additional small capacitor at pin 34. An external resistor at pin 36 is included so that manufacturers can select their preferred level of noise reduction, or none at all, by grounding the pin.

Picture insertion

The CVBS signal containing the information to be displayed is applied to pin 40. A clamp circuit ensures that the black level of this signal is the same as that of the main signal. Both signals are applied to the insertion switch.

When, for example, a character is to be displayed the 6 dB attenuation (pin 39) is first activated to generate a reduced contrast background area around the character (with respect to the black level so that the original picture is still visible). Next, the insertion switch (pin 38) is activated and the character appears at the output. By switching back to the original picture, the procedure operates in the reverse sequence.

Other examples of the picture insertion facility are displaying a background picture during start-up of the video disk player or the use of picture-in-picture.

A buffer is provided at the CVBS output (pin 42) which delivers a CVBS signal clamped to black level and controlled to a peak-to-peak amplitude of 1 V.

Reference voltage

A reference voltage of 1.6 V is provided by a bandgap circuit. Internally, all control circuits are supplied with this reference voltage. Externally, it can be used for various purposes.

Video signal processor for CD-video/laser vision

TEA7650H

LIMITING VALUES

Limiting values in accordance with the Absolute Maximum System (IEC 134).

SYMBOL	PARAMETER	MIN.	MAX.	UNIT
V _{P1}	supply voltage 1 (pin 12)	0	6	V
V _{P2}	supply voltage 2 (pin 47)	0	6	V
V _{P3}	supply voltage 3 (pin 30)	0	6	V
V _n	voltage on all pins except ground pins	0	V _P	V
P _{tot}	total power dissipation	0	360	mW
T _{stg}	storage temperature range	-25	+150	°C
T _{amb}	operating ambient temperature range	0	+70	°C
V _{ESD}	electrostatic handling ⁽¹⁾ for all pins	±400	–	V

Note

1. Equivalent to discharging a 200 pF capacitor through a 0 Ω series resistor.

THERMAL RESISTANCE

SYMBOL	PARAMETER	MIN.	MAX.	UNIT
R _{th j-a}	from junction to ambient in free air	–	92	K/W

Video signal processor for CD-video/laser vision

TEA7650H

CHARACTERISTICS

$V_{P1} = V_{P2} = V_{P3} = 5 \text{ V}$, $T_{\text{amb}} = 25 \text{ }^\circ\text{C}$, measurements taken in Fig.1-2 ; unless otherwise specified.

Voltages referred to	GND1 (pin 19):	V_{P1} and voltage at pins 6 to 15, 18
	GND2 (pin 43):	V_{P2} and voltage at pins 1 to 4, 16, 37, 44 to 48
	GND3 (pin 28):	V_{P3} and voltage at pins 5, 17, 20 to 36, 38 to 42

SYMBOL	PARAMETER	CONDITIONS	MIN.	TYP.	MAX.	UNIT
V_{P1}	supply voltage 1 (pin 12)		4.5	5	5.5	V
V_{P2}	supply voltage 2 (pin 47)		4.5	5	5.5	V
V_{P3}	supply voltage 3 (pin 30)		4.5	5	5.5	V
$I_{12+30+47}$	total supply current		–	–	65	mA
Standard select input (pin 37)						
V_{IL}	input voltage for standard PAL (LOW)		0	–	1	V
V_{IH}	input voltage for standard NTSC (HIGH), alternative measure for standard NTSC	pin connected pin open-circuit	3 –	– –	V_{P2} –	V
I_{IL}	input current (LOW)	$V_{37} = 1 \text{ V}$	–	–	–100	μA
I_{IH}	input current (HIGH)	$V_{37} = 4 \text{ V}$	–	–	20	μA
Modulation transfer function MTF (referred to GND1, pin 19)						
$V_{i(p-p)}$	FM input signal at pin 7 (peak-to-peak value) for proper MTF correction		50 50	– –	300 200	mV mV
Z_7	input impedance		–	5	–	k Ω
$I_{(p-p)}$	MTF control signal output current for storage of the burst amplitude at pin 5 (peak-to-peak value)		–	200	–	μA
I_6	burst amplitude integrator, charging current (pin 6)		–	± 50	–	μA
g	conductance $g = dI_6 / dV_5$		–	–1	–	mS
$V_{o(p-p)}$	MTF frequency selection (pins 8 and 9) output signal	pin 8 active for PAL; pin 9 active for NTSC	–	$V_7(p-p)$	–	mV
Z	output impedance		–	–	10	Ω
$I_{o(p-p)}$	output current		–	–	4.5	mA
$V_{o(p-p)}$	MTF output signal (pin 10)		–	–	300	mV
Z_{10}	MTF output impedance		–	–	100	Ω
G_v	signal gain	$G_v = V_{10} / V_7$				
G_o	$G_v = G_o + 20 \log G_r (V_6)$		–	0	–	dB
G_r	minimum gain	$V_6 = 0$	–	0	–	dB
	maximum gain	$V_6 = 2.6 \text{ V}$	–	300 Ω /R8	–	
	maximum gain	$V_6 = 2.6 \text{ V}$	–	300 Ω /R9	–	
B	bandwidth	–3 dB; $G_r = 0$	15	–	–	MHz
α_{2H}	second harmonic suppression	$f = 8 \text{ MHz}$	40	–	–	dB

Video signal processor for CD-video/laser vision

TEA7650H

SYMBOL	PARAMETER	CONDITIONS	MIN.	TYP.	MAX.	UNIT
MTF following amplifier (pins 11 and 13)						
$V_{i(p-p)}$	FM input signal at pin 11 (peak-to-peak value)		–	–	300	mV
Z_{11}	input impedance		10	–	–	k Ω
R_E	internal emitter resistor to ground		–	1.8	–	k Ω
Z_{13}	output impedance (pin 13)		–	–	50	Ω
$I_{o(p-p)}$	output current at pin 13 (peak-to-peak value)		–	–	1	mA
G_v	voltage gain (pins 13-11)		–	8	–	dB
B	bandwidth (pin 13)	–3 dB	15	–	–	MHz
α_{2H}	second harmonic suppression		40	–	–	dB
Limiting amplifier for demodulator						
$V_{i(p-p)}$	input signal for proper demodulation at pin 14 (peak-to-peak value)		0.1	–	1	V
Z_{14}	input impedance		10	–	–	k Ω
$I_{(p-p)}$	charging current of 2nd harmonic control at pin 15 (peak-to-peak value)		–	200	–	μ A
FM demodulator with pulswidth-modulated current output ($f = 2 f_{in}$). Referred to GND1, pin 19						
$I_{(p-p)}$	output current pulse at pin 18 (peak-to-peak value)		–	–3.2	–	mA
I_{18}	mean (average) DC current	for top sync	–	–1.75	–	mA
Z_{18}	output impedance		30	–	–	k Ω
V_{18}	DC output voltage range		0	–	2	V
S	transconductance	at PAL at NTSC	–	–210 –185	–	μ A/MHz μ A/MHz
N	static non-linearity		–	–	10	%
B	bandwidth	± 1 dB	5	–	–	MHz
α	main carrier suppression	$V_{14(p-p)} = 100$ mV	35	–	–	dB
$I_{(p-p)}$	charging current at pin 16 (amplitude storage for top sync, peak-to-peak value)		–	26	–	μ A
De-emphasis amplifier (output pin 21 only for NTSC active). Referred to GND3, pin 28						
Z_{23}	input impedance (pin 23)		10	–	–	k Ω
I_{23}	DC input current		–	–	2	μ A
$I_{(p-p)}$	charging current for black clamping capacitor at pin 22 (peak-to-peak value)		–	3	–	μ A
$R_{20, 21}$	output impedance (pins 20 and 21)		–	–	100	Ω
$V_{20, 21}$	DC output voltage (black level)		–	2.2	–	V
BW_g	gain bandwidth product		40	–	–	MHz
$I_{24(p-p)}$	charging current for AGC capacitor at pin 24 (peak-to-peak current)		–	11	–	μ A

Video signal processor for CD-video/laser vision

TEA7650H

SYMBOL	PARAMETER	CONDITIONS	MIN.	TYP.	MAX.	UNIT
Composite sync output CS1 (pin 2; referred to GND2, pin 43)						
V_{oH}	sync output voltage (active HIGH)	$I_2 = -0.5 \text{ mA}$	4	–	–	V
V_{oL}	sync output voltage (LOW)	$I_2 = 0.5 \text{ mA}$	–	–	0.4	V
t_d	delay of positive going sync edge		–	–	300	ns
Δt_d	jitter of positive going sync edge		–	–	40	ns
t_r, t_f	rise and fall time	$C_L = 22 \text{ pF}$	–	–	200	ns
Vertical sync output (VS) , open collector output with 500 Ω internal series resistor, referred to GND2, pin 43						
V_4	sync output voltage active LOW (pin 4)	$I_4 = -0.5 \text{ mA}$	–	–	0,7	V
t_d	delay time		–	18	–	μs
t_e	elongation time		–	70	–	μs
Drop out processing. (referred to GND3, pin 28)						
f_i	frequency range for no drop out recognition					
f_1	minimum value at PAL		–	5.6	–	MHz
f_2	maximum value at PAL		–	9.7	–	MHz
f_1	minimum value at NTSC		–	6.97	–	MHz
f_2	maximum value at NTSC		–	11.1	–	MHz
t_d	delay time on negative going edge for an abrupt drop out with $f < 0.5 f_1$ or $f > 1.5 f_2$		–	–	250	ns
t_e	drop out elongation time	$C3 = 47 \text{ pF};$ $R3 = 100 \text{ k}\Omega$	–	3.5	–	μs
V_3	output voltage during drop out	internal $R_S = 500 \Omega;$ $I_3 = -0.5 \text{ mA}$	–	–	0.7	V
$V_{3 \text{ thr}}$	threshold voltage of drop out switch		–	2	–	V
$V_{3 \text{ DO}}$	input voltage for forced drop out switching		0		0.7	V
$V_{i \text{ (p-p)}}$	delayed video input signal at pin 27 (peak-to-peak value)	$R_G \leq 1 \text{ k}\Omega$	–	700	–	mV
V_{27}	DC input voltage (black level)		–	2.2	–	V
Z_{27}	input impedance		10	–	–	$\text{k}\Omega$
$I_{\text{(p-p)}}$	charging current for coupling capacitor at pin 27 (peak-to-peak value)		–	3	–	μA
$I_{\text{(p-p)}}$	charging current for AGC of the delayed signal at pin 26 (peak-to-peak value)		–	11	–	μA

Video signal processor for CD-video/laser vision

TEA7650H

SYMBOL	PARAMETER	CONDITIONS	MIN.	TYP.	MAX.	UNIT	
Chrominance output for purpose of ETBC , with $R_L = 5 \text{ k}\Omega$ (pin 48) and nominal input signal. Resonant circuit at pin 1 tuned to 4.43 MHz for PAL (3.58 MHz for NTSC). Referred to GND2, pin 43. See previous comment to characteristics.							
$V_{o(p-p)}$	burst amplitude (peak-to-peak value) at pin 48	PAL; $f = 4.43 \text{ MHz}$	–	760	–	mV	
		NTSC; $f = 3.58 \text{ MHz}$	–	725	–	mV	
Z_{48}	output impedance		–	–	250	Ω	
$I_{o(p-p)}$	output current (peak-to-peak value)		–	–	700	μA	
α_{CR}	crosstalk attenuation from pin 44		32	–	–	dB	
R_1	output impedance for resonant circuit		–	1.4	–	$\text{k}\Omega$	
Electronic time base control ETBC and CCD delay (external). Referred to GND3, pin 28.							
$V_{o(p-p)}$	CVBS output signal of emitter output at pin 29 (peak-to-peak value) burst amplitude in signal	$V_{20(p-p)} = 0.5 \text{ V} \pm 3 \text{ dB}$ (peak-to-peak value)	–	850	–	mV	
		for PAL	–	230	–	mV	
		for NTSC	–	219	–	mV	
V_{29}	DC output voltage (black level)		–	1.85	–	V	
Z_{29}	output impedance		–	$-V_t / I_{29}$	–	Ω	
I_{29}	output current (source)		–	–	–3	mA	
S/N	signal-to-noise ratio from pin 7 to pin 29	5 MHz unweighted	50	–	–	dB	
$\Delta V_{o(p-p)}$	difference of CVBS amplitude (peak-to-peak value) at pin 29 referred to 0 dB level at pin 29 referred to $\pm 4 \text{ dB}$ level	switching from main to delayed signal; $V_{27(p-p)} = 0.7 \text{ V}$ 0 dB	–	–	–	± 2	%
		$\pm 4 \text{ dB}$	–	–	–	± 6	%
		$f = 2 \text{ MHz}$	35	–	–	–	dB
α_{CR}	crosstalk attenuation		–	–	–	dB	
ΔV_{29}	offset voltage after switching		–	–	10	mV	
ΔV_S	spike amplitude at switching (pin 29)	$t_S > 50 \text{ ns}$	–	–	15	mV	
Chrominance and luminance amplifier (referred to GND3, pin 28).							
$V_{i(p-p)}$	delayed CVBS input signal (pin 31)	$R_G \leq 1 \text{ k}\Omega$	–	600	–	mV	
V_{31}	DC input voltage (black level)		–	2.2	–	V	
Z_{31}	input impedance		10	–	–	$\text{k}\Omega$	
$I_{(p-p)}$	charging current for coupling capacitor at pin 31 (peak-to-peak value)		–	3	–	μA	
$I_{(p-p)}$	charging current for AGC at pin 32 (peak-to-peak value)		–	11	–	μA	

Video signal processor for CD-video/laser vision

TEA7650H

SYMBOL	PARAMETER	CONDITIONS	MIN.	TYP.	MAX.	UNIT
Chrominance output for purpose of ETBC , with $R_L = 5 \text{ k}\Omega$ (pin 44) and nominal input signal. Resonant circuit at pin 45 tuned to 4.43 MHz for PAL (3.58 MHz for NTSC). Referred to GND2, pin 43. See previous comment to characteristics.						
$V_{o(p-p)}$	burst amplitude (peak-to-peak value) at pins 44 for PAL for NTSC	$f = 4.43 \text{ MHz}$ $f = 3.58 \text{ MHz}$	–	760 725	–	mV mV
Z_{44}	output impedance		–	–	250	Ω
$I_{o(p-p)}$	output current (peak-to-peak value)		–	–	700	μA
α_{CR}	crosstalk attenuation from pin 48		32	–	–	dB
R_{45}	output impedance for resonant circuit		–	1.4	–	$\text{k}\Omega$
Luminance noise reduction (referred to GND3, pin 28)						
$V_{(p-p)}$	output signal at pin 33 (peak-to-peak value)	$V_{i(p-p)} = 0.6 \text{ V} \pm 3 \text{ dB}$ at pin 31	–	1	–	V
V_{33}	DC output voltage (black level)		–	2.2	–	V
I_E	internal emitter current to ground of emitter follower		–	1	–	mA
Z_{33}	output impedance		–	–	100	Ω
$I_{o(p-p)}$	AC output current at pin 33 (peak-to-peak value)		–	–	1.5	mA
$I_{(p-p)}$	chroma trap switch, active for NTSC input current (peak-to-peak value)		–	–	350	μA
Z_{34}	input impedance (pin 34)		–	–	50	Ω
$V_{i(p-p)}$	limiter amplifier input signal at pin 35 (peak-to-peak value) input signal for start of limiting		– 0	1 –	– 100	V mV
Z_{35}	input impedance		–	2	–	$\text{k}\Omega$
V_{36}	voltage range or limiter control (pin 36) voltage for control-off		0.1 –	– 0	1.5 –	V V
I_{36}	DC output current		–	–100	–	μA
Main CVBS output (referred to GND3, pin 28).						
$V_{o(p-p)}$	CVBS output signal of emitter output at pin 42 (peak-to-peak value)	$V_{i(p-p)} = 0.6 \text{ V} \pm 0 \text{ dB}$ at pin 31	–	1	–	V
$\Delta V_{o(p-p)}$	residual variation of output voltage at pin 42 (peak-to-peak value)	$V_{i(p-p)} = 0.6 \text{ V} \pm 3 \text{ dB}$ at pin 31	–	–	± 3	%
V_{42}	DC output voltage (black level)		–	2.2	–	V
I_E	internal emitter current to ground of emitter follower		–	300	–	μA
Z_{42}	output impedance		–	–	100	Ω
I_o	output source current		–	–	–5	mA
B	video bandwidth	–3 dB	5			MHz
S/N	signal-to-noise ratio from pin 31 to pin 42	5 MHz unweighted	60	–	–	dB

Video signal processor for CD-video/laser vision

TEA7650H

SYMBOL	PARAMETER	CONDITIONS	MIN.	TYP.	MAX.	UNIT
α_{CR}	crosstalk attenuation between main and inserted signal	$f = 5 \text{ MHz}$	45	–	–	dB
α_{burst}	differences at output due to switching from main to inserted signal (pin 42) suppression of special burst		35	–	–	dB
ΔV_{42}	offset voltage after switching		–	–	50	mV
ΔV_S	spike amplitude at switching	$t_S > 50 \text{ ns}$	–	–	20	mV
ΔV_{VID}	video attenuation for internal signal	$V_{39} = \text{HIGH}$	–	6	–	dB
External video insertion input and switching control						
V_i (p-p)	input signal at pin 40 (peak-to-peak value)	$R_G \leq 1 \text{ k}\Omega$	–	1	–	V
V_{40}	DC voltage (black level)		–	2.9	–	V
G_V	voltage gain (pins 42-40)		–	0	–	dB
Z_{40}	input impedance		10	–	–	k Ω
I (p-p)	charging current at pin 40 (peak-to-peak value)		–	3	–	μA
B	video bandwidth	–3 dB	8	–	–	MHz
V_{38}	voltage for insertion-on (HIGH) voltage for insertion-off (LOW)		3 0	– –	V_P 1	V V
I_{38}	input current (HIGH) input current (LOW)	$V_{38} = 4 \text{ V}$ $V_{38} = 1 \text{ V}$	– –	– –	2 –10	μA μA
t_d	switchover delay time		–	–	50	ns
V_{39}	voltage for video attenuation-on (HIGH) voltage for video attenuation-off (LOW)	–6 dB video 0 dB video	3 0	– –	V_P 1	V V
I_{39}	input current (HIGH)	$V_{39} = 4 \text{ V}$	–	–	2	μA
I_{39}	input current (LOW)	$V_{39} = 1 \text{ V}$	–	–	–10	μA
t_d	switchover delay time		–	–	100	ns
Data output and data request input (pins 25 and 17)						
V_{25}	output voltage HIGH-level (pin 25) output voltage LOW-level	$I_{25} = -0.5 \text{ mA}$ $I_{25} = 0.5 \text{ mA}$	3.5 –	– –	– 0.8	V V
t_p	duty factor (t_p / T)		–	50	–	%
t_r and t_f	rise and fall time	$C_L = 22 \text{ pF}$	–	–	150	ns
t_d	delay time		–	–	200	ns
V_{17}	voltage for data request-on (HIGH) at pin 17		3	–	V_P	V
	voltage for data request-off (LOW)		0	–	1	V
I_{17}	input current (HIGH) input current (LOW)	$V_{17} = 4 \text{ V}$ $V_{17} = 1 \text{ V}$	– –	– –	20 –100	μA μA
t_d	data delay time		–	–	200	ns

Video signal processor for CD-video/laser vision

TEA7650H

SYMBOL	PARAMETER	CONDITIONS	MIN.	TYP.	MAX.	UNIT
Composite sync output CS2 (referred to GND2, pin 43)						
V ₄₆	sync output voltage (active HIGH)	I ₄₆ = -0.5 mA	4	–	–	V
	sync output voltage at pin 46 (LOW)	I ₄₆ = 0.5 mA	–	–	0.4	V
t _d	delay of positive going sync edge		–	–	300	ns
Δt _d	jitter of positive going sync edge		–	–	40	ns
t _r	rise time	C _{L 46} = 22 pF	–	–	150	ns
t _f	fall time	C _{L 46} = 22 pF	–	–	200	ns
Reference output voltage (referred to GND3, pin 28)						
V _{ref}	reference output voltage (pin 41)		–	1.6	–	V
R ₄₁	output resistance		–	–	5	kΩ
I _{ref}	output current (used for CCD reference)		–	–	±10	μA
dV ₄₁ /dV _P	supply voltage dependence		–	–	–20	dB
dV ₄₁	dependence of junction temperature	T _j = 20 to 120 °C	–	–	±30	mV

Video signal processor for CD-video/laser vision

TEA7650H

APPLICATION INFORMATION

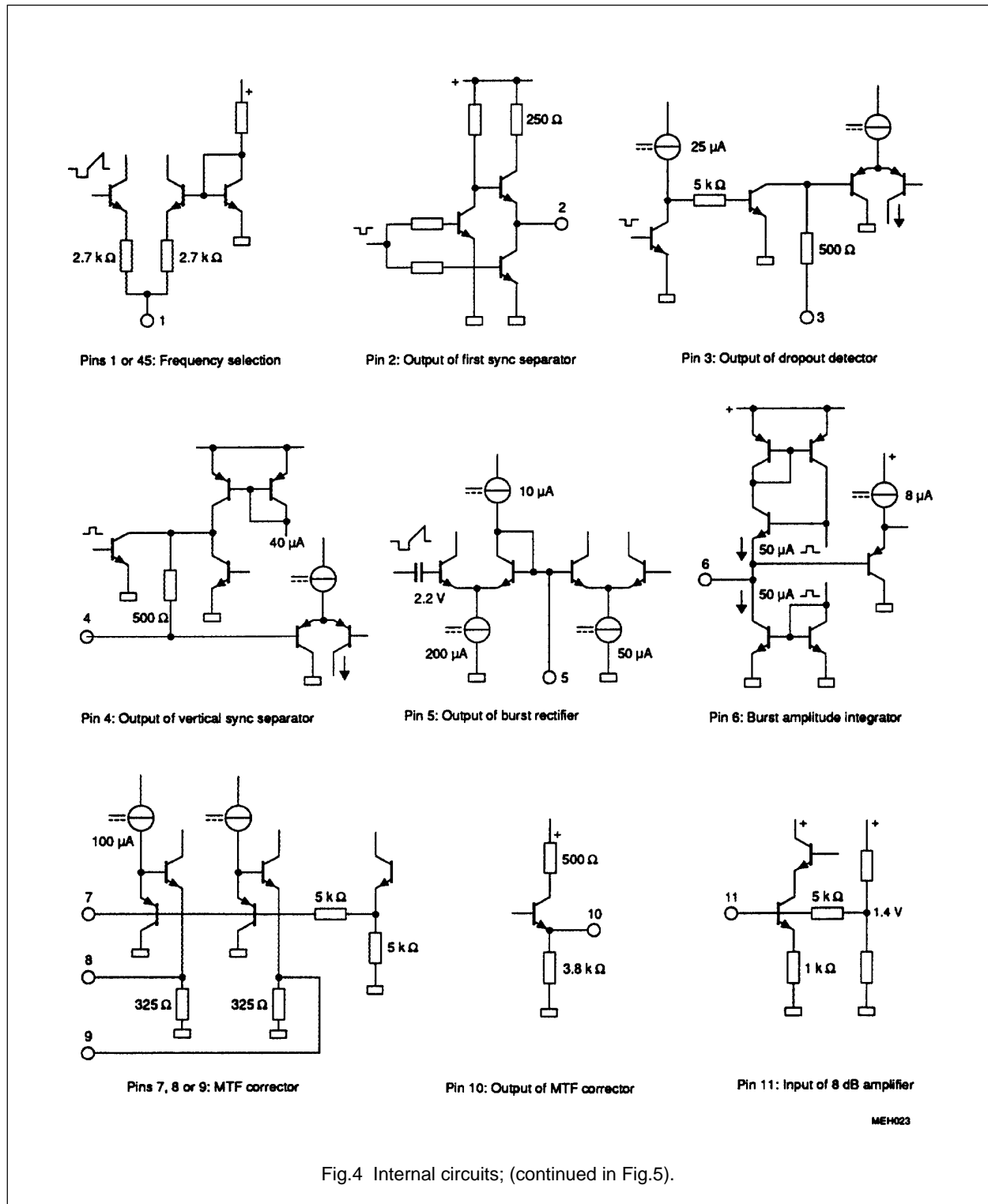

Fig.4 Internal circuits; (continued in Fig.5).

Video signal processor for CD-video/laser vision

TEA7650H

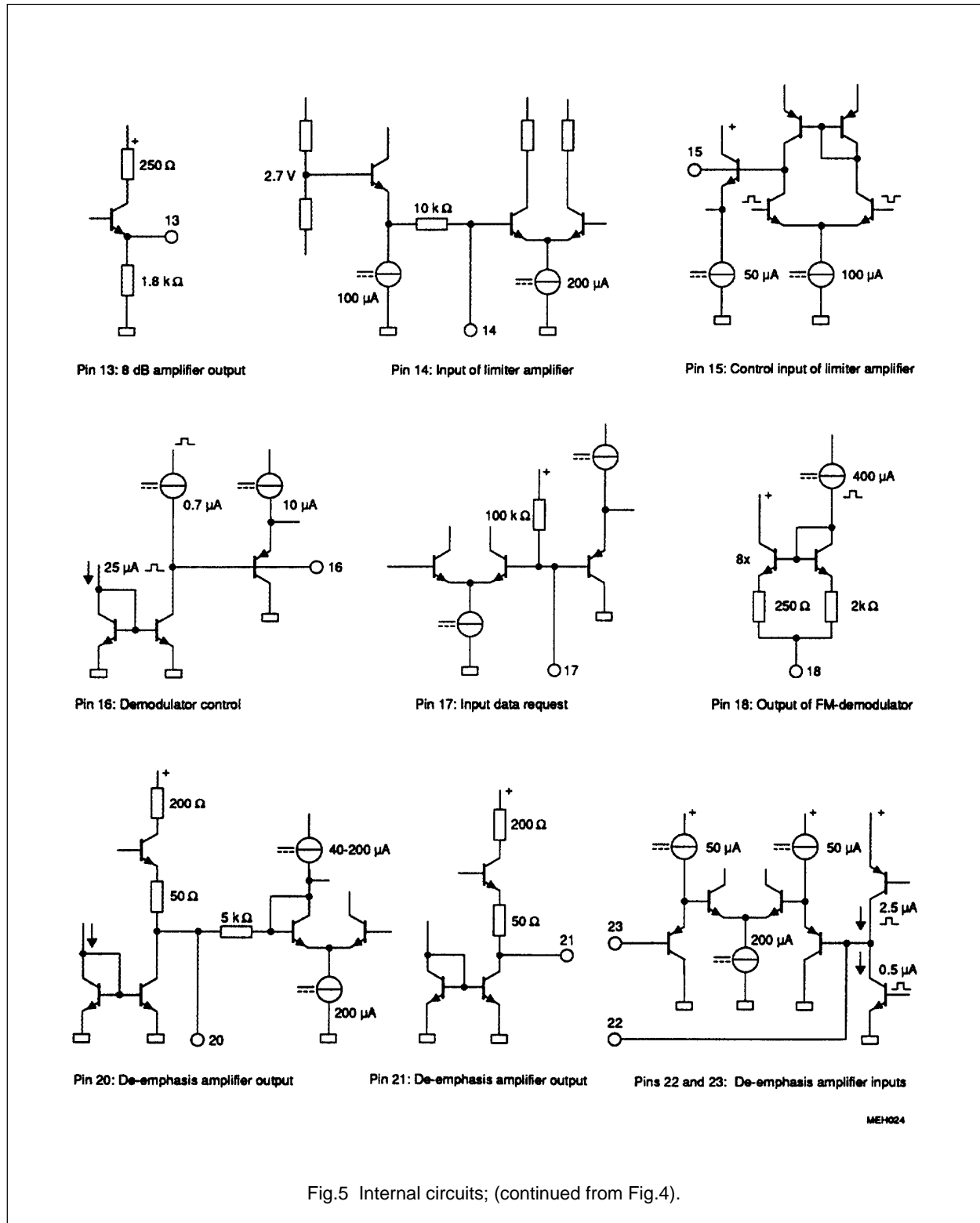

Fig.5 Internal circuits; (continued from Fig.4).

Video signal processor for CD-video/laser vision

TEA7650H

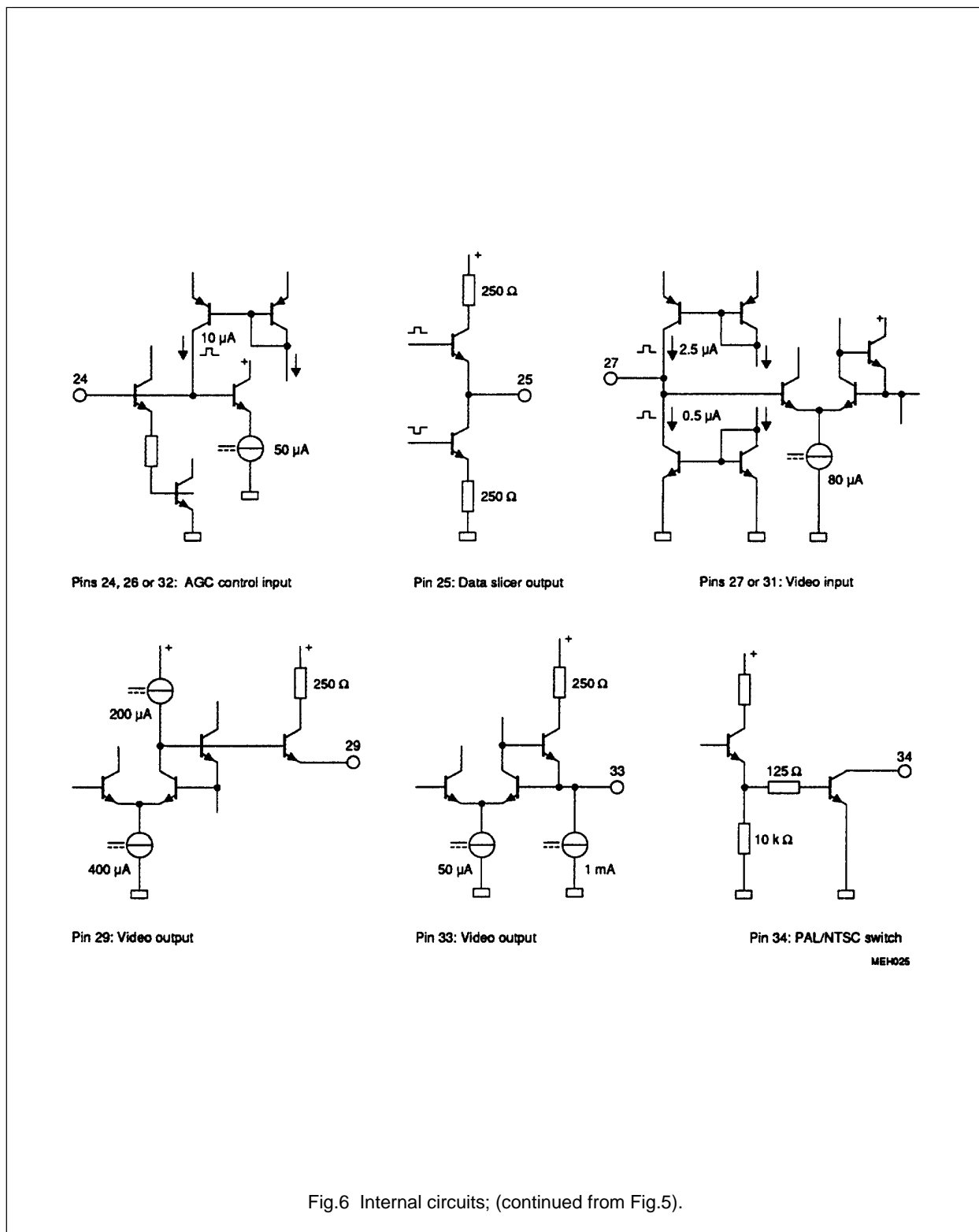

Fig.6 Internal circuits; (continued from Fig.5).

Video signal processor for CD-video/laser vision

TEA7650H

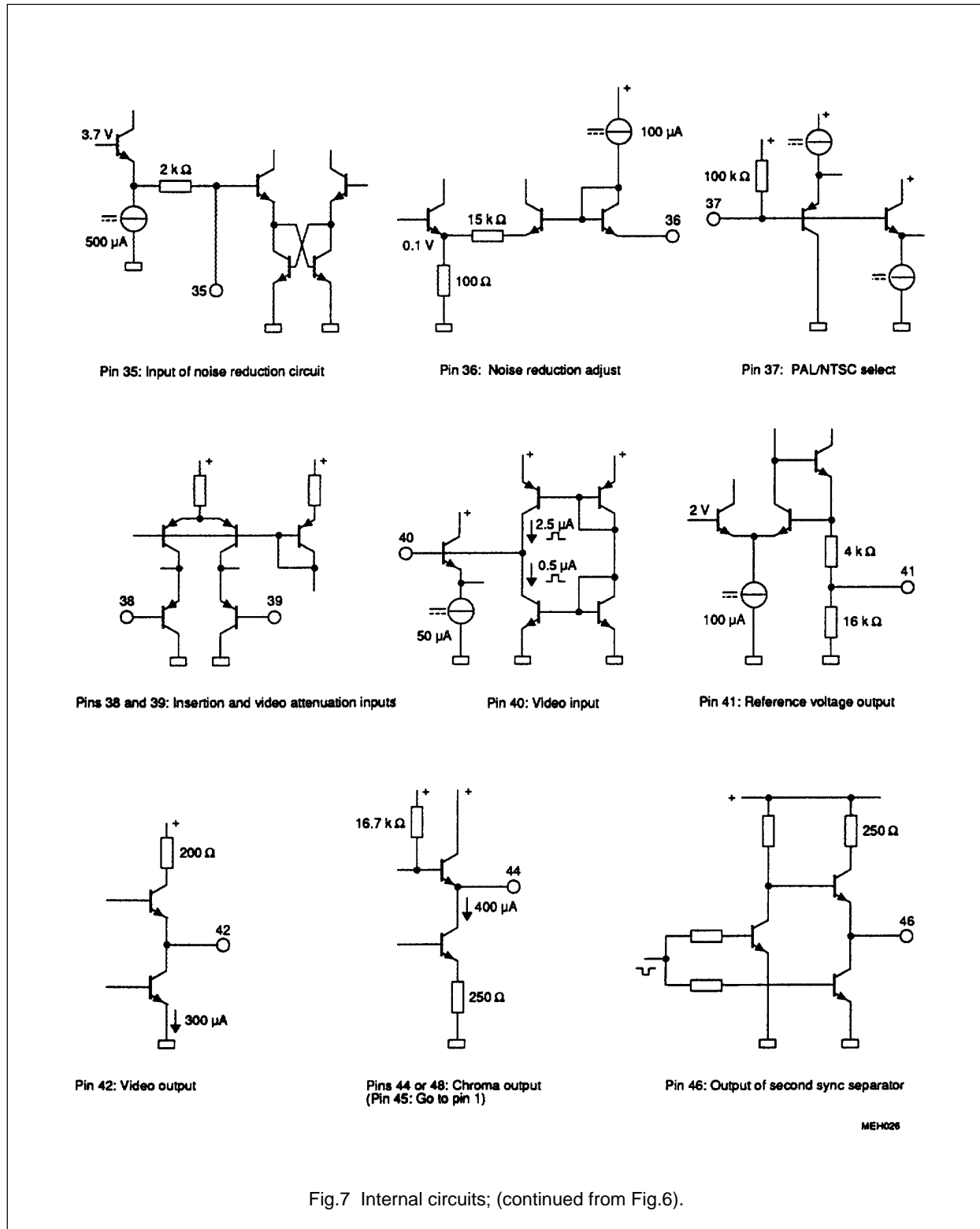

Fig.7 Internal circuits; (continued from Fig.6).

Video signal processor for CD-video/laser vision

TEA7650H

PACKAGE OUTLINE

QFP48: plastic quad flat package; 48 leads (lead length 2.5 mm); body 10 x 10 x 1.75 mm

SOT196-1

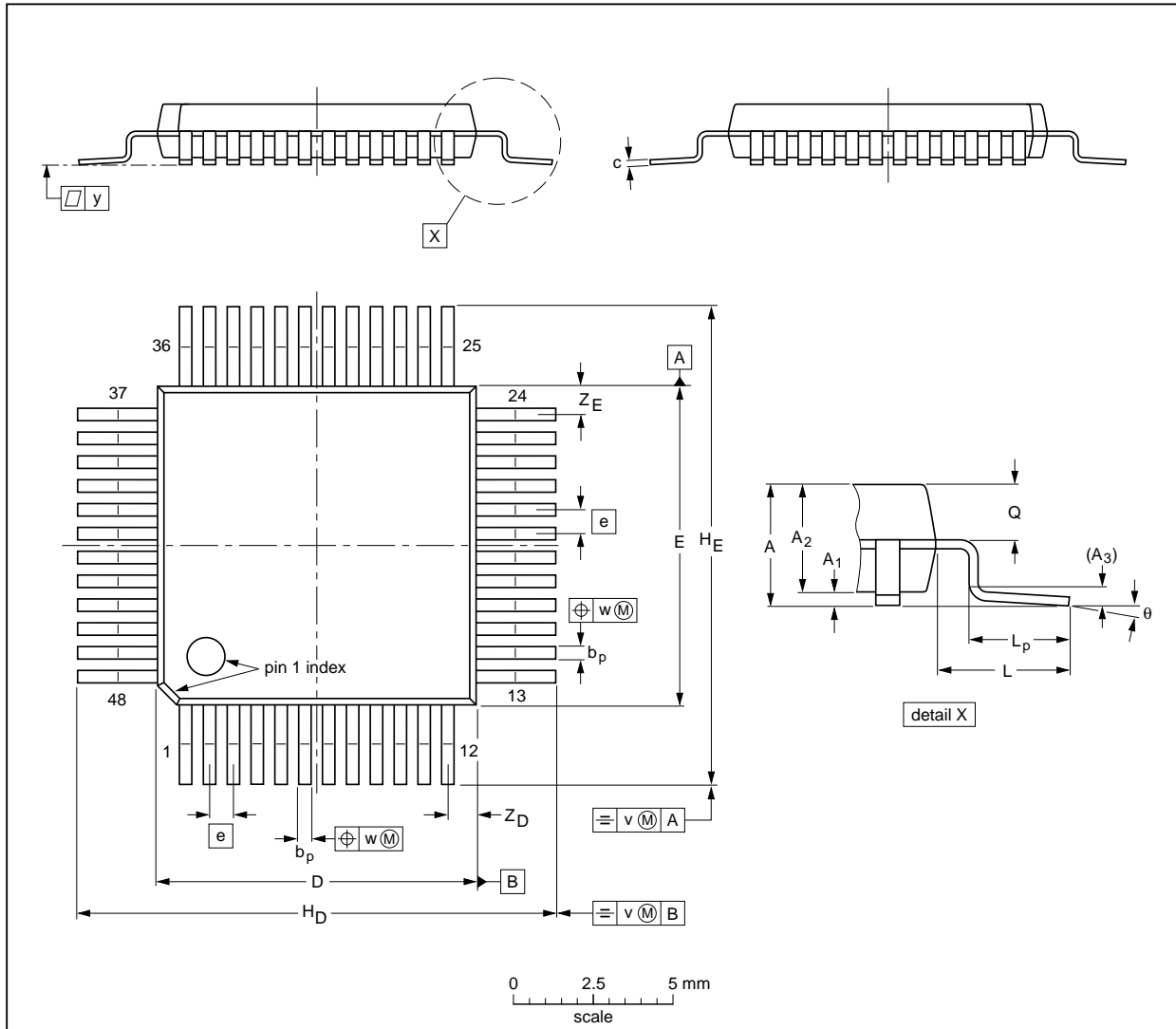

DIMENSIONS (mm are the original dimensions)

UNIT	A max.	A ₁	A ₂	A ₃	b _p	c	D ⁽¹⁾	E ⁽¹⁾	e	H _D	H _E	L	L _p	Q	v	w	y	Z _D ⁽¹⁾	Z _E ⁽¹⁾	θ
mm	2.20	0.3 0.1	1.85 1.65	0.25	0.42 0.28	0.25 0.14	10.1 9.9	10.1 9.9	0.75	15.5 14.5	15.5 14.5	2.5	2.4 1.6	1.05 0.75	0.3	0.15	0.1	1.05 0.70	1.05 0.70	7° 0°

Note

1. Plastic or metal protrusions of 0.25 mm maximum per side are not included.

OUTLINE VERSION	REFERENCES				EUROPEAN PROJECTION	ISSUE DATE
	IEC	JEDEC	EIAJ			
SOT196-1						92-11-17 95-02-04

Video signal processor for CD-video/laser vision

TEA7650H

SOLDERING

Introduction

There is no soldering method that is ideal for all IC packages. Wave soldering is often preferred when through-hole and surface mounted components are mixed on one printed-circuit board. However, wave soldering is not always suitable for surface mounted ICs, or for printed-circuits with high population densities. In these situations reflow soldering is often used.

This text gives a very brief insight to a complex technology. A more in-depth account of soldering ICs can be found in our "IC Package Databook" (order code 9398 652 90011).

Reflow soldering

Reflow soldering techniques are suitable for all QFP packages.

The choice of heating method may be influenced by larger plastic QFP packages (44 leads, or more). If infrared or vapour phase heating is used and the large packages are not absolutely dry (less than 0.1% moisture content by weight), vaporization of the small amount of moisture in them can cause cracking of the plastic body. For more information, refer to the Drypack chapter in our "Quality Reference Handbook" (order code 9397 750 00192).

Reflow soldering requires solder paste (a suspension of fine solder particles, flux and binding agent) to be applied to the printed-circuit board by screen printing, stencilling or pressure-syringe dispensing before package placement.

Several techniques exist for reflowing; for example, thermal conduction by heated belt. Dwell times vary between 50 and 300 seconds depending on heating method. Typical reflow temperatures range from 215 to 250 °C.

Preheating is necessary to dry the paste and evaporate the binding agent. Preheating duration: 45 minutes at 45 °C.

Wave soldering

Wave soldering is **not** recommended for QFP packages. This is because of the likelihood of solder bridging due to closely-spaced leads and the possibility of incomplete solder penetration in multi-lead devices.

If wave soldering cannot be avoided, the following conditions must be observed:

- **A double-wave (a turbulent wave with high upward pressure followed by a smooth laminar wave) soldering technique should be used.**
- **The footprint must be at an angle of 45° to the board direction and must incorporate solder thieves downstream and at the side corners.**

Even with these conditions, do not consider wave soldering the following packages: QFP52 (SOT379-1), QFP100 (SOT317-1), QFP100 (SOT317-2), QFP100 (SOT382-1) or QFP160 (SOT322-1).

During placement and before soldering, the package must be fixed with a droplet of adhesive. The adhesive can be applied by screen printing, pin transfer or syringe dispensing. The package can be soldered after the adhesive is cured.

Maximum permissible solder temperature is 260 °C, and maximum duration of package immersion in solder is 10 seconds, if cooled to less than 150 °C within 6 seconds. Typical dwell time is 4 seconds at 250 °C.

A mildly-activated flux will eliminate the need for removal of corrosive residues in most applications.

Repairing soldered joints

Fix the component by first soldering two diagonally-opposite end leads. Use only a low voltage soldering iron (less than 24 V) applied to the flat part of the lead. Contact time must be limited to 10 seconds at up to 300 °C. When using a dedicated tool, all other leads can be soldered in one operation within 2 to 5 seconds between 270 and 320 °C.

**Video signal processor for CD-video/laser
vision**

TEA7650H**DEFINITIONS**

Data sheet status	
Objective specification	This data sheet contains target or goal specifications for product development.
Preliminary specification	This data sheet contains preliminary data; supplementary data may be published later.
Product specification	This data sheet contains final product specifications.
Limiting values	
Limiting values given are in accordance with the Absolute Maximum Rating System (IEC 134). Stress above one or more of the limiting values may cause permanent damage to the device. These are stress ratings only and operation of the device at these or at any other conditions above those given in the Characteristics sections of the specification is not implied. Exposure to limiting values for extended periods may affect device reliability.	
Application information	
Where application information is given, it is advisory and does not form part of the specification.	

LIFE SUPPORT APPLICATIONS

These products are not designed for use in life support appliances, devices, or systems where malfunction of these products can reasonably be expected to result in personal injury. Philips customers using or selling these products for use in such applications do so at their own risk and agree to fully indemnify Philips for any damages resulting from such improper use or sale.