

DATA SHEET

TEA1118; TEA1118A Versatile cordless transmission circuit

Product specification
Supersedes data of 1996 Nov 26
File under Integrated Circuits, IC03

1997 Jul 14

Versatile cordless transmission circuit

TEA1118; TEA1118A

FEATURES

- Low DC line voltage; operates down to 1.6 V (excluding polarity guard)
- Voltage regulator with adjustable DC voltage
- Provides a supply for external circuits
- Symmetrical high impedance transmit inputs (62.5 k Ω) with large signals handling capabilities [up to 1 V (RMS value) with less than 2% THD]
- Receive amplifier for dynamic, magnetic or piezoelectric earpieces
- AGC line loss compensation for transmit and earpiece amplifiers
- DTMF input with confidence tone (TEA1118A only)
- MUTE input for pulse or DTMF dialling (TEA1118A only)
- Transmit mute function, also enabling the DTMF input (TEA1118A only).

APPLICATIONS

- Cordless telephone base stations
- Fax machines
- Answering machines.

QUICK REFERENCE DATA

$I_{line} = 15 \text{ mA}$; $V_{EE} = 0 \text{ V}$; $R_{SLPE} = 20 \text{ }\Omega$; AGC pin connected to V_{EE} ; $Z_{line} = 600 \text{ }\Omega$; $f = 1 \text{ kHz}$; $T_{amb} = 25 \text{ }^\circ\text{C}$; unless otherwise specified.

SYMBOL	PARAMETER	CONDITIONS	MIN.	TYP.	MAX.	UNIT
I_{line}	line current operating range	normal operation	11	–	140	mA
		with reduced performance	1	–	11	mA
V_{LN}	DC line voltage		3.35	3.65	3.95	V
I_{CC}	internal current consumption	$V_{CC} = 2.9 \text{ V}$	–	1.15	1.4	mA
V_{CC}	supply voltage for peripherals	$I_P = 0 \text{ mA}$	–	2.9	–	V
G_{vtrx}	typical voltage gain range					
	transmit amplifier (TEA1118A only)	$V_{TX} = 200 \text{ mV (RMS)}$	–	–	11.3	dB
	transmit amplifier (TEA1118 only)	$V_{TX} = 200 \text{ mV (RMS)}$	5.3	–	11.3	dB
	receive amplifier	$V_{IR} = 4 \text{ mV (RMS)}$	19	–	31	dB
ΔG_{vtrx}	gain control range for transmit and receive amplifiers with respect to $I_{line} = 15 \text{ mA}$	$I_{line} = 75 \text{ mA}$	–	5.8	–	dB

GENERAL DESCRIPTION

The TEA1118 and TEA1118A are bipolar integrated circuits that perform all speech and line interface functions required in cordless telephone base stations. The ICs operate at a line voltage down to 1.6 V DC (with reduced performance) to facilitate the use of telephone sets connected in parallel.

The TEA1118A offers in addition to the TEA1118 electronic switching between speech and dialling. Moreover the transmit amplifier can be disabled during speech condition by means of a transmit mute function.

All statements and values refer to all versions unless otherwise specified.

Versatile cordless transmission circuit

TEA1118; TEA1118A

ORDERING INFORMATION

TYPE NUMBER	PACKAGE		
	NAME	DESCRIPTION	VERSION
TEA1118M	SSOP16	plastic shrink small outline package; 16 leads; body width 4.4 mm	SOT369-1
TEA1118T	SO14	plastic small outline package; 14 leads; body width 3.9 mm	SOT108-1
TEA1118AM	SSOP16	plastic shrink small outline package; 16 leads; body width 4.4 mm	SOT369-1
TEA1118AT	SO14	plastic small outline package; 14 leads; body width 3.9 mm	SOT108-1

BLOCK DIAGRAMS

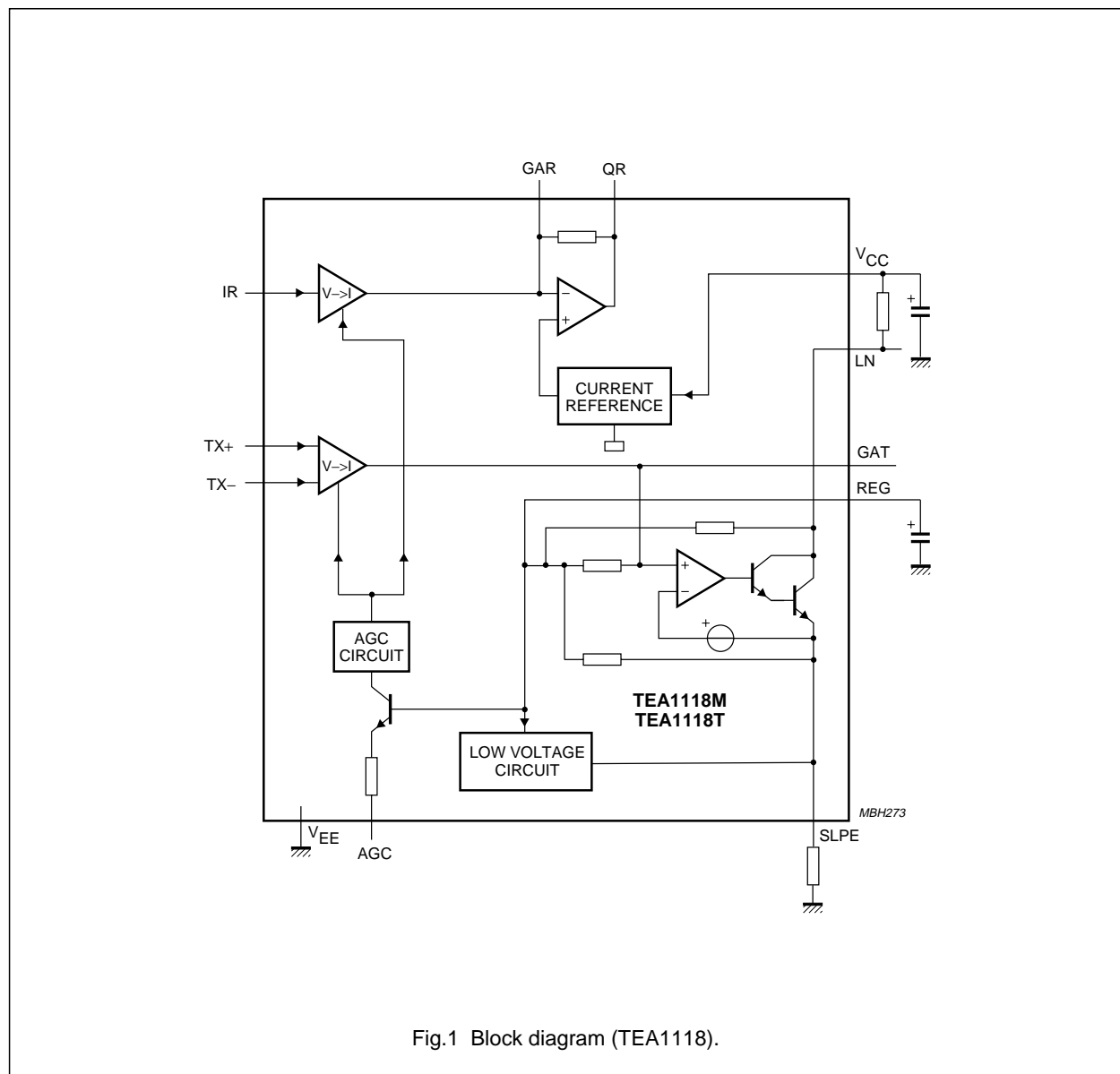

Fig.1 Block diagram (TEA1118).

Versatile cordless transmission circuit

TEA1118; TEA1118A

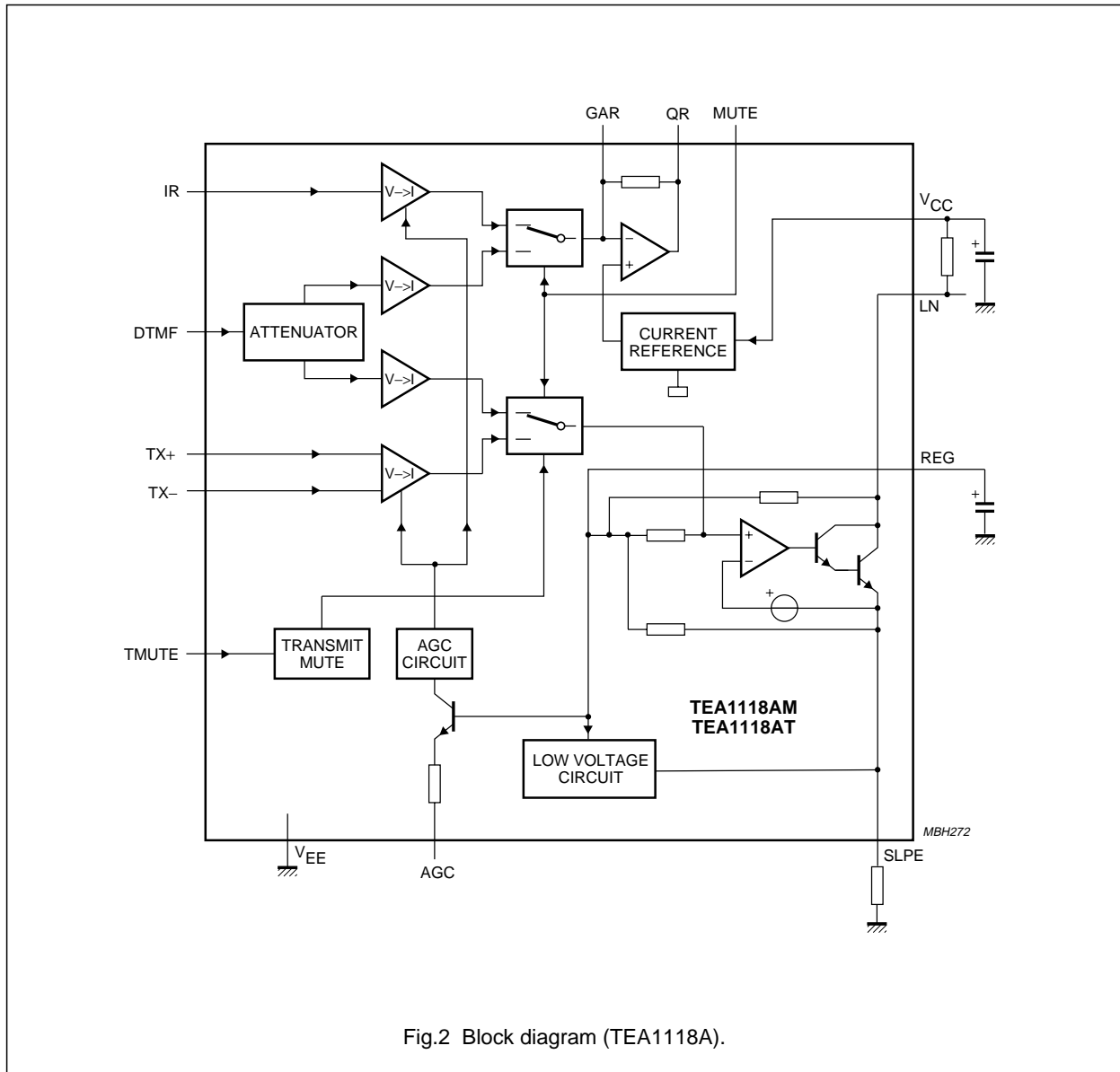

Fig.2 Block diagram (TEA1118A).

Versatile cordless transmisssion circuit

TEA1118; TEA1118A

PINNING

SYMBOL	TEA1118		TEA1118A		DESCRIPTION
	SO14	SSOP16	SO14	SSOP16	
LN	1	1	1	1	positive line terminal
SLPE	2	2	2	2	slope (DC resistance) adjustment
REG	3	3	3	3	line voltage regulator decoupling
GAT	4	4	–	–	transmit gain adjustment
TMUTE	–	–	4	5	transmit mute input
DTMF	–	–	5	6	dual-tone multi-frequency input
MUTE	–	–	6	8	mute input to select speech or dialling mode
IR	7	9	7	9	receive amplifier input
AGC	8	10	8	10	automatic gain control/line loss compensation
TX–	9	11	9	11	inverting transmit amplifier input
TX+	10	12	10	12	non-inverting transmit amplifier input
V _{EE}	11	13	11	13	negative line terminal
QR	12	14	12	14	receive amplifier output
GAR	13	15	13	15	receive gain adjustment
V _{CC}	14	16	14	16	supply voltage for speech circuit and peripherals
n.c.	5 and 6	5 to 8	–	4 and 7	not connected

Versatile cordless transmission circuit

TEA1118; TEA1118A

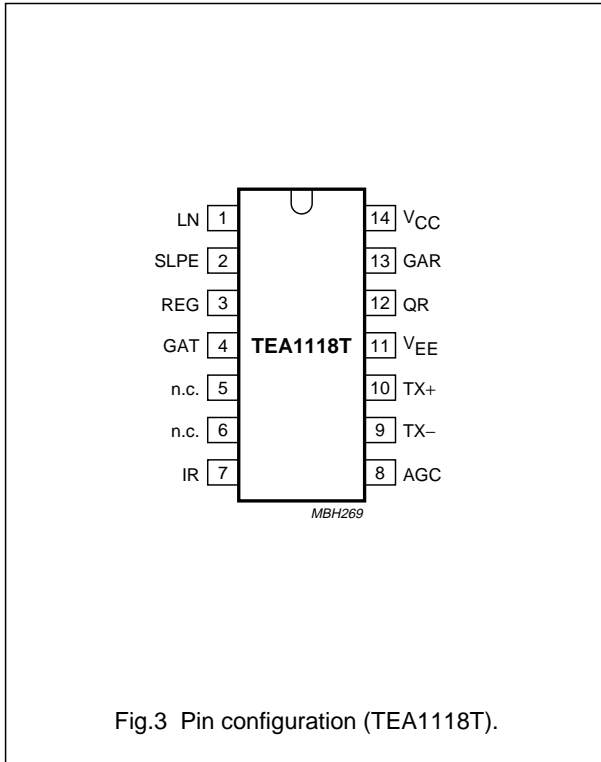

Fig.3 Pin configuration (TEA1118T).

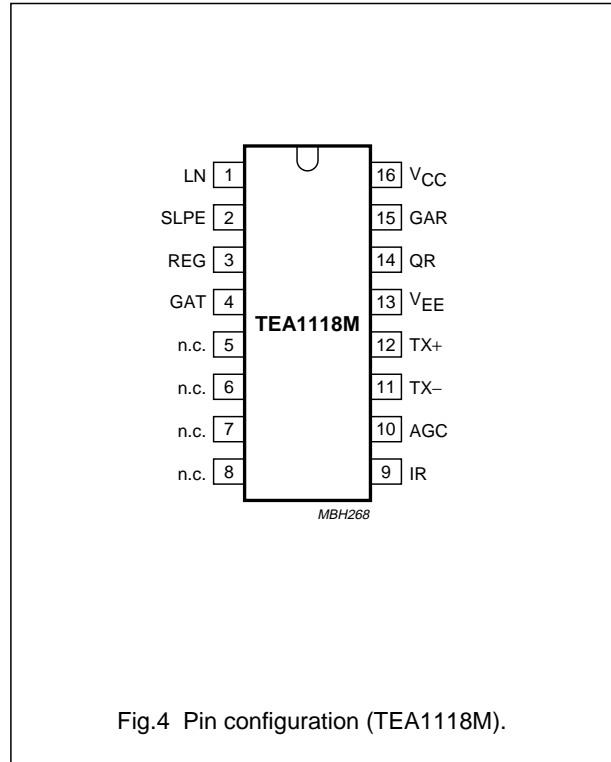

Fig.4 Pin configuration (TEA1118M).

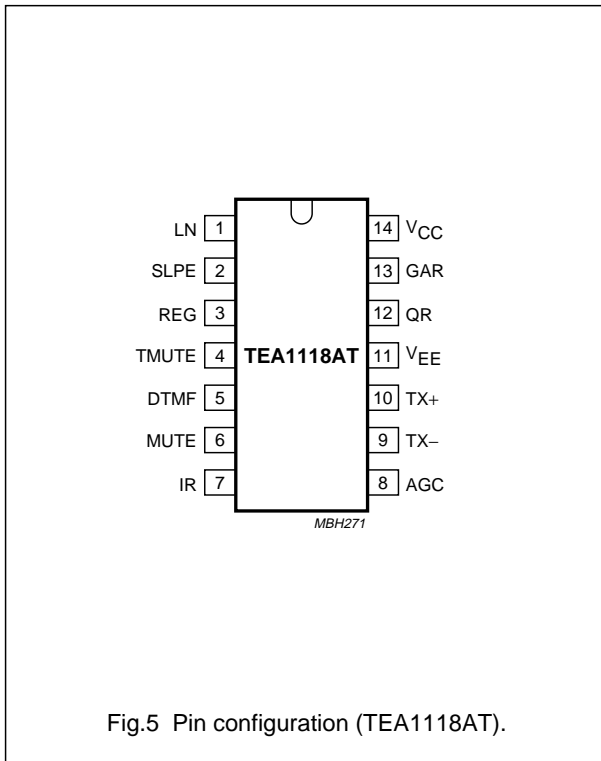

Fig.5 Pin configuration (TEA1118AT).

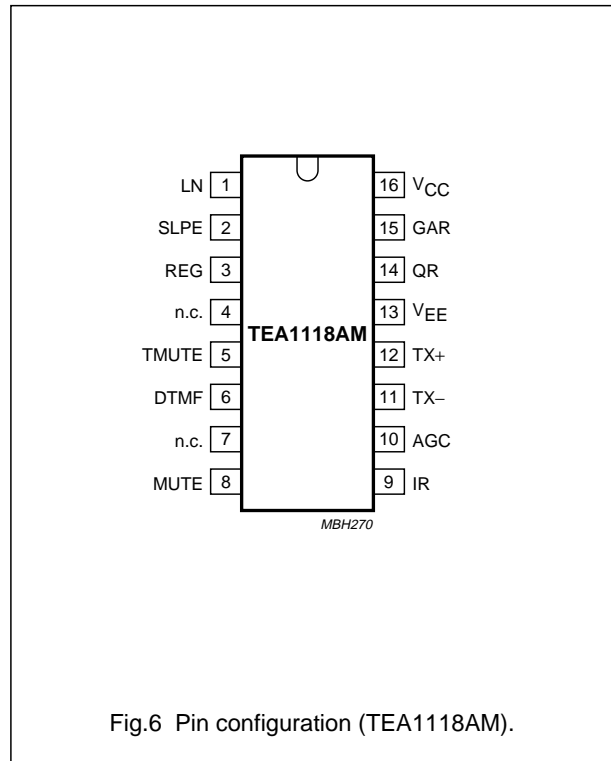

Fig.6 Pin configuration (TEA1118AM).

Versatile cordless transmisssion circuit

TEA1118; TEA1118A

FUNCTIONAL DESCRIPTION

All data given in this chapter are typical values, except when otherwise specified.

Supplies (pins LN, SLPE, V_{CC} and REG)

The supply for the TEA1118 and TEA1118A and their peripherals is obtained from the telephone line.

The ICs generate a stabilized reference voltage (V_{ref}) between pins LN and SLPE. This reference voltage is equal to 3.35 V, is temperature compensated and can be adjusted by means of an external resistor (R_{VA}). It can be increased by connecting the R_{VA} resistor between pins REG and SLPE (see Fig.11), or decreased by connecting the R_{VA} resistor between pins REG and LN. The voltage at pin REG is used by the internal regulator to generate the stabilized reference voltage and is decoupled by a capacitor (C_{REG}) which is connected to V_{EE} . This capacitor, converted into an equivalent inductance (see Section "Set impedance"), realizes the set impedance conversion from its DC value (R_{SLPE}) to its AC value (R_{CC} in the audio-frequency range). The voltage at pin SLPE is proportional to the line current. Figure 7 illustrates the supply configuration.

The ICs regulate the line voltage at pin LN, and it can be calculated as follows:

$$V_{LN} = V_{ref} + R_{SLPE} \times I_{SLPE}$$

$$I_{SLPE} = I_{line} - I_{CC} - I_P - I^* = I_{sh}$$

where:

I_{line} : line current

I_{CC} : current consumption of the IC

I_P : supply current for peripheral circuits

I^* : current consumed between LN and V_{EE}

I_{sh} : the excess line current shunted to SLPE (and V_{EE}) via LN.

The preferred value for R_{SLPE} is 20 Ω . Changing R_{SLPE} will affect more than the DC characteristics; it also influences the transmit gain and the DTMF gain (TEA1118A only), the gain control characteristics, the sidetone level and the maximum output swing on the line.

The internal circuitry of the TEA1118 and TEA1118A is supplied from pin V_{CC} . This voltage supply is derived from the line voltage by means of a resistor (R_{CC}) and must be decoupled by a capacitor C_{VCC} . It may also be used to supply peripheral circuits such as dialling or control circuits. The V_{CC} voltage depends on the current consumed by the IC and the peripheral circuits as shown

by the formula (see also Figs 8 and 9). R_{CCint} is the internal equivalent resistance of the voltage supply point, and I_{rec} is the current consumed by the output stage of the earpiece amplifier.

$$V_{CC} = V_{CC0} - R_{CCint} \times (I_P - I_{rec})$$

$$V_{CC0} = V_{LN} - R_{CC} \times I_{CC}$$

The DC line current flowing into the set is determined by the exchange supply voltage (V_{exch}), the feeding bridge resistance (R_{exch}), the DC resistance of the telephone line (R_{line}) and the reference voltage (V_{ref}). With line currents below 7.5 mA, the internal reference voltage (generating V_{ref}) is automatically adjusted to a lower value.

This means that more sets can operate in parallel with DC line voltages (excluding the polarity guard) down to an absolute minimum voltage of 1.6 V. At currents below 7.5 mA, the circuit has limited transmit and receive levels. This is called the low voltage area.

Set impedance

In the audio frequency range, the dynamic impedance is mainly determined by the R_{CC} resistor. The equivalent impedance of the circuits is illustrated in Fig.10.

Transmit amplifier (pins TX+, TX- and GAT)

The TEA1118 and TEA1118A have symmetrical transmit inputs. The input impedance between pins TX+ and TX- is equal to 62.5 k Ω ; the input impedance between pins TX+/TX- and V_{EE} is equal 36.5 k Ω . The voltage gain from pins TX+/TX- to pin LN is set at 11.3 dB.

Automatic gain control is provided on this amplifier for line loss compensation.

The gain of the TEA1118 can be decreased by connecting an external resistor R_{GAT} between pins GAT and REG. The adjustment range is equal to 6 dB. A capacitor C_{GAT} connected between pins GAT and REG can be used to provide a first-order low-pass filter. The cut-off frequency corresponds to the time constant $C_{GAT} \times (R_{GATint} // R_{GAT})$. R_{GATint} is the internal resistor which sets the gain with a typical value of 27 k Ω .

Transmit mute (pin TMUTE; TEA1118A only)

The transmit amplifier can be disabled by activating the transmit mute function. When TMUTE is LOW, the normal speech mode is entered, depending on the level on MUTE. When TMUTE is HIGH, the transmit amplifier inputs are disabled while the DTMF input is enabled (no confidence tone is provided). The voltage gain between LN and TX+/TX- is attenuated; the gain reduction is 80 dB.

Versatile cordless transmission circuit

TEA1118; TEA1118A

Receive amplifier (pins IR, GAR and QR)

The receive amplifier has one input (IR) and one output (QR). The input impedance between pins IR and V_{EE} is 20 k Ω . The voltage gain from pin IR to pin QR is set at 31 dB. The gain can be decreased by connecting an external resistor R_{GAR} between pins GAR and QR; the adjustment range is 12 dB. Two external capacitors C_{GAR} (connected between GAR and QR) and C_{GARS} (connected between GAR and V_{EE}) ensure stability.

The C_{GAR} capacitor provides a first-order low-pass filter. The cut-off frequency corresponds to the time constant $C_{GAR} \times (R_{GARint} // R_{GAR})$. R_{GARint} is the internal resistor which sets the gain with a typical value of 100 k Ω . The condition $C_{GARS} = 10 \times C_{GAR}$ must be fulfilled to ensure stability.

Automatic gain control is provided on this amplifier for line loss compensation.

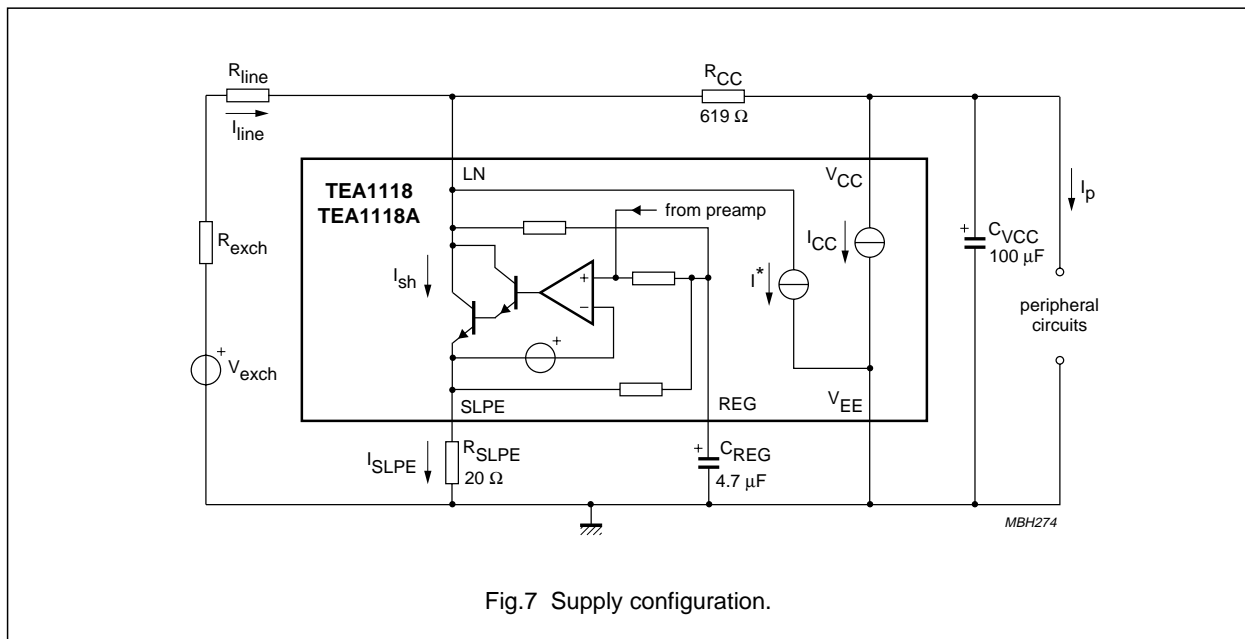
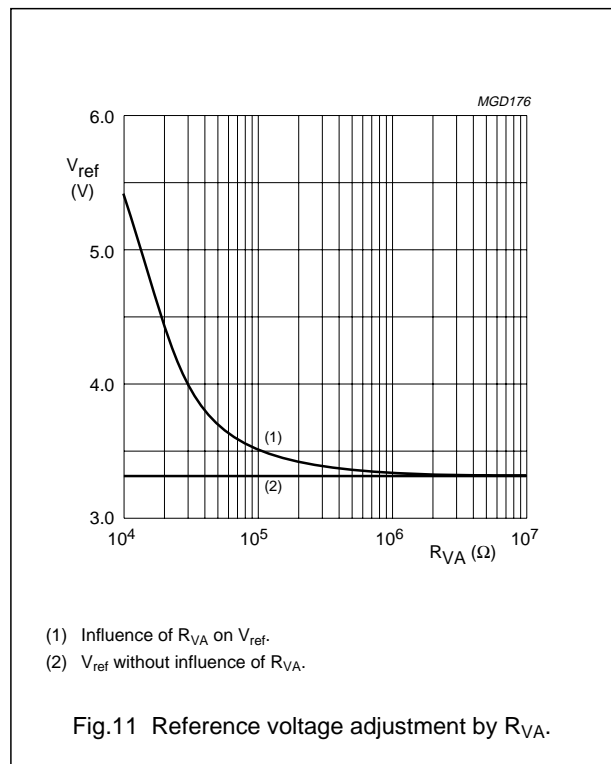
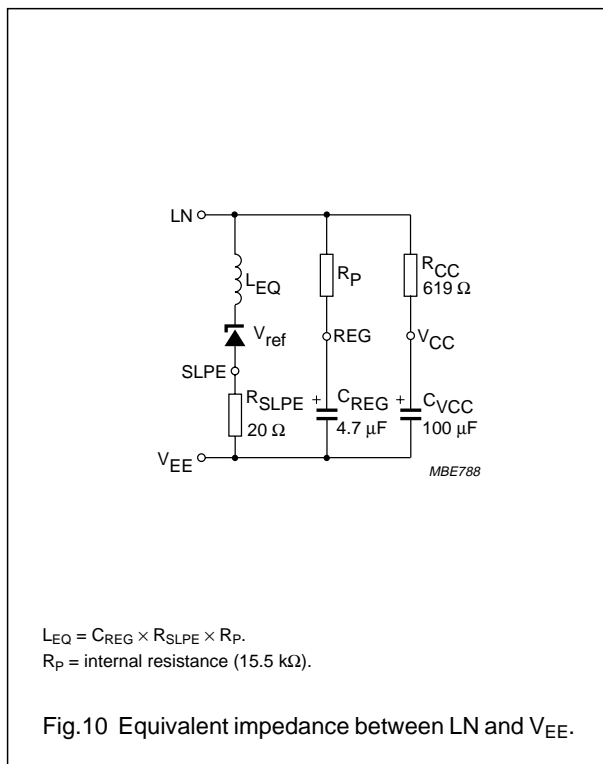
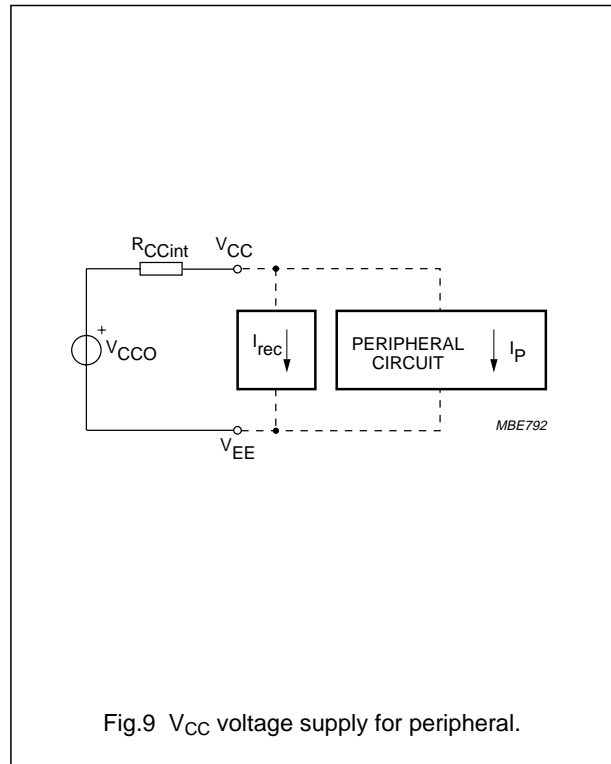
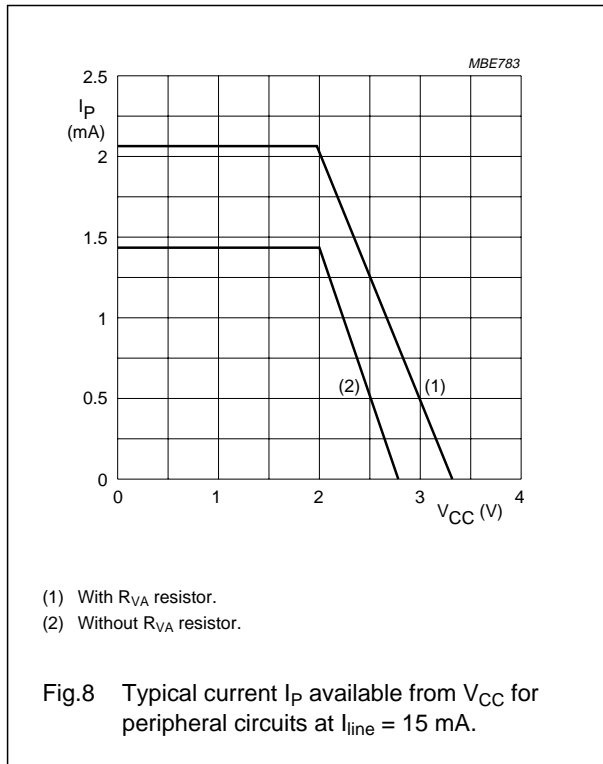

Fig.7 Supply configuration.

Versatile cordless transmission circuit

TEA1118; TEA1118A



Versatile cordless transmission circuit

TEA1118; TEA1118A

Automatic Gain Control (pin AGC)

The TEA1118 and TEA1118A perform automatic line loss compensation. The automatic gain control varies the gain of the transmit amplifier and the gain of the receive amplifier in accordance with the DC line current.

The control range is 5.8 dB (which corresponds approximately to a line length of 5 km for a 0.5 mm diameter twisted-pair copper cable with a DC resistance of 176 Ω /km and an average attenuation of 1.2 dB/km).

The ICs can be used with different configurations of feeding bridge (supply voltage and bridge resistance) by connecting an external resistor R_{AGC} between pins AGC and V_{EE} . This resistor enables the I_{start} and I_{stop} line currents to be increased (the ratio between I_{start} and I_{stop} is not affected by the resistor). The AGC function is disabled when pin AGC is left open-circuit.

DTMF amplifier (pin DTMF; TEA1118A only)

When the DTMF amplifier is enabled, dialling tones may be sent on line. These tones can be heard in the earpiece at a low level (confidence tone).

The TEA1118A has an asymmetrical DTMF input. The input impedance between DTMF and V_{EE} is 20 k Ω . The voltage gain from pin DTMF to pin LN is 17.4 dB.

The automatic gain control has no effect on the DTMF amplifier.

Mute function (pin MUTE; TEA1118A only)

The mute function performs the switching action between the speech mode and the dialling mode. When MUTE is LOW or open-circuit, the transmit and receive amplifiers inputs are enabled while the DTMF input is disabled, depending on the TMUTE level. When MUTE is HIGH, the DTMF input is enabled and the transmit and receive amplifiers inputs are disabled.

MUTE and TMUTE levels for different modes (TEA1118A only)

Table 1 Required MUTE and TMUTE levels to enable the different possible modes

MODE	CHANNEL				MUTE	TMUTE
	TRANSMIT	RECEIVE	DTMF	CONFIDENCE TONE		
Speech	on	on	off	off	LOW	LOW
DTMF dialling	off	off	on	on	HIGH	X ⁽¹⁾
Transmit mute	off	on	on	off	LOW	HIGH

Note

1. X = don't care.

Sidetone suppression

The TEA1118 and TEA1118A anti-sidetone network comprising R_{CC}/Z_{line} , R_{ast1} , R_{ast2} , R_{ast3} , R_{SLPE} and Z_{bal} (see Fig.12) suppresses the transmitted signal in the earpiece. Maximum compensation is obtained when the following conditions are fulfilled:

$$R_{SLPE} \times R_{ast1} = R_{CC} \times (R_{ast2} + R_{ast3})$$

$$k = \frac{[R_{ast2} \times (R_{ast3} + R_{SLPE})]}{(R_{ast1} \times R_{SLPE})}$$

$$Z_{bal} = k \times Z_{line}$$

The scale factor k is chosen to meet the compatibility with a standard capacitor from the E6 or E12 range for Z_{bal} .

In practice, Z_{line} varies considerably with the line type and the line length. Therefore, the value chosen for Z_{bal} should be for an average line length which gives satisfactory sidetone suppression with short and long lines.

The suppression also depends on the accuracy of the match between Z_{bal} and the impedance of the average line.

The anti-sidetone network for the TEA1118 and TEA1118A (as shown in Fig.16) attenuates the receive signal from the line by 32 dB before it enters the receive amplifier.

The attenuation is almost constant over the whole audio frequency range.

A Wheatstone bridge configuration (see Fig.13) may also be used.

More information on the balancing of an anti-sidetone bridge can be obtained in our publication "Applications Handbook for Wired Telecom Systems, IC03b", order number 9397 750 00811.

Versatile cordless transmission circuit

TEA1118; TEA1118A

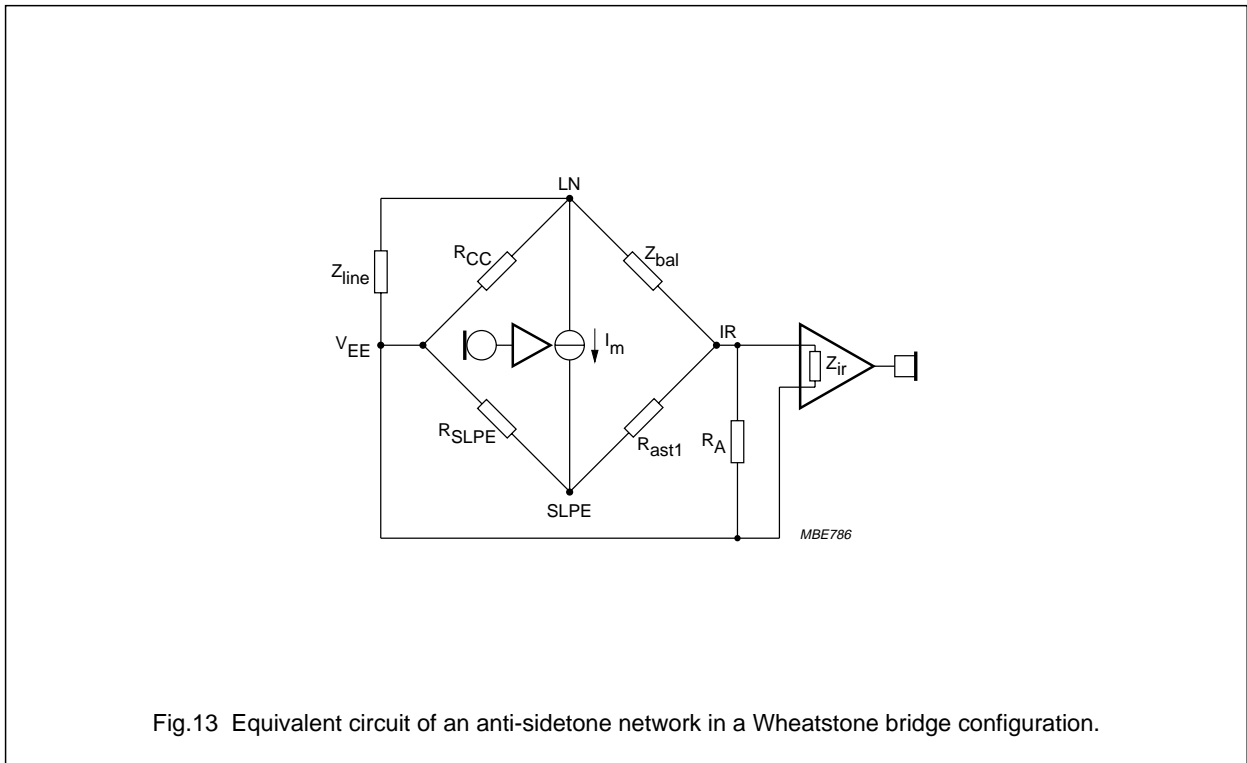
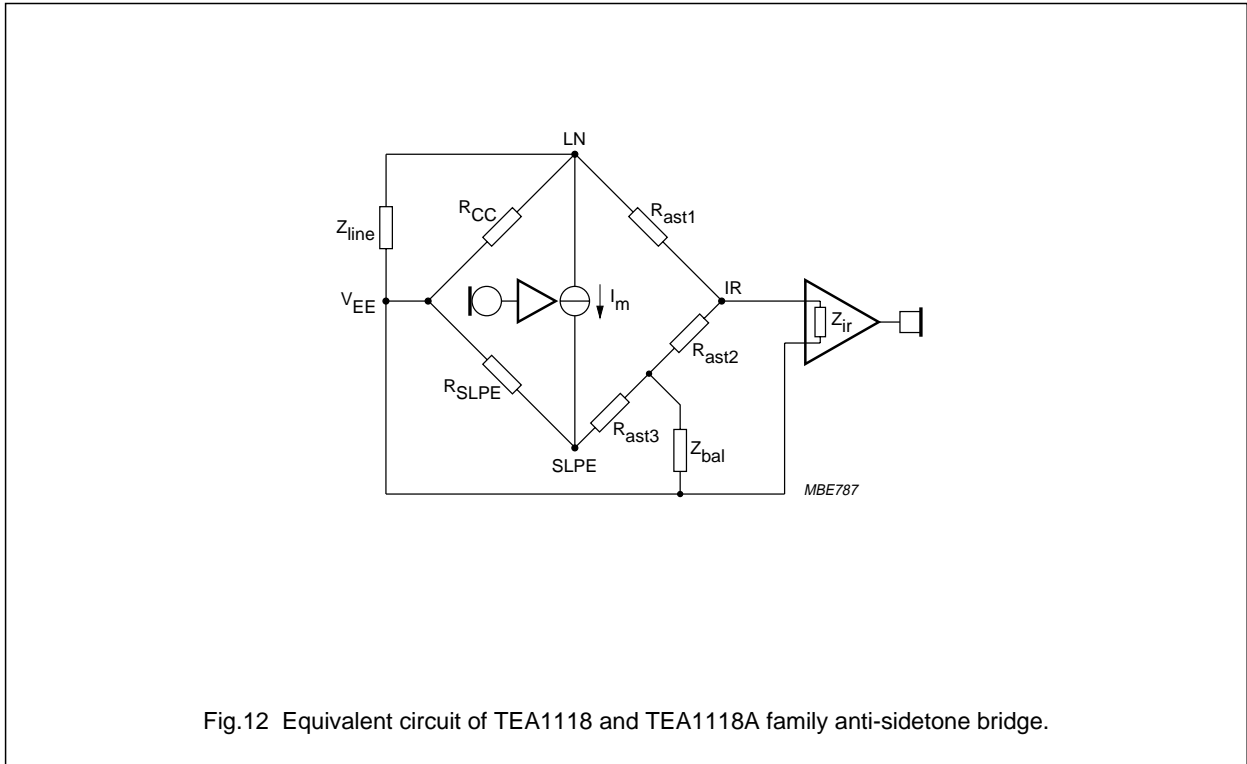

Versatile cordless transmission circuit

TEA1118; TEA1118A

LIMITING VALUES

In accordance with the Absolute Maximum Rating System (IEC 134).

SYMBOL	PARAMETER	CONDITIONS	MIN.	MAX.	UNIT
V_{LN}	positive continuous line voltage		$V_{EE} - 0.4$	12	V
	repetitive line voltage during switch-on or line interruption		$V_{EE} - 0.4$	13.2	V
$V_{n(max)}$	maximum voltage on all pins		$V_{EE} - 0.4$	$V_{CC} + 0.4$	V
I_{line}	line current	$R_{SLPE} = 20 \Omega$; see Figs 14 and 15	–	140	mA
P_{tot}	total power dissipation TEA1118T; TEA1118AT	$T_{amb} = 75 \text{ }^\circ\text{C}$; see Figs 14 and 15	–	384	mW
	TEA1118M; TEA1118AM		–	312	mW
T_{stg}	IC storage temperature		–40	+125	$^\circ\text{C}$
T_{amb}	operating ambient temperature		–25	+75	$^\circ\text{C}$

HANDLING

This device meets class 2 ESD test requirements [Human Body Model (HBM)], in accordance with "MIL STD 883C - method 3015".

THERMAL CHARACTERISTICS

SYMBOL	PARAMETER	CONDITIONS	VALUE	UNIT
$R_{th j-a}$	thermal resistance from junction to ambient in free air TEA1118T; TEA1118AT TEA1118M; TEA1118AM		130	K/W
		mounted on epoxy board 40.1 × 19.1 × 1.5 mm	160	K/W

Versatile cordless transmission circuit

TEA1118; TEA1118A

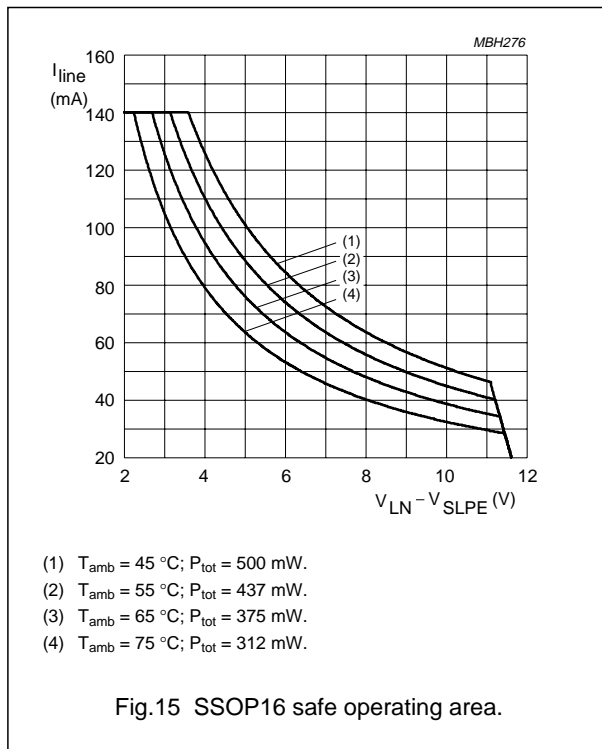
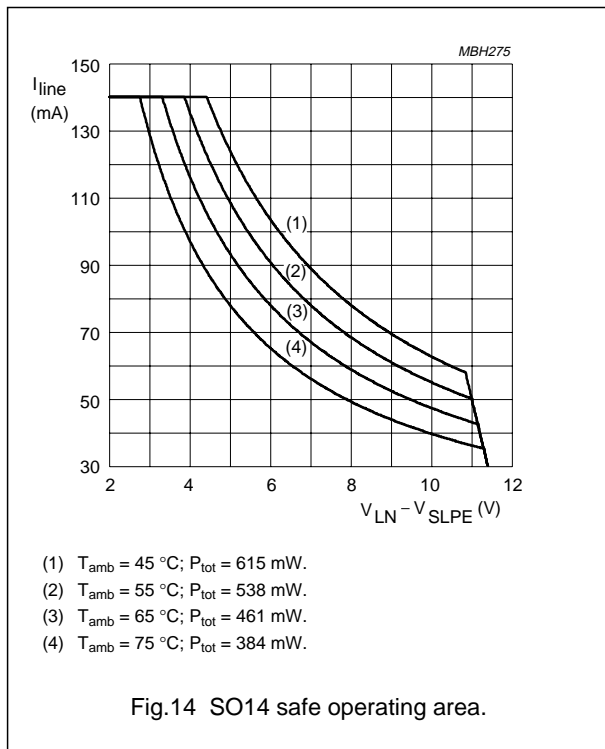

CHARACTERISTICS

$I_{line} = 15\text{ mA}$; $V_{EE} = 0\text{ V}$; $R_{SLPE} = 20\text{ }\Omega$; AGC pin connected to V_{EE} ; $Z_{line} = 600\text{ }\Omega$; $f = 1\text{ kHz}$; $T_{amb} = 25\text{ }^{\circ}\text{C}$; unless otherwise specified.

SYMBOL	PARAMETER	CONDITIONS	MIN.	TYP.	MAX.	UNIT
Supplies (pins V_{LN}, V_{CC}, $SLPE$ and REG)						
V_{ref}	stabilized voltage between LN and SLPE		3.1	3.35	3.6	V
V_{LN}	DC line voltage	$I_{line} = 1\text{ mA}$	–	1.6	–	V
		$I_{line} = 4\text{ mA}$	–	2.45	–	V
		$I_{line} = 15\text{ mA}$	3.35	3.65	3.95	V
		$I_{line} = 140\text{ mA}$	–	–	6.9	V
$V_{LN(exR)}$	DC line voltage with an external resistor R_{VA}	$R_{VA(SLPE-REG)} = 27\text{ k}\Omega$	–	4.4	–	V
$\Delta V_{LN(T)}$	DC line voltage variation with temperature referenced to $25\text{ }^{\circ}\text{C}$	$T_{amb} = -25\text{ to }+75\text{ }^{\circ}\text{C}$	–	± 30	–	mV
I_{CC}	internal current consumption	$V_{CC} = 2.9\text{ V}$	–	1.15	1.4	mA
V_{CC}	supply voltage for peripherals	$I_P = 0\text{ mA}$	–	2.9	–	V
R_{CCint}	equivalent supply voltage resistance	$I_P = 0.5\text{ mA}$	–	550	620	Ω

Versatile cordless transmission circuit

TEA1118; TEA1118A

SYMBOL	PARAMETER	CONDITIONS	MIN.	TYP.	MAX.	UNIT
Transmit amplifier (pins TX+, TX- and GAT)						
Z _i	input impedance differential between pins TX+ and TX-		–	62.5	–	kΩ
	single-ended between pins TX+/TX- and V _{EE}		–	36.5	–	kΩ
G _{vtx}	voltage gain from TX+/TX- to LN	V _{TX} = 200 mV (RMS)	10.1	11.3	12.5	dB
ΔG _{vtx(f)}	gain variation with frequency referred to 1 kHz	f = 300 to 3400 Hz	–	±0.2	–	dB
ΔG _{vtx(T)}	gain variation with temperature referred to 25 °C	T _{amb} = –25 to +75 °C	–	±0.3	–	dB
CMRR	common mode rejection ratio		–	60	–	dB
ΔG _{vtxr}	gain voltage reduction range (TEA1118 only)	external resistor connected between GAT and REG	–	–	6	dB
V _{LN(max)}	maximum sending signal (RMS value)	I _{line} = 15 mA; THD = 2%	1.4	1.7	–	V
		I _{line} = 4 mA; THD = 10%	–	0.8	–	V
V _{TX(max)}	maximum transmit input voltage (RMS value)	I _{line} = 15 mA; THD = 2%	–	0.45	–	V
		I _{line} = 75 mA; THD = 2%	–	0.9	–	V
V _{notx}	noise output voltage at pin LN; pins TX+/TX- shorted through 200 Ω	psophometrically weighted (P53 curve)	–	–84	–	dBmp
Transmit mute (pin TMUTE; TEA1118A only)						
ΔG _{vtxm}	gain reduction	TMUTE = HIGH	–	80	–	dB
V _{IL}	LOW level input voltage		V _{EE} – 0.4	–	V _{EE} + 0.3	V
V _{IH}	HIGH level input voltage		V _{EE} + 1.5	–	V _{CC} + 0.4	V
I _{TMUTE}	input current	input level = HIGH	–	1.25	3	μA
Receive amplifier (pins IR, QR and GAR)						
Z _i	input impedance		–	20	–	kΩ
G _{vrx}	voltage gain from IR to QR	V _{IR} = 4 mV (RMS)	29.8	31	32.2	dB
ΔG _{vrx(f)}	gain variation with frequency referred to 1 kHz	f = 300 to 3400 Hz	–	±0.2	–	dB
ΔG _{vrx(T)}	gain variation with temperature referred to 25 °C	T _{amb} = –25 to +75 °C	–	±0.3	–	dB
ΔG _{vrxr}	gain voltage reduction range	external resistor connected between GAR and QR	–	–	12	dB
V _{o(rms)}	maximum receive signal (RMS value)	I _P = 0 mA sine wave drive; R _L = 150 Ω; THD = 2%	–	0.25	–	V
		I _P = 0 mA sine wave drive; R _L = 450 Ω; THD = 2%	–	0.35	–	V
V _{norx(rms)}	noise output voltage at pin QR (RMS value) TEA1118 TEA1118A	IR open-circuit; R _L = 150 Ω; psophometrically weighted (P53 curve)	–	–89	–	dBVp
			–	–86	–	dBVp

Versatile cordless transmisssion circuit

TEA1118; TEA1118A

SYMBOL	PARAMETER	CONDITIONS	MIN.	TYP.	MAX.	UNIT
Automatic gain control (pin AGC)						
ΔG_{vtrx}	gain control range for transmit and receive amplifiers with respect to $I_{line} = 15 \text{ mA}$	$I_{line} = 75 \text{ mA};$	–	5.8	–	dB
I_{start}	highest line current for maximum gain		–	26	–	mA
I_{stop}	lowest line current for minimum gain		–	61	–	mA
DTMF amplifier (pin DTMF; TEA1118A only)						
$ Z_i $	input impedance		–	20	–	k Ω
G_{vdtmf}	voltage gain from DTMF to LN	$V_{DTMF} = 100 \text{ mV (RMS)};$ $MUTE \text{ or } TMUTE = \text{HIGH}$	16.2	17.4	18.6	dB
$\Delta G_{vdtmf(f)}$	gain variation with frequency referenced to 1 kHz	$f = 300 \text{ to } 3400 \text{ Hz}$	–	± 0.2	–	dB
$\Delta G_{vdtmf(T)}$	gain variation with temperature referenced to 25 °C	$T_{amb} = -25 \text{ to } +75 \text{ }^\circ\text{C}$	–	± 0.4	–	dB
G_{vct}	voltage gain from DTMF to QR (confidence tone)	$V_{DTMF} = 100 \text{ mV (RMS)};$ $R_L = 150 \text{ } \Omega$	–	–18	–	dB
Mute function (pin MUTE; TEA1118A only)						
V_{IL}	LOW level input voltage		$V_{EE} - 0.4$	–	$V_{EE} + 0.3$	V
V_{IH}	HIGH level input voltage		$V_{EE} + 1.5$	–	$V_{CC} + 0.4$	V
I_{MUTE}	input current	input level = HIGH	–	1.25	3	μA
ΔG_{trxm}	gain reduction for transmit and receive amplifiers	MUTE = HIGH	–	80	–	dB

Versatile cordless transmission circuit

TEA1118; TEA1118A

APPLICATION INFORMATION

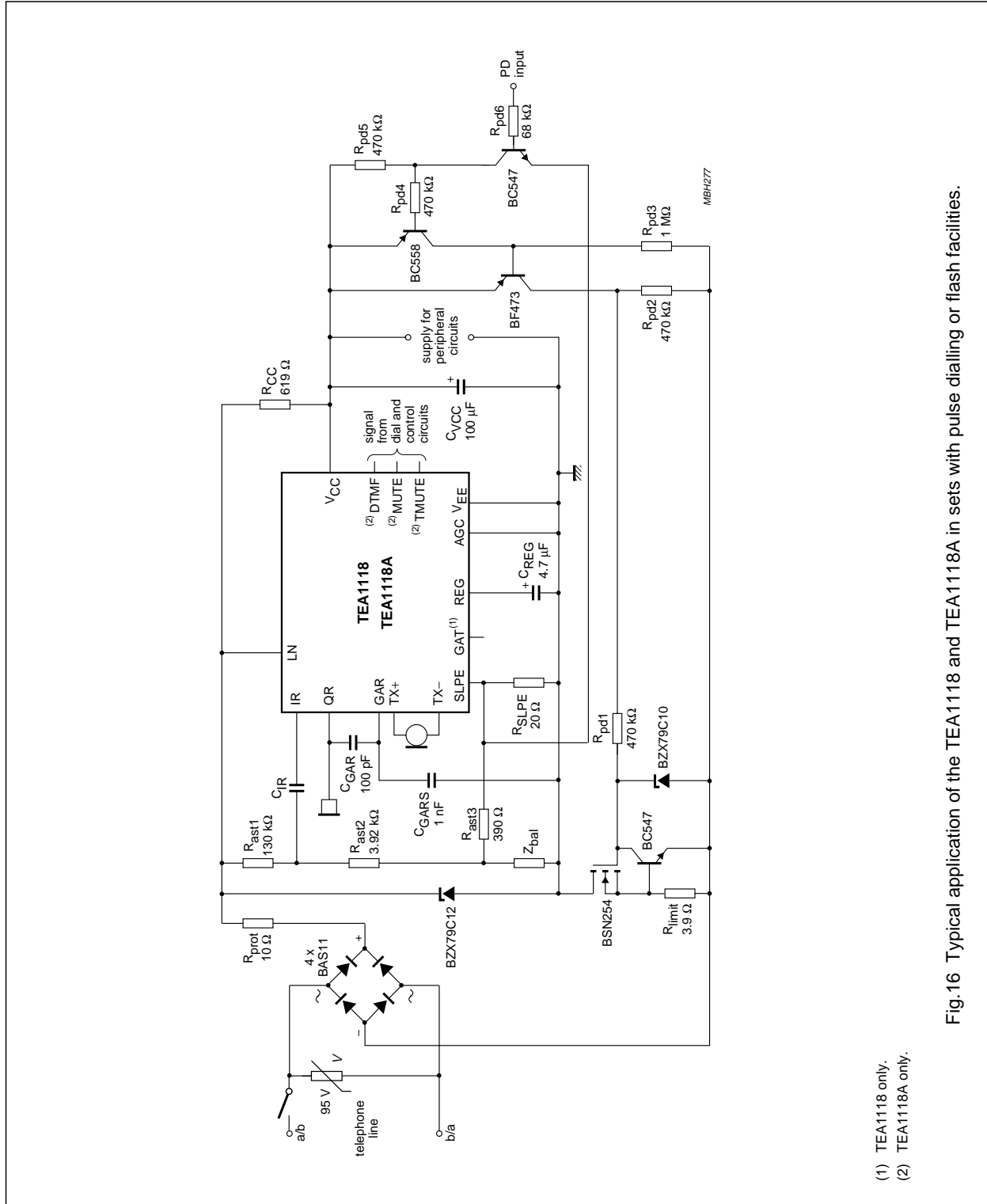

Fig. 16 Typical application of the TEA1118 and TEA1118A in sets with pulse dialling or flash facilities.

(1) TEA1118 only.
 (2) TEA1118A only.

Versatile cordless transmission circuit

TEA1118; TEA1118A

PACKAGE OUTLINES

SSOP16: plastic shrink small outline package; 16 leads; body width 4.4 mm

SOT369-1

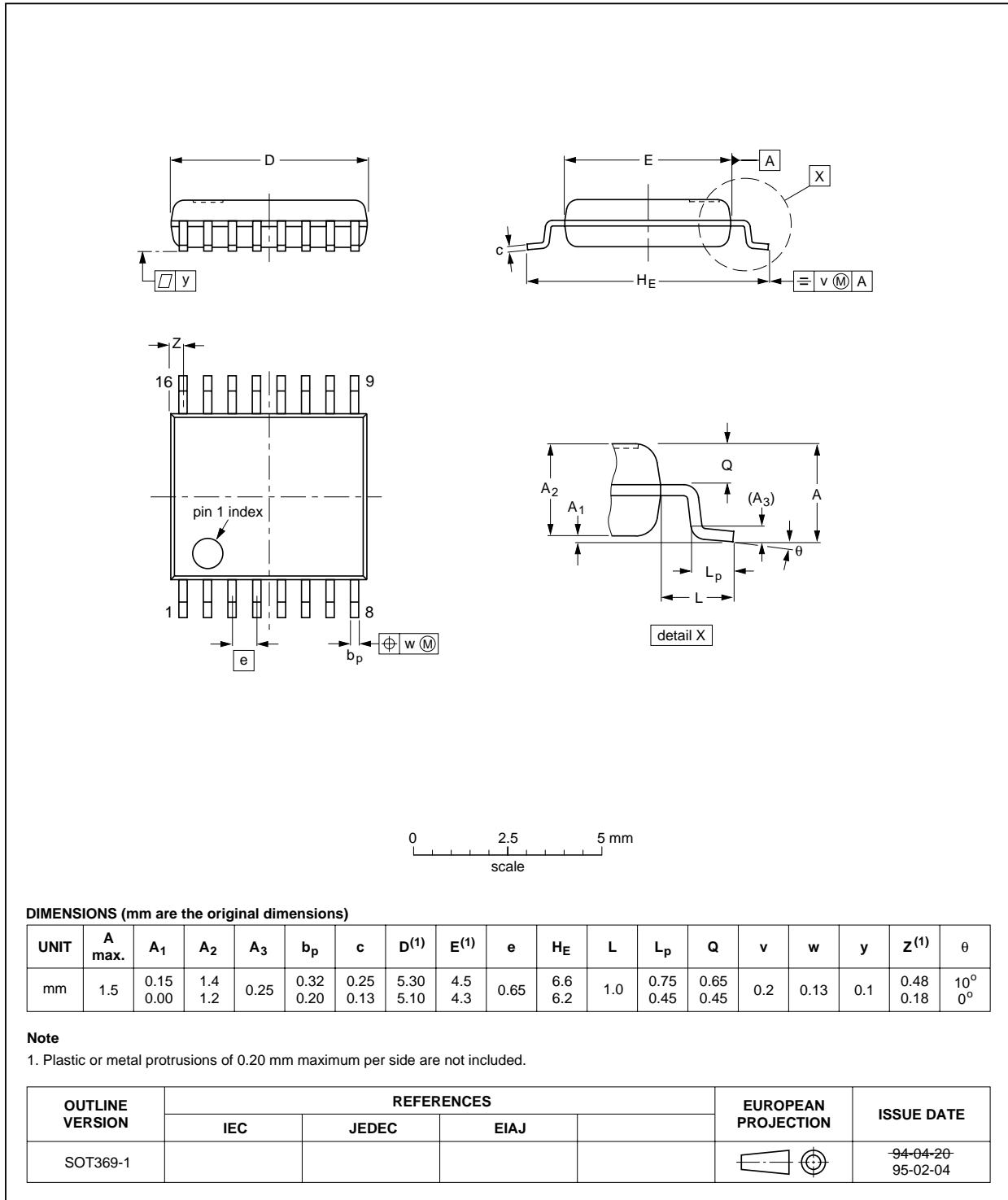

Versatile cordless transmission circuit

TEA1118; TEA1118A

SO14: plastic small outline package; 14 leads; body width 3.9 mm

SOT108-1

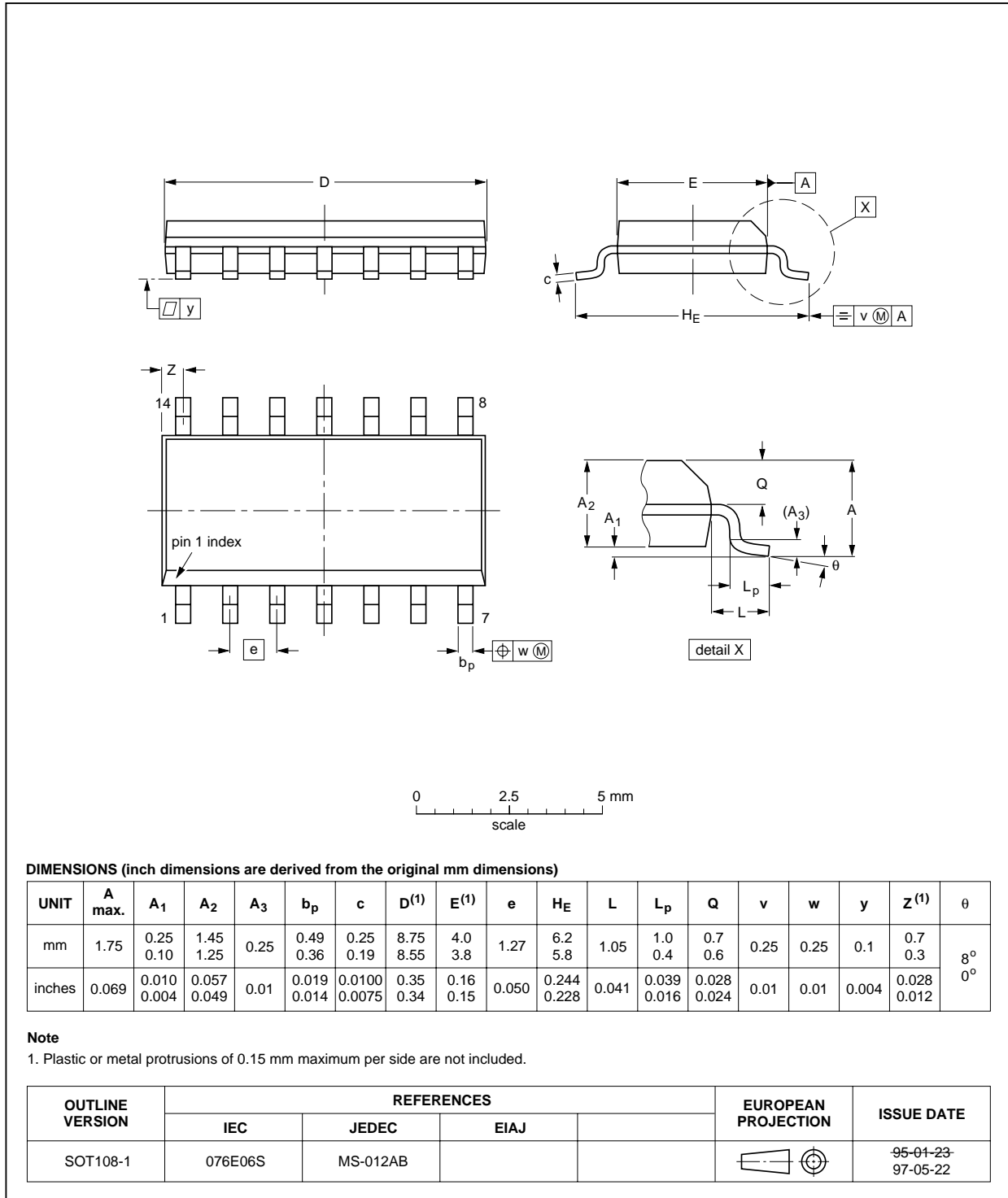

Versatile cordless transmisssion circuit

TEA1118; TEA1118A

SOLDERING**Introduction**

There is no soldering method that is ideal for all IC packages. Wave soldering is often preferred when through-hole and surface mounted components are mixed on one printed-circuit board. However, wave soldering is not always suitable for surface mounted ICs, or for printed-circuits with high population densities. In these situations reflow soldering is often used.

This text gives a very brief insight to a complex technology. A more in-depth account of soldering ICs can be found in our *"IC Package Databook"* (order code 9398 652 90011).

Reflow soldering

Reflow soldering techniques are suitable for all SO and SSOP packages.

Reflow soldering requires solder paste (a suspension of fine solder particles, flux and binding agent) to be applied to the printed-circuit board by screen printing, stencilling or pressure-syringe dispensing before package placement.

Several techniques exist for reflowing; for example, thermal conduction by heated belt. Dwell times vary between 50 and 300 seconds depending on heating method. Typical reflow temperatures range from 215 to 250 °C.

Preheating is necessary to dry the paste and evaporate the binding agent. Preheating duration: 45 minutes at 45 °C.

Wave soldering**SO**

Wave soldering techniques can be used for all SO packages if the following conditions are observed:

- A double-wave (a turbulent wave with high upward pressure followed by a smooth laminar wave) soldering technique should be used.
- The longitudinal axis of the package footprint must be parallel to the solder flow.
- The package footprint must incorporate solder thieves at the downstream end.

SSOP

Wave soldering is **not** recommended for SSOP packages. This is because of the likelihood of solder bridging due to closely-spaced leads and the possibility of incomplete solder penetration in multi-lead devices.

If wave soldering cannot be avoided, the following conditions must be observed:

- **A double-wave (a turbulent wave with high upward pressure followed by a smooth laminar wave) soldering technique should be used.**
- **The longitudinal axis of the package footprint must be parallel to the solder flow and must incorporate solder thieves at the downstream end.**

Even with these conditions, only consider wave soldering SSOP packages that have a body width of 4.4 mm, that is SSOP16 (SOT369-1) or SSOP20 (SOT266-1).

METHOD (SO AND SSOP)

During placement and before soldering, the package must be fixed with a droplet of adhesive. The adhesive can be applied by screen printing, pin transfer or syringe dispensing. The package can be soldered after the adhesive is cured.

Maximum permissible solder temperature is 260 °C, and maximum duration of package immersion in solder is 10 seconds, if cooled to less than 150 °C within 6 seconds. Typical dwell time is 4 seconds at 250 °C.

A mildly-activated flux will eliminate the need for removal of corrosive residues in most applications.

Repairing soldered joints

Fix the component by first soldering two diagonally-opposite end leads. Use only a low voltage soldering iron (less than 24 V) applied to the flat part of the lead. Contact time must be limited to 10 seconds at up to 300 °C. When using a dedicated tool, all other leads can be soldered in one operation within 2 to 5 seconds between 270 and 320 °C.

Versatile cordless transmisssion circuit

TEA1118; TEA1118A

DEFINITIONS

Data sheet status	
Objective specification	This data sheet contains target or goal specifications for product development.
Preliminary specification	This data sheet contains preliminary data; supplementary data may be published later.
Product specification	This data sheet contains final product specifications.
Limiting values	
Limiting values given are in accordance with the Absolute Maximum Rating System (IEC 134). Stress above one or more of the limiting values may cause permanent damage to the device. These are stress ratings only and operation of the device at these or at any other conditions above those given in the Characteristics sections of the specification is not implied. Exposure to limiting values for extended periods may affect device reliability.	
Application information	
Where application information is given, it is advisory and does not form part of the specification.	

LIFE SUPPORT APPLICATIONS

These products are not designed for use in life support appliances, devices, or systems where malfunction of these products can reasonably be expected to result in personal injury. Philips customers using or selling these products for use in such applications do so at their own risk and agree to fully indemnify Philips for any damages resulting from such improper use or sale.

Versatile cordless transmission circuit

TEA1118; TEA1118A

NOTES

Versatile cordless transmisssion circuit

TEA1118; TEA1118A

NOTES

Versatile cordless transmission circuit

TEA1118; TEA1118A

NOTES

Philips Semiconductors – a worldwide company

Argentina: see South America

Australia: 34 Waterloo Road, NORTH RYDE, NSW 2113,
Tel. +61 2 9805 4455, Fax. +61 2 9805 4466

Austria: Computerstr. 6, A-1101 WIEN, P.O. Box 213, Tel. +43 160 1010,
Fax. +43 160 101 1210

Belarus: Hotel Minsk Business Center, Bld. 3, r. 1211, Volodarski Str. 6,
220050 MINSK, Tel. +375 172 200 733, Fax. +375 172 200 773

Belgium: see The Netherlands

Brazil: see South America

Bulgaria: Philips Bulgaria Ltd., Energoproject, 15th floor,
51 James Bourchier Blvd., 1407 SOFIA,
Tel. +359 2 689 211, Fax. +359 2 689 102

Canada: PHILIPS SEMICONDUCTORS/COMPONENTS,
Tel. +1 800 234 7381

China/Hong Kong: 501 Hong Kong Industrial Technology Centre,
72 Tat Chee Avenue, Kowloon Tong, HONG KONG,
Tel. +852 2319 7888, Fax. +852 2319 7700

Colombia: see South America

Czech Republic: see Austria

Denmark: Prags Boulevard 80, PB 1919, DK-2300 COPENHAGEN S,
Tel. +45 32 88 2636, Fax. +45 31 57 0044

Finland: Sinikalliontie 3, FIN-02630 ESPOO,
Tel. +358 9 615800, Fax. +358 9 61580920

France: 4 Rue du Port-aux-Vins, BP317, 92156 SURESNES Cedex,
Tel. +33 1 40 99 6161, Fax. +33 1 40 99 6427

Germany: Hammerbrookstraße 69, D-20097 HAMBURG,
Tel. +49 40 23 53 60, Fax. +49 40 23 536 300

Greece: No. 15, 25th March Street, GR 17778 TAVROS/ATHENS,
Tel. +30 1 4894 339/239, Fax. +30 1 4814 240

Hungary: see Austria

India: Philips INDIA Ltd, Band Box Building, 2nd floor,
254-D, Dr. Annie Besant Road, Worli, MUMBAI 400 025,
Tel. +91 22 493 8541, Fax. +91 22 493 0966

Indonesia: see Singapore

Ireland: Newstead, Clonskeagh, DUBLIN 14,
Tel. +353 1 7640 000, Fax. +353 1 7640 200

Israel: RAPAC Electronics, 7 Kehilat Saloniki St, PO Box 18053,
TEL AVIV 61180, Tel. +972 3 645 0444, Fax. +972 3 649 1007

Italy: PHILIPS SEMICONDUCTORS, Piazza IV Novembre 3,
20124 MILANO, Tel. +39 2 6752 2531, Fax. +39 2 6752 2557

Japan: Philips Bldg 13-37, Kohnan 2-chome, Minato-ku, TOKYO 108,
Tel. +81 3 3740 5130, Fax. +81 3 3740 5077

Korea: Philips House, 260-199 Itaewon-dong, Yongsan-ku, SEOUL,
Tel. +82 2 709 1412, Fax. +82 2 709 1415

Malaysia: No. 76 Jalan Universiti, 46200 PETALING JAYA, SELANGOR,
Tel. +60 3 750 5214, Fax. +60 3 757 4880

Mexico: 5900 Gateway East, Suite 200, EL PASO, TEXAS 79905,
Tel. +9-5 800 234 7381

Middle East: see Italy

Netherlands: Postbus 90050, 5600 PB EINDHOVEN, Bldg. VB,
Tel. +31 40 27 82785, Fax. +31 40 27 88399

New Zealand: 2 Wagener Place, C.P.O. Box 1041, AUCKLAND,
Tel. +64 9 849 4160, Fax. +64 9 849 7811

Norway: Box 1, Manglerud 0612, OSLO,
Tel. +47 22 74 8000, Fax. +47 22 74 8341

Philippines: Philips Semiconductors Philippines Inc.,
106 Valero St. Salcedo Village, P.O. Box 2108 MCC, MAKATI,
Metro MANILA, Tel. +63 2 816 6380, Fax. +63 2 817 3474

Poland: Ul. Lukiska 10, PL 04-123 WARSZAWA,
Tel. +48 22 612 2831, Fax. +48 22 612 2327

Portugal: see Spain

Romania: see Italy

Russia: Philips Russia, Ul. Usatcheva 35A, 119048 MOSCOW,
Tel. +7 095 755 6918, Fax. +7 095 755 6919

Singapore: Lorong 1, Toa Payoh, SINGAPORE 1231,
Tel. +65 350 2538, Fax. +65 251 6500

Slovakia: see Austria

Slovenia: see Italy

South Africa: S.A. PHILIPS Pty Ltd., 195-215 Main Road Martindale,
2092 JOHANNESBURG, P.O. Box 7430 Johannesburg 2000,
Tel. +27 11 470 5911, Fax. +27 11 470 5494

South America: Rua do Rocio 220, 5th floor, Suite 51,
04552-903 São Paulo, SÃO PAULO - SP, Brazil,
Tel. +55 11 821 2333, Fax. +55 11 829 1849

Spain: Balmes 22, 08007 BARCELONA,
Tel. +34 3 301 6312, Fax. +34 3 301 4107

Sweden: Kottbygatan 7, Akalla, S-16485 STOCKHOLM,
Tel. +46 8 632 2000, Fax. +46 8 632 2745

Switzerland: Allmendstrasse 140, CH-8027 ZÜRICH,
Tel. +41 1 488 2686, Fax. +41 1 481 7730

Taiwan: Philips Semiconductors, 6F, No. 96, Chien Kuo N. Rd., Sec. 1,
TAIPEI, Taiwan Tel. +886 2 2134 2865, Fax. +886 2 2134 2874

Thailand: PHILIPS ELECTRONICS (THAILAND) Ltd.,
209/2 Sanpavuth-Bangna Road Prakanong, BANGKOK 10260,
Tel. +66 2 745 4090, Fax. +66 2 398 0793

Turkey: Talatpasa Cad. No. 5, 80640 GÜLTEPE/ISTANBUL,
Tel. +90 212 279 2770, Fax. +90 212 282 6707

Ukraine: PHILIPS UKRAINE, 4 Patrice Lumumba str., Building B, Floor 7,
252042 KIEV, Tel. +380 44 264 2776, Fax. +380 44 268 0461

United Kingdom: Philips Semiconductors Ltd., 276 Bath Road, Hayes,
MIDDLESEX UB3 5BX, Tel. +44 181 730 5000, Fax. +44 181 754 8421

United States: 811 East Arques Avenue, SUNNYVALE, CA 94088-3409,
Tel. +1 800 234 7381

Uruguay: see South America

Vietnam: see Singapore

Yugoslavia: PHILIPS, Trg N. Pasica 5/v, 11000 BEOGRAD,
Tel. +381 11 625 344, Fax. +381 11 635 777

For all other countries apply to: Philips Semiconductors, Marketing & Sales Communications,
Building BE-p, P.O. Box 218, 5600 MD EINDHOVEN, The Netherlands, Fax. +31 40 27 24825

Internet: <http://www.semiconductors.philips.com>

© Philips Electronics N.V. 1997

SCA55

All rights are reserved. Reproduction in whole or in part is prohibited without the prior written consent of the copyright owner.

The information presented in this document does not form part of any quotation or contract, is believed to be accurate and reliable and may be changed without notice. No liability will be accepted by the publisher for any consequence of its use. Publication thereof does not convey nor imply any license under patent- or other industrial or intellectual property rights.

Printed in The Netherlands

417027/1200/03/pp24

Date of release: 1997 Jul 14

Document order number: 9397 750 02613

Let's make things better.

**Philips
Semiconductors**



PHILIPS