

DATA SHEET

TEA1104; TEA1104T

Cost effective battery monitor and
fast charge IC for NiCd and NiMH
chargers

Objective specification
File under Integrated Circuits, IC03

1996 Feb 26

Cost effective battery monitor and fast charge IC for NiCd and NiMH chargers

TEA1104; TEA1104T

FEATURES

- Accurate detection of fully charged batteries by currentless peak voltage sensing
- Switch-over from fast to safe trickle charge current at battery full detection
- Fast charge termination back-up by maximum time and maximum temperature detection
- Several trickle charge drive possibilities for mains isolated and non-mains isolated systems
- Battery checking to protect against short-circuited and open batteries
- Battery monitor allows recharging of different battery packs in the same charger
- Dual LED indicator provision
- External regulator not required because of large input voltage range
- Few low cost external components required.

APPLICATIONS

- Portable telephone
- Portable computer
- Portable audio
- Portable video.

GENERAL DESCRIPTION

The TEA1104 is manufactured in a BiCMOS process intended to be used as a battery monitor circuit in charge systems for NiCd and NiMH batteries. It is especially designed for cost effective compact consumer applications.

The circuit is able to detect fully charged batteries by currentless battery voltage sensing. Several output drive functions are available to control the (reduced) trickle charge current to keep the batteries full with maximum life expectations.

The battery full detection is backed up by two independent mechanisms to make the system fail safe; maximum time and maximum temperature.

QUICK REFERENCE DATA

SYMBOL	PARAMETER	CONDITIONS	MIN.	TYP.	MAX.	UNIT
V_P	supply voltage		5.45	–	11.5	V
I_P	supply current	outputs off	–	–	3	mA
V_{bat}	voltage range of battery full detection		0.81	–	3.6	V
$\Delta V_{bat}/V_{bat}$	voltage peak detection level with respect to top value		–	0.25	–	%
I_{bat}	battery monitor input current		–	–	1	nA
$V_{bat(l)}$	battery voltage protection low		–	0.81	0.91	V
$V_{bat(h)}$	battery voltage protection high		3.5	3.6	–	V
f_{osc}	oscillator frequency		10	–	100	kHz

ORDERING INFORMATION

TYPE NUMBER	PACKAGE		
	NAME	DESCRIPTION	VERSION
TEA1104	DIP8	plastic dual in-line package; 8 leads (300 mil)	SOT97-1
TEA1104T	SO8	plastic small outline package; 8 leads; body width 3.9 mm	SOT96-1

Cost effective battery monitor and fast charge IC for NiCd and NiMH chargers

TEA1104; TEA1104T

BLOCK DIAGRAM

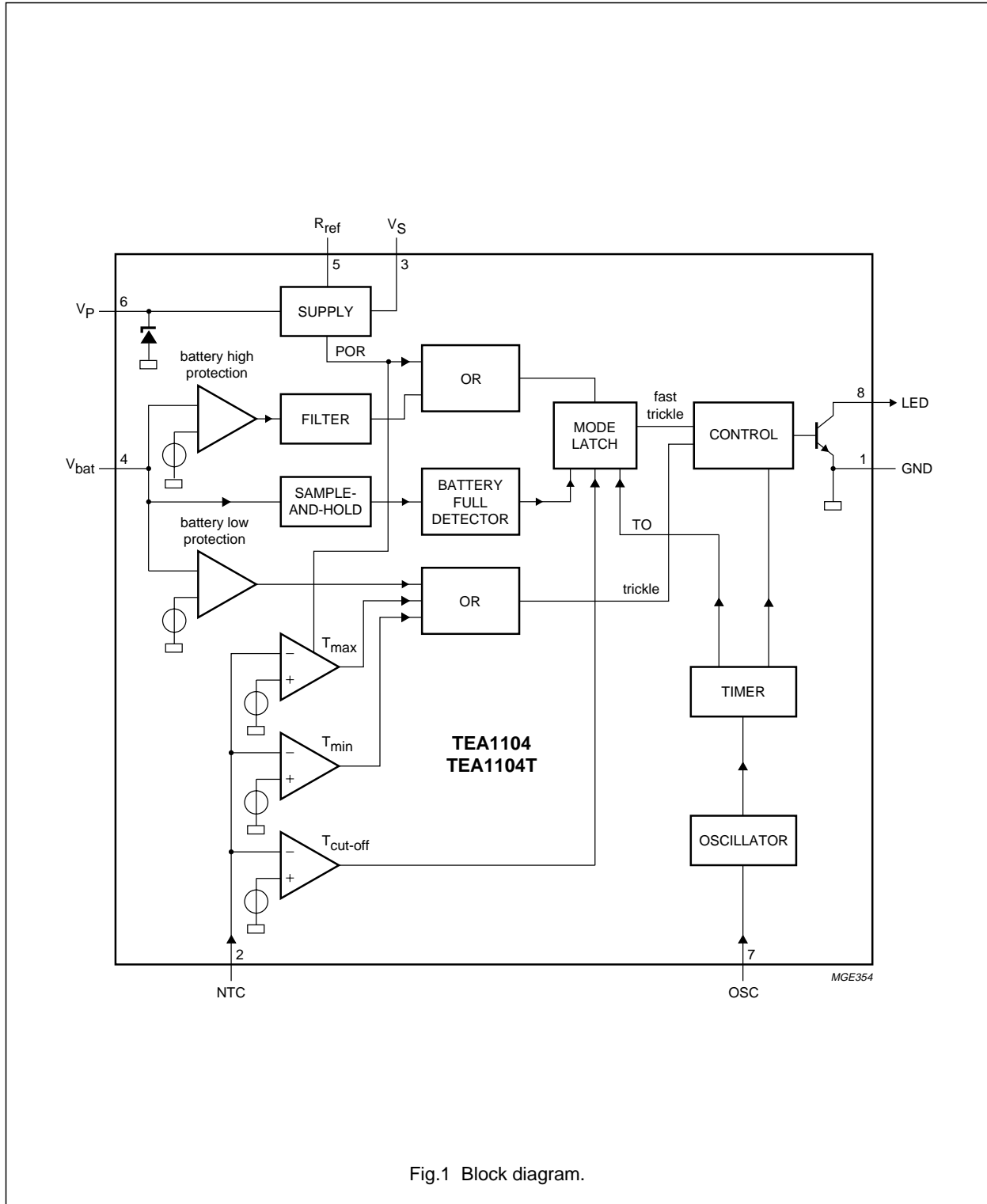

Fig.1 Block diagram.

Cost effective battery monitor and fast charge IC for NiCd and NiMH chargers

TEA1104; TEA1104T

PINNING

SYMBOL	PIN	DESCRIPTION
GND	1	ground
NTC	2	negative temperature coefficient resistor input
V_S	3	stabilized supply voltage
V_{bat}	4	battery voltage sensing
R_{ref}	5	reference resistor
V_P	6	positive supply voltage
OSC	7	oscillator input
LED	8	LED output

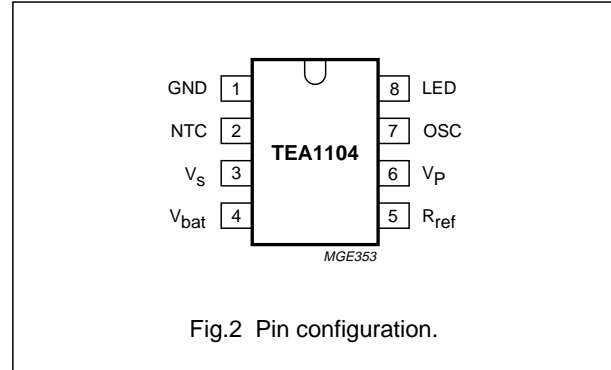

INTRODUCTION

The operation of the TEA1104; TEA1104T is explained with the aid of the application diagram illustrated in Fig.7.

An application note (AN95085) is available describing the versatility of the TEA1104; TEA1104T.

An external power current source charges the batteries via an electronic switch which is controlled by the TEA1104. The TEA1104 monitors the battery voltage. Fully charged batteries are detected when the battery voltage peaks. In fact, a voltage drop of 0.25% with respect to the top value is detected. Fast charging is initiated at 'power on' or at 'replaced batteries'. The switch is continuously on, providing that all protection levels are met. At battery full detection, the charge current is duty cycled to reduce the average charge current to a lower level, keeping the batteries fully charged but at the same time assuring long battery life. In Fig.3 the battery voltage during fast charge is plotted.

FUNCTIONAL DESCRIPTION

A block diagram of the TEA1104; TEA1104T is illustrated in Fig.1

Mode latch

The Mode latch determines if the system is in the fast or in the slow charge mode.

- Fast charge is active at:
 - power switch-on and battery connected
 - temperature between minimum and maximum value
 - battery insert

- Trickle charge is active if:
 - battery full is detected
 - maximum time is exceeded
 - maximum cut-off temperature is exceeded after the initial phase.

Supply block

For correct start-up, the IC supply current is limited to 35 μ A (typ.) until the start-up voltage of 6.4 V is reached (standby mode). Thereafter, the operating supply voltage V_P has to be within the window of 5.45 to 11.5 V, meaning that there is no need for an external voltage regulator to supply the IC.

The supply block delivers the following outputs:

- With the help of an external resistor (pin R_{ref}), a reference current is obtained which defines the accuracy of all IC timing characteristics
- Externally available 4.25 V stabilized voltage source (V_{source}). This source is used internally to supply a large part of the circuit and can be used to set the NTC biasing and to supply other external circuitry with a maximum current of 1 mA. Protection information is provided via V_S , to design a dual LED indicator
- Power-on reset pulse resets all digital circuitry after a start or restart, due to an interrupted V_S .

Cost effective battery monitor and fast charge IC for NiCd and NiMH chargers

TEA1104; TEA1104T

Open battery protection

When the rechargeable battery is removed, the output voltage V_{bat} will rise to a high level. The 'open battery protection' block will detect this voltage and the charge current will be switched off. A digital filter prevents false open battery protection. The open battery signal ($V_{\text{bat}} > 3.6 \text{ V}$) must be present for a duration of at least 4 clock pulses.

Battery monitor

One or two cell packs can be connected directly to V_{bat} (battery connection) without an external resistor divider. At larger cell packs the battery voltage must be scaled down to a voltage range of 0.81 to 3.6 V. It is also possible to take a tap on the chain of batteries. Battery full is recognized by voltage peak detection (V_{peak}), meaning a decrease of 0.25% (typ.) with respect to the top value. Keeping in mind a battery voltage range of 0.81 to 3.6 V and an accuracy of 10% at $V_{\text{bat}} = 2.4 \text{ V}$ for battery full detection, means that the internal ADC has to be 13 bits. Several filters are included to prevent false full detection. The series resistance of the battery and battery connection can cause battery voltage fluctuations and therefore it is necessary to stop the charging before sensing; this is called the 'inhibit time'. This will be performed automatically via the regulation output pin LED. The charging is stopped for ten oscillator periods at the end of which sampling is performed. The battery voltage will now be sensed in a currentless way.

Timer/oscillator

The oscillator has a sawtooth shape.

The period time is defined by: $t_{\text{osc}} = K \times R_{\text{ref}} \times C_{\text{osc}}$

The oscillator frequency is used in the timer block. In this block several important signals are created.

- Time-out for protecting the fast charge process in time. Time-out is normally chosen to be 25% longer than the associated fast charge time. So for a one hour charge time, time-out = 1.25 hours. The relationship with the oscillator period time is:
 - Time-out = $2 \exp 28 \times t_{\text{osc}}$
- The duty factor in the trickle charge mode: The duty factor is fixed to $\frac{1}{40}$, meaning that the average:
 - $I_{\text{trickle}} = \frac{1}{40} \times I_{\text{fast}}$
 - $t_{\text{on}} = \frac{3}{4} \times 2 \exp 9 \times t_{\text{osc}}$
 - $t_{\text{off}} = 2 \exp 14 \times t_{\text{osc}}$

- The battery voltage is sensed each 'cycle time'. The cycle time is defined as:
 - $T_{\text{cycle}} = 2 \exp 16 \times t_{\text{osc}}$
- The 'inhibit time' is the time that the charger current is disabled, after which the battery voltage is sensed in a currentless way.

$$- t_{\text{inhibit}} = 10 \times t_{\text{osc}}$$

Battery sampling takes one oscillator period for each cycle interval.

$$- t_{\text{sample}} = t_{\text{osc}}$$

- The 'disable time' is present to correct start-up with flat or polarized batteries. During the disable time, the battery full detection is not active.

$$- t_{\text{disable}} = 2 \exp -5 \times \text{time-out}$$

The timer is reset by battery full detection, but is on hold during the temperature and battery-low protection modes.

Temperature protection block

Temperature sensing is achieved by using a cheap thermistor. Two temperature windows are built in:

- If the temperature at power-on reset is above the maximum temperature protection level, the trickle charge current is active. The same applies for temperatures below the minimum temperature. Fast charging starts when the temperature is in between the minimum and the maximum temperature levels.
- If the temperature is between the maximum and minimum temperature at power-on reset, the fast charge current level is active. If the temperature sinks below the minimum temperature level, again the trickle charge level is active. At rising temperature, the fast charge current is latched off at the 'cut off' temperature level.

To avoid switching on and off with temperature, a hysteresis is built in for low temperature level. If the temperature protection is not necessary, pin 'Negative Temperature Coefficient resistor' (NTC) must be connected to pin R_{ref} .

Battery low protections

When the battery voltage is less than 0.81 V, the circuit assumes that there are short circuited batteries and the charge current is reduced to the trickle charge level. If the batteries are flat, the trickle charge current is able to raise the battery voltage within an acceptable period of time, after which fast charging starts.

Cost effective battery monitor and fast charge IC for NiCd and NiMH chargers

TEA1104; TEA1104T

Output drivers

Several output drive possibilities are supported by the TEA1104, to limit the fast charge current and to indicate the mode that the charge is in.

In mains isolated systems, output drive current is available for a bipolar or MOS switching device. Moreover, current regulators can be driven (see Fig.4).

In non mains isolated systems, the current source can be switched via the auxiliary winding (see Fig.6) using the TEA140X power plugs.

In the application section, an example is shown driving two LEDs that are indicating fast charging, protection during fast charging, full status and removed batteries. It is also possible to output the same information via one LED only.

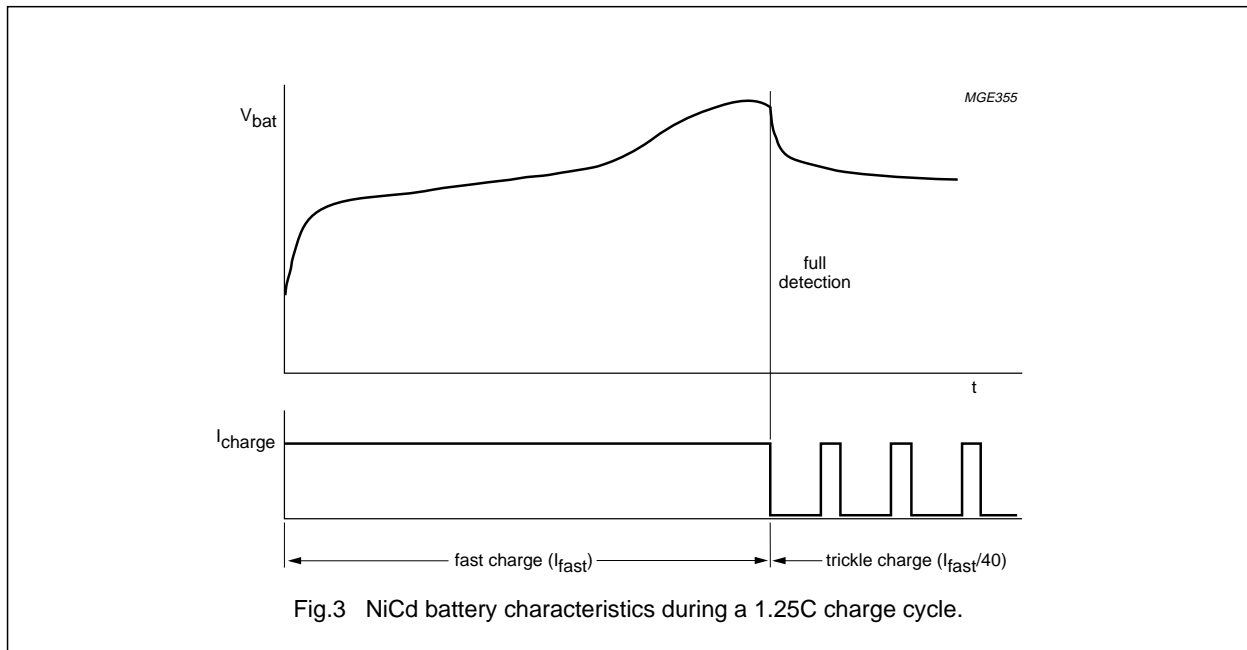

Fig.3 NiCd battery characteristics during a 1.25C charge cycle.

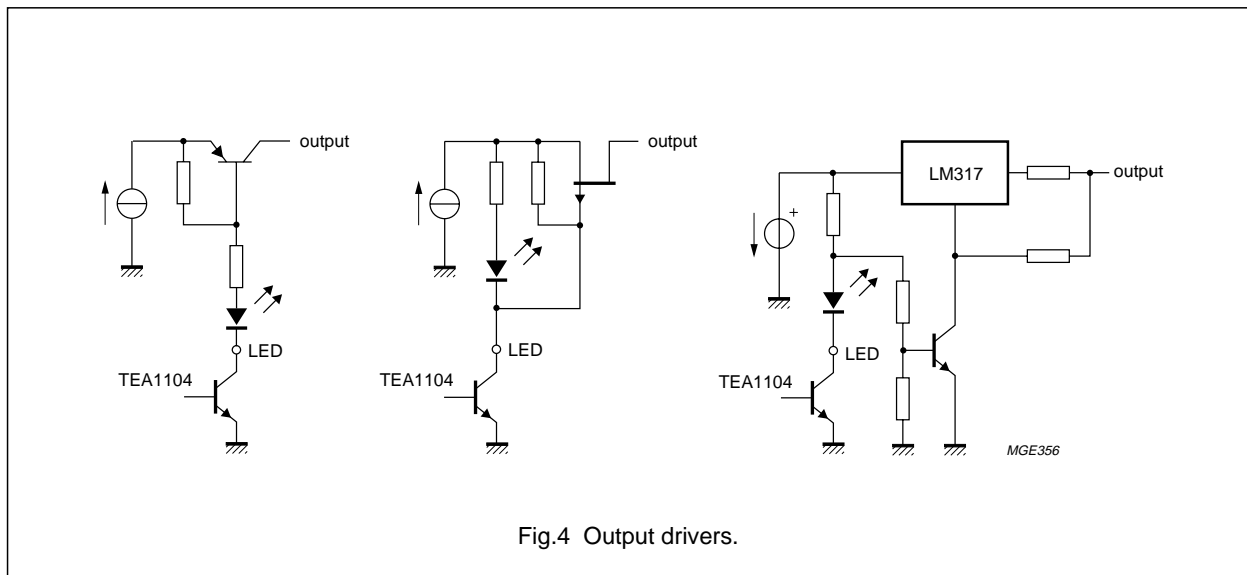
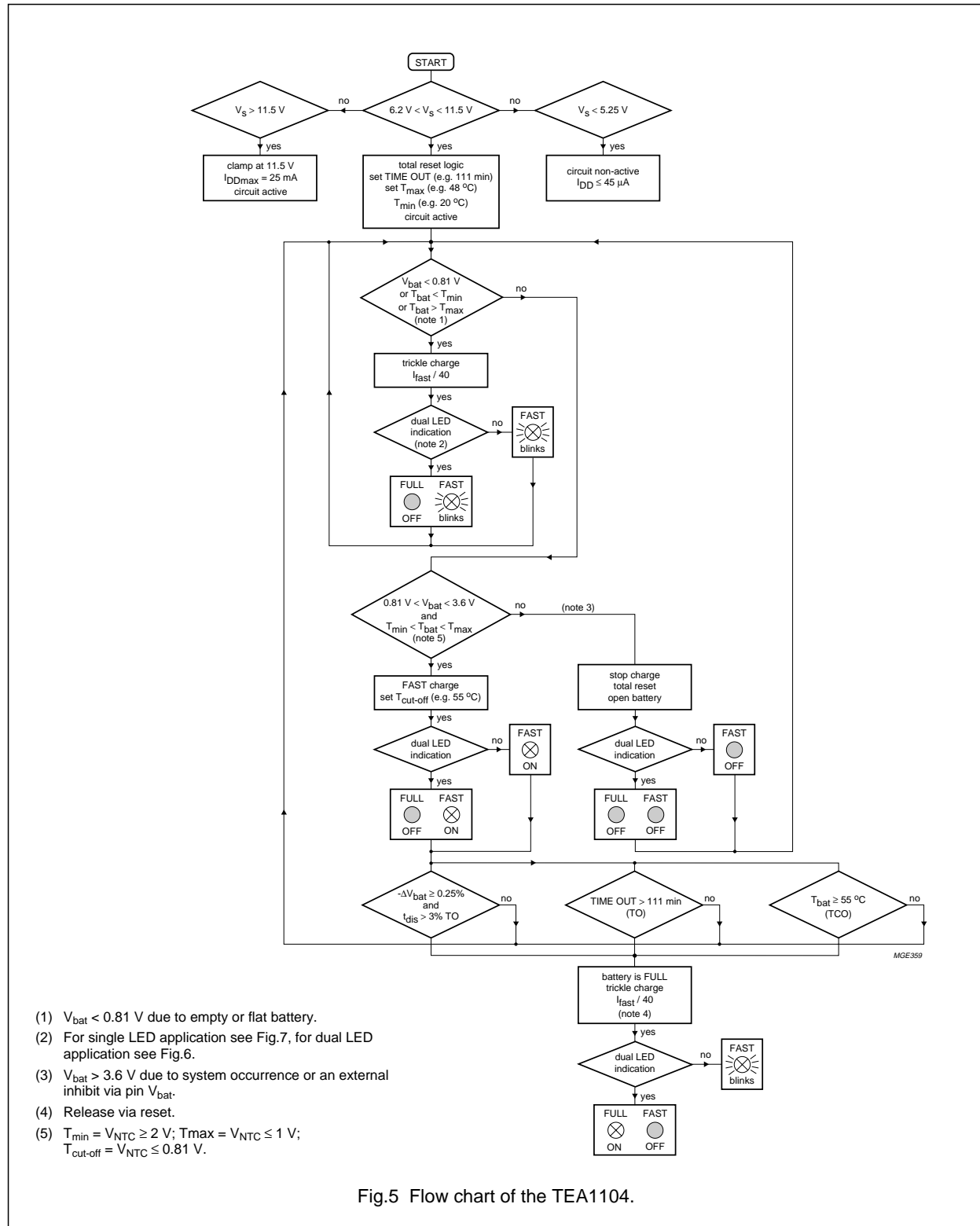

Fig.4 Output drivers.

Cost effective battery monitor and fast charge IC for NiCd and NiMH chargers

TEA1104; TEA1104T



Cost effective battery monitor and fast charge IC for NiCd and NiMH chargers

TEA1104; TEA1104T

LIMITING VALUES

In accordance with the Absolute Maximum Rating System (IEC 134); note 1.

SYMBOL	PARAMETER	CONDITIONS	MIN.	MAX.	UNIT
V_P	supply voltage		-0.5	+13.2	V
V_{oLED}	LED output voltage (pin 8)		-0.5	V_P	V
V_{iINTC}	negative temperature coefficient resistor input voltage (pin 2)		-0.5	+5	V
$V_{i(OSC)}$	oscillator input voltage (pin 7)		-0.5	+5	V
$V_{i(bat)}$	battery input voltage (pin 4)		-0.5	+5	V
V_{Rref}	reference resistor voltage (pin 5)		-0.5	+5	V
I_{source}	output source current		-3	+0.01	mA
I_{oLED}	LED output current		-	25	mA
I_{Rref}	reference resistor current		-1	+0.01	mA
I_{bat}	battery current		-1	+1	mA
V_P	supply current		-	25	mA
P_{tot}	total power dissipation	$T_{amb} = 70\text{ °C}$ TEA1104 TEA1104T	-	0.5 0.35	W W
T_{amb}	operating ambient temperature		-20	+70	°C
$T_{j(max)}$	maximum operating junction temperature		-	+150	°C
T_{stg}	storage temperature		-55	+150	°C

Note

1. All voltages are measured with respect to ground; positive currents flow into the IC. The voltage ratings are valid provided that other ratings are not violated; current ratings are valid provided that the power rating is not violated.

QUALITY SPECIFICATION

In accordance with "SNW-FQ-611 part E". The numbers of the quality specification can be found in the "Quality Reference Handbook". The handbook can be ordered using the code 9397 750 00192.

Cost effective battery monitor and fast charge IC for NiCd and NiMH chargers

TEA1104; TEA1104T

CHARACTERISTICS

$V_P = 10\text{ V}$; $T_{\text{amb}} = 25\text{ °C}$; $R_{\text{ref}} = 33\text{ k}\Omega$; $C_{\text{OSC}} = 1\text{ nF}$; unless otherwise specified.

SYMBOL	PARAMETER	CONDITIONS	MIN.	TYP.	MAX.	UNIT
Supply						
V_P	supply voltage		5.45	–	11.5	V
$\Delta V_P/\Delta t$	supply voltage start rate		–	–	0.5	V/ μs
V_{clamp}	clamping voltage	$I_{\text{clamp}} = 25\text{ mA}$	11.5	–	12.8	V
V_{start}	start-up voltage		6.1	6.4	6.7	V
V_{pd}	power-down voltage level		4.65	5.05	5.45	V
I_P	supply current	outputs off	–	–	3	mA
I_{start}	start-up current	$V_P = 4\text{ V}$	–	45	50	μA
V_S	stabilized voltage	$I_S = 1\text{ mA}$	4.03	4.25	4.46	V
V_{Rref}	voltage range at reference resistor	$I_{\text{Rref}} = 20\text{ }\mu\text{A}$	1.18	1.25	1.31	V
$TC_{V_{\text{ref}}}$	temperature coefficient of the reference voltage	$T_{\text{amb}} = 0\text{ to }45\text{ °C}$	–	± 60	± 120	ppm/K
I_{Rref}	current range of the reference resistor		10	–	100	μA
Temperature related input; NTC						
$V_{i(\text{co})}$	input voltage level for detecting temperature cut-off		0.75	0.81	0.87	V
$V_{i(\text{co}; \text{max})}$	maximum input voltage level for detecting temperature cut-off		0.92	1.0	1.08	V
$V_{i(\text{co}; \text{min})}$	minimum input voltage level for detecting temperature cut-off		1.85	2.0	2.15	V
I_{NTC}	input current	$V_{\text{NTC}} = 1.5\text{ V}$	–5	–	+5	μA
Output drivers						
δ_{LED}	LED pulse duty factor		2.4	2.5	2.6	%
$V_{\text{LED}(\text{sat})}$	LED saturation voltage	$I_{\text{LED}(\text{sat})} = 15\text{ mA}$	–	–	600	mV
$I_{\text{LI}(\text{LED})}$	LED input leakage current	$V_{\text{LED}} = 15\text{ V}$	–	–	5	μA
Battery monitor						
$I_{i(\text{bat})}$	input battery current	$V_{\text{bat}} = 2.4\text{ V}$	–	1	–	nA
V_{bat}	voltage range for peak detection		0.81	–	3.6	V
$\Delta V_{\text{bat}}/V_{\text{bat}}$	peak detection level with respect to top level	$V_{\text{bat}} = 2\text{ V}$	–	0.25	–	%
T_j	temperature range of peak detection		0	–	50	$^{\circ}\text{C}$
Protections; BAT						
$V_{\text{bat}(\text{l})}$	low level battery protection voltage		–	0.81	0.91	V
$V_{\text{bat}(\text{h})}$	high level battery protection voltage		3.5	3.6	4.5	V
Oscillator						
k	correction factor		0.84	0.93	1.02	
f_{osc}	frequency range		10	–	100	kHz

Cost effective battery monitor and fast charge IC for NiCd and NiMH chargers

TEA1104; TEA1104T

APPLICATION INFORMATION

A guideline for the settings of TEA1104 and its external components selection is given based on an example of a 1 hour charger for a 4 cell NiCd or NiMH battery pack. The basic application diagram as illustrated in Fig.6 which is based on the application diagram illustrated in Fig.7 with some additional components; a 2 LED charge status indication has been provided.

For charging a battery within one hour the charge current rating should be as follows:

$$\text{Required minimum charge current} = \text{battery capacity} \times 1.2 / \text{charge time.}$$

Therefore, for a 1 Ah battery the external charge current supply has to deliver at least 1.2 A.

TEA1104 settings

The fast charge back-up timer period, time-out, has to be set in relation to the expected maximum charge time. Normally, a safety back-up time is chosen approximately 25% longer than the maximum expected fast charge time. For a one hour charger the time-out period can be set to 1.25 h.

Time-out relationship with the oscillator repetition time is as follows;

$$t_{\text{osc}} = \text{time-out (h)} \times 3600 / 2 \exp 28$$

$$t_{\text{osc}} = 17 \mu\text{s for time-out} = 1.25 \text{ h}$$

$$t_{\text{osc}} \text{ is set with the combination of } C_{\text{osc}} \text{ and } R_{\text{ref}}; \text{ where } t_{\text{osc}} = 0.93 \times R_{\text{ref}} \times C_{\text{osc}}.$$

R_{ref} can be chosen between 13 and 120 k Ω , but a 27 k Ω resistor is recommended. The oscillator capacitor can be calculated which is 668 pF; the nearest higher practical value is 680 pF.

In the trickle charge mode the LED output will pulsate with a repetition time; $t_{\text{trickle}} = 2 \exp 14 \times t_{\text{osc}} = 0.28 \text{ s}$.

The duty factor of the pulse is 2.5% of t_{trickle} . This duty factor also applies to the charge current as the charge current switch is driven by the LED output. Therefore, the average trickle charge current is $I_{\text{fast}} / 40$. The V_{bat} input can be adapted to the battery voltage via the resistor dividers R1 and R2. When an NTC thermistor has been incorporated into the battery, the minimum, maximum and cut-off temperature levels can be set with the resistors R3 and R4. For an NTC with a common sensitivity of 3965 and adjustment resistor values R3 = 13 k Ω , R4 = 20 k Ω the minimum, maximum and cut-off temperatures will be 5, 42 and 50 °C respectively.

The flow chart of the TEA1104; TEA1104A is given in Fig.5. The load state of the batteries can be displayed by one or two LEDs. The flow chart is not to be regarded as sequential. Each mode of operation is a purely separate continuous process.

Table 1 Dual LED indication

CHARGER MODE	V_{LED}	V_{S}	LED 1	LED 2
Fast charging	low	high	on	off
Fast charging protection	low/high	high	on/off	off
Full (trickle charging)	low/high	low	off	on
Battery open	high	high	off	off

Cost effective battery monitor and fast charge IC for NiCd and NiMH chargers

TEA1104; TEA1104T

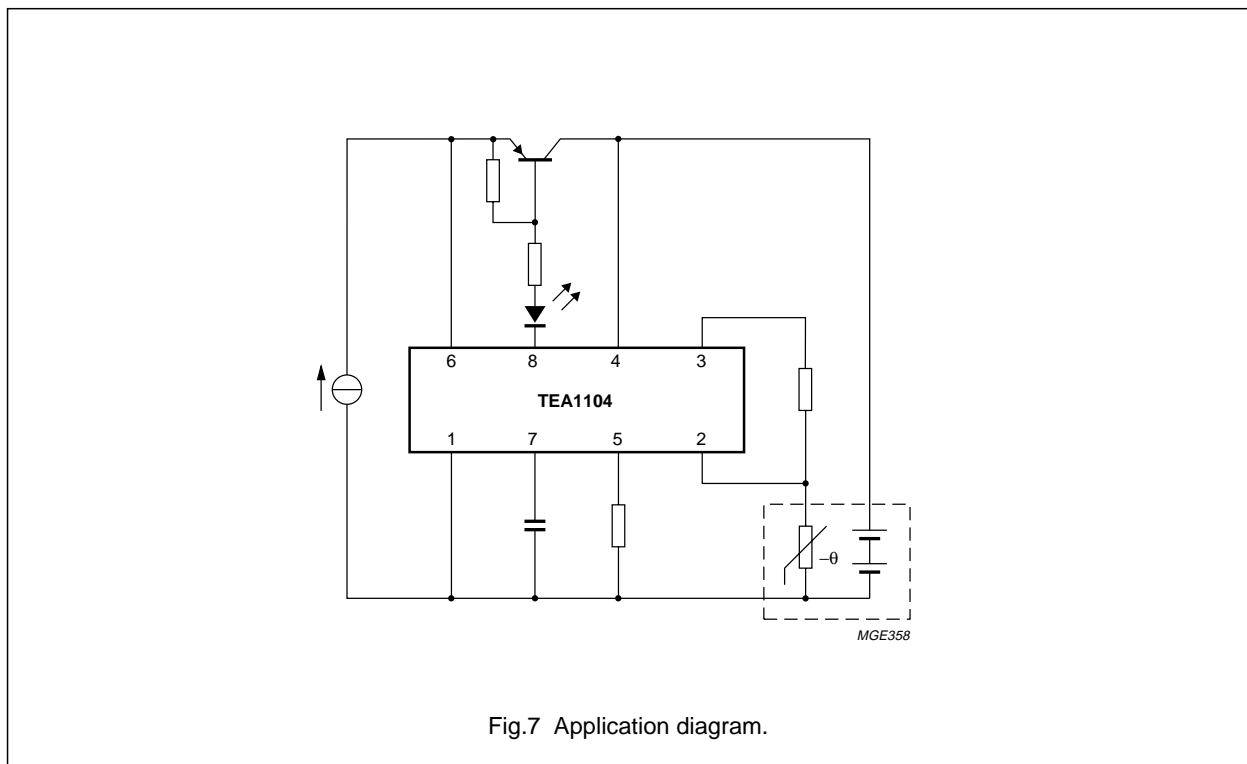
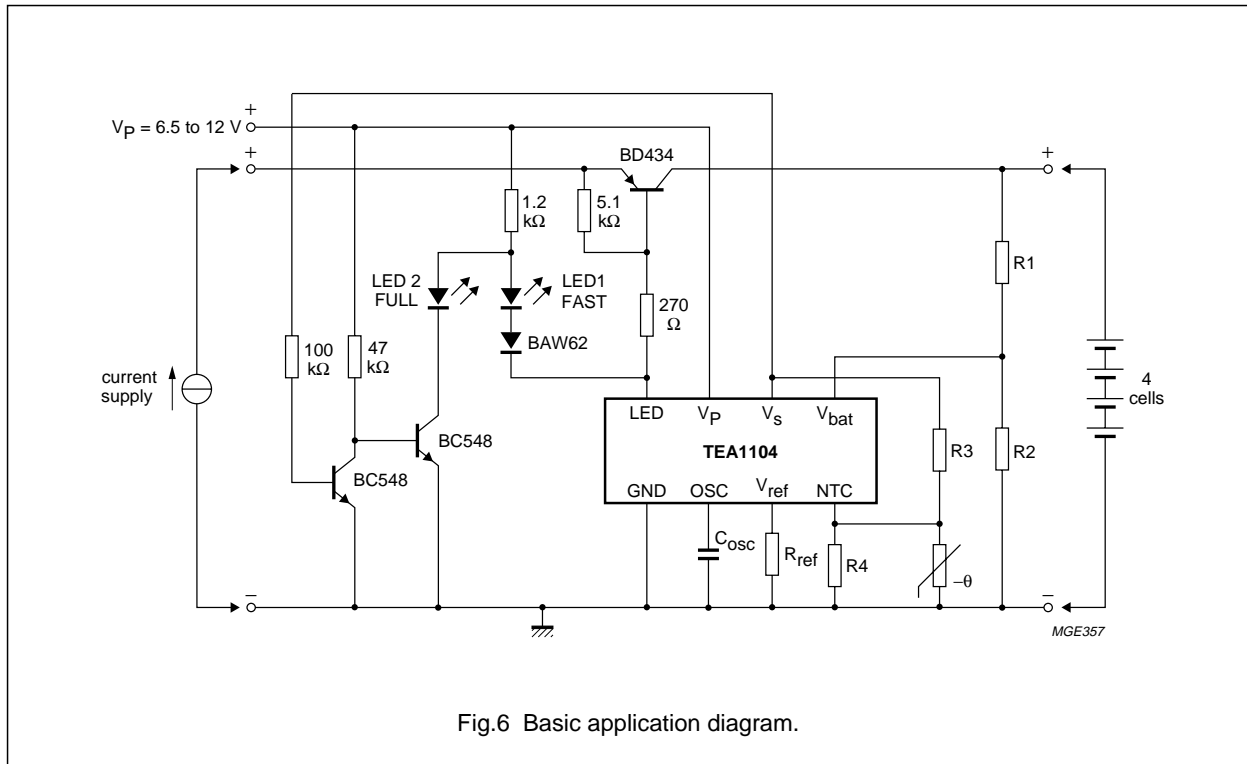

Cost effective battery monitor and fast charge IC for NiCd and NiMH chargers

TEA1104; TEA1104T

PACKAGE OUTLINES

SO8: plastic small outline package; 8 leads; body width 3.9 mm

SOT96-1

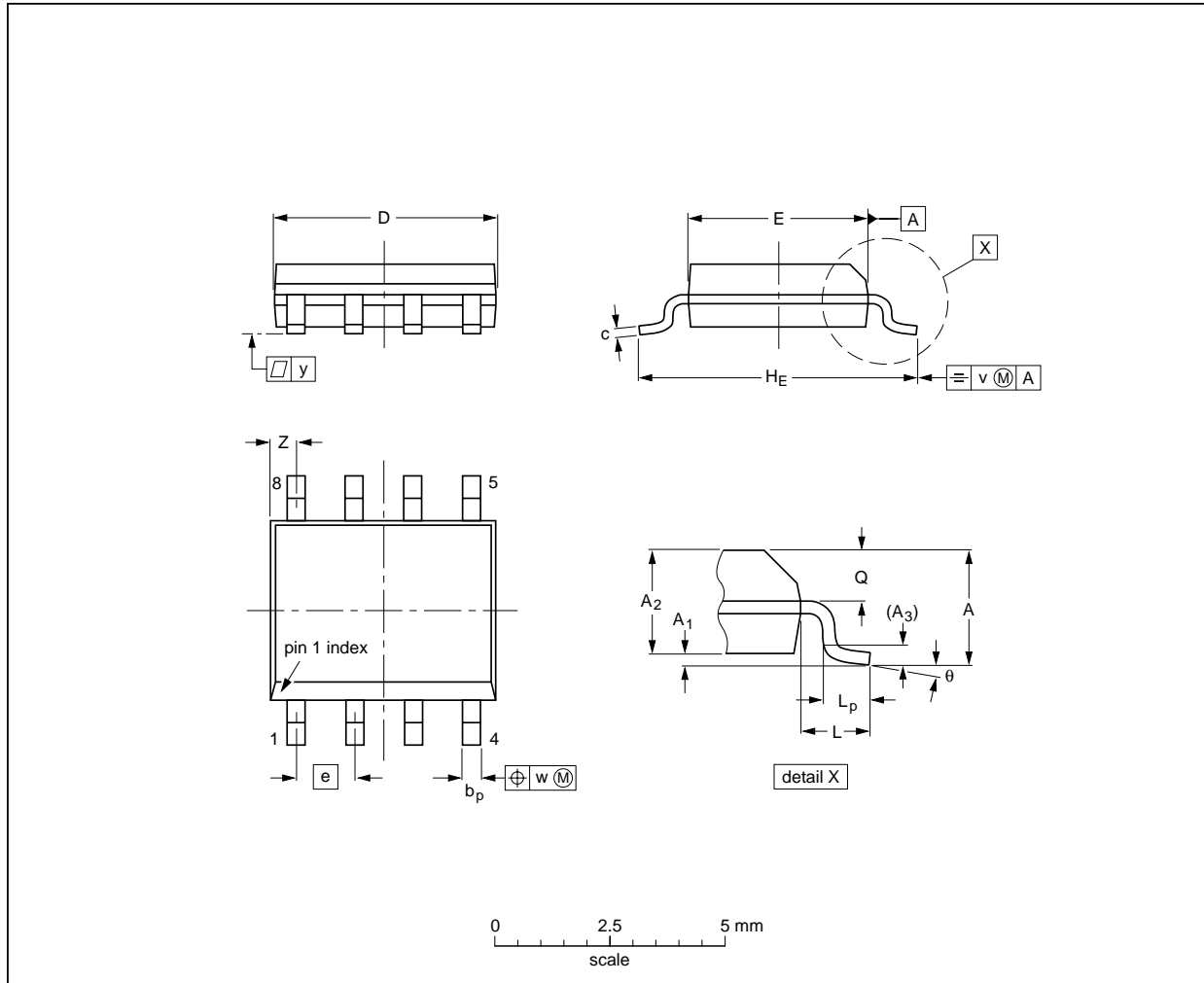

DIMENSIONS (inch dimensions are derived from the original mm dimensions)

UNIT	A max.	A ₁	A ₂	A ₃	b _p	c	D ⁽¹⁾	E ⁽²⁾	e	H _E	L	L _p	Q	v	w	y	Z ⁽¹⁾	θ
mm	1.75	0.25 0.10	1.45 1.25	0.25	0.49 0.36	0.25 0.19	5.0 4.8	4.0 3.8	1.27	6.2 5.8	1.05	1.0 0.4	0.7 0.6	0.25	0.25	0.1	0.7 0.3	8° 0°
inches	0.069	0.010 0.004	0.057 0.049	0.01	0.019 0.014	0.0100 0.0075	0.20 0.19	0.16 0.15	0.050	0.244 0.228	0.041	0.039 0.016	0.028 0.024	0.01	0.01	0.004	0.028 0.012	

Notes

1. Plastic or metal protrusions of 0.15 mm maximum per side are not included.
2. Plastic or metal protrusions of 0.25 mm maximum per side are not included.

OUTLINE VERSION	REFERENCES				EUROPEAN PROJECTION	ISSUE DATE
	IEC	JEDEC	EIAJ			
SOT96-1	076E03S	MS-012AA				95-02-04 97-05-22

Cost effective battery monitor and fast charge IC for NiCd and NiMH chargers

TEA1104; TEA1104T

DIP8: plastic dual in-line package; 8 leads (300 mil)

SOT97-1

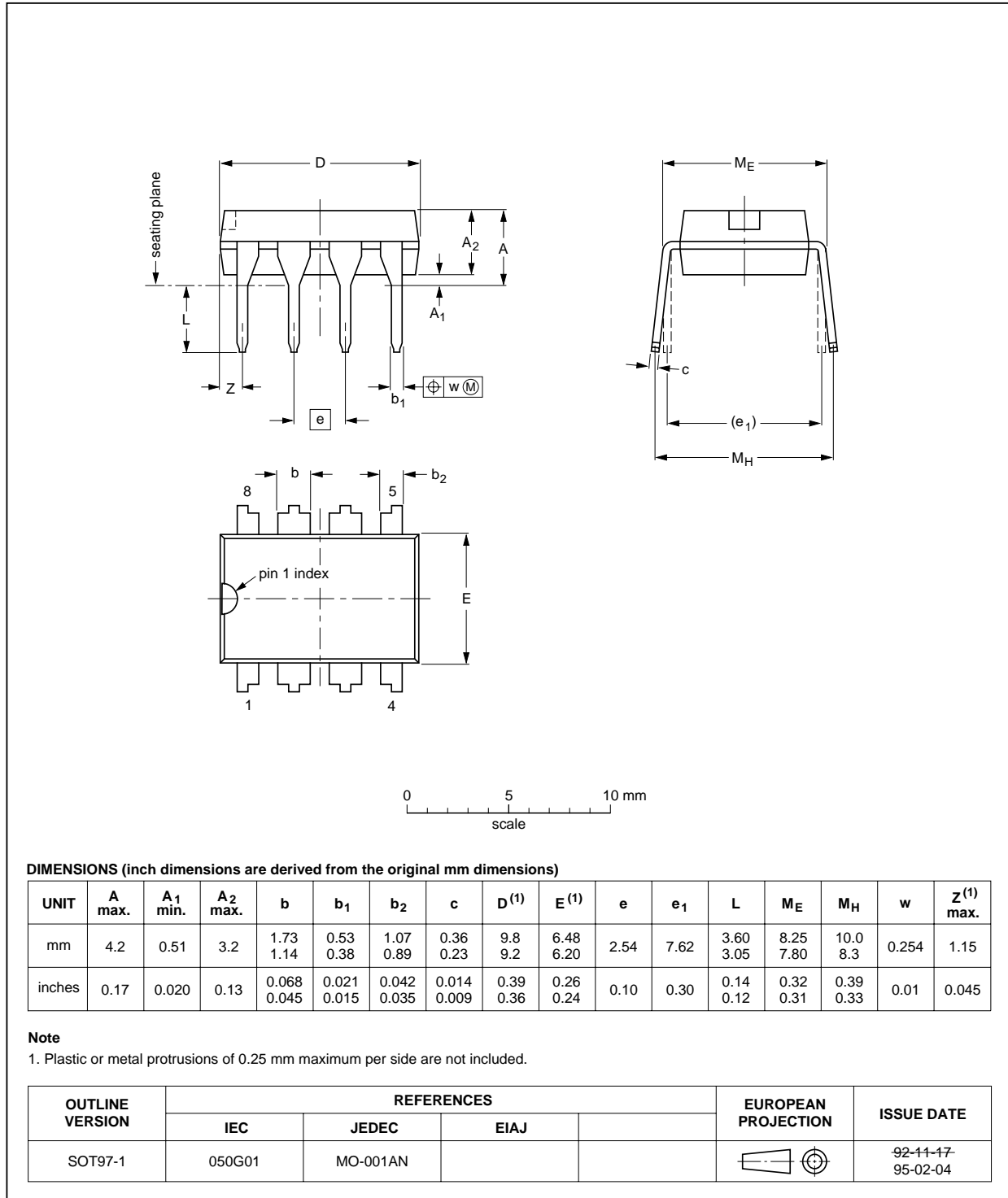

Cost effective battery monitor and fast charge IC for NiCd and NiMH chargers

TEA1104; TEA1104T

SOLDERING

Introduction

There is no soldering method that is ideal for all IC packages. Wave soldering is often preferred when through-hole and surface mounted components are mixed on one printed-circuit board. However, wave soldering is not always suitable for surface mounted ICs, or for printed-circuits with high population densities. In these situations reflow soldering is often used.

This text gives a very brief insight to a complex technology. A more in-depth account of soldering ICs can be found in our *"IC Package Databook"* (order code 9398 652 90011).

DIP

SOLDERING BY DIPPING OR BY WAVE

The maximum permissible temperature of the solder is 260 °C; solder at this temperature must not be in contact with the joint for more than 5 seconds. The total contact time of successive solder waves must not exceed 5 seconds.

The device may be mounted up to the seating plane, but the temperature of the plastic body must not exceed the specified maximum storage temperature ($T_{stg\ max}$). If the printed-circuit board has been pre-heated, forced cooling may be necessary immediately after soldering to keep the temperature within the permissible limit.

REPAIRING SOLDERED JOINTS

Apply a low voltage soldering iron (less than 24 V) to the lead(s) of the package, below the seating plane or not more than 2 mm above it. If the temperature of the soldering iron bit is less than 300 °C it may remain in contact for up to 10 seconds. If the bit temperature is between 300 and 400 °C, contact may be up to 5 seconds.

SO

REFLOW SOLDERING

Reflow soldering techniques are suitable for all SO packages.

Reflow soldering requires solder paste (a suspension of fine solder particles, flux and binding agent) to be applied to the printed-circuit board by screen printing, stencilling or pressure-syringe dispensing before package placement.

Several techniques exist for reflowing; for example, thermal conduction by heated belt. Dwell times vary between 50 and 300 seconds depending on heating method. Typical reflow temperatures range from 215 to 250 °C.

Preheating is necessary to dry the paste and evaporate the binding agent. Preheating duration: 45 minutes at 45 °C.

WAVE SOLDERING

Wave soldering techniques can be used for all SO packages if the following conditions are observed:

- A double-wave (a turbulent wave with high upward pressure followed by a smooth laminar wave) soldering technique should be used.
- The longitudinal axis of the package footprint must be parallel to the solder flow.
- The package footprint must incorporate solder thieves at the downstream end.

During placement and before soldering, the package must be fixed with a droplet of adhesive. The adhesive can be applied by screen printing, pin transfer or syringe dispensing. The package can be soldered after the adhesive is cured.

Maximum permissible solder temperature is 260 °C, and maximum duration of package immersion in solder is 10 seconds, if cooled to less than 150 °C within 6 seconds. Typical dwell time is 4 seconds at 250 °C.

A mildly-activated flux will eliminate the need for removal of corrosive residues in most applications.

REPAIRING SOLDERED JOINTS

Fix the component by first soldering two diagonally-opposite end leads. Use only a low voltage soldering iron (less than 24 V) applied to the flat part of the lead. Contact time must be limited to 10 seconds at up to 300 °C. When using a dedicated tool, all other leads can be soldered in one operation within 2 to 5 seconds between 270 and 320 °C.

Cost effective battery monitor and fast charge IC for NiCd and NiMH chargers

TEA1104; TEA1104T

DEFINITIONS

Data sheet status	
Objective specification	This data sheet contains target or goal specifications for product development.
Preliminary specification	This data sheet contains preliminary data; supplementary data may be published later.
Product specification	This data sheet contains final product specifications.
Limiting values	
Limiting values given are in accordance with the Absolute Maximum Rating System (IEC 134). Stress above one or more of the limiting values may cause permanent damage to the device. These are stress ratings only and operation of the device at these or at any other conditions above those given in the Characteristics sections of the specification is not implied. Exposure to limiting values for extended periods may affect device reliability.	
Application information	
Where application information is given, it is advisory and does not form part of the specification.	

LIFE SUPPORT APPLICATIONS

These products are not designed for use in life support appliances, devices, or systems where malfunction of these products can reasonably be expected to result in personal injury. Philips customers using or selling these products for use in such applications do so at their own risk and agree to fully indemnify Philips for any damages resulting from such improper use or sale.

Philips Semiconductors – a worldwide company

Argentina: IEROD, Av. Juramento 1992 - 14.b, (1428)
BUENOS AIRES, Tel. (541)786 7633, Fax. (541)786 9367

Australia: 34 Waterloo Road, NORTH RYDE, NSW 2113,
Tel. (02)805 4455, Fax. (02)805 4466

Austria: Triester Str. 64, A-1101 WIEN, P.O. Box 213,
Tel. (01)60 101-1236, Fax. (01)60 101-1211

Belgium: Postbus 90050, 5600 PB EINDHOVEN, The Netherlands,
Tel. (31)40-2783749, Fax. (31)40-2788399

Brazil: Rua do Rocio 220 - 5th floor, Suite 51,
CEP: 04552-903-SÃO PAULO-SP, Brazil,
P.O. Box 7383 (01064-970),
Tel. (011)821-2333, Fax. (011)829-1849

Canada: PHILIPS SEMICONDUCTORS/COMPONENTS:
Tel. (800) 234-7381, Fax. (708) 296-8556

Chile: Av. Santa Maria 0760, SANTIAGO,
Tel. (02)773 816, Fax. (02)777 6730

China/Hong Kong: 501 Hong Kong Industrial Technology Centre,
72 Tat Chee Avenue, Kowloon Tong, HONG KONG,
Tel. (852)2319 7888, Fax. (852)2319 7700

Colombia: IPRELENSO LTDA, Carrera 21 No. 56-17,
77621 BOGOTA, Tel. (571)249 7624/(571)217 4609,
Fax. (571)217 4549

Denmark: Prags Boulevard 80, PB 1919, DK-2300
COPENHAGEN S, Tel. (45)32 88 26 36, Fax. (45)31 57 19 49

Finland: Sinikalliontie 3, FIN-02630 ESPOO,
Tel. (358)0-615 800, Fax. (358)0-61580 920

France: 4 Rue du Port-aux-Vins, BP317,
92156 SURESNES Cedex,
Tel. (01)4099 6161, Fax. (01)4099 6427

Germany: P.O. Box 10 51 40, 20035 HAMBURG,
Tel. (040)23 53 60, Fax. (040)23 53 63 00

Greece: No. 15, 25th March Street, GR 17778 TAVROS,
Tel. (01)4894 339/4894 911, Fax. (01)4814 240

India: Philips INDIA Ltd, Shivsagar Estate, A Block,
Dr. Annie Besant Rd. Worli, Bombay 400 018
Tel. (022)4938 541, Fax. (022)4938 722

Indonesia: Philips House, Jalan H.R. Rasuna Said Kav. 3-4,
P.O. Box 4252, JAKARTA 12950,
Tel. (021)5201 122, Fax. (021)5205 189

Ireland: Newstead, Clonskeagh, DUBLIN 14,
Tel. (01)7640 000, Fax. (01)7640 200

Italy: PHILIPS SEMICONDUCTORS S.r.l.,
Piazza IV Novembre 3, 20124 MILANO,
Tel. (0039)2 6752 2531, Fax. (0039)2 6752 2557

Japan: Philips Bldg 13-37, Kohnan2-chome, Minato-ku, TOKYO 108,
Tel. (03)3740 5130, Fax. (03)3740 5077

Korea: Philips House, 260-199 Itaewon-dong,
Yongsan-ku, SEOUL, Tel. (02)709-1412, Fax. (02)709-1415

Malaysia: No. 76 Jalan Universiti, 46200 PETALING JAYA,
SELANGOR, Tel. (03)750 5214, Fax. (03)757 4880

Mexico: 5900 Gateway East, Suite 200, EL PASO, TX 79905,
Tel. 9-5(800)234-7381, Fax. (708)296-8556

Netherlands: Postbus 90050, 5600 PB EINDHOVEN, Bldg. VB,
Tel. (040)2783749, Fax. (040)2788399

New Zealand: 2 Wagener Place, C.P.O. Box 1041, AUCKLAND,
Tel. (09)849-4160, Fax. (09)849-7811

Norway: Box 1, Manglerud 0612, OSLO,
Tel. (022)74 8000, Fax. (022)74 8341

Pakistan: Philips Electrical Industries of Pakistan Ltd.,
Exchange Bldg. ST-2/A, Block 9, KDA Scheme 5, Clifton,
KARACHI 75600, Tel. (021)587 4641-49,
Fax. (021)577035/5874546

Philippines: PHILIPS SEMICONDUCTORS PHILIPPINES Inc.,
106 Valero St. Salcedo Village, P.O. Box 2108 MCC, MAKATI,
Metro MANILA, Tel. (63) 2 816 6380, Fax. (63) 2 817 3474

Portugal: PHILIPS PORTUGUESA, S.A.,
Rua dr. António Loureiro Borges 5, Arquiparque - Miraflores,
Apartado 300, 2795 LINDA-A-VELHA,
Tel. (01)4163160/4163333, Fax. (01)4163174/4163366

Singapore: Lorong 1, Toa Payoh, SINGAPORE 1231,
Tel. (65)350 2000, Fax. (65)251 6500

South Africa: S.A. PHILIPS Pty Ltd.,
195-215 Main Road Martindale, 2092 JOHANNESBURG,
P.O. Box 7430, Johannesburg 2000,
Tel. (011)470-5911, Fax. (011)470-5494

Spain: Balmes 22, 08007 BARCELONA,
Tel. (03)301 6312, Fax. (03)301 42 43

Sweden: Kottbygatan 7, Akalla. S-164 85 STOCKHOLM,
Tel. (0)8-632 2000, Fax. (0)8-632 2745

Switzerland: Allmendstrasse 140, CH-8027 ZÜRICH,
Tel. (01)488 2211, Fax. (01)481 77 30

Taiwan: PHILIPS TAIWAN Ltd., 23-30F, 66, Chung Hsiao West
Road, Sec. 1. Taipei, Taiwan ROC, P.O. Box 22978,
TAIPEI 100, Tel. (886) 2 382 4443, Fax. (886) 2 382 4444

Thailand: PHILIPS ELECTRONICS (THAILAND) Ltd.,
209/2 Sanpavuth-Bangna Road Prakanong,
Bangkok 10260, THAILAND,
Tel. (66) 2 745-4090, Fax. (66) 2 398-0793

Turkey: Talatpasa Cad. No. 5, 80640 GÜLTEPE/ISTANBUL,
Tel. (0212)279 27 70, Fax. (0212)282 67 07

Ukraine: Philips UKRAINE, 2A Akademika Koroleva str., Office 165,
252148 KIEV, Tel. 380-44-4760297, Fax. 380-44-4766991

United Kingdom: Philips Semiconductors LTD.,
276 Bath Road, Hayes, MIDDLESEX UB3 5BX,
Tel. (0181)730-5000, Fax. (0181)754-8421

United States: 811 East Arques Avenue, SUNNYVALE,
CA 94088-3409, Tel. (800)234-7381, Fax. (708)296-8556

Uruguay: Coronel Mora 433, MONTEVIDEO,
Tel. (02)70-4044, Fax. (02)92 0601

Internet: <http://www.semiconductors.philips.com/ps/>

For all other countries apply to: Philips Semiconductors,
International Marketing and Sales, Building BE-p,
P.O. Box 218, 5600 MD EINDHOVEN, The Netherlands,
Telex 35000 phtnl, Fax. +31-40-2724825

SCDS47

© Philips Electronics N.V. 1996

All rights are reserved. Reproduction in whole or in part is prohibited without the prior written consent of the copyright owner.

The information presented in this document does not form part of any quotation or contract, is believed to be accurate and reliable and may be changed without notice. No liability will be accepted by the publisher for any consequence of its use. Publication thereof does not convey nor imply any license under patent- or other industrial or intellectual property rights.

Printed in The Netherlands

417021/1100/02/pp16
Document order number:

Date of release: 1996 Feb 26
9397 750 00692