



TSH80-TSH81-TSH82

WIDE BAND, RAIL to RAIL OPERATIONAL AMPLIFIER WITH STANDBY FUNCTION

- **4.5V, 12V OPERATING CONDITIONS**
- **3dB-BANDWIDTH: 100MHz**
- **SLEW-RATE: 100V/μs**
- **OUTPUT CURRENT: up to 55mA**
- **INPUT SINGLE SUPPLY VOLTAGE**
- **OUTPUT RAIL TO RAIL**
- **SPECIFIED FOR 150Ω LOAD**
- **LOW DISTORTION, THD: 0.1%**
- **SOT23-5, TSSOP and SO PACKAGES**

DESCRIPTION

The TSH8x serie offers Single and Dual operational amplifiers featuring high video performances with large bandwidth, low distortion and excellent supply voltage rejection. These amplifiers feature also large output voltage swing and high output current capability to drive standard 150Ω loads.

Running at single or dual supply voltage from 4.5V to 12V, these amplifiers are tested at 5V(±2.5V) and 10V(±5V) supplies.

The TSH81 also features a Standby mode, which allows the operational amplifier to be put into a standby mode with low power consumption and high output impedance. The function allows power saving or signals switching/multiplexing for high speed applications and video applications.

For board space and weight saving, TSH8x series is proposed in SOT23-5, TSSOP8 and SO8 packages.

APPLICATION

- **Video Buffers**
- **A/D Converters Driver**
- **Hi-Fi Applications**

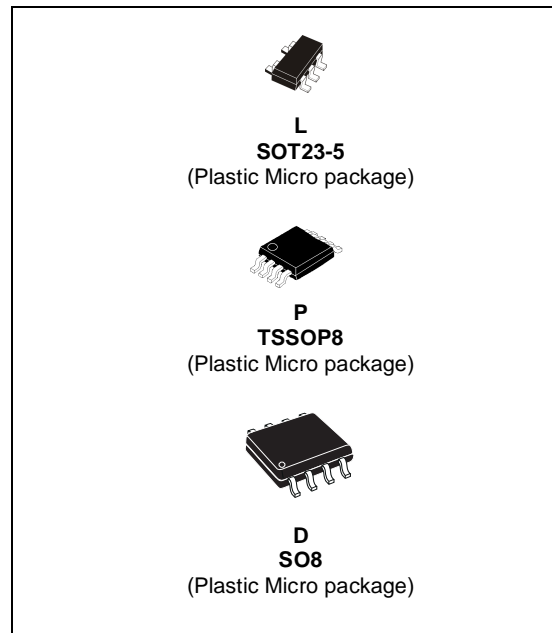

PIN CONNECTIONS (top view)

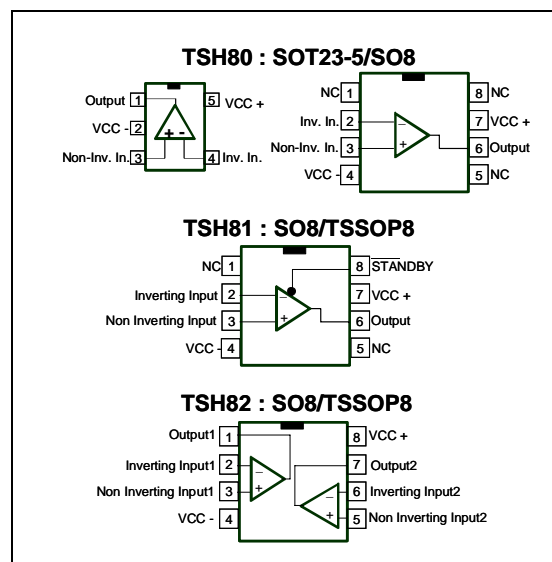

TSH80-TSH81-TSH82

ABSOLUTE MAXIMUM RATINGS

Symbol	Parameter	Value	Unit
V_{CC}	Supply Voltage ¹⁾	14	V
V_{id}	Differential Input Voltage ²⁾	± 2	V
V_i	Input Voltage ³⁾	± 6	V
T_{oper}	Operating Free Air Temperature Range	-40 to +85	°C
T_{stg}	Storage Temperature	-65 to +150	°C
T_j	Maximum Junction Temperature	150	°C
R_{thjc}	Thermal resistance junction to case ⁴⁾		
	SOT23-5	80	°C/W
	SO8	28	
TSSOP8	37		
R_{thja}	Thermal resistance junction to ambient area		
	SOT23-5	250	°C/W
	SO8	157	
TSSOP8	130		
ESD	Human Body Model	2	kV

1. All voltage values, except differential voltage are with respect to network ground terminal
2. Differential voltages are non-inverting input terminal with respect to the inverting terminal
3. The magnitude of input and output must never exceed $V_{CC} + 0.3V$
4. Short-circuits can cause excessive heating

OPERATING CONDITIONS

Symbol	Parameter	Value	Unit
V_{CC}	Supply Voltage	4.5 to 12	V
V_{IC}	Common Mode Input Voltage Range	V_{CC}^- to $(V_{CC}^+ - 1.1)$	V
Standby		(V_{CC}^-) to (V_{CC}^+)	V

ORDER CODES

Type	Temperature	Package	Marking
TSH80ILT	-40°C to +85°C	SOT23-5	K303
TSH80ID	-40°C to +85°C	SO8	TSH80I
TSH80IDT	-40°C to +85°C	SO8 Tape	TSH80I
TSH81ID	-40°C to +85°C	SO8	TSH81I
TSH81IDT	-40°C to +85°C	SO8 Tape	TSH81I
TSH81IPT	-40°C to +85°C	TSSOP8	TSH81I
TSH82ID	-40°C to +85°C	SO8	TSH82I
TSH82IDT	-40°C to +85°C	SO8 Tape	TSH82I
TSH82IPT	-40°C to +85°C	TSSOP8	TSH82I

- I = Temperature range
D = Small Outline Package (SO) - also available in Tape & Reel (DT)
P = Thin Shrink Small Outline Package (TSSOP) - only available in Tape & Reel (PT)
L = Tiny Package (SOT23-5) - only available in Tape & Reel (LT)

ELECTRICAL CHARACTERISTICS
 $V_{CC}^+ = +5V$, $V_{CC}^- = GND$, $V_{ic} = 2.5V$, $T_{amb} = 25^\circ C$ (unless otherwise specified)

Symbol	Parameter	Test Condition	Min.	Typ.	Max.	Unit
$ V_{io} $	Input Offset Voltage	$T_{amb} = 25^\circ C$ $T_{min.} < T_{amb} < T_{max.}$		1.1	10 12	mV
ΔV_{io}	Input Offset Voltage Drift vs Temperature	$T_{min.} < T_{amb} < T_{max.}$		3		$\mu V/^\circ C$
I_{io}	Input Offset Current	$T_{amb} = 25^\circ C$ $T_{min.} < T_{amb} < T_{max.}$		0.1	3.5 5	μA
I_{ib}	Input Bias Current	$T_{amb} = 25^\circ C$ $T_{min.} < T_{amb} < T_{max.}$		6	15 20	μA
C_{in}	Input Capacitance			0.3		pF
I_{CC}	Supply Current per Operator	$T_{amb} = 25^\circ C$ $T_{min.} < T_{amb} < T_{max.}$		8.2	10.5 11.5	mA
CMR	Common Mode Rejection Ratio ($\delta V_{ic}/\delta V_{io}$)	$+0.1 < V_{ic} < 3.9V$ & $V_{out}=2.5V$ $T_{amb} = 25^\circ C$ $T_{min.} < T_{amb} < T_{max.}$	72 70	97		dB
SVR	Supply Voltage Rejection Ratio ($\delta V_{CC}/\delta V_{io}$)	$T_{amb} = 25^\circ C$ $T_{min.} < T_{amb} < T_{max.}$	68 65	75		dB
PSR	Power Supply Rejection Ratio ($\delta V_{CC}/\delta V_{out}$)	Positive & Negative Rail		75		dB
A_{vd}	Large Signal Voltage Gain	$R_L = 150\Omega$ to 1.5V $V_{out}=1V$ to 4V $T_{amb} = 25^\circ C$ $T_{min.} < T_{amb} < T_{max.}$	75 70	84		dB
I_o	Output Short Circuit Current Source	$T_{amb}=25^\circ C$ $V_{id}=+1, V_{out}$ to 1.5V $V_{id}=-1, V_{out}$ to 1.5V Source Sink $T_{min.} < T_{amb} < T_{max.}$ $V_{id}=+1, V_{out}$ to 1.5V $V_{id}=-1, V_{out}$ to 1.5V Source Sink	35 33 28 28	55 55		mA
V_{oh}	High Level Output Voltage	$T_{amb}=25^\circ C$ $R_L = 150\Omega$ to GND $R_L = 600\Omega$ to GND $R_L = 2k\Omega$ to GND $R_L = 10k\Omega$ to GND $R_L = 150\Omega$ to 2.5V $R_L = 600\Omega$ to 2.5V $R_L = 2k\Omega$ to 2.5V $R_L = 10k\Omega$ to 2.5V $T_{min.} < T_{amb} < T_{max.}$ $R_L = 150\Omega$ to GND $R_L = 150\Omega$ to 2.5V	4.2 4.1 4.4	4.36 4.85 4.90 4.93 4.66 4.90 4.92 4.93		V

TSH80-TSH81-TSH82

Symbol	Parameter	Test Condition	Min.	Typ.	Max.	Unit
V_{ol}	Low Level Output Voltage	$T_{amb}=25^{\circ}C$ $R_L = 150\Omega$ to GND $R_L = 600\Omega$ to GND $R_L = 2k\Omega$ to GND $R_L = 10k\Omega$ to GND $R_L = 150\Omega$ to 2.5V $R_L = 600\Omega$ to 2.5V $R_L = 2k\Omega$ to 2.5V $R_L = 10k\Omega$ to 2.5V $T_{min.} < T_{amb} < T_{max.}$ $R_L = 150\Omega$ to GND $R_L = 150\Omega$ to 2.5V		48 54 55 56 220 105 76 61	150 200 450	mV
GBP	Gain Bandwidth Product	$F=10MHz$ $A_{VCL}=+11$ $A_{VCL}=-10$		65 55		MHz
Bw	Bandwidth @-3dB	$A_{VCL}=+1$ $R_L=150\Omega$ to 2.5V		87		MHz
SR	Slew Rate	$A_{VCL}=+2$ $R_L=150\Omega // C_L$ to 2.5V $C_L = 5pF$ $C_L = 30pF$	60	104 105		V/ μs
ϕ_m	Phase Margin	$R_L=150\Omega // 30pF$ to 2.5V		40		$^{\circ}$
e_n	Equivalent Input Noise Voltage	$F=100kHz$		11		nV/ \sqrt{Hz}
THD	Total Harmonic Distortion	$A_{VCL}=+2, F=4MHz$ $R_L=150\Omega // 30pF$ to 2.5V $V_{out}=1V_{pp}$ $V_{out}=2V_{pp}$		-61 -54		dB
IM2	Second order inter modulation product	$A_{VCL}=+2, V_{out}=2V_{pp}$ $R_L=150\Omega$ to 2.5V $F_{in1}=180kHz, F_{in2}=280kHz$ spurious measurement @ 100kHz		-76		dBc
IM3	Third order inter modulation product	$A_{VCL}=+2, V_{out}=2V_{pp}$ $R_L=150\Omega$ to 2.5V $F_{in1}=180kHz, F_{in2}=280kHz$ spurious measurement @ 400kHz		-68		dBc
ΔG	Differential gain	$A_{VCL}=+2, R_L=150\Omega$ to 2.5V $F=4.5MHz, V_{out}=2V_{pp}$		0.5		%
Df	Differential phase	$A_{VCL}=+2, R_L=150\Omega$ to 2.5V $F=4.5MHz, V_{out}=2V_{pp}$		0.5		$^{\circ}$
Gf	Gain Flatness	$F=DC$ to 6MHz, $A_{VCL}=+2$		0.2		dB
V_{o1}/V_{o2}	Channel Separation	$F=1MHz$ to 10MHz		65		dB

ELECTRICAL CHARACTERISTICS
 $V_{CC}^+ = +5V$, $V_{CC}^- = -5V$, $V_{ic} = GND$, $T_{amb} = 25^\circ C$ (unless otherwise specified)

Symbol	Parameter	Test Condition	Min.	Typ.	Max.	Unit
$ V_{io} $	Input Offset Voltage	$T_{amb} = 25^\circ C$ $T_{min.} < T_{amb} < T_{max.}$		0.8	10 12	mV
ΔV_{io}	Input Offset Voltage Drift vs Temperature	$T_{min.} < T_{amb} < T_{max.}$		2		$\mu V/^\circ C$
I_{io}	Input Offset Current	$T_{amb} = 25^\circ C$ $T_{min.} < T_{amb} < T_{max.}$		0.1	3.5 5	μA
I_{ib}	Input Bias Current	$T_{amb} = 25^\circ C$ $T_{min.} < T_{amb} < T_{max.}$		6	15 20	μA
C_{in}	Input Capacitance			0.7		pF
I_{CC}	Supply Current per Operator	$T_{amb} = 25^\circ C$ $T_{min.} < T_{amb} < T_{max.}$		9.8	12.3 13.4	mA
CMR	Common Mode Rejection Ratio ($\delta V_{ic}/\delta V_{io}$)	-4.9< V_{ic} <3.9V & $V_{out}=GND$ $T_{amb} = 25^\circ C$ $T_{min.} < T_{amb} < T_{max.}$	81 72	106		dB
SVR	Supply Voltage Rejection Ratio ($\delta V_{CC}/\delta V_{io}$)	$T_{amb} = 25^\circ C$ $T_{min.} < T_{amb} < T_{max.}$	71 65	77		dB
PSR	Power Supply Rejection Ratio ($\delta V_{CC}/\delta V_{out}$)	Positive & Negative Rail		75		dB
A_{vd}	Large Signal Voltage Gain	$R_L = 150\Omega$ to GND $V_{out} = -4$ to $+4$ $T_{amb} = 25^\circ C$ $T_{min.} < T_{amb} < T_{max.}$	75 70	86		dB
I_o	Output Short Circuit Current Source	$T_{amb} = 25^\circ C$ $V_{id} = +1$, V_{out} to 1.5V $V_{id} = -1$, V_{out} to 1.5V Source Sink $T_{min.} < T_{amb} < T_{max.}$ $V_{id} = +1$, V_{out} to 1.5V $V_{id} = -1$, V_{out} to 1.5V Source Sink	35 30 28 28	55 55		mA
V_{oh}	High Level Output Voltage	$T_{amb} = 25^\circ C$ $R_L = 150\Omega$ to GND $R_L = 600\Omega$ to GND $R_L = 2k\Omega$ to GND $R_L = 10k\Omega$ to GND $T_{min.} < T_{amb} < T_{max.}$ $R_L = 150\Omega$ to GND	4.2 4.1	4.36 4.85 4.9 4.93		V
V_{ol}	Low Level Output Voltage	$T_{amb} = 25^\circ C$ $R_L = 150\Omega$ to GND $R_L = 600\Omega$ to GND $R_L = 2k\Omega$ to GND $R_L = 10k\Omega$ to GND $T_{min.} < T_{amb} < T_{max.}$ $R_L = 150\Omega$ to GND		-4.63 -4.86 -4.9 -4.93	-4.4 -4.3	mV
GBP	Gain Bandwidth Product	F=10MHz $A_{VCL} = +11$ $A_{VCL} = -10$		65 55		MHz
Bw	Bandwidth @-3dB	$A_{VCL} = +1$ $R_L = 150\Omega // 30pF$ to GND		100		MHz

TSH80-TSH81-TSH82

Symbol	Parameter	Test Condition	Min.	Typ.	Max.	Unit
SR	Slew Rate	$A_{VCL}=+2$ $R_L=150\Omega // C_L$ to GND $C_L = 5pF$ $C_L = 30pF$	68	117 118		V/ μ s
ϕ_m	Phase Margin	$R_L=150\Omega$ to gnd		40		°
en	Equivalent Input Noise Voltage	F=100kHz		11		nV/ \sqrt{Hz}
THD	Total Harmonic Distortion	$A_{VCL}=+2$, F=4MHz $R_L=150\Omega // 30pF$ to gnd $V_{out}=1V_{pp}$ $V_{out}=2V_{pp}$		-61 -54		dB
IM2	Second order inter modulation product	$A_{VCL}=+2$, $V_{out}=2V_{pp}$ $R_L=150\Omega$ to gnd Fin1=180kHz, Fin2=280KHz spurious measurement @100kHz		-76		dBc
IM3	Third order inter modulation product	$A_{VCL}=+2$, $V_{out}=2V_{pp}$ $R_L=150\Omega$ to gnd Fin1=180kHz, Fin2=280KHz spurious measurement @400kHz		-68		dBc
ΔG	Differential gain	$A_{VCL}=+2$, $R_L=150\Omega$ to gnd F=4.5MHz, $V_{out}=2V_{pp}$		0.5		%
Df	Differential phase	$A_{VCL}=+2$, $R_L=150\Omega$ to gnd F=4.5MHz, $V_{out}=2V_{pp}$		0.5		°
Gf	Gain Flatness	F=DC to 6MHz, $A_{VCL}=+2$		0.2		dB
Vo1/Vo2	Channel Separation	F=1MHz to 10MHz		65		dB

STANDBY MODE V_{CC}^+ , V_{CC}^- , $T_{amb} = 25^\circ\text{C}$ (unless otherwise specified)

Symbol	Parameter	Test Condition	Min.	Typ.	Max.	Unit
V_{low}	Standby Low Level		V_{CC}^-		$(V_{CC}^- + 0.8)$	V
V_{high}	Standby High Level		$(V_{CC}^- + 2)$		(V_{CC}^+)	V
$I_{CC\ SBY}$	Current Consumption per Operator when STANDBY is Active	pin 8 (TSH81) to V_{CC}^-		20	55	μA
Z_{out}	Output Impedance (R_{out}/C_{out})	R_{out} C_{out}		10 17		$\text{M}\Omega$ pF
T_{on}	Time from Standby Mode to Active Mode			2		μs
T_{off}	Time from Active Mode to Standby Mode	Down to $I_{CC\ SBY} = 10\mu\text{A}$		10		μs

TSH81 STANDBY CONTROL pin 8 ($\overline{\text{SBY}}$)	OPERATOR STATUS
V_{low}	Standby
V_{high}	Active

Closed Loop Gain and Phase vs. Frequency

Gain=+2, $V_{CC} = \pm 2.5V$, $R_L = 150\Omega$, $T_{amb} = 25^\circ C$

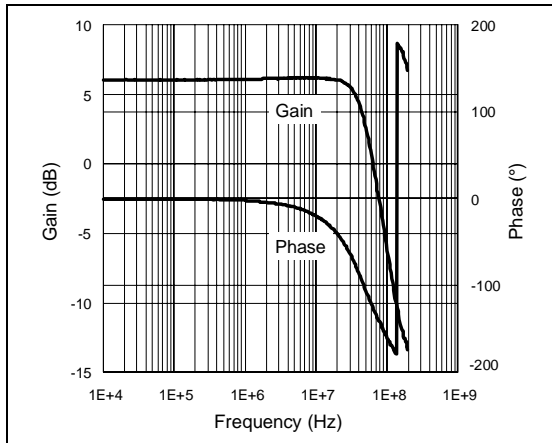

Overshoot function of output capacitance

Gain=+2, $V_{CC} = \pm 2.5V$, $T_{amb} = 25^\circ C$

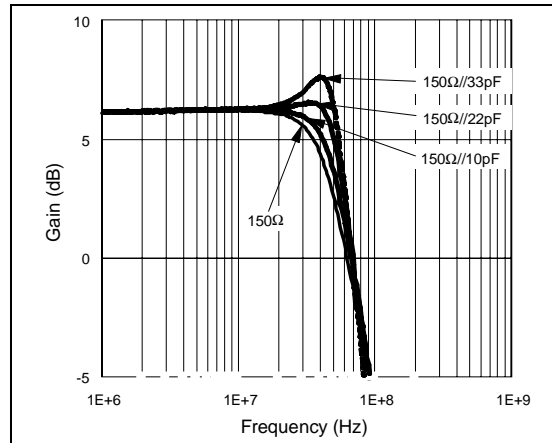

Closed Loop Gain and Phase vs. Frequency

Gain=-10, $V_{CC} = \pm 2.5V$, $R_L = 150\Omega$, $T_{amb} = 25^\circ C$

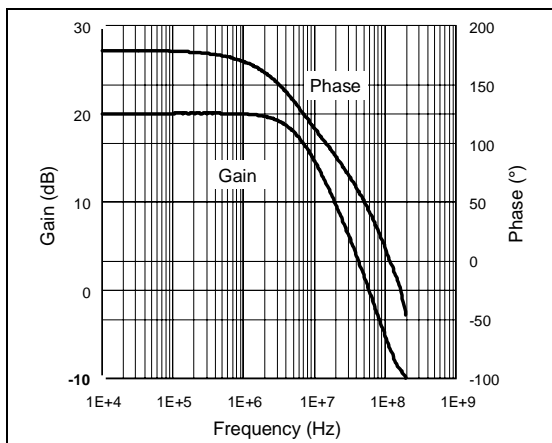

Closed Loop Gain and Phase vs. Frequency

Gain=+11, $V_{CC} = \pm 2.5V$, $R_L = 150\Omega$, $T_{amb} = 25^\circ C$

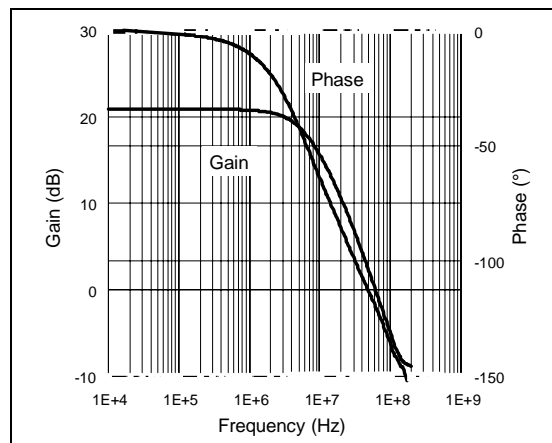

Large Signal Measurement - Positive Slew Rate

Gain=2, $V_{CC} = \pm 2.5V$, $Z_L = 150\Omega // 5.6pF$, $V_{in} = 400mV_{pk}$

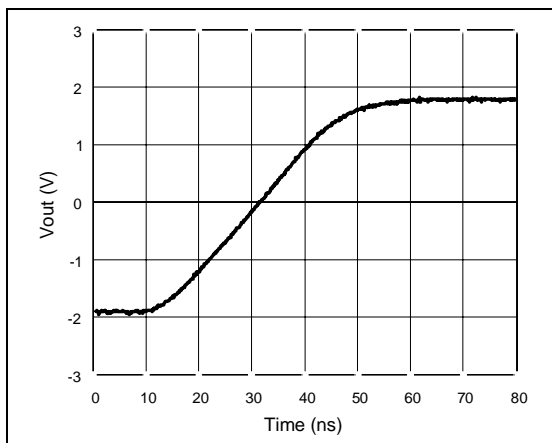

Large Signal Measurement - Negative Slew Rate

Gain=2, $V_{CC} = \pm 2.5V$, $Z_L = 150\Omega // 5.6pF$, $V_{in} = 400mV_{pk}$

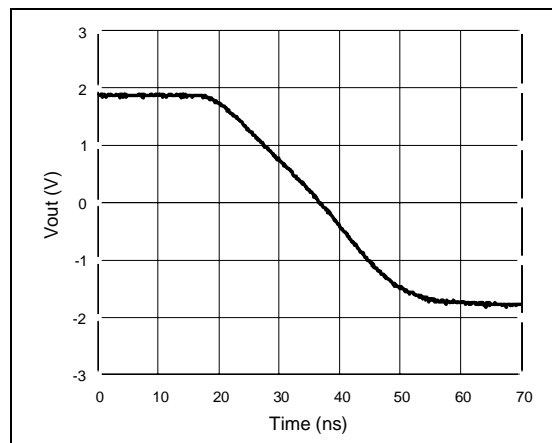

Small Signal Measurement - Rise Time

Gain=2, $V_{cc}=\pm 2.5V$, $Z_L=150\Omega$, $V_{in}=400mV_{pk}$

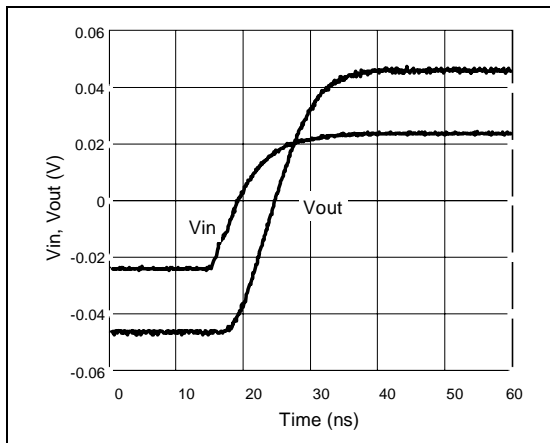

Small Signal Measurement - Fall Time

Gain=2, $V_{cc}=\pm 2.5V$, $Z_L=150\Omega$, $V_{in}=400mV_{pk}$

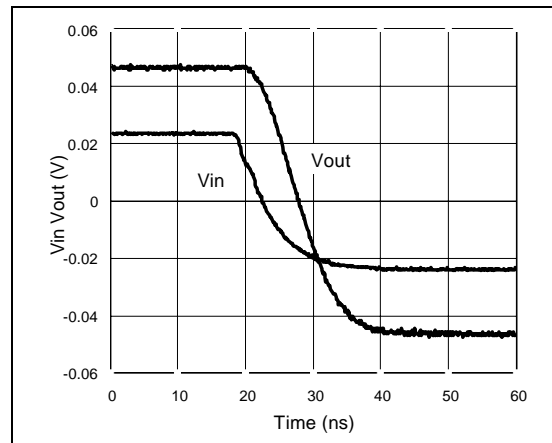

Channel separation (Xtalk) vs frequency

Measurement configuration: $X_{talk}=20\log(V_0/V_1)$

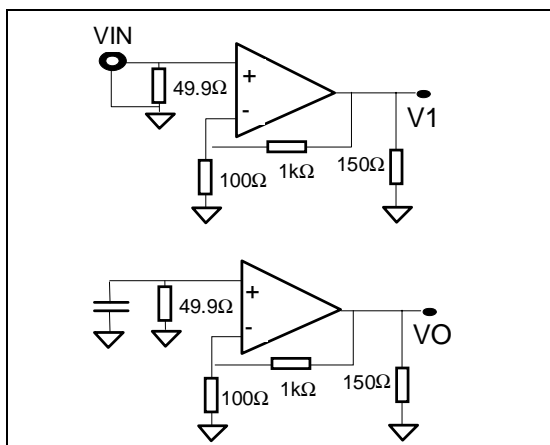

Channel separation (Xtalk) vs frequency

Gain=+11, $V_{cc}=\pm 2.5V$, $Z_L=150\Omega//27pF$

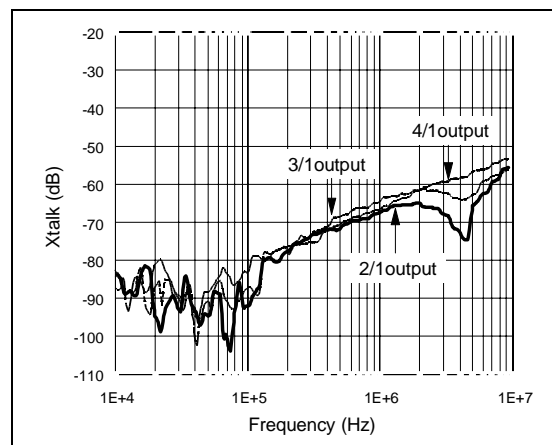

Equivalent Noise Voltage

Gain=100, $V_{cc}=\pm 2.5V$, No load

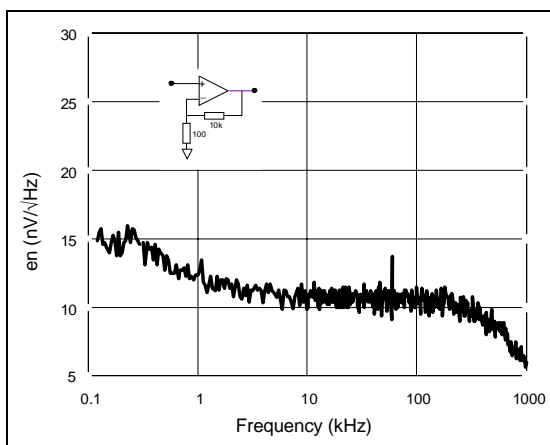

Maximum Output Swing

Gain=11, $V_{cc}=\pm 2.5V$, $R_L=150\Omega$

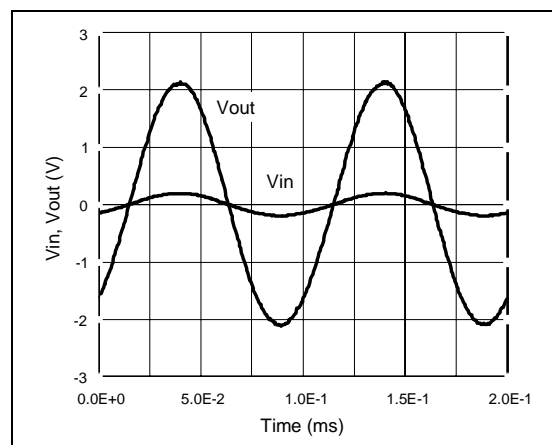

TSH80-TSH81-TSH82

Standby Mode - Ton, Toff

$V_{CC} = \pm 2.5V$, Open Loop

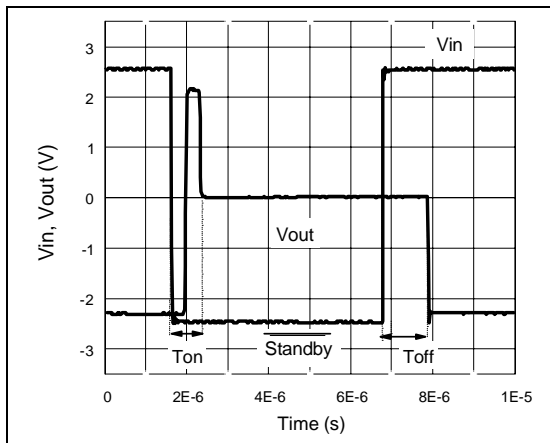

Group Delay

Gain=2, $V_{CC} = \pm 2.5V$, $Z_L = 150\Omega // 27pF$, $T_{amb} = 25^\circ C$

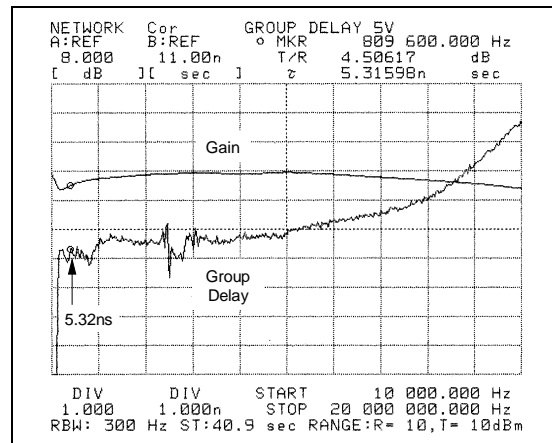

Inter modulation products

The IFR2026 synthesizer generates a two tones signal ($F_1=180kHz$, $F_2=280kHz$); each tone having the same amplitude level.

The HP3585 spectrum analyzer measures the inter modulation products function of the output voltage. The generator and the spectrum analyzer are phase locked for precision considerations.

Third Order Inter modulation

Gain=2, $V_{CC} = \pm 2.5V$, $Z_L = 150\Omega // 27pF$, $T_{amb} = 25^\circ C$

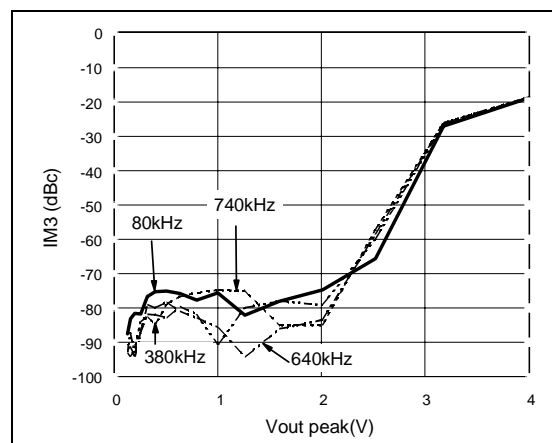

Closed Loop Gain and Phase vs. Frequency
 Gain=+2, Vcc= ±5V, RL=150Ω, T_{amb} = 25 °C

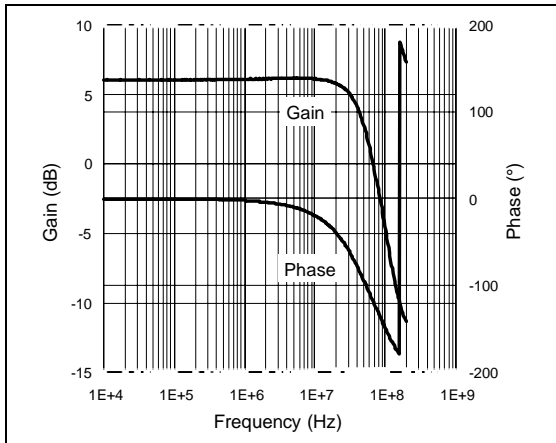

Overshoot function of output capacitance
 Gain=+2, Vcc= ±5V, T_{amb} = 25 °C

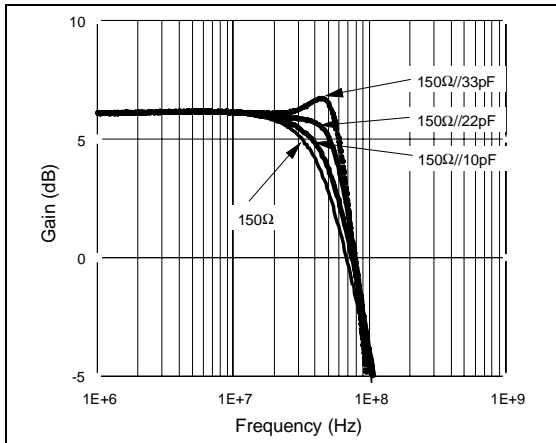

Closed Loop Gain and Phase vs. Frequency
 Gain=-10, Vcc= ±5V, RL=150Ω, T_{amb} = 25 °C

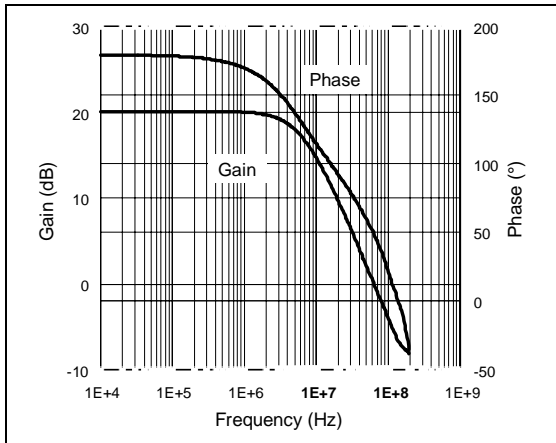

Closed Loop Gain and Phase vs. Frequency
 Gain=+11, Vcc= ±5V, RL=150Ω, T_{amb} = 25 °C

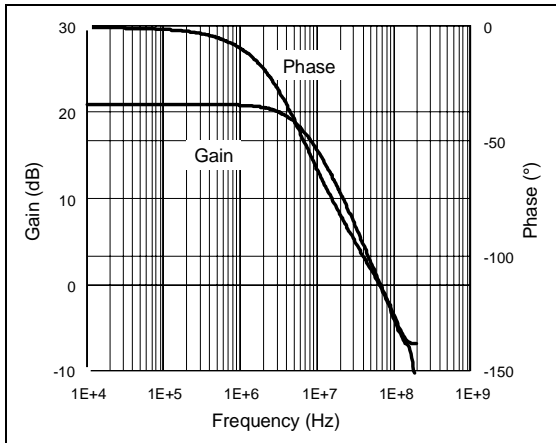

Large Signal Measurement - Positive Slew Rate
 Gain=2, Vcc=±5V, ZL=150Ω//5.6pF, Vin=400mVpk

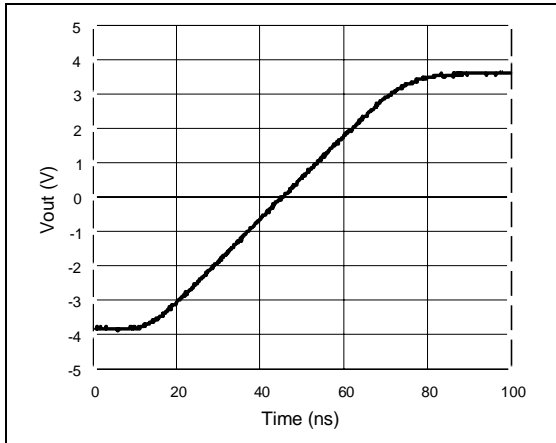

Large Signal Measurement - Negative Slew Rate
 Gain=2, Vcc=±5V, ZL=150Ω//5.6pF, Vin=400mVpk

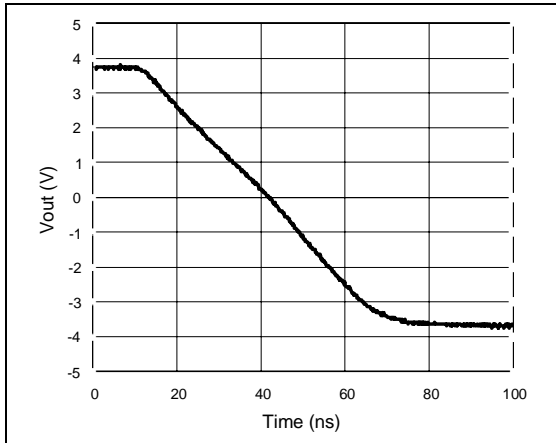

TSH80-TSH81-TSH82

Small Signal Measurement - Rise Time

Gain=2, $V_{cc}=\pm 5V$, $Z_L=150\Omega$, $V_{in}=400mV_{pk}$

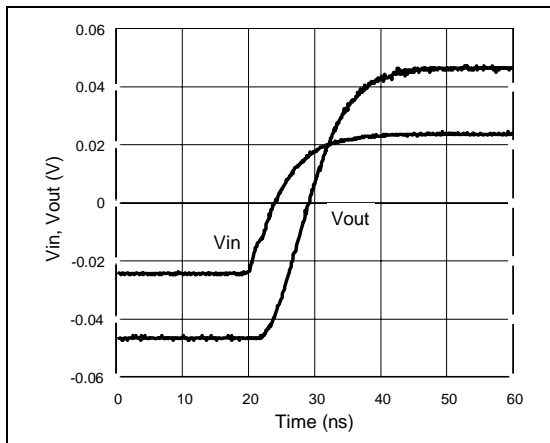

Small Signal Measurement - Fall Time

Gain=2, $V_{cc}=\pm 5V$, $Z_L=150\Omega$, $V_{in}=400mV_{pk}$

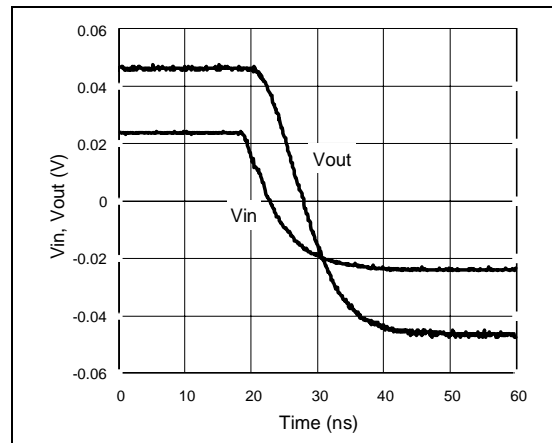

Channel separation (Xtalk) vs frequency

Measurement configuration: $X_{talk}=20\log(V_0/V_1)$

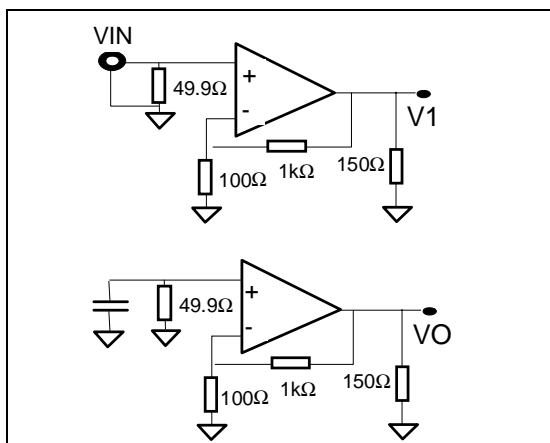

Channel separation (Xtalk) vs frequency

Gain=+11, $V_{cc}=\pm 5V$, $Z_L=150\Omega//27pF$

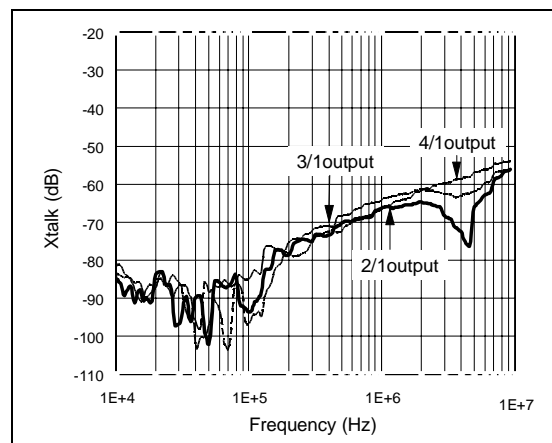

Equivalent Noise Voltage

Gain=100, $V_{cc}=\pm 5V$, No load

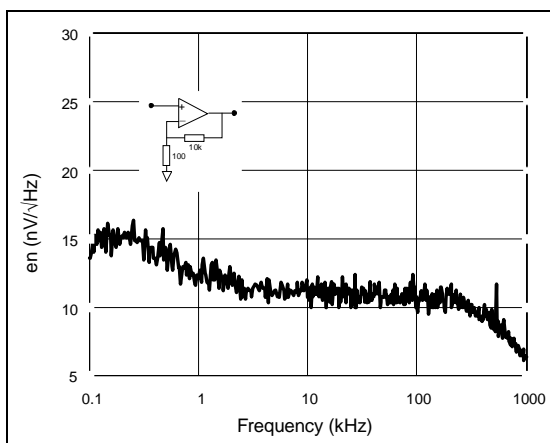

Maximum Output Swing

Gain=11, $V_{cc}=\pm 5V$, $R_L=150\Omega$

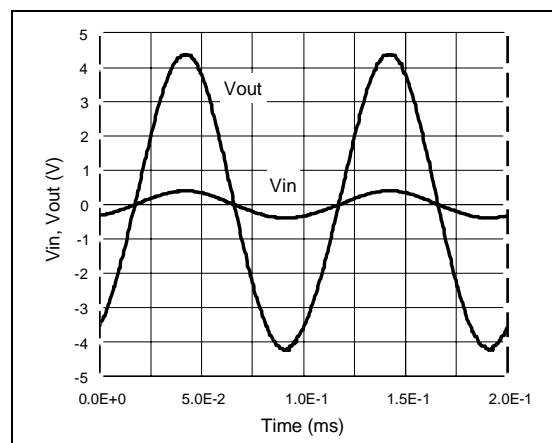

Standby Mode - Ton, Toff

Vcc=±5V, Open Loop

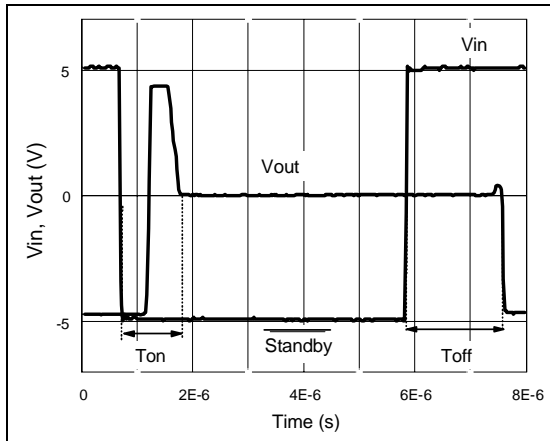

Group Delay

Gain=2, Vcc=±5V, ZL=150Ω//27pF, T_{amb} = 25°C

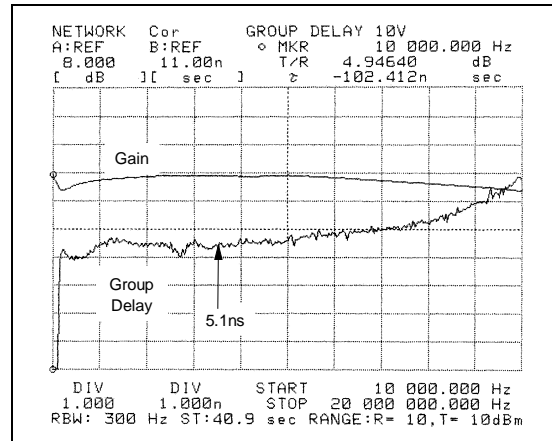

Third Order Inter modulation

Gain=2, Vcc=±5V, ZL=150Ω//27pF, T_{amb} = 25°C

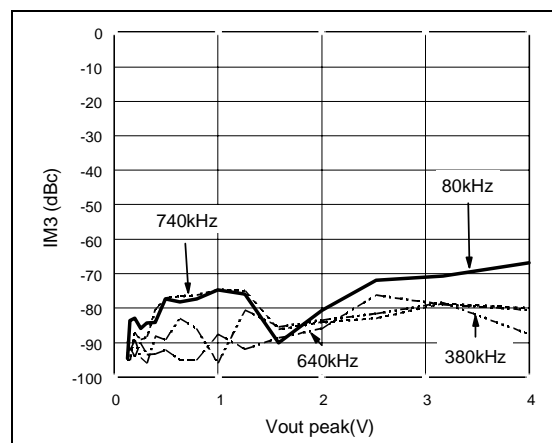

Inter modulation products

The IFR2026 synthesizer generates a two tones signal (F1=180kHz, F2=280kHz); each tone having the same amplitude level.

The HP3585 spectrum analyzer measures the inter modulation products function of the output voltage. The generator and the spectrum analyzer are phase locked for precision considerations.

TESTING CONDITIONS:

Layout precautions:

To use the TSH8X circuits in the best manner at high frequencies, some precautions have to be taken for power supplies:

- First of all, the implementation of a proper ground plane in both sides of the PCB is mandatory for high speed circuit applications to provide low inductance and low resistance common return.

- Power supply bypass capacitors (4.7uF and ceramic 100pF) should be placed as close as possible to the IC pins in order to improve high frequency bypassing and reduce harmonic distortion. The power supply capacitors must be incorporated for both the negative and the positive pins.

- Proper termination of all inputs and outputs must be in accordance with output termination resistors; then the amplifier load will be only resistive and the stability of the amplifier will be improved.

All leads must be wide and as short as possible especially for op amp inputs and outputs in order to decrease parasitic capacitance and inductance.

- For lower gain application, attention should be paid not to use large feedback resistance (>1kΩ) to reduce time constant with parasitic capacitances.

- Choose component sizes as small as possible (SMD).

- Finally, on output, the load capacitance must be negligible to maintain good stability. You can put a serial resistance the closest to the output pin to minimize its influence.

CCIR330 video line

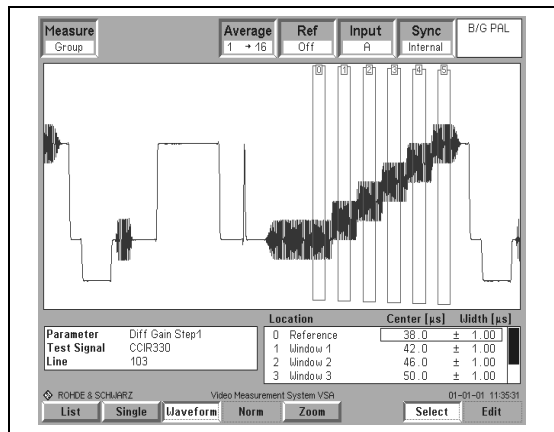

Maximum input level:

The input level must not exceed the following values:

- negative peak: must be greater than $-V_{cc}+400mV$.
- positive peak value: must be lower than $+V_{cc}-400mV$.

The electrical characteristics show the influence of the load on this parameter.

Video capabilities:

To characterize the differential phase and differential gain a CCIR330 video line is used.

The video line contains 5 (flat) levels of luma on which is superimposed chroma signal. (the first level contains no luma). The luma gives various amplitudes which define the saturation of the signal. The chrominance gives various phases which define the colour of the signal.

Differential phase (respectively differential gain) distortion is present if a signal chrominance phase (gain) is affected by luminance level. They represent the ability to uniformly process the high frequency information at all luminance levels.

When differential gain is present, colour saturation is not correctly reproduced.

The input generator is the Rohde & Schwarz CCVS. The output measurement is done by the Rohde and Schwarz VSA.

Measurement on Rohde and Schwarz VSA.

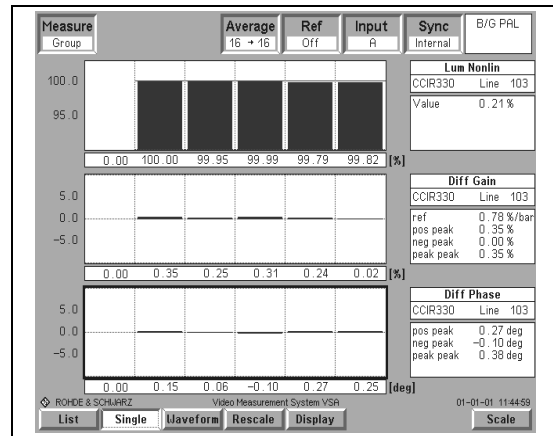

Video Results:

Parameter	Value (Vcc=±2.5V)	Value (Vcc=±5V)	Unit
Lum NL	0.1	0.3	%
Lum NL Step 1	100	100	%
Lum NL Step 2	100	99.9	%
Lum NL Step 3	99.9	99.8	%
Lum NL Step 4	99.9	99.9	%
Lum NL Step 5	99.9	99.7	%
Diff Gain pos	0	0	%
Diff Gain neg	-0.7	-0.6	%
Diff Gain pp	0.7	0.6	%
Diff Gain Step1	-0.5	-0.3	%
Diff Gain Step2	-0.7	-0.6	%
Diff Gain Step3	-0.3	-0.5	%
Diff Gain Step4	-0.1	-0.3	%
Diff Gain Step5	-0.4	-0.5	%
Diff Phase pos	0	0.1	deg
Diff Phase neg	-0.2	-0.4	deg
Diff Phase pp	0.2	0.5	deg
Diff Phase Step1	-0.2	-0.4	deg
Diff Phase Step2	-0.1	-0.4	deg
Diff Phase Step3	-0.1	-0.3	deg
Diff Phase Step4	0	0.1	deg
Diff Phase Step5	-0.2	-0.1	deg

Precautions on asymmetrical supply operation:

The TSH8X can be used either with a dual or a single supply. If a single supply is used, the inputs are biased to the mid-supply voltage ($+V_{CC}/2$). This bias network must be carefully designed, in order to reject any noise present on the supply rail.

As the bias current is 15 μ A, you must carefully choose the resistance R1 not to introduce an offset mismatch at the amplifier inputs.

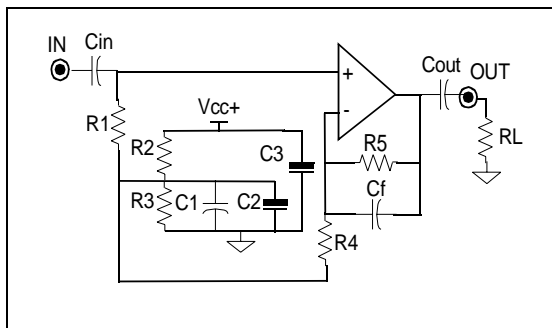

R1=10k Ω will be convenient. C1, C2, C3 are bypass capacitors from perturbation on Vcc as well as for the input and output signals. We choose C1=100nF and C2=C3=100 μ F.

R2, R3 are such that the current through them must be superior to 100 times the bias current. So, we take R2=R3=4.7k Ω .

Cin, as Cout are chosen to filter the DC signal by the low pass filters (R1, Cin) and (Rout, Cout). By taking R1=10k Ω , RL=150 Ω , and Cin=2 μ F, Cout=220 μ F we provide a cutoff frequency below 10Hz.

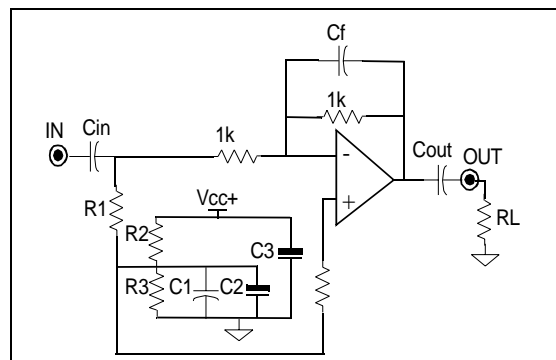
Use of the TSH8X in gain=-1 configuration:

Some precautions have to be added, specially for low power supply application.

A feedback capacitance Cf should be added for better stability. The table summarizes the impact of the capacitance Cf on the phase margin of the circuit.

TSH80-TSH81-TSH82

Parameter	Cf (pF)	Vcc=±1.5V	Vcc=±2.5V	Vcc=±5V	Unit
Phase Margin	0	28	43	56	deg
f-3dB		40	39.3	38.3	MHz
Phase Margin	5.6	30	43	56	deg
f-3dB		40	39.3	38.3	MHz
Phase Margin	22	37	52	67	deg
f-3dB		37	34	32	MHz
Phase Margin	33	48	65	78	deg
f-3dB		33.7	30.7	27.6	MHz

Example of a video application:

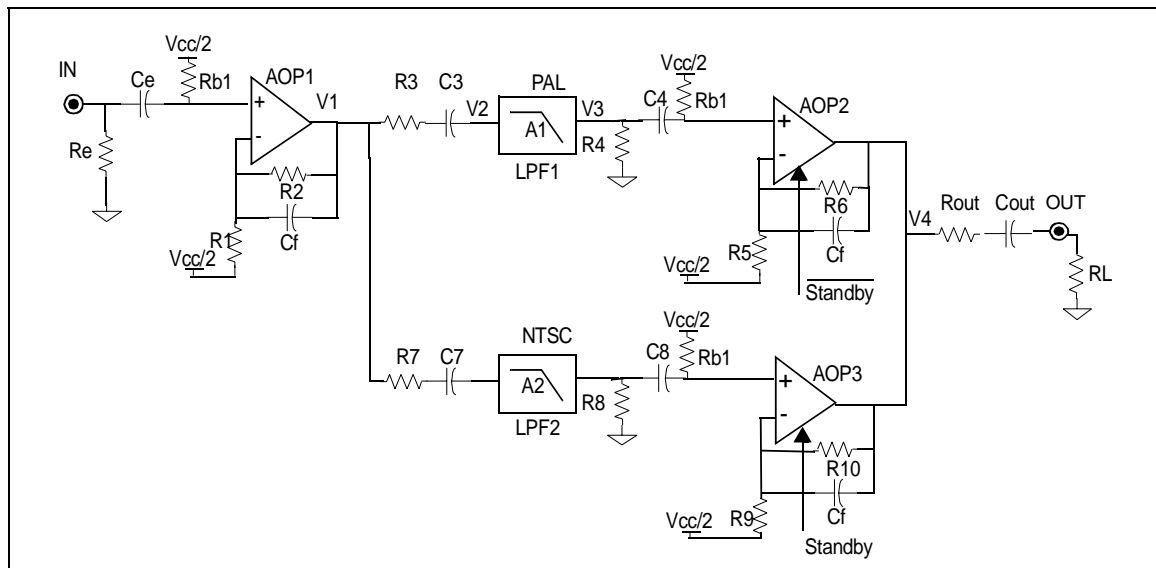

This example shows a possible application of the TSH8X circuit. Here, you can multiplex the channels for the different standard PAL, NTSC as you filter for the different bands; the video signal can be filtered with two different cutoff frequencies, corresponding to a PAL encoded signal (LPF1) or a NTSC signal (LPF2).

You can multiplex input signals, as the outputs are in high impedance state in standby mode. This enables you, to use a PAL filter as the Standby mode is active and to use the NTSC filter otherwise.

The video application requires 1V_{peak} at input and output.

Calculation of components:

A decoupling capacitor is provided to cutoff the frequencies below 10Hz according I bias. Hence $C_e=10\mu\text{F}$, with $R_{b1}=10\text{k}\Omega$. At the output, $C_{out}=220\mu\text{F}$.

The AOP1 is in 6dB configuration for the adaptation bridge. $R_1=R_2=1\text{k}\Omega$, $V_1=2\text{V}_{pk}$, $V_2=1\text{V}_{pk}$

For the PAL communication, we need a low pass filtering. The load resistance R_4 is function of the output resistance of the filter. $V_3=V_2/A_1$ where A_1 is the attenuation factor of the filter LPF1.

To compensate the filter insertion loss, we add an additional factor to the gain of the 2nd amplifier AOP2.

For example, for an attenuation of 3dB, we choose $R_5=300\Omega$ and $R_6=1\text{k}\Omega$. We have $V_4=2\text{V}_{pk}$ and $V_{out}=1\text{V}_{pk}$.

The calculation of the parameters R_7 , C_7 , R_8 , C_8 , R_9 , R_{10} will be exactly the same.

PACKAGE MECHANICAL DATA
8 PINS - PLASTIC MICROPACKAGE (SO)

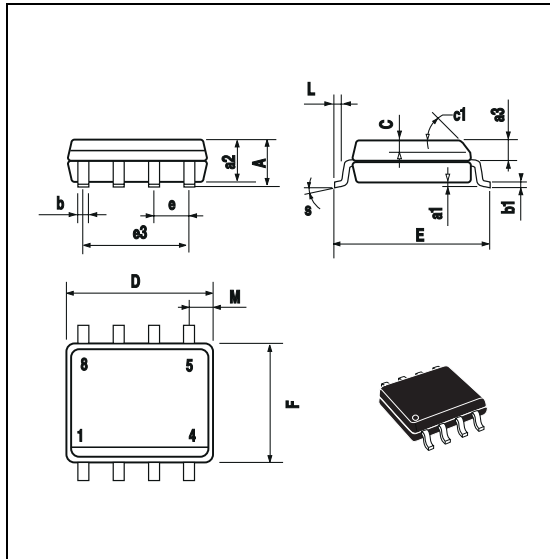

Dim.	Millimeters			Inches		
	Min.	Typ.	Max.	Min.	Typ.	Max.
A			1.75			0.069
a1	0.1		0.25	0.004		0.010
a2			1.65			0.065
a3	0.65		0.85	0.026		0.033
b	0.35		0.48	0.014		0.019
b1	0.19		0.25	0.007		0.010
C	0.25		0.5	0.010		0.020
c1	45° (typ.)					
D	4.8		5.0	0.189		0.197
E	5.8		6.2	0.228		0.244
e		1.27			0.050	
e3		3.81			0.150	
F	3.8		4.0	0.150		0.157
L	0.4		1.27	0.016		0.050
M			0.6			0.024
S	8° (max.)					

PACKAGE MECHANICAL DATA
8 PINS - THIN SHRINK SMALL OUTLINE
PACKAGE (TSSOP)

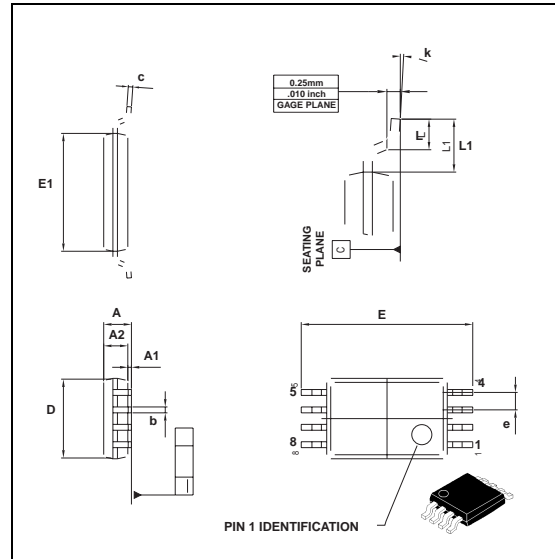

Dim.	Millimeters			Inches		
	Min.	Typ.	Max.	Min.	Typ.	Max.
A			1.20			0.05
A1	0.05		0.15	0.01		0.006
A2	0.80	1.00	1.05	0.031	0.039	0.041
b	0.19		0.30	0.007		0.15
c	0.09		0.20	0.003		0.012
D	2.90	3.00	3.10	0.114	0.118	0.122
E		6.40			0.252	
E1	4.30	4.40	4.50	0.169	0.173	0.177
e		0.65			0.025	
k	0°		8°	0°		8°
l	0.50	0.60	0.75	0.09	0.0236	0.030

PACKAGE MECHANICAL DATA

5 PINS - TINY PACKAGE (SOT23)

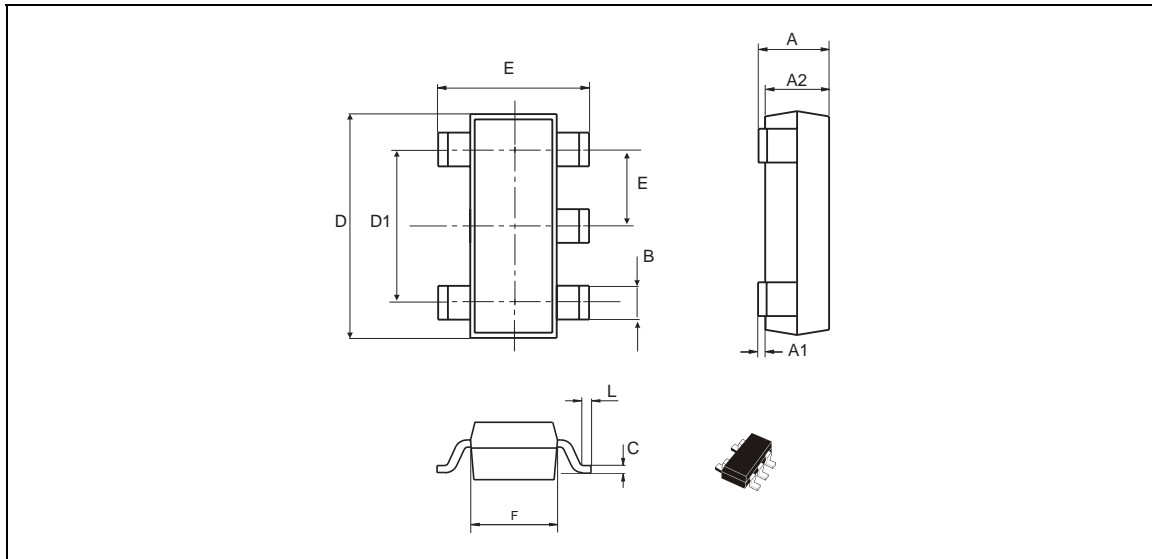

Dim.	Millimeters			Inches		
	Min.	Typ.	Max.	Min.	Typ.	Max.
A	0.90	1.20	1.45	0.035	0.047	0.057
A1	0		0.15			0.006
A2	0.90	1.05	1.30	0.035	0.041	0.051
B	0.35	0.40	0.50	0.014	0.016	0.020
C	0.09	0.15	0.20	0.004	0.006	0.008
D	2.80	2.90	3.00	0.110	0.114	0.118
D1		1.90			0.075	
e		0.95			0.037	
E	2.60	2.80	3.00	0.102	0.110	0.0118
F	1.50	1.60	1.75	0.059	0.063	0.069
L	0.10	0.5	0.60	0.004	0.014	0.024
K	0d		10d	0d		10d

Information furnished is believed to be accurate and reliable. However, STMicroelectronics assumes no responsibility for the consequences of use of such information nor for any infringement of patents or other rights of third parties which may result from its use. No license is granted by implication or otherwise under any patent or patent rights of STMicroelectronics. Specifications mentioned in this publication are subject to change without notice. This publication supersedes and replaces all information previously supplied. STMicroelectronics products are not authorized for use as critical components in life support devices or systems without express written approval of STMicroelectronics.

The ST logo is a registered trademark of STMicroelectronics

© 2003 STMicroelectronics - Printed in Italy - All Rights Reserved
STMicroelectronics GROUP OF COMPANIES

Australia - Brazil - Canada - China - Finland - France - Germany - Hong Kong - India - Israel - Italy - Japan - Malaysia
Malta - Morocco - Singapore - Spain - Sweden - Switzerland - United Kingdom - United States

<http://www.st.com>

