

FEATURES

- 14-bit resolution
- 8MHz guaranteed sampling rate
- No missing codes over full military temperature range
- Ideal for both time and frequency-domain applications
- Excellent THD (-75dB) and SNR (77dB)
- Edge-triggered; No pipeline delays
- Small, 24-pin, ceramic DDIP or SMT
- Requires only ±5V supplies
- Low-power, 2 Watts
- MIL-STD-883 screening optional



GENERAL DESCRIPTION

The low-cost ADS-946 is a 14-bit, 8MHz sampling A/D converter. This device accurately samples full-scale input signals up to Nyquist frequencies with no missing codes. Excellent differential nonlinearity error (DNL), signal-to-noise ratio (SNR), and total harmonic distortion (THD) make the ADS-946 the ideal choice for both time-domain (CCD/FPA imaging, scanners, process control) and frequency-domain (radar, telecommunications, spectrum analysis) applications.

The functionally complete ADS-946 contains a fast-settling sample-hold amplifier, a subranging (two-pass) A/D converter, an internal reference, timing/control logic, and error-correction circuitry. Digital input and output levels are TTL. The ADS-946 only requires the rising edge of a start convert pulse to operate.

Requiring only ±5V supplies, the ADS-946 typically dissipates just 2 Watts. The device is offered with a bipolar input range of ±2V. Models are available for use in either commercial (0 to +70°C) or military (-55 to +125°C) operating

INPUT/OUTPUT CONNECTIONS

PIN	FUNCTION	PIN	FUNCTION
1	BIT 1 (MSB)	24	ANALOG GROUND
2	BIT 2	23	OFFSET ADJUST
3	BIT 3	22	+5V ANALOG SUPPLY
4	BIT 4	21	ANALOG INPUT
5	BIT 5	20	-5V SUPPLY
6	BIT 6	19	ANALOG GROUND
7	BIT 7	18	START CONVERT
8	BIT 8	17	EOC
9	BIT 9	16	BIT 14 (LSB)
10	BIT 10	15	BIT 13
11	BIT 11	14	DIGITAL GROUND
12	BIT 12	13	+5V DIGITAL SUPPLY

temperature ranges. A proprietary, auto-calibrating, error-correcting circuit allows the device to achieve specified performance over the full military temperature range.

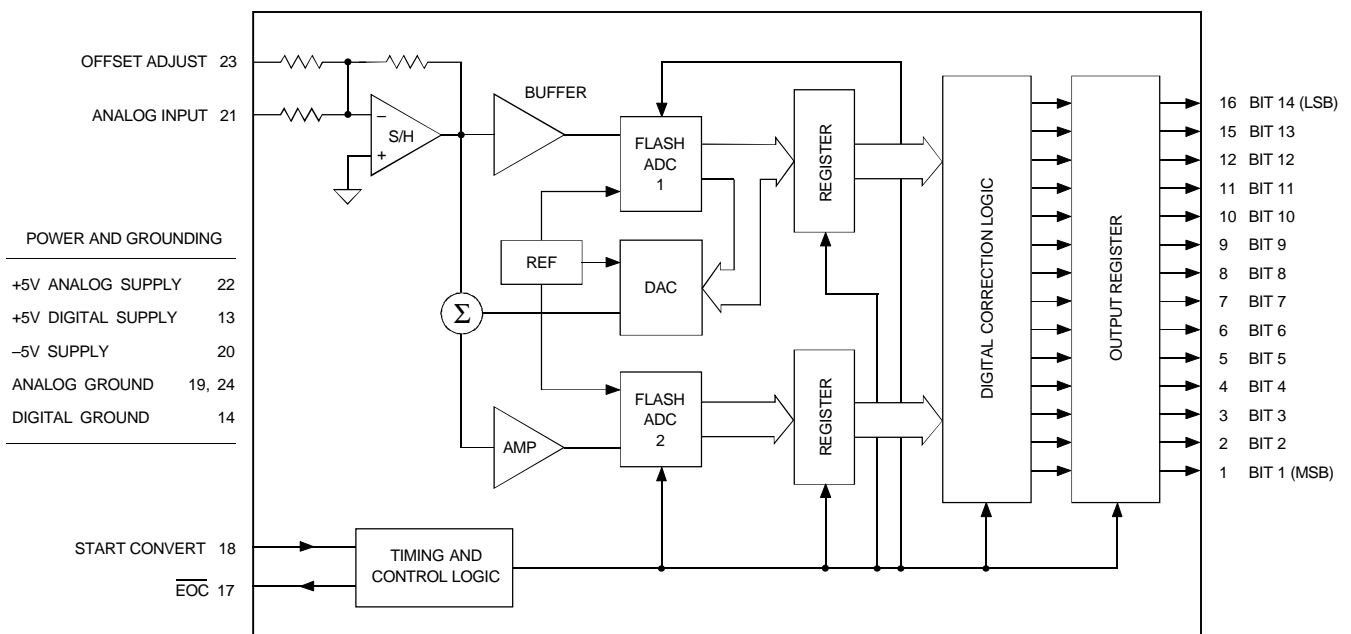

Figure 1. ADS-946 Functional Block Diagram

ABSOLUTE MAXIMUM RATINGS

PARAMETERS	LIMITS	UNITS
+5V Supply (Pins 13, 22)	0 to +6	Volts
-5V Supply (Pin 20)	0 to -6	Volts
Digital Input (Pin 18)	-0.3 to +VDD +0.3	Volts
Analog Input (Pin 21)	±5	Volts
Lead Temperature (10 seconds)	+300	°C

PHYSICAL/ENVIRONMENTAL

PARAMETERS	MIN.	TYP.	MAX.	UNITS
Operating Temp. Range, Case	0	—	+70	°C
	-55	—	+125	°C
ADS-946MC, GC				
ADS-946MM, GM, 883, G/883				
Thermal Impedance	—	6	—	°C/Watt
	—	23	—	°C/Watt
	—	—	—	°C
Storage Temperature Range	-65	—	+150	°C
Package Type	24-pin, metal-sealed, ceramic DDIP or SMT			
Weight	0.42 ounces (12 grams)			

FUNCTIONAL SPECIFICATIONS

(TA = +25°C, ±VDD = ±5V, 8MHz sampling rate, and a minimum 3 minute warmup ① unless otherwise specified.)

ANALOG INPUT	+25°C			0 to +70°C			-55 to +125°C			UNITS
	MIN.	TYP.	MAX.	MIN.	TYP.	MAX.	MIN.	TYP.	MAX.	
Input Voltage Range ②	—	±2	—	—	±2	—	—	±2	—	Volts
Input Resistance	—	200	—	—	200	—	—	200	—	Ω
Input Capacitance	—	6	15	—	6	15	—	6	15	pF
DIGITAL INPUT										
Logic Levels										
Logic "1"	+2.0	—	—	+2.0	—	—	+2.0	—	—	Volts
Logic "0"	—	—	+0.8	—	—	+0.8	—	—	+0.8	Volts
Logic Loading "1"	—	—	+20	—	—	+20	—	—	+20	μA
Logic Loading "0"	—	—	-20	—	—	-20	—	—	-20	μA
Start Convert Positive Pulse Width ③	10	20	—	10	20	—	10	20	—	ns
STATIC PERFORMANCE										
Resolution	—	14	—	—	14	—	—	14	—	Bits
Integral Nonlinearity (fin = 10kHz)	—	±0.75	—	—	±0.75	—	—	±1	—	LSB
Differential Nonlinearity (fin = 10kHz)	-0.95	±0.5	+1.25	-0.95	±0.5	+1.25	-0.95	±0.75	+1.99	LSB
Full Scale Absolute Accuracy	—	±0.15	±0.4	—	±0.15	±0.4	—	±0.4	±0.8	%FSR
Bipolar Zero Error (Tech Note 2)	—	±0.2	±0.4	—	±0.2	±0.4	—	±0.4	±0.65	%FSR
Gain Error (Tech Note 2)	—	±0.2	±0.75	—	±0.2	±0.75	—	±0.4	±1.25	%
No Missing Codes (fin = 10kHz)	14	—	—	14	—	—	14	—	—	Bits
DYNAMIC PERFORMANCE										
Peak Harmonics (-0.5dB)										
dc to 500kHz	—	-76	-72	—	-76	-72	—	-74	-70	dB
500kHz to 1MHz	—	-75	-72	—	-75	-72	—	-74	-68	dB
1MHz to 4MHz	—	-75	-71	—	-75	-71	—	-69	-65	dB
Total Harmonic Distortion (-0.5dB)										
dc to 500kHz	—	-75	-71	—	-75	-71	—	-74	-70	dB
500kHz to 1MHz	—	-75	-70	—	-75	-70	—	-72	-68	dB
1MHz to 4MHz	—	-75	-70	—	-75	-70	—	-69	-64	dB
Signal-to-Noise Ratio (w/o distortion, -0.5dB)										
dc to 500kHz	73	77	—	73	77	—	72	76	—	dB
500kHz to 1MHz	73	77	—	73	77	—	72	76	—	dB
1MHz to 4MHz	73	77	—	73	77	—	72	76	—	dB
Signal-to-Noise Ratio ④ (& distortion, -0.5dB)										
dc to 500kHz	70	74	—	70	74	—	68	73	—	dB
500kHz to 1MHz	69	73	—	69	73	—	65	70	—	dB
1MHz to 4MHz	69	73	—	69	73	—	65	70	—	dB
Noise	—	150	—	—	150	—	—	150	—	μVrms
Two-Tone Intermodulation Distortion (fin = 2.45MHz, 1.975MHz, fs = 8MHz, -0.5dB)	—	-82	—	—	-82	—	—	-82	—	dB
Input Bandwidth (-3dB)										
Small Signal (-20dB input)	—	30	—	—	30	—	—	30	—	MHz
Large Signal (-0.5dB input)	—	10	—	—	10	—	—	10	—	MHz
Feedthrough Rejection (fin = 4MHz)	—	85	—	—	85	—	—	85	—	dB
Slew Rate	—	±400	—	—	±400	—	—	±400	—	V/μs
Aperture Delay Time	—	+5	—	—	+5	—	—	+5	—	ns
Aperture Uncertainty	—	2	—	—	2	—	—	2	—	ps rms

DYNAMIC PERFORMANCE (Cont.)	+25°C			0 to +70°C			-55 to +125°C			UNITS
	MIN.	TYP.	MAX.	MIN.	TYP.	MAX.	MIN.	TYP.	MAX.	
S/H Acquisition Time (to ±0.003%FSR, 4V step)	—	55	60	—	55	60	—	55	60	ns
Overvoltage Recovery Time ⑤	—	100	125	—	100	125	—	100	125	ns
A/D Conversion Rate	8	—	—	8	—	—	8	—	—	MHz
DIGITAL OUTPUTS										
Logic Levels										
Logic "1"	+2.4	—	—	+2.4	—	—	+2.4	—	—	Volts
Logic "0"	—	—	+0.4	—	—	+0.4	—	—	+0.4	Volts
Logic Loading "1"	—	—	-4	—	—	-4	—	—	-4	mA
Logic Loading "0"	—	—	+4	—	—	+4	—	—	+4	mA
Output Coding	Offset Binary									
POWER REQUIREMENTS										
Power Supply Ranges ⑥										
+5V Supply	+4.75	+5.0	+5.25	+4.75	+5.0	+5.25	+4.9	+5.0	+5.25	Volts
-5V Supply	-4.75	-5.0	-5.25	-4.75	-5.0	-5.25	-4.9	-5.0	-5.25	Volts
Power Supply Currents										
+5V Supply	—	+250	+270	—	+250	+270	—	+250	+270	mA
-5V Supply	—	-150	-170	—	-150	-170	—	-150	-170	mA
Power Dissipation	—	2	2.2	—	2	2.2	—	2	2.2	Watts
Power Supply Rejection	—	—	±0.05	—	—	±0.05	—	—	±0.05	%FSR/%V
Footnotes:										
① All power supplies should be on before applying a start convert pulse. All supplies and the clock (start convert pulses) must be present during warmup periods. The device must be continuously converting during this time.						④ Effective bits is equal to: $\frac{(\text{SNR} + \text{Distortion}) - 1.76 + \left[20 \log \frac{\text{Full Scale Amplitude}}{\text{Actual Input Amplitude}} \right]}{6.02}$				
② Contact DATEL for other input voltage ranges.						⑤ This is the time required before the A/D output data is valid once the analog input is back within the specified range. This time is only guaranteed if the input does not exceed ±2.2V (S/H saturation voltage).				
③ An 8MHz clock with a 20nsec positive pulse width is used for all production testing. See Timing Diagram, Figure 4, for more details.						⑥ The minimum supply voltages of +4.9V and -4.9V for ±VDD are required for -55°C operation only. The minimum limits are +4.75V and -4.75V when operating at +125°C				

TECHNICAL NOTES

1. Obtaining fully specified performance from the ADS-946 requires careful attention to pc card layout and power supply decoupling. The device's analog and digital ground systems are connected to each other internally. For optimal performance, tie all ground pins (14, 19 and 24) directly to a large *analog* ground plane beneath the package.

Bypass all power supplies to ground with 4.7µF tantalum capacitors in parallel with 0.1µF ceramic capacitors. Locate the bypass capacitors as close to the unit as possible.

2. The ADS-946 achieves its specified accuracies without the need for external calibration. If required, the device's small initial offset and gain errors can be reduced to zero using the adjustment circuitry shown in Figures 2 and 3. When using this circuitry, or any similar offset and gain calibration hardware, make adjustments following warmup. To avoid interaction, always adjust offset before gain.

- 3. Applying a start convert pulse while a conversion is in progress (EOC = logic 1) will initiate a new and inaccurate conversion cycle. Data for the interrupted and subsequent conversions will be invalid.
- 4. A passive bandpass filter is used at the input of the A/D for all production testing.

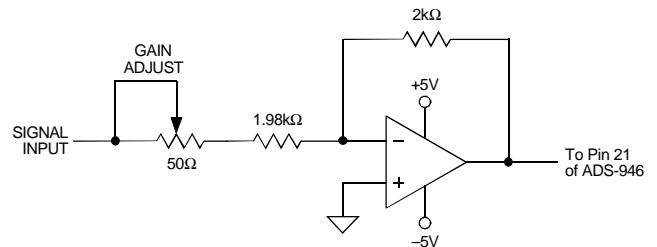

Figure 2. Optional ADS-946 Gain Adjust Calibration Circuit

CALIBRATION PROCEDURE

Any offset and/or gain calibration procedures should not be implemented until devices are fully warmed up. To avoid interaction, offset must be adjusted before gain. The ranges of adjustment for the circuits in Figures 2 and 3 are guaranteed to compensate for the ADS-946's initial accuracy errors and may not be able to compensate for additional system errors.

A/D converters are calibrated by positioning their digital outputs exactly on the transition point between two adjacent digital output codes. This can be accomplished by connecting LED's to the digital outputs and adjusting until certain LED's "flicker" equally between on and off. Other approaches employ digital comparators or microcontrollers to detect when the outputs change from one code to the next.

Offset adjusting for the ADS-946 is normally accomplished at the point where the MSB is a 1 and all other output bits are 0's and the LSB just changes from a 0 to a 1. This digital output transition ideally occurs when the applied analog input is $\pm\frac{1}{2}$ LSB (+122 μ V).

Gain adjusting is accomplished when all bits are 1's and the LSB just changes from a 1 to a 0. This transition ideally occurs when the analog input is at +full scale minus $1\frac{1}{2}$ LSB's (+1.99963V).

Zero/Offset Adjust Procedure

1. Apply a train of pulses to the START CONVERT input (pin 18) so the converter is continuously converting.
2. Apply +122 μ V to the ANALOG INPUT (pin 21).
3. Adjust the offset potentiometer until the output bits are 10 0000 0000 0000 and the LSB flickers between 0 and 1.

Gain Adjust Procedure

1. Apply +1.99963V to the ANALOG INPUT (pin 21).
2. Adjust the gain potentiometer until all output bits are 1's and the LSB flickers between 1 and 0.
3. To confirm proper operation of the device, vary the input signal to obtain the output coding listed in Table 2.

Table 1. Gain and Zero Adjust

INPUT VOLTAGE RANGE	ZERO ADJUST $\pm\frac{1}{2}$ LSB	GAIN ADJUST $\pm FS - \frac{1}{2}$ LSB
$\pm 2V$	+122 μ V	+1.99963V

Table 2. Output Coding for Bipolar Operation

BIPOLAR SCALE	INPUT VOLTAGE ($\pm 2V$ RANGE)	OFFSET BINARY MSB LSB
+FS - 1 LSB	+1.99976	11 1111 1111 1111
+3/4 FS	+1.50000	11 1000 0000 0000
+1/2 FS	+1.00000	11 0000 0000 0000
0	0.00000	10 0000 0000 0000
-1/2 FS	-1.00000	01 0000 0000 0000
-3/4 FS	-1.50000	00 1000 0000 0000
-FS + 1 LSB	-1.99976	00 0000 0000 0001
-FS	-2.00000	00 0000 0000 0000

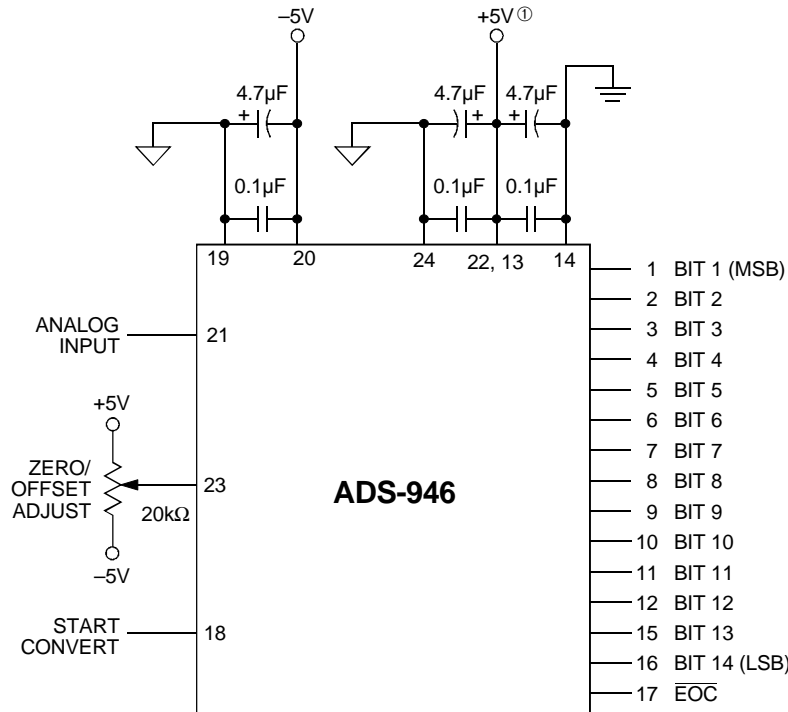

① A single +5V supply should be used for both the +5V analog and +5V digital. If separate supplies are used, the difference between the two cannot exceed 100mV.

Figure 3. Typical ADS-946 Connection Diagram

THERMAL REQUIREMENTS

All DATEL sampling A/D converters are fully characterized and specified over operating temperature (case) ranges of 0 to +70°C and -55 to +125°C. All room-temperature (TA = +25°C) production testing is performed without the use of heat sinks or forced-air cooling. Thermal impedance figures for each device are listed in their respective specification tables.

These devices do not normally require heat sinks, however, standard precautionary design and layout procedures should be used to ensure devices do not overheat. The ground and power planes beneath the package, as well as all pcb signal runs to and from the device, should be as heavy as possible to help conduct heat away from the package.

Electrically-insulating, thermally-conductive "pads" may be installed underneath the package. Devices should be soldered to boards rather than socketed, and of course, minimal air flow over the surface can greatly help reduce the package temperature.

In more severe ambient conditions, the package/junction temperature of a given device can be reduced dramatically (typically 35%) by using one of DATEL's HS Series heat sinks. See Ordering Information for the assigned part number. See page 1-183 of the DATEL Data Acquisition Components Catalog for more information on the HS Series. Request DATEL Application Note AN-8, "Heat Sinks for DIP Data Converters," or contact DATEL directly, for additional information.

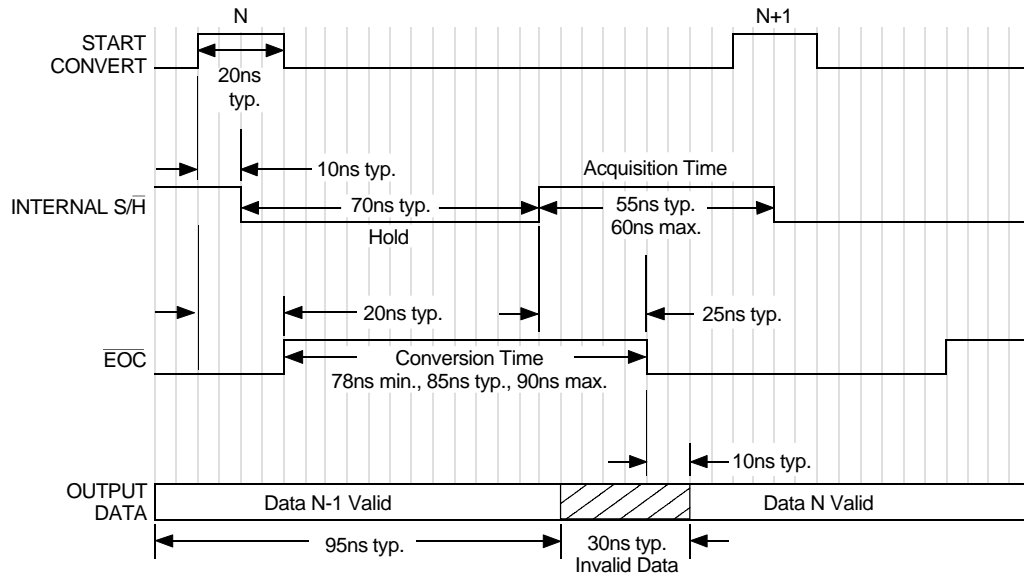

Notes:

1. Scale is approximately 5ns per division. Sampling rate = 8MHz.
2. The start convert positive pulse width must be between 10 and 50ns or between 80 and 110ns (when sampling at 8MHz) to ensure proper operation. For sampling rates less than 8MHz, the start pulse can be wider than 110nsec, however a minimum pulse width low of 15nsec should be maintained. An 8MHz clock with a 20nsec positive pulse width is used for all production testing.

Figure 4. ADS-946 Timing Diagram

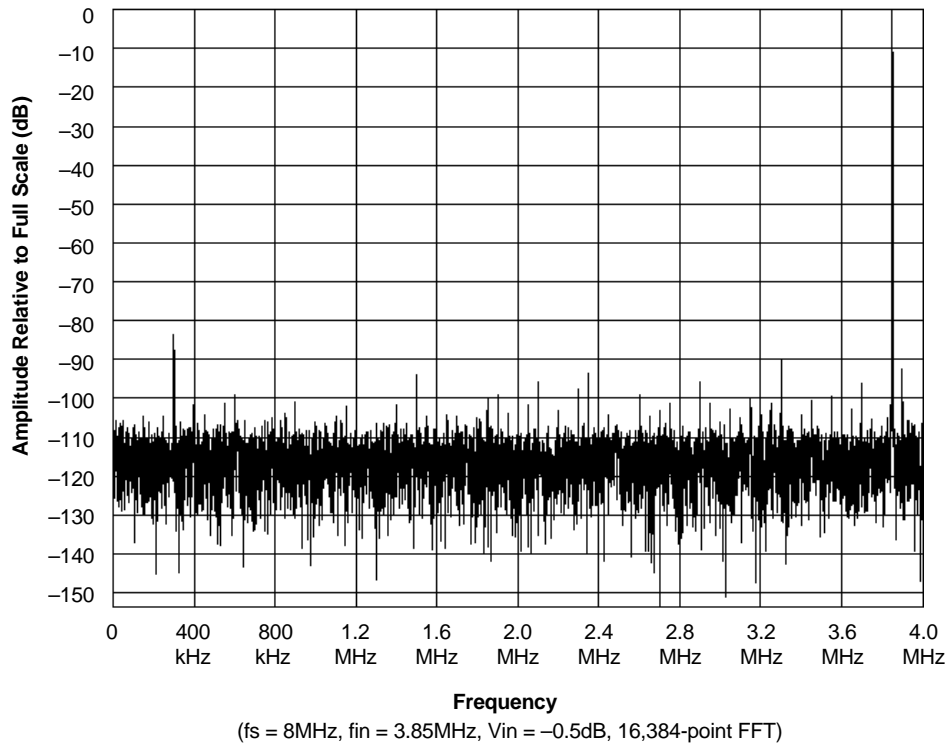

Figure 5. FFT Analysis of ADS-946

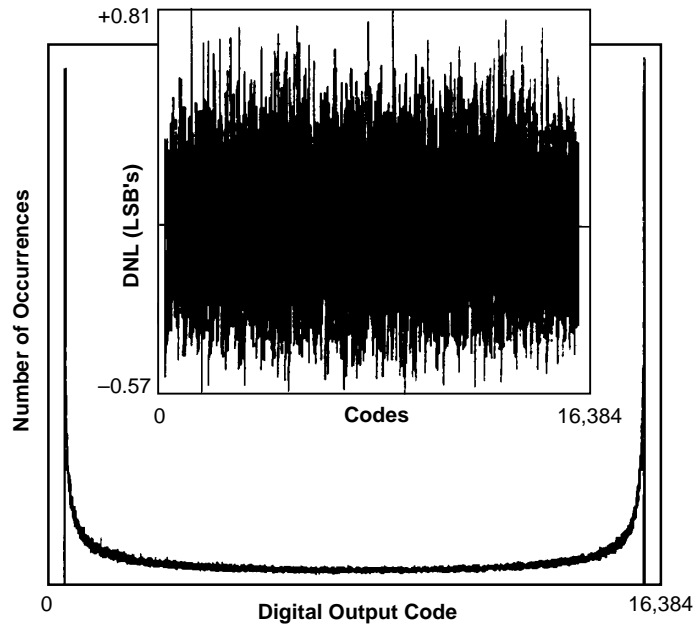
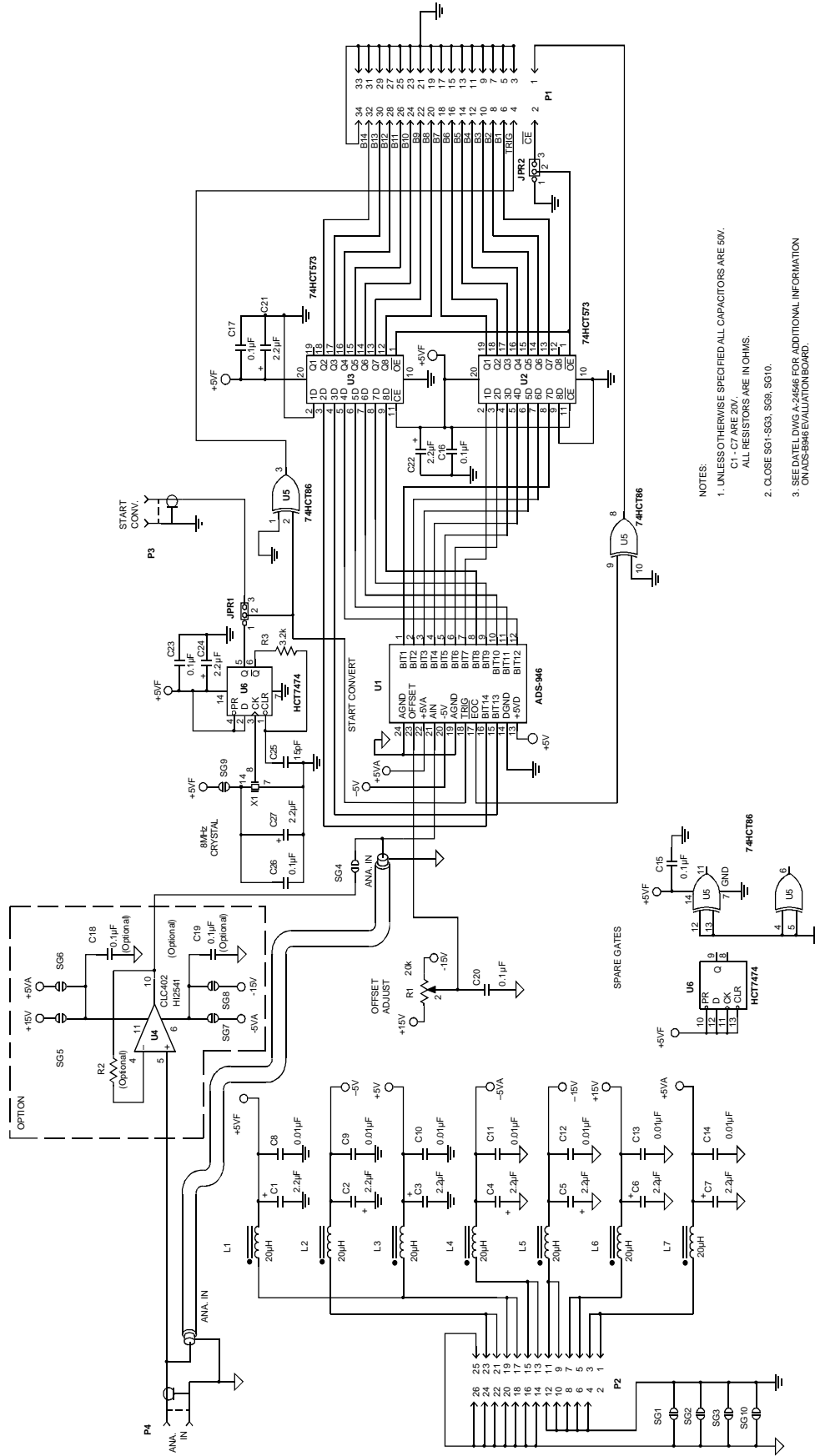

Figure 6. ADS-946 Histogram and Differential Nonlinearity



- NOTES:
1. UNLESS OTHERWISE SPECIFIED ALL CAPACITORS ARE 50V. C1 - C7 ARE 20V. ALL RESISTORS ARE IN OHMS.
 2. CLOSE S61-S63, S68, S610.
 3. SEE DATTEL DYNASIS FOR ADDITIONAL INFORMATION ON ADS-B946 EVALUATION BOARD.

Figure 7. ADS-946 Evaluation Board Schematic (ADS-B946)

MECHANICAL DIMENSIONS INCHES (mm)

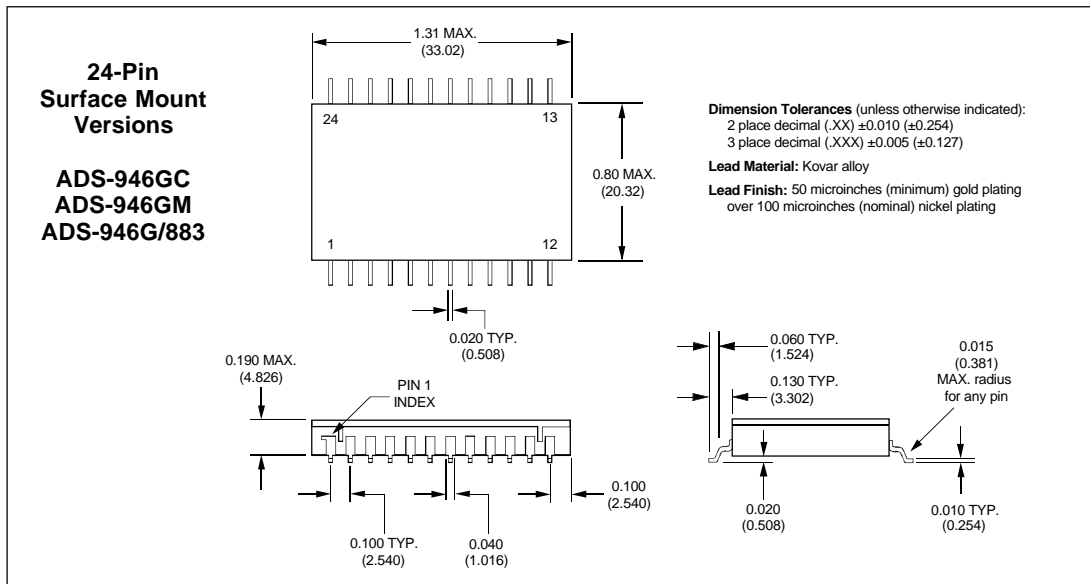
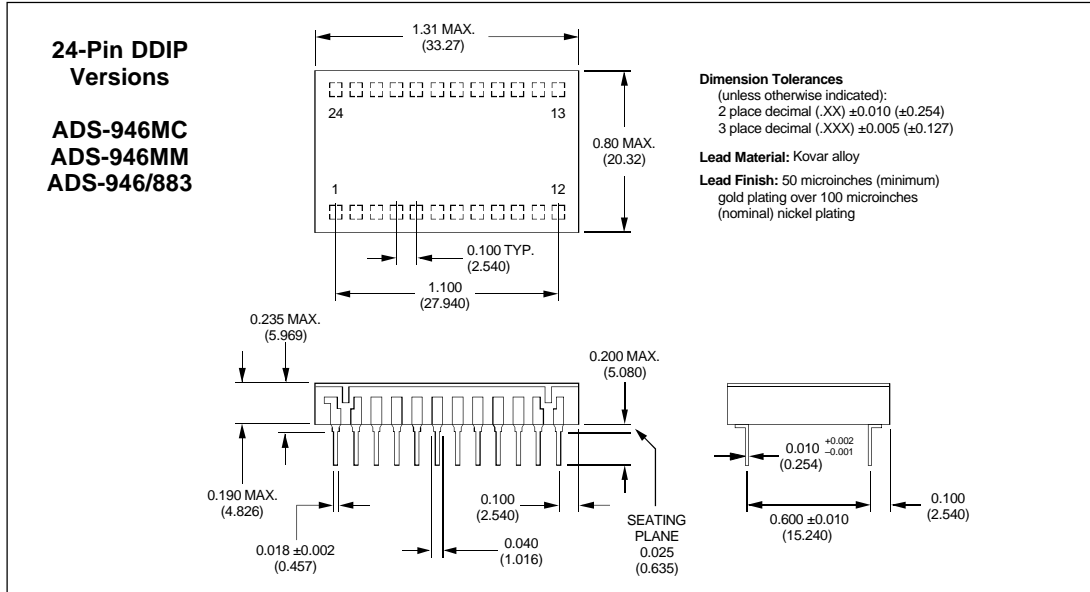

ORDERING INFORMATION

MODEL	OPERATING TEMP. RANGE	24-PIN PACKAGE	ACCESSORIES
ADS-946MC	0 to +70°C	DDIP	ADS-B946 Evaluation Board (without ADS-946)
ADS-946MM	-55 to +125°C	DDIP	HS-24 Heat Sink for all ADS-946 DDIP models
ADS-946/883	-55 to +125°C	DDIP	
ADS-946GC	0 to +70°C	SMT	
ADS-946GM	-55 to +125°C	SMT	
ADS-946G/883	-55 to +125°C	SMT	

Receptacles for pc board mounting can be ordered through AMP, Inc., Part # 3-331272-8 (Component Lead Socket), 24 required. For MIL-STD-883 product specification, contact DATEL.