

Features

- This Circuit is Processed in Accordance to MIL-STD-883 and is Fully Conformant Under the Provisions of Paragraph 1.2.1.
- Exceeds 2kV ESD Protection MIL-STD-883, Method 3015
- Meets JEDEC Standard No. 20
- SCR - Latch-Up-Resistant CMOS Process and Circuit Design
- Speed of Bipolar FAST/A/S with Significantly Reduced Power Consumption
- Functionally and Pin-Compatible with Industry 54 Bipolar Types in the FAST, AS and S Series
- Balanced Propagation Delays
- Military Operating Temperature Range
 - Ceramic (CERDIP) 54 Series: -55 to 125°C
- ±24mA Output Drive Current, Drives 75Ω Lines without Need for Terminations
- Fan Out (Over Temperature)
 - ACL Loads 2400
 - FAST Loads..... 15
 - AS Loads..... 48
- Balanced Noise Immunity at 30% of Supply for AC Types
- Supply Voltage Range
 - AC Types 1.5V to 5.5V
 - ACT Types 4.5V to 5.5V

Pinout

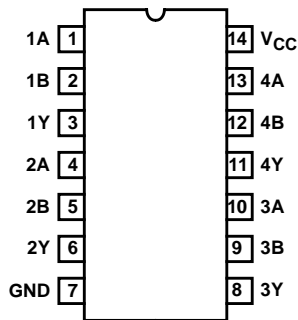

Description

The CD54AC00F3A and CD54ACT00F3A are quad 2-input NAND gates that utilize the Harris Advanced CMOS Logic technology.

Ordering Information

PART NUMBER	TEMP. RANGE (°C)	PACKAGE	PKG. NO.
CD54AC00F3A	-55 to 125	14 Ld CERDIP	F14.3
CD54ACT00F3A	-55 to 125	14 Ld CERDIP	F14.3

NOTE:

1. Wafer and die for this part number is available which meets all electrical specifications. Please contact your local sales office or Harris customer service for ordering information.

Functional Diagram

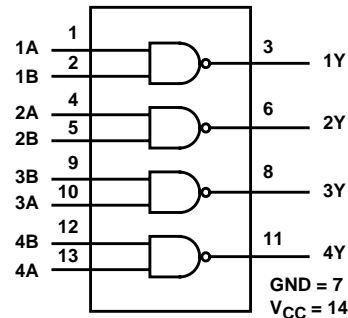

TRUTH TABLE

INPUTS		OUTPUTS
A	B	Y
L	L	H
H	L	H
L	H	H
H	H	L

CD54AC00F3A, CD54ACT00F3A

Absolute Maximum Ratings

DC Supply Voltage, V_{CC}	-0.5V to 6V
DC Input Diode Current, I_{IK}	
For $V_I < -0.5V$ or $V_I > V_{CC} + 0.5V$	$\pm 20mA$
DC Output Diode Current, I_{OK}	
For $V_O < -0.5V$ or $V_O > V_{CC} + 0.5V$	$\pm 50mA$
DC Output Source or Sink Current per Output Pin, I_O	
For $V_O > -0.5V$ or $V_O < V_{CC} + 0.5V$	$\pm 50mA$
DC V_{CC} or Ground Current, I_{CC} or I_{GND} (Note 2)	$\pm 100mA$

Thermal Information

Thermal Resistance (Typical, Note 4)	θ_{JA} ($^{\circ}C/W$)	θ_{JC} ($^{\circ}C/W$)
CERDIP Package	80	24
Maximum Junction Temperature (Hermetic Package or Die) ...	175 $^{\circ}C$	
Maximum Storage Temperature Range	-65 $^{\circ}C$ to 150 $^{\circ}C$	
Maximum Lead Temperature (Soldering 10s)	300 $^{\circ}C$	

Operating Conditions

Temperature Range, T_A	-55 $^{\circ}C$ to 125 $^{\circ}C$
Supply Voltage Range, V_{CC} (Note 3)	
AC Types	1.5V to 5.5V
ACT Types	4.5V to 5.5V
DC Input or Output Voltage, V_I , V_O	0V to V_{CC}
Input Rise and Fall Slew Rate, dt/dv	
AC Types	
1.5V to 3V	50ns (Max)
3.6V to 5.5V	20ns (Max)
4.5V to 5.5V	10ns (Max)

CAUTION: Stresses above those listed in "Absolute Maximum Ratings" may cause permanent damage to the device. This is a stress only rating and operation of the device at these or any other conditions above those indicated in the operational sections of this specification is not implied.

NOTES:

2. For up to 4 outputs per device, add $\pm 25mA$ for each additional output.
3. Unless otherwise specified, all voltages are referenced to ground.
4. θ_{JA} is measured with the component mounted on an evaluation PC board in free air.

DC Electrical Specifications

PARAMETER	SYMBOL	TEST CONDITIONS		V_{CC} (V)	25 $^{\circ}C$		-55 $^{\circ}C$ TO 125 $^{\circ}C$		UNITS	
		V_I (V)	I_O (mA)		MIN	MAX	MIN	MAX		
AC TYPES										
High Level Input Voltage	V_{IH}	-	-	1.5	1.2	-	1.2	-	V	
				3	2.1	-	2.1	-	V	
				4.5	3.15 (Note 5)	-	3.15 (Note 5)	-	V	
				5.5	3.85	-	3.85	-	V	
Low Level Input Voltage	V_{IL}	-	-	1.5	-	0.3	-	0.3	V	
				3	-	0.9	-	0.9	V	
				4.5	-	1.35 (Note 5)	-	1.35 (Note 5)	V	
				5.5	-	1.65	-	1.65	V	
High Level Output Voltage	V_{OH}	V_{IH} or V_{IL}	-0.05	-0.05	1.5	1.4	-	1.4	-	V
			-0.05	-0.05	3	2.9	-	2.9	-	V
			-0.05	-0.05	4.5	4.4	-	4.4	-	V
			-4	-4	3	2.58	-	2.4	-	V
			-24	-24	4.5	3.94 (Note 5)	-	3.7 (Note 5)	-	V
			-50 (Note 6, 7)	-50	5.5	-	-	3.85	-	V

CD54AC00F3A, CD54ACT00F3A

DC Electrical Specifications (Continued)

PARAMETER	SYMBOL	TEST CONDITIONS		V _{CC} (V)	25°C		-55°C TO 125°C		UNITS
		V _I (V)	I _O (mA)		MIN	MAX	MIN	MAX	
Low Level Output Voltage	V _{OL}	V _{IH} or V _{IL}	0.05	1.5	-	0.1	-	0.1	V
			0.05	3	-	0.1	-	0.1	V
			0.05	4.5	-	0.1	-	0.1	V
			12	3	-	0.36	-	0.5	V
			24	4.5	-	0.36 (Note 5)	-	0.5 (Note 5)	V
			50 (Note 6, 7)	5.5	-	-	-	1.65	V
Input Leakage Current	I _I	V _{CC} or GND	-	5.5	-	±0.1 (Note 5)	-	±1 (Note 5)	μA
Quiescent Device Current	I _{CC}		0	5.5	-	4 (Note 5)	-	80 (Note 5)	μA
ACT TYPES									
High Level Input Voltage	V _{IH}	-	-	4.5 to 5.5	2 (Note 5)	-	2 (Note 5)	-	V
Low Level Input Voltage	V _{IL}	-	-	4.5 to 5.5	-	0.8 (Note 5)	-	0.8 (Note 5)	V
High Level Output Voltage	V _{OH}	V _{IH} or V _{IL}	-0.05	4.5	4.4	-	4.4	-	V
			-24	4.5	3.94 (Note 5)	-	3.7 (Note 5)	-	V
			-50 (Note 6, 7)	5.5	-	-	3.85	-	V
Low Level Output Voltage	V _{OL}	V _{IH} or V _{IL}	0.05	4.5	-	0.1	-	0.1	V
			24	4.5	-	0.36 (Note 5)	-	0.5 (Note 5)	V
			50 (Note 6, 7)	5.5	-	-	-	1.65	V
Input Leakage Current	I _I	V _{CC} or GND	-	5.5	-	±0.1 (Note 5)	-	±1 (Note 5)	μA
Quiescent Device Current	I _{CC}	V _{CC} or GND	0	5.5	-	4 (Note 5)	-	80 (Note 5)	μA
Additional Supply Current per Input Pin TTL Inputs High 1 Unit Load	ΔI _{CC}	V _{CC} -2.1	-	4.5 to 5.5	-	2.4	-	3	mA

NOTES:

5. Tested at 100%.
6. Test one output at a time for a 1-second maximum duration. Measurement is made by forcing current and measuring voltage to minimize power dissipation.
7. Test verifies a minimum transmission-line-drive capability of 75Ω for 54AC/ACT Series.

ACT Input Load Table

INPUT	UNIT LOAD
All	0.15

NOTE: Unit load is ΔI_{CC} limit specified in DC Electrical Specifications Table, e.g., 2.4mA max at 25°C.

CD54AC00F3A, CD54ACT00F3A

Switching Specifications Input t_r , $t_f = 3\text{ns}$, $C_L = 50\text{pF}$ (Worst Case)

PARAMETER	SYMBOL	V_{CC} (V)	-55°C TO 125°C			UNITS
			MIN	TYP	MAX	
AC TYPES						
Propagation Delay, Input to Output	t_{PLH} , t_{PHL}	1.5	-	-	91	ns
		3.3 (Note 9)	3.1	-	10.2	ns
		5 (Note 10)	2.2	-	7.3 (Note 8)	ns
Input Capacitance	C_I	-	-	-	10	pF
Power Dissipation Capacitance	C_{PD} (Note 11)	-	-	45	-	pF
ACT TYPES						
Propagation Delay, Input to Output	t_{PLH}	5 (Note 10)	3.2	-	10.8 (Note 8)	ns
	t_{PHL}		4	-	13.2 (Note 8)	ns
Input Capacitance	C_I	-	-	-	10	pF
Power Dissipation Capacitance	C_{PD} (Note 11)	-	-	45	-	pF

NOTES:

8. Limits tested at 100%.
9. 3.3V Min at 3.6V, Max at 3V.
10. 5V Min at 5.5V, Max at 4.5V
11. C_{PD} is used to determine the dynamic power consumption per gate.
 AC: $P_D = V_{CC}^2 f_i (C_{PD} + C_L)$
 ACT: $P_D = V_{CC}^2 f_i (C_{PD} + C_L) + V_{CC} \Delta I_{CC}$ where f_i = input frequency, C_L = output load capacitance, V_{CC} = supply voltage.

Burn-In Test Circuit Connections (Use DC II for F3A Burn-In and AC for Life Test)

DC	DC BURN-IN I			DC BURN-IN II		
	OPEN	GROUND	V_{CC} (6V)	OPEN	GROUND	V_{CC} (6V)
CD54AC/ACT00	3, 6, 8, 11	1, 2, 4, 5, 7, 9, 10, 12, 13	14	3, 6, 8, 11	7	1, 2, 4, 5, 9, 10, 12 - 14
AC	OPEN	GROUND	$1/2 V_{CC}$ (3V)	V_{CC} (6V)	OSCILLATOR	
					50kHz	25kHz
CD54AC/ACT00	-	7	3, 6, 8, 11	14	1, 2, 4, 5, 9, 10, 12, 13	-

NOTE: Each pin except V_{CC} and Gnd will have a resistor of $2\text{k}\Omega$ - $47\text{k}\Omega$.

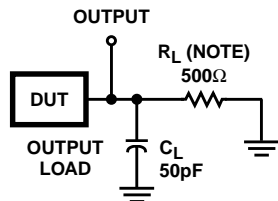

NOTE: For AC Series Only: When $V_{CC} = 1.5\text{V}$, $R_L = 1\text{k}\Omega$.

	CD54AC	CD54ACT
Input Level	V_{CC}	3V
Input Switching Voltage, V_S	$0.5 V_{CC}$	1.5V
Output Switching Voltage, V_S	$0.5 V_{CC}$	$0.5 V_{CC}$

FIGURE 1. PROPAGATION DELAY TIMES

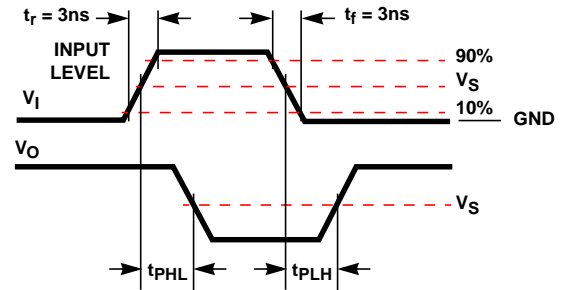

FIGURE 2. WAVEFORMS