



# 50/60 Hz Current Sensors – CS60 Series



The CS60 series is designed to measure current from 5 to 100 Arms. Applications include sensing branch circuit overload and detecting load drop or shutdown. The sensor functions as the encapsulated secondary of a current transformer, while the conductor carrying the current to be measured serves as the “one turn primary.” Sensitivity may be enhanced by increasing primary turns.

These parts are mountable on printed circuits and have a third terminal added for mechanical stability.

Samples of these and other current sensors are available for evaluation. To request samples, contact Coilcraft or visit [www.coilcraft.com](http://www.coilcraft.com).

## Typical Response

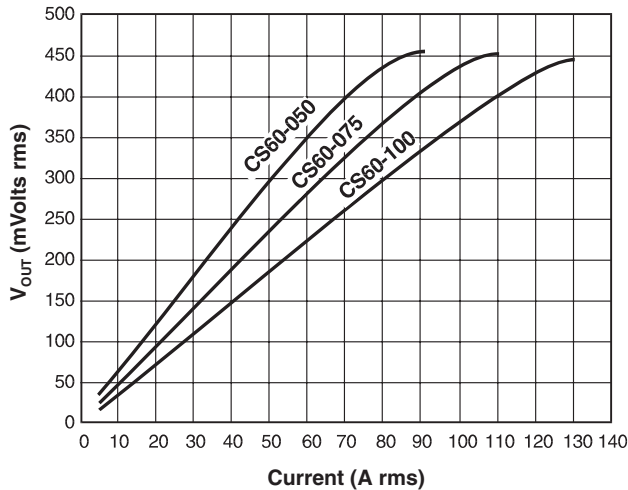

## Typical Circuit

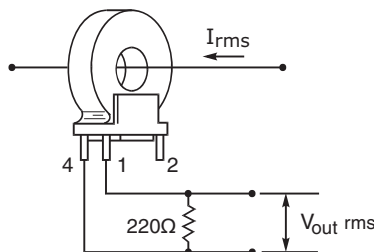

Part number	Sensed current (I <sub>rms</sub> )	V <sub>out</sub> tolerance
CS60-050L	5-50 A rms	±10%
CS60-075L	5-75 A rms	±10%
CS60-100L	5-100 A rms	±10%

(For sensed current below 10 A rms, see CS60-010 data sheet)

1. Operating temperature range -40°C to +85°C.
2. Electrical specifications at 25°C.

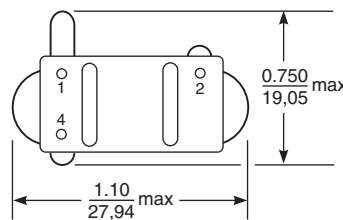
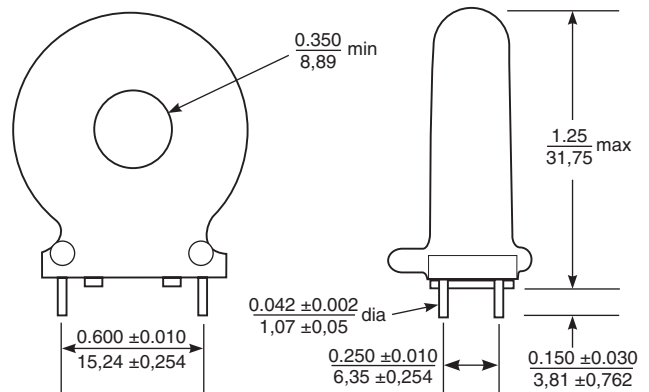

**Weight:** 13.8 – 15.4 g  
**Terminations:** Tin-silver over copper



Specifications subject to change without notice. Please check our website for latest information.

Document 134 Revised 02/01/05

1102 Silver Lake Road Cary, Illinois 60013 Phone 847/639-6400 Fax 847/639-1469

E-mail [info@coilcraft.com](mailto:info@coilcraft.com) Web <http://www.coilcraft.com>