

Low Power UHF Data Transceiver Module

UK Version - BiM-418-40
Euro Version - BiM-433-40

The BiM-418-40 and BiM-433-40 are miniature UHF radio modules capable of half duplex data transmission at speeds upto 40 Kbit/s over distances of 30 metres "in-building" and 120 metres open ground



BiM-UHF transceiver

Features

- ❖ Miniature PCB Mounting module
- ❖ Licence Exempt operation in UK on 418MHz, MPT 1340 (BiM-418-40)
- ❖ ETS 300-220 tested for European use on 433.92 MHz (BiM-433-40)
- ❖ SAW controlled FM transmission at -6dBm ERP.
- ❖ Double conversion Superhet receiver
- ❖ -107dBm receive sensitivity
- ❖ Single 4.5 to 5.5V supply < 15mA (tx or rx)
- ❖ Half duplex data at upto 40 kbit/s
- ❖ Reliable 30 metre in-building range
- ❖ Direct interface to 5V CMOS logic
- ❖ Fast 1ms power up enable for duty cycle power saving
- ❖ On board data slicer, supply switches and antenna change over.

The module integrates a low power UHF FM transmitter and matching superhet receiver together with the data recovery and TX/RX change over circuits to provide a low cost solution to implementing a Bi-directional short range radio data link. The high data rates (upto 40kbit/s) and fast TX/RX changeover (<1ms) make the BiM transceiver ideal for high integrity one to one links / multi-node packet switch networks. Rapid RX power up (<1ms) allows effective duty cycle power saving of the receiver for battery powered applications (e.g. 15µA average @ 1ms ON : 1sec OFF).

Typical applications :-

- ❖ Medium speed computer networks
- ❖ Laptop > PC > printer links
- ❖ High integrity wireless Fire / Security alarms
- ❖ Building environment control / monitoring
- ❖ Vehicle alarm systems
- ❖ Remote meter reading
- ❖ Authorisation / Access control

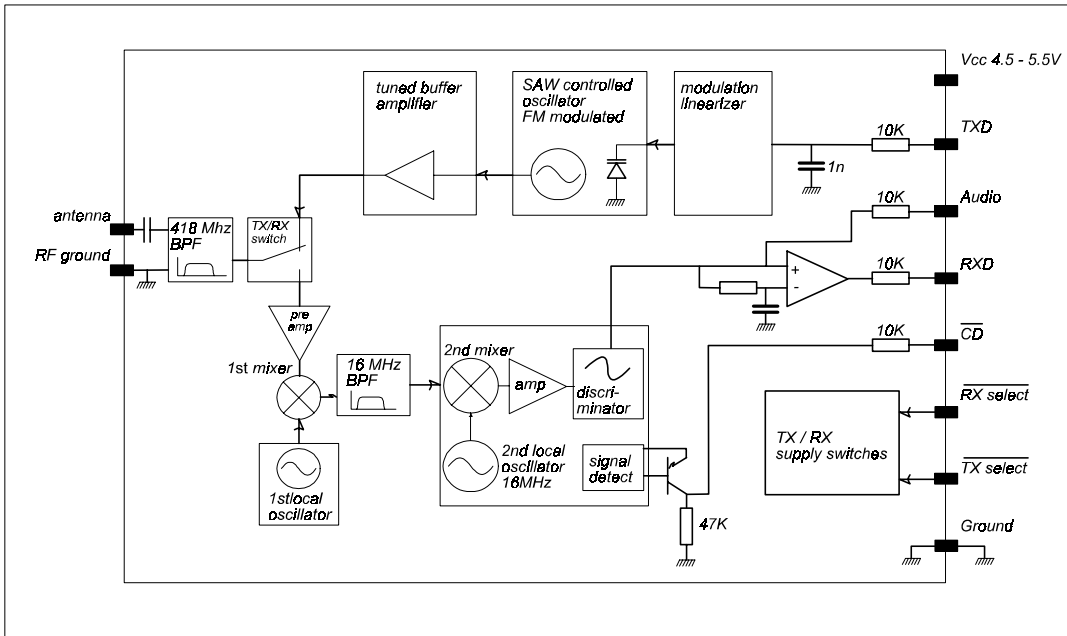

figure 1: block diagram

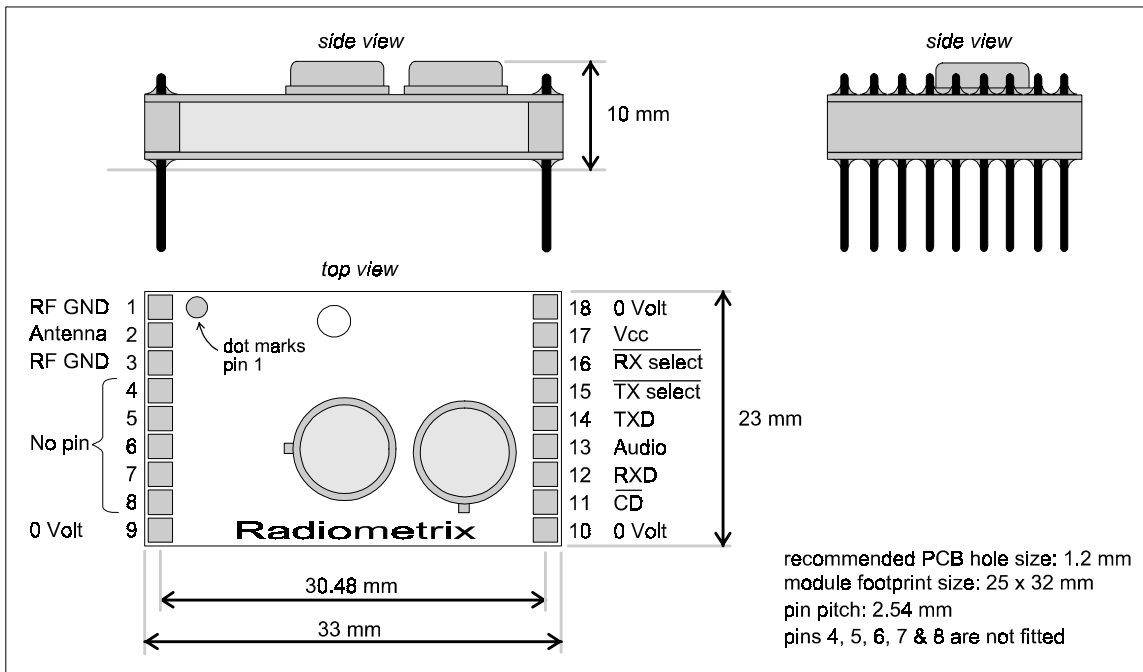

figure 2: mechanical dimensions

Pin Description

pin 1 & 3	<i>RF GND</i>	These pins should be connected to the ground plane against which the integral antenna radiates . Internally connected to pins 9,10,18 .
pin 2	<i>Antenna</i>	RF input / RF output for connection to an integral antenna. It has a nominal RF impedance of 50 Ω and is capacitively isolated from the internal circuit.
pin 9, 10, 18	<i>Vss</i>	0V connection for the modulation and supply
pin 11	<i>CD</i>	Carrier Detect - When the receiver is enabled, a low indicates a signal above the detection threshold is being received. The output is high impedance (50k Ω) and should only be used to drive a CMOS logic input.
pin 12	<i>RXD</i>	This digital output from the internal data slicer is a squared version of the signal on pin 13 (AF). This signal is used to drive external digital decoders, it is true data (i.e. as fed to the transmitters data input). The 10k Ω output impedance is suitable for driving CMOS logic. Note: this output contain squared noise when no signal is being received.
pin 13	<i>RX Audio</i>	This is the FM demodulator output. It has a standing DC bias of approximately 1.5V and may be used to drive analogue data decoders such as modems or DTMF decoders. Output impedance is 10k Ω . Signal level approx. 0.4V pk to pk. We recommend this signal always be available on a convenient test point for diagnostic purposes. Note: unlike the RXD output which is always true data, this output is true data on the BiM-418 and inverted on the BiM-433.
pin 14	<i>TXD</i>	Should be driven directly by a CMOS logic device running on the same supply voltage as the module. Analogue drive may be used but must not drive this input above Vcc or below 0V. This input should be held at <0.5V when the TX is not selected to prevent current leak (see block diagram).

pin 15 *TX select* Active low transmit / receive selects with 10kΩ internal
pin 16 *RX select* pull-ups. They may be driven by open collector or CMOS logic

All states are valid.

Pin 15 TX	Pin 16 RX	function
1	1	power down (<1μA)
1	0	receiver enabled
0	1	transmitter enabled
0	0	self test loop back

Note - loop test is at reduced TX power.

pin 17 *Vcc* positive supply, supply voltages from 4.5V to 5.5V may be used. Reverse polarity will destroy the module. Supply is internally decoupled. Maximum ripple content 50mV pk to pk.

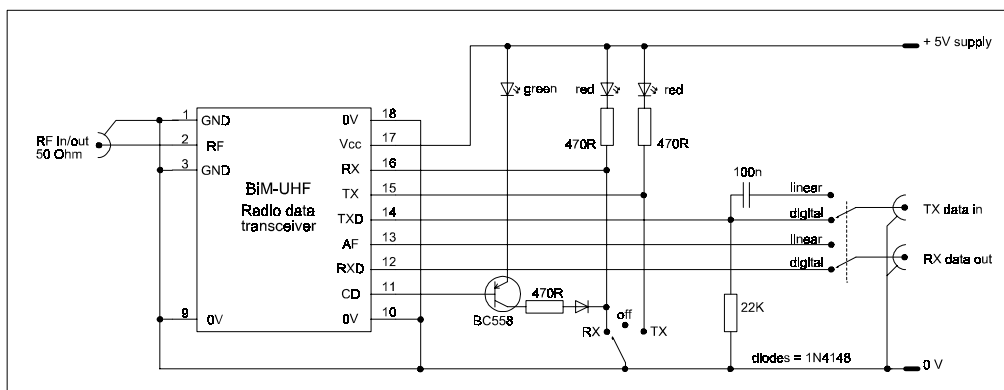

figure 3: test circuit BiM-UHF

Warning: *Don't be tempted to adjust the trimmer on the module, it controls the receive frequency and can only be correctly set-up with an accurate RF signal generator.*

Performance Data

ambient temperature: 20 °C

supply voltage: + 5.0 V, unless noted otherwise

Data applies to all frequency versions, except where noted

Parameter	Min	Typ.	Max	Units	Notes
DC parameters					
Operating supply range, <i>Vcc</i>	4.5	-	5.5	V	-
Supply current, transmit (40kbps version)	8	12	15	mA	-
Transmit (-HP version)	15	17	21	mA	-
receive	10	12	16	mA	-
loop test	-	20	25	mA	-
stand-by	-	-	1	µA	-
RF Parameters - Transmit					
Radiated power (ERP) (-40kbps version)	-10	-6	-3	dBm	1
(-HP version)	+3	+6	+10	dBm	1
Transmit frequency (Frf) BiM-418-40	-	418.000	-	MHz	-
Transmit frequency (Frf) BiM-433-40	-	433.920	-	MHz	-
Initial frequency accuracy	-75	0	+75	kHz	-
Overall frequency accuracy	-95	0	+95	kHz	-
Spurious radiation	meets ETS 300-220				
FM deviation (+/-)	15	20	30	kHz	2
Distortion	-	5	10	%	3
Modulation response @ -3dB	DC	-	32	kHz	-
RF Parameters - Receive					
Receive frequency (Frf) BiM-418-40	-	418.000	-	MHz	-
Receive frequency (Frf) BiM-433-40	-	433.920	-	MHz	-
Receiver sensitivity	-100	-107	-	dBm	-
AF bandwidth @ -3dB	0.1	-	22	kHz	-
AF output level, pin 13, pk to pk	-	400	-	mV	-
Local Oscillator leakage, pin 2	-	-57	-	dBm	-
IF Bandwidth	-	200	-	kHz	-
AFC lock range (5µV signal)	-	200	-	kHz	-
Timing					
RX select low to valid CD	-	-	1	ms	-
RX select low to valid RXD	-	-	3	ms	-
Transmit to Receive delay	-	-	1	ms	-
RF input (5µV) to valid CD	-	-	0.5	ms	-
RF input (5µV) to stable AF	-	-	0.5	ms	-

Parameter	Min	Typ.	Max	Unit	Notes
Base Band transfer function (through a pair of transceivers)					
Linear drive (4Volt pk to pk, sine)					
AF response @ -3dB	0.1	-	17	kHz	-
Analogue distortion	-	5	10	%	-
Digital drive					
Data rate (50:50)	-	-	40	kb/s	4
Time between transitions	25	-	2000	µs	5
Average Mark:Space ratio	30	50	70	%	6
preamble duration (10101010)	3	-	-	ms	-
data delay (TXD to RXD)	-	25	-	µs	-
Interface levels - inputs					
TX & RX select, <i>V high</i>	Vcc-0.5		Vcc	V	-
<i>V low</i>	0		1	V	-
Source current @ <i>V low = 0</i>	0.5		1	mA	-
TXD <i>V high</i>	Vcc-0.5		Vcc	V	-
<i>V low</i>	0		0.5	V	-
Interface levels - outputs					
RXD & CD <i>V high</i>		Vcc-0.6		V	-
(no load) <i>V low</i>		0.2		V	-

- Notes:**
1. module on 50mm square ground plane , 16cm whip antenna
 2. Standard modulation : 2kHz square wave, 0 to Vcc
 3. 1kHz, 4V pk to pk, Sinewave centred on +2.5V at pin 14 (TXD)
 4. Digital drive, 50:50 mark:space (over 4ms) data pattern.
 5. High or Low pulse.
 6. Averaged over any 4ms period

Absolute maximum ratings

Supply voltage Vcc, pin 17	-0.1	to	+6V
All input / output pins	-0.1	to	Vcc + 0.1V
Operating temperature	-20°C	to	+55°C
Storage temperature	-40°C	to	+100°C

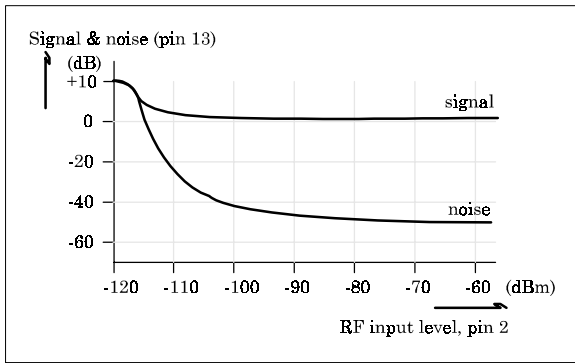

figure 4: signal to noise curve

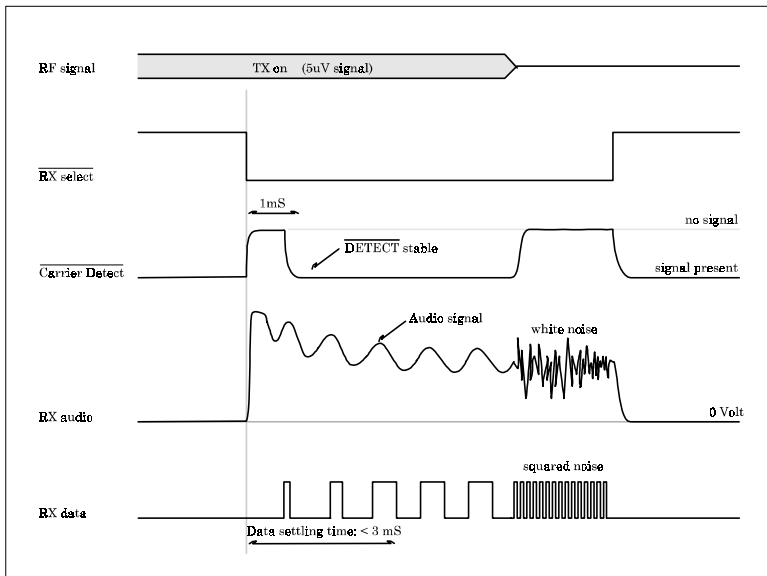

figure 5: timing waveforms

Antenna requirements

Three types of integral antenna are recommended and approved for use with the BiM transceiver :

- A) Helical: Wire coil, connected directly to pin 2, open circuit at other end. This antenna is very efficient given it's small size (20mm x 4mm dia.). The helical is a high Q antenna, trim the wire length or expand the coil for optimum results. The helical de-tunes badly with proximity to other conductive objects.
- B) Loop, A loop of PCB track tuned by a fixed or variable capacitor to ground at the 'hot' end and fed from pin 2 at a point 20% from the ground end. Loops have high immunity to proximity de-tuning.
- C) Whip This is a wire, rod ,PCB track or combination connected directly to pin 2 of the module. Optimum total length is 17cm (1/4 wave @ 418MHz) Keep the open circuit (hot) end well away from metal components to prevent serious de-tuning. Whips are ground plane sensitive and will benefit from internal 1/4 wave earthed radial(s) if the product is small and plastic cased.

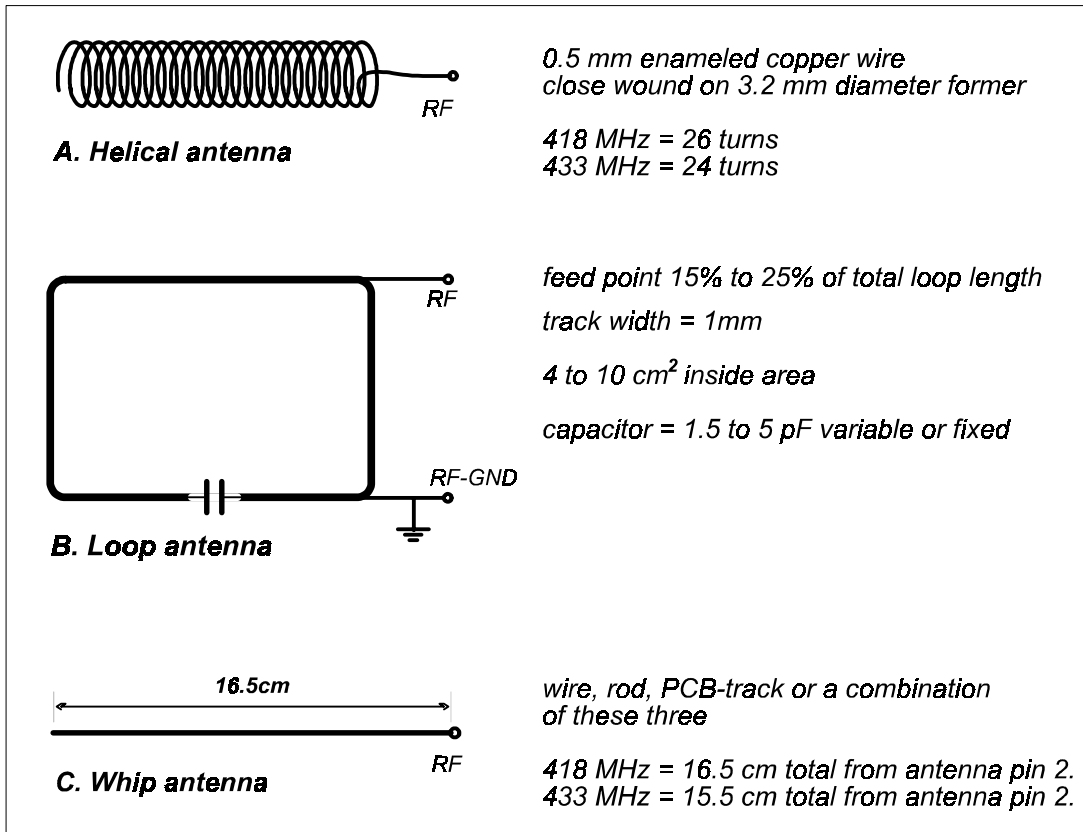

figure 6: Antenna configurations

Antenna selection chart

	A	B	C
	<i>helical</i>	<i>loop</i>	<i>whip</i>
Ultimate performance	**	*	***
Easy of design set-up	**	*	***
Size	***	**	*
Immunity proximity effects	**	***	*
Range open ground to similar antenna	80m	50m	120m

The antenna choice and position directly controls the system range. Keep it clear of other metal in the system, particularly the 'hot' end. The best position by far, is sticking out the top of the product. This is often not desirable for practical/ergonomic reasons thus a compromise may need to be reached. If an internal antenna must be used try to keep it away from other metal components, particularly large ones like transformers, batteries and PCB tracks/earth plane. The space around the antenna is as important as the antenna itself.

Type Approval

The BiM-418-40 is type approved in the UK to MPT1340 for use in Telemetry, Telecommand and In-Building alarm applications.

CONFORMANCE to MPT1340 REQUIRES THAT:

1. The transmitting antenna must be one of the 3 variants given in the data sheet. Antenna structures which yield ERP gain are not permitted.
2. The module must be directly and permanently connected to the transmitting antenna without the use of an external feeder. Increasing the RF power level by any means is not permitted.
3. The module must not be modified nor used outside it's specification limits.
4. The module may only be used to send digital or digitised data. Speech / music are not permitted.
5. The equipment in which the module is used must carry an inspection mark located on the outside of the equipment and be clearly visible. The minimum dimensions of the inspection mark shall be 10 x 15 mm and the letter and figure height must be no less than 2mm. The wording shall read: "**MPT 1340 W.T. LICENCE EXEMPT**".
6. Products intended for UK commercial application must be notified to the Radiocommunications Agency (RA) on form RA 249 (Cat I), obtainable from the RA's library service, Tel: +44 (0)171 211 0502 / 0505

OEM Manufacturers incorporating the BiM-418-F transceiver as a component part of their product are authorised by Radiometrix Ltd to quote our type-approval.

MPT 1340 is the type approval specification issued by the RA and may be obtained from the RA's library service on +44 (0)171 211 0502 / 0505.

BiM-UHF Transceiver Applications Note

Sending and Receiving Digital data

The BiM contains no data coding or decoding functions. These must be provided by the external controller, usually a single chip microprocessor, e.g. Arizona Microsystems PIC, Motorola MC68HC05 or similar. Alternatively a dedicated protocol controller such as CML's FX909 or Echelon's Network chips will work well.

The Radiometrix RPC-000-SO Radio Packet Controller IC provides all the processor intensive low-level packet formatting and data recovery functions required in a high speed bi-directional data link/network. The RPC-418-40 and RPC-433-40 provide a self-contained UHF radio port for a host micro controller. The board combines a BiM transceiver and a RPC packet controller. (Data available on request.)

A pair of BiM transceiver's will transmit direct serial data applied to the TXD input and reproduce direct serial data at the RXD output of receiving BiM. The BiM may also be used with linear data e.g. from modem IC's (see test circuit for linear biasing of TXD input).

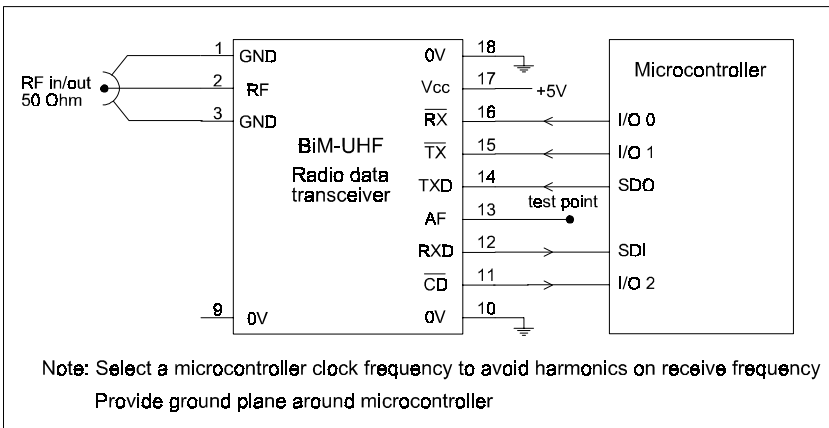

figure 7: typical microcontroller interface

Direct Digital, TXD > RXD at 5V CMOS Levels

The data path through a pair of BiM's is AC coupled. This places 3 basic constraints that any serial code must satisfy for reliable transfer.

1. Pulse width time The receiver base band bandwidth and the AC coupling determines that the time, T, between any 2 consecutive transitions in the serial code must satisfy: $25\mu\text{s} < T < 2\text{ms}$
2. RX settling time The AFC and data slicer in the receiver require at least 3ms of '10101010' preamble to be transmitted before the data at the RXD output may be considered reliable. Increasing this time to 5ms will give increased immunity to RF interference.
3. Mark/Space ratio The data slicer in the receiver is optimised for data waveforms with 50:50 Mark:Space averaged over any 4ms period. The slicer will tolerate sustained asymmetry up to 30/70 (either way), however, this will result in up to increased in pulse width distortion and a decreased noise tolerance.

Any serial data waveform satisfying the above criteria will pass reliably through a pair of BiM's.

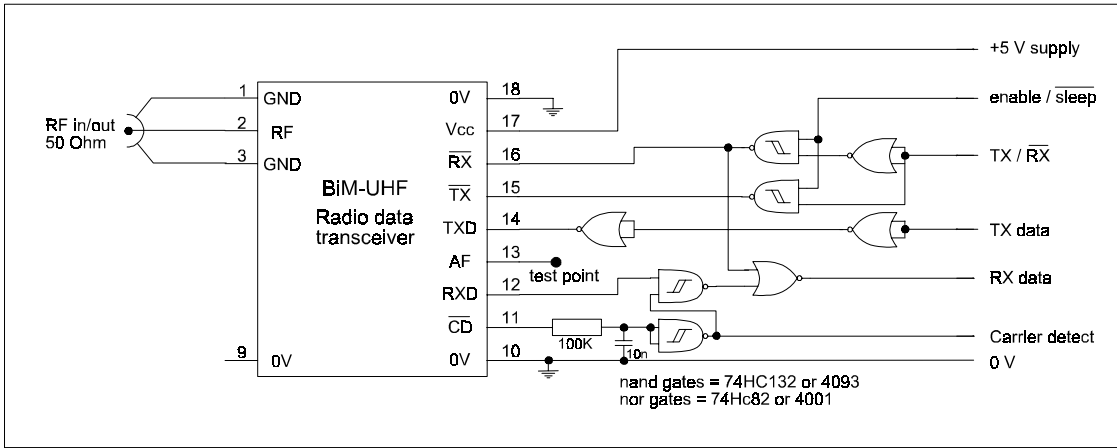

figure 8: fully buffered CMOS interface - digital drive

"RS232" Serial data

It is possible to transmit "RS232" serial data directly at 4.8 to 38.4kb/s baud between a pair of BiM transceivers in half duplex . The data must be "packetised" with no gaps between bytes. i.e. : The data must be preceded by >3ms of preamble (55h or AAh hex) to allow the data slicer in the BiM to settle, followed by 1 or 2 FFh bytes to allow the receive UART to lock, followed by a unique start of message byte, (01h), then the data bytes and finally terminated by a CRC or check sum. The receiver data slicer provides the best bit error rate performance on codes with a 50:50 mark:space average over a 4ms period, a string of FFh or 00h is a very asymmetric code and will give poor error rates where reception is marginal. Only 50:50 codes may be used at data rates above 20kbit/s.

We recommend 3 methods of improving mark:space ratio of serial codes, all 3 coding methods are suitable for transmission at 40kbit/s :-

- **Method 1 - Bit coding**

Bit rate , Max 40kbit/s , Min 250bit/s
Redundancy (per bit) 100% (Bi-phase), 200% (1/3 : 2/3)

Each bit to be sent is divided in half, the first half is the bit to be sent and the second half, it's compliment. Thus each bit has a guaranteed transition in the centre and a mark:space of 50:50 . This is Bi-phase or Manchester coding and gives good results, however the 100% redundancy will give a true throughput of 20kbit/s.

A less efficient, variation of Bi-phase is 1/3 : 2/3 bit coding. Each bit to be sent is divided into 3 parts, the first 1/3 is a low, mid 1/3 is the data bit and final 1/3 is high. This code is easy to decode since each bit always starts with a negative transition. This code should not be sent faster than 100µs per bit (10kbit/s) since the mark/space can vary for 33 to 67%.

- **Method 2 - Byte coding**

Bitrate , Max 40kbit/s , Min 2kbit/s
Redundancy (per byte) 25% (synchronous), 50% (async)

If only a subset of the ASCII code is required (e.g. 0-9 , A-Z and a few control codes) then translate (via. a look up table) the required ASCII codes into the 8 bit codes below. These codes all have a 50:50 mark/space when sent serially.

Of the 256 possible 8 bit codes, 70 contain 4 ones & 4 zeros. The 68 Hex codes below have a 50:50 mark:space and may either be sent/received from a standard serial port (UART) using 1 start, 1 stop and no parity or as bytes of a synchronous code. Use for this subset also allows simple byte error checking on reception as all received codes must contain exactly 4 one's and 4 zero's.

17	1B	1D	1E	27	2B	2D	2E	33	35	36	39	3A	3C	47	4B	4D
4E	53	55	56	59	5A	5C	63	65	66	69	6A	6C	71	72	74	78
87	8B	8D	8E	93	95	96	99	9A	9C	A3	A5	A6	A9	AA	AC	B1
B2	B4	B8	C3	C5	C6	C9	CA	CC	D1	D2	D4	D8	E1	E2	E4	E8

(note 0Fh & F0h have been omitted to minimise consecutive 0 or 1's)

Other subsets are also possible e.g. a 10bit code has 1024 differs, 252 of which have 5 one's and 5 zero's i.e. a 50:50 M:S ratio.

- **Method 3 - FEC coding**

Bit rate , Max 40kbit/s , Min 4.8kbit/s
Redundancy (per byte) 100%

Each byte is sent twice; true then it's logical compliment. e.g. even bytes are true and odd bytes are inverted. this preserves a 50:50 balance.

A refinement of this simple balancing method is to increase the stagger between the true and the inverted data streams and add parity to each byte. Thus the decoder may determine the integrity of each even byte received and on a parity failure select the subsequent inverted odd byte. The greater the stagger the higher the immunity to isolated burst errors.

Linear operation

A pair of transceivers may also be viewed as a linear analogue channel with a pass baseband of 100Hz to 17kHz with <10% distortion. The ultimate S/N ratio being >40dB (see quieting curves v RF input). The test circuit shows the TXD input biased for linear operation and a simple digital filter to shape the transmit data to a raise cosine wave shape. The 22kΩ resistor linear- biases the TXD input. The drive voltage should be between 3.5 and 5V pk to pk to achieve full modulation (greatest S/N at receiver)

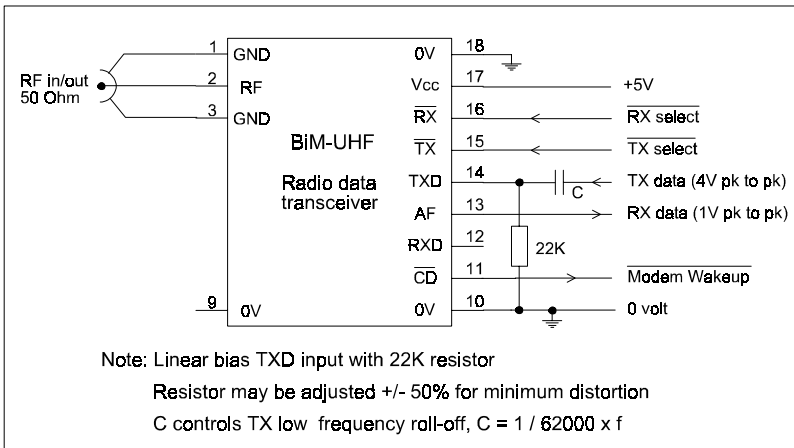

figure 9: linear drive

Raised cosine shaping may be applied externally to any serial data stream and will yield better error performance than unshaped data at high data rates (up to 40kbit/s) for data streams with 50:50 mark:space (4ms averaging period). Several excellent modem chips (FX 589 & FX 909) are available for Consumer Microcircuits Ltd (CML Tel 44 1376 513833). These chips employ GMSK (shaped data and matched receive filters) and enable operation up to 40kbit/s.

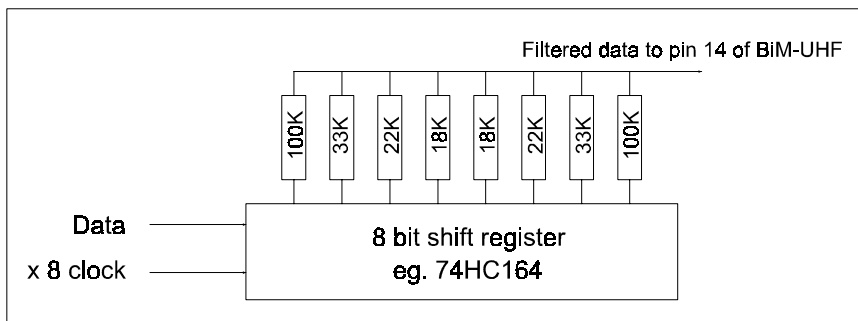

figure 10: raised cosine generator

Digitised analogue data

Linear operation of BiM transceivers will allow direct transfer of analogue data, however in many applications the distortion and low frequency roll off are too high (e.g. bio-medical data such as ECG). The use of delta modulation is an excellent solution for analogue data in the range 1Hz up to 4KHz with less than 1% distortion. A number of proprietary IC's such as Motorola's MC3517/8 provide CVSD Delta mod/demod on a single chip.

Where the signal bandwidth extends down to DC, such as strain gauges, level sensing, load cells etc. then V-F / F-V chips (such as Nat Semi LM331) provide a simple means of digitising.

Packet data

In general, data to be sent via a radio link is formed into a serial "packet" of the form :-

Preamble - Control - Address - Data - CRC

- Where: Preamble:** This is mandatory for the receiver in the BiM to stabilise. The BiM will be stable after 3ms. Additional preamble time may be desired for decoder bit sync., software carrier detection or receiver wake up.
- Control:** The minimum requirement is a single bit or unique bit pattern to indicate the start of message (frame sync.). Additionally, decoder information is often placed here such as: packet count, byte count, flow control bits (e.g. ACK, repeat count), repeater control, scrambler information etc.
- Address:** This information is used for identification purposes and would at least contain a 16/24 bit source address, additionally - destination address, site / system code , unit number and repeater address's may be placed here.
- Data:** User data , generally limited to 256 bytes or less (very long packets should be avoided to minimise repeat overheads on CRC failure and channel hogging).
- CRC:** 16/24 Bit CRC or Checksum of control-address-data fields used by the decoder to verify the integrity of the packet.

The exact makeup of the packet depends upon the system requirements and may involve some complex air-traffic density statistics to optimise through-put in large networked systems.

Networks

BiM's may be used in many different configurations from simple pair's to multi-node random access networks. The BiM is a single frequency device thus in a multi node system the signalling protocol must use Time Division Multiple Access. In a TDMA network only one transmitter may be on at a time, "clash" occurs when two or more transmitters are on at the same time and will often cause data loss at the receivers. TDMA networks may be configured in several ways - Synchronous (time slots), Polling (master-slave) or Random access (async packet switching e.g. X25). Networked BiM's allow several techniques for range / reliability enhancement:

- Store and forward Repeaters:** If the operating protocol of the network is designed to allow data path control then data may be routed "via" intermediate nodes. The inclusion of a repeating function in the network protocol either via dedicated repeater/router nodes or simply utilising existing nodes allows limitless network expansion.
- Spacial Diversity:** In buildings multi-path signals create null spots in the coverage pattern as a result of signal cancellation. In master-slave networks it is cost effective to provide 2 BiM's with separate antenna at the master station. The null spot patterns will be different for the two BiM's . This technique 'fills in' the null spots, i.e. a handshake failure on the first BiM due to a signal null is likely to succeed on the 2nd BiM.

Receiver Battery Saving

In many applications the receiver need not be always waiting for a signal (i.e. drawing 15mA). Often it is only required to turn the RX on after a transmission to receive handshake data , thereafter it may be deselected (i.e. $1\mu\text{A}$ leakage current).

In applications where a receiver needs to respond to a call, duty cycle power saving is very effective. For example selecting the receiver 3 times a second for 1ms and sampling the CD output for the presence of a signal will give an average current drain of $50\mu\text{A}$. In this example a 700ms preamble "wake up" would be used.

Interface logic

The logic control / data lines in and out of the BiM all have 10k Ω series EMC isolation resistors internal to the BiM (see BiM block diagram). We recommend that RXD and CD outputs be used only to drive CMOS logic inputs and no more than 5 cm of PCB track. Care should also be taken in the routing of the RXD , TXD , CD & AF tracking to minimise the cross talk between these high impedance lines. In some applications it is desirable to mute the continuous noise output on the RXD line when no signal is present, simple CMOS logic gating with the CD signal may be desirable.

There is a dc path of 20 k Ω from the TXD input to the internal switched TX supply.(see block diagram), it is desirable to hold TXD low whilst TX select is high (i.e. when not transmitting data).

The CD output is designed to be fast acting (1 ms), and can under conditions of weak signal or interference exhibit fast spurious pulses. It can be beneficial to drive a Schmitt trigger CMOS gate with this output and to include an additional R-C time constant between the CD output and the Schmitt input gate. The R should be 100 k Ω or greater and the additional time constant delay must be allowed for in the control software (i.e. preamble times etc.).

Signal Propagation

Three predominant effects are observed in the propagation of short range VHF / UHF signals in and around obstacles :-

1. Signal reflection: This gives rise to multiple paths between the transmitter and the receiver. Since these paths will be of different lengths, the arriving signals will have differing phases and strengths leading to signal cancellation at specific points in space. i.e. null points are observed. These nulls are physically small i.e. moving either the transmitter or receiver a few centimetres will be enough to take the signal out of the null. They are more frequent in situations of weak signal and where lots of large metal items are present, they are totally absent in open ground situations.
2. Signal shadowing: This occurs behind large sheets of metal e.g. trucks, foil backed plasterboard , steel reinforced floors etc. In such areas, signals are received predominantly by reflection from other objects. The shadow areas are of similar dimensions to the shielding object and show as areas of weaker average signal level with an increased occurrence of nulls due to multi path (see 1. above).
3. Signal absorption: Principally observed when signals pass through thick damp stone walls, the effects are similar to 2. above but there is less reflected signal.

PCB Layout and design notes:

- Leave 1mm all round module (i.e. PCB footprint area of 25x35mm)
- PCB holes - 1.2mm or socket strips
- Keep AF track away from RXD & TXD - to avoid cross talk.
- Put a test point on the AF pin for simple radio checking with a scope.
- Ground plane all unused PCB area around and under module.
- Position module and antenna as far from high speed logic and SMPS as possible
- Microprocessors with external data/address busses ALWAYS cause interference.
- Provide LED status lights on TX, RX & CD (direct or by plug on test PCB)
- For complex networks - provide software test routines for :-continuous RX, continuous TX, loop test, Simple master / slave "ping-pong".
- The BiM-can (fig. 11) is available and may be used for shielding to achieve an optimal radio performance

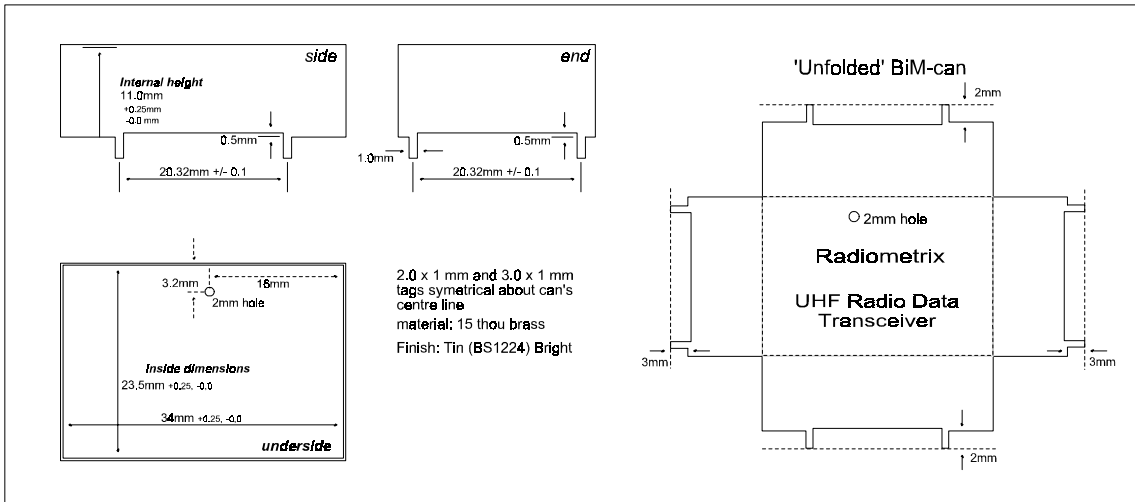

figure 11: BiM-can layout

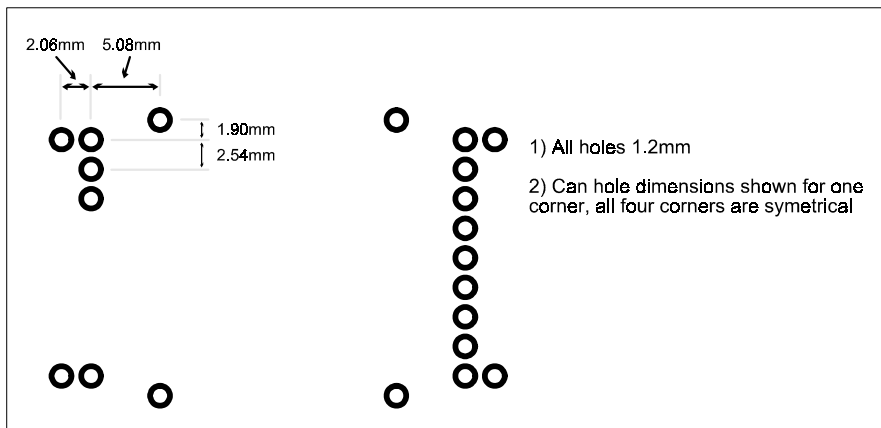

figure 12: hole pattern BiM-UHF + BiM-can

All Radiometrix's products are designed and manufactured in England.

Radiometrix Ltd

Hartcran House

Gibbs Couch

Watford

WD19 5EZ

ENGLAND

Tel: +44 (0)20 8428 1220

Fax: +44 (0)20 8428 1221

info@radiometrix.co.uk

www.radiometrix.co.uk

Copyright notice

This product data sheet is the original work and copyrighted property of Radiometrix Ltd. Reproduction in whole or in part must give clear acknowledgement to the copyright owner.

Limitation of liability

The information furnished by Radiometrix Ltd is believed to be accurate and reliable. Radiometrix Ltd reserves the right to make changes or improvements in the design, specification or manufacture of its subassembly products without notice. Radiometrix Ltd does not assume any liability arising from the application or use of any product or circuit described herein, nor for any infringements of patents or other rights of third parties which may result from the use of its products. This data sheet neither states nor implies warranty of any kind, including fitness for any particular application. These radio devices may be subject to radio interference and may not function as intended if interference is present. We do NOT recommend their use for life critical applications. The Intrastat commodity code for all our modules is: 8542 6000

R&TTE Directive

After 7 April 2001 the manufacturer can only place finished product on the market under the provisions of the R&TTE Directive. Equipment within the scope of the R&TTE Directive may demonstrate compliance to the essential requirements specified in Article 3 of the Directive, as appropriate to the particular equipment.

Further details are available on Radiocommunications Agency (RA) web site:

<http://www.radio.gov.uk/topics/conformity/conform-index.htm>

The Library and Information Service

The Radiocommunications Agency

Wyndham House

189 Marsh Wall

London

United Kingdom

E14 9SX

Tel: +44 (0)20 7211 0502/0505

Fax: +44 (0)20 7211 0507

library@ra.gsi.gov.uk

*For further information on radio matters
contact the Agency's 24 Hour Telephone*

Enquiry Point: +44 (0)20 7211 0211

European Radiocommunications Office (ERO)

Midtermolen 1

DK 2100 Copenhagen

Denmark

Tel. +45 35250300

Fax +45 35250330

ero@ero.dk

www.ero.dk