



# Signal-Line Overvoltage Protector for Low-Voltage Devices

MAX9940

www.datasheet4u.com

## General Description

The MAX9940 signal-line overvoltage protector for low-voltage digital communication ports provides protection against high-voltage faults and ESD strikes. The MAX9940 is especially useful for sensitive communication protocols such as Maxim 1-Wire<sup>®</sup> that cannot afford standard means of fault protection, such as large series resistors or large line capacitances.

The MAX9940 operates from a single supply voltage of +2.2V to +5.5V and consumes only 13 $\mu$ A of quiescent supply current. The EXT port is protected up to 28V. The device features a reaction time of 60ns for fast action during fault conditions and operates over the -40°C to +125°C automotive temperature range.

## Applications

Notebook Computers  
Portable Devices  
Industrial Equipment

## Features

- ◆ 28V Protection on EXT
- ◆ Extended ESD Protection  
±4kV IEC 61000-4 Contact on EXT
- ◆ +2.2V to +5.5V Supply Voltage Range
- ◆ 13 $\mu$ A Quiescent Supply Current
- ◆ 60ns Fault Reaction Time
- ◆ Small, 5-Pin SC70
- ◆ -40°C to +125°C Temperature Range

## Ordering Information

PART	TEMP RANGE	PIN-PACKAGE	TOP MARK
MAX9940AXK+	-40°C to +125°C	5 SC70	ATC

+Denotes a lead(Pb)-free/RoHS-compliant package.

1-Wire is a registered trademark of Maxim Integrated Products, Inc.

## Block Diagram/Typical Application Circuit

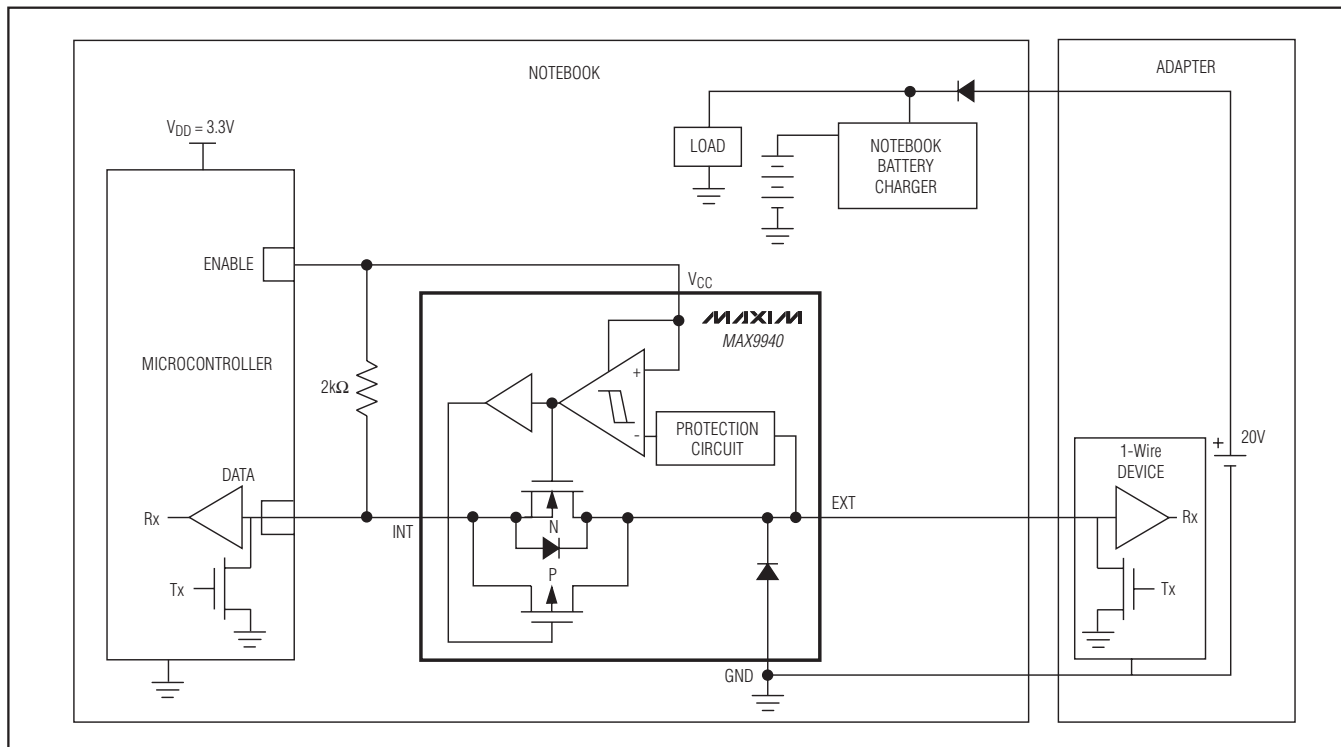

# Signal-Line Overvoltage Protector for Low-Voltage Devices

## ABSOLUTE MAXIMUM RATINGS

(All voltages with respect to GND.)

V <sub>CC</sub> .....	-0.3V to +6V
INT.....	-0.3V to +6V
EXT.....	-0.3V to +30V
Continuous Input Current into Any Terminal.....	±20mA

Continuous Power Dissipation (T<sub>A</sub> = +70°C)

5-Pin SC70 (derate 3.1mW/°C above +70°C).....	245mW
Operating Temperature Range.....	-40°C to +125°C
Junction Temperature.....	+150°C
Storage Temperature Range.....	-65°C to +150°C

Stresses beyond those listed under "Absolute Maximum Ratings" may cause permanent damage to the device. These are stress ratings only, and functional operation of the device at these or any other conditions beyond those indicated in the operational sections of the specifications is not implied. Exposure to absolute maximum rating conditions for extended periods may affect device reliability.

## ELECTRICAL CHARACTERISTICS

(V<sub>CC</sub> = +3.3V, R<sub>INT\_PULLUP</sub> = 2kΩ to V<sub>DD</sub>, V<sub>DD</sub> = 3.3V, T<sub>A</sub> = T<sub>MIN</sub> to T<sub>MAX</sub>, unless otherwise noted. Typical values are at T<sub>A</sub> = +25°C.) (Note 1)

PARAMETER	SYMBOL	CONDITIONS	MIN	TYP	MAX	UNITS
<b>POWER SUPPLY</b>						
Power-Supply Voltage	V <sub>CC</sub>		2.2		5.5	V
Quiescent Supply Current	I <sub>CC</sub>	V <sub>INT</sub> = 0		13	21	μA
<b>DC CHARACTERISTICS</b>						
INT Voltage Range	V <sub>INT</sub>		0		5.5	V
EXT Voltage Range	V <sub>EXT</sub>	(Note 2)	-0.7		+28	V
EXT Rising Threshold	V <sub>THR</sub>		V <sub>CC</sub> + 0.19	V <sub>CC</sub> + 0.26	V <sub>CC</sub> + 0.30	V
EXT Falling Threshold	V <sub>THF</sub>		V <sub>CC</sub> + 0.09	V <sub>CC</sub> + 0.13	V <sub>CC</sub> + 0.16	V
<b>SWITCH CHARACTERISTICS</b>						
On-Resistance	R <sub>ON</sub>	0 < V <sub>EXT</sub> < V <sub>CC</sub> , I <sub>EXT</sub> = ±10mA		43.5	77.5	Ω
On-Capacitance	C <sub>ON</sub>	Capacitance to GND		38		pF
INT Off-Capacitance	C <sub>OFF</sub>	Capacitance to GND		27		pF
INT Normal Operation Leakage Current (to GND)		0 < V <sub>INT</sub> < V <sub>CC</sub> , V <sub>CC</sub> = 5.5V		3	4.2	μA
EXT Normal Operation Leakage Current (to GND)		0 < V <sub>EXT</sub> < V <sub>CC</sub> , V <sub>CC</sub> = 5.5V		3	5	μA
INT Fault Leakage Current		V <sub>INT</sub> = 3.3V, V <sub>EXT</sub> = 28V		2	10	nA
EXT Fault Leakage Current		V <sub>INT</sub> = 3.3V, V <sub>EXT</sub> = 28V		341	510	μA
INT Shutdown Leakage Current (to GND)		V <sub>CC</sub> = V <sub>DD</sub> = 0, 2.2V < V <sub>DD</sub> < 5.5V, R <sub>INT_PULLUP</sub> = 2kΩ to V <sub>DD</sub>		38	70	μA
		V <sub>CC</sub> = V <sub>DD</sub> = 0		1		nA
<b>AC CHARACTERISTICS</b>						
Power-Up Delay Time	t <sub>PUP</sub>			500		μs
Fault Reaction Time	t <sub>OFF</sub>	Fault, V <sub>EXT</sub> = 10V, R <sub>INT_PULLUP</sub> = 200Ω		98	200	ns
		Fault, V <sub>EXT</sub> = 16V, R <sub>INT_PULLUP</sub> = 200Ω		60		
Fault Recovery Time	t <sub>ON</sub>	Fault removed, V <sub>EXT</sub> < V <sub>CC</sub> - 0.8V		271	375	ns

**Note 1:** All devices are 100% production tested at T<sub>A</sub> = +25°C. Specifications over temperature limits are guaranteed by design.

**Note 2:** Minimum EXT voltage of -0.7V is allowed only with a maximum drawn current of 20mA.

# Signal-Line Overvoltage Protector for Low-Voltage Devices

MAX9940

www.datasheet4u.com

## Typical Operating Characteristics

( $V_{CC} = +3.3V$ ,  $R_{INT\_PULLUP} = 2k\Omega$  to  $V_{DD}$ ,  $V_{DD} = 3.3V$ ,  $T_A = T_{MIN}$  to  $T_{MAX}$ , unless otherwise noted.)

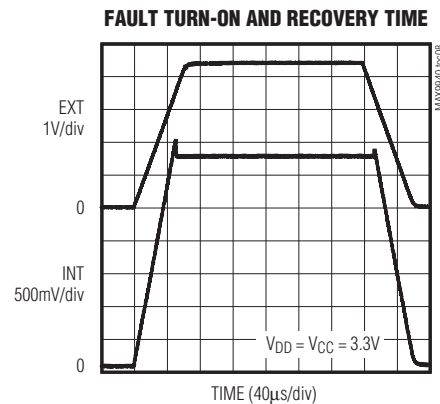
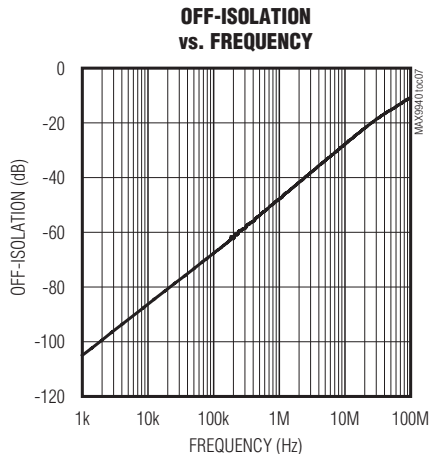
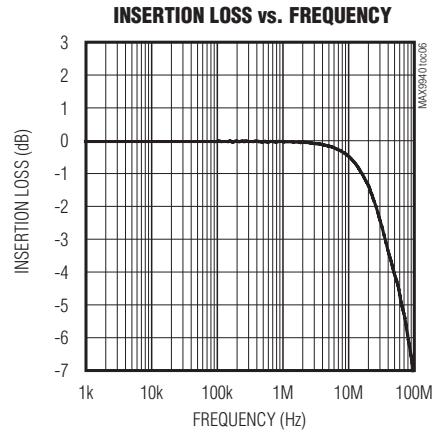
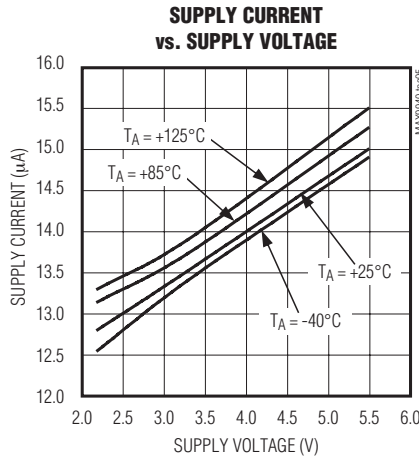
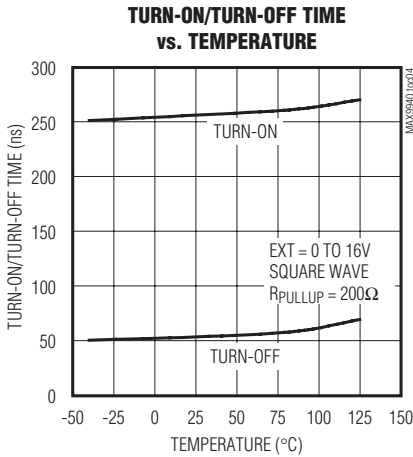
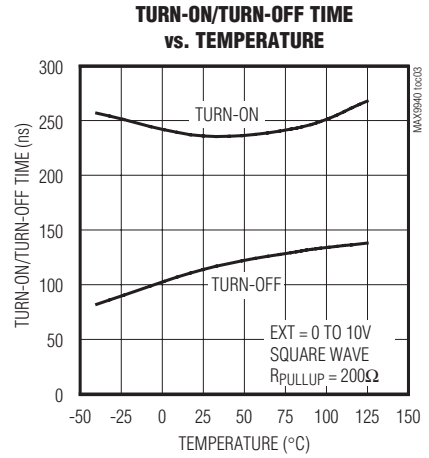
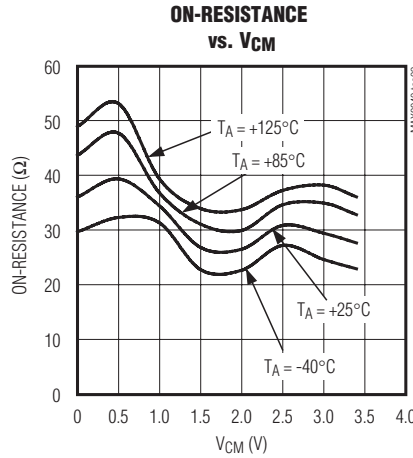
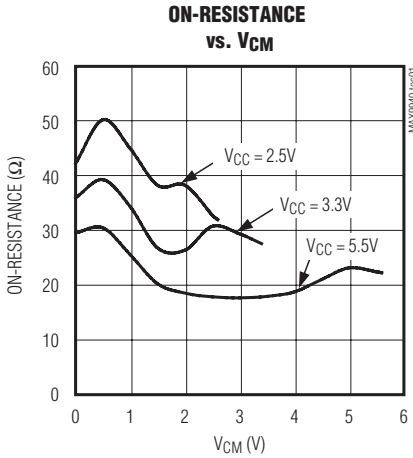

# Signal-Line Overvoltage Protector for Low-Voltage Devices

## Typical Operating Characteristics (continued)

( $V_{CC} = +3.3V$ ,  $R_{INT\_PULLUP} = 2k\Omega$  to  $V_{DD}$ ,  $V_{DD} = 3.3V$ ,  $T_A = T_{MIN}$  to  $T_{MAX}$ , unless otherwise noted.)

**FAULT TURN-ON TIME**

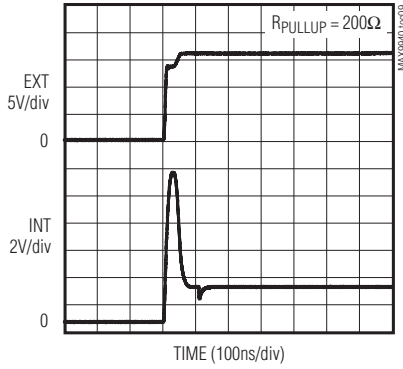

**FAULT RECOVERY TIME**

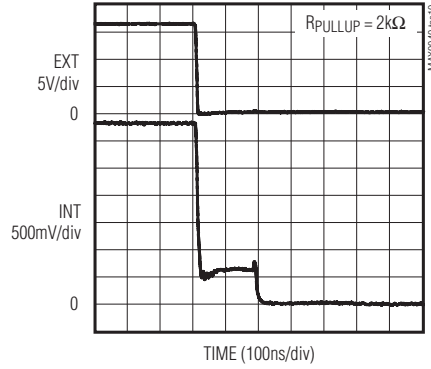

**FAULT TURN-ON AND RECOVERY TIME (SCHOTTKY DIODE FROM INT TO  $V_{CC}$ )**

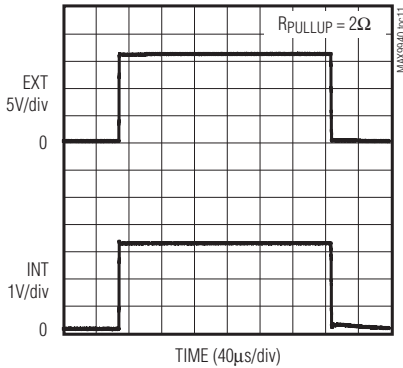

**FAULT TURN-ON TIME (SCHOTTKY DIODE FROM INT TO  $V_{CC}$ )**

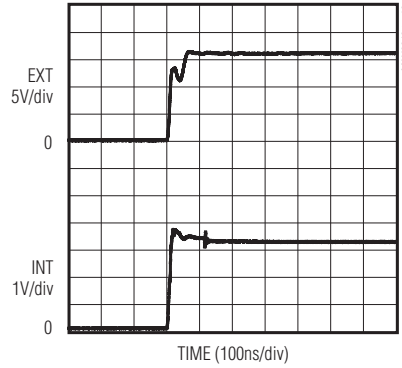

**$V_{THR}$  AND  $V_{THF}$  vs. SUPPLY VOLTAGE**

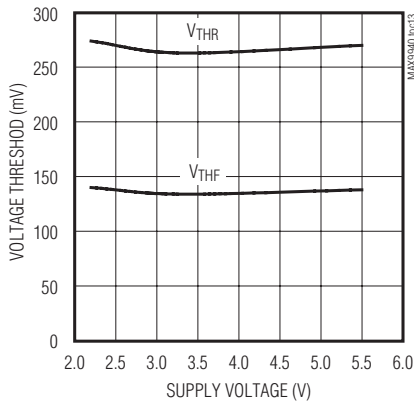

**$V_{THR}$  AND  $V_{THF}$  vs. TEMPERATURE**

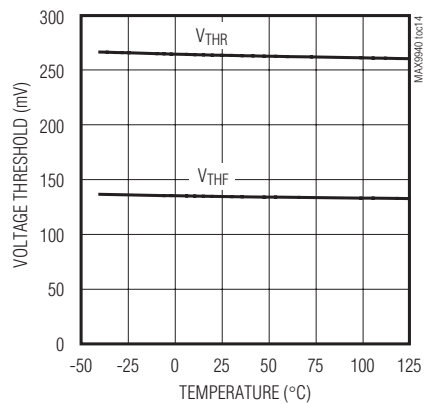

# Signal-Line Overvoltage Protector for Low-Voltage Devices

www.datasheet4u.com

## Pin Description

PIN	NAME	FUNCTION
1	V <sub>CC</sub>	Power Supply. Can be connected to a microcontroller enable input.
2	GND	Ground
3	N.C.	No Connection. Not internally connected.
4	INT	Microcontroller I/O Port. Connection to a microcontroller data port.
5	EXT	External Connector Port. Connection to a 1-Wire device.

MAX9940

## Detailed Description

The MAX9940 is a signal-line overvoltage protector for low-voltage devices that provides circuit protection from high-voltage faults and ESD strikes. The device provides protection in digital communication lines such as 1-Wire and I<sup>2</sup>C protocols where large series resistance and capacitances cannot be used to provide protection due to their impact on V<sub>IL</sub>/V<sub>IH</sub> levels and communication timing. The MAX9940 includes a series switch that connects INT to EXT. When a high-voltage fault condition occurs on EXT, the MAX9940 quickly shuts off the series switch and isolates the low-voltage device from the fault condition. In addition to providing DC fault isolation, the MAX9940 also provides up to ±4kV IEC 61000-4 contact ESD protection on EXT. The MAX9940 is ideal for circuits that require low-voltage devices that communicate to the outside world over connector ports that can expose them to hazardous high-voltage DC faults and ESD strikes.

## Series Switch

The MAX9940 features a series switch to connect a low-voltage device such as a microcontroller to an external communication device such as a 1-Wire or I<sup>2</sup>C slave. The internal switch is turned off when disabled or if a fault condition exists, isolating the microcontroller from any possible damage. The nominal switch resistance is 38Ω (typ). The series switch is composed of parallel DMOS and HV-pMOS devices as shown in the

*Block Diagram/Typical Application Circuit.* The series switch cell contains circuitry that ensures the pMOS device turns off properly when the voltage at EXT exceeds the supply voltage. The switch can withstand a maximum voltage of 28V at EXT.

## Comparator

The MAX9940 features a low-power, high-speed comparator that is used to turn off the series switch if a high-voltage condition is detected on EXT. The nominal hysteresis of the comparator is 128mV (typical). Fault voltages on EXT that are slightly above V<sub>CC</sub> trigger the comparator to quickly isolate INT and EXT channels from each other. In this mode, the MAX9940 is able to withstand 28V on EXT. Negative voltages on EXT are allowed as long as they are current-limited to less than 20mA.

## Typical Application Circuits

The innovative design of the MAX9940 allows it to withstand large DC voltages up to 28V at INT and EXT even when V<sub>CC</sub> is 0. This allows application-specific power-saving and fault-protection schemes to be implemented.

Figures 1 and 2 show two methods of powering the MAX9940 from an ENABLE digital output port of the microcontroller. Figure 3 shows the conventional method of operating the MAX9940 with both pullup resistor for digital communication on DATA (RP) and V<sub>CC</sub> being connected directly to V<sub>DD</sub> of the microcontroller.

# Signal-Line Overvoltage Protector for Low-Voltage Devices

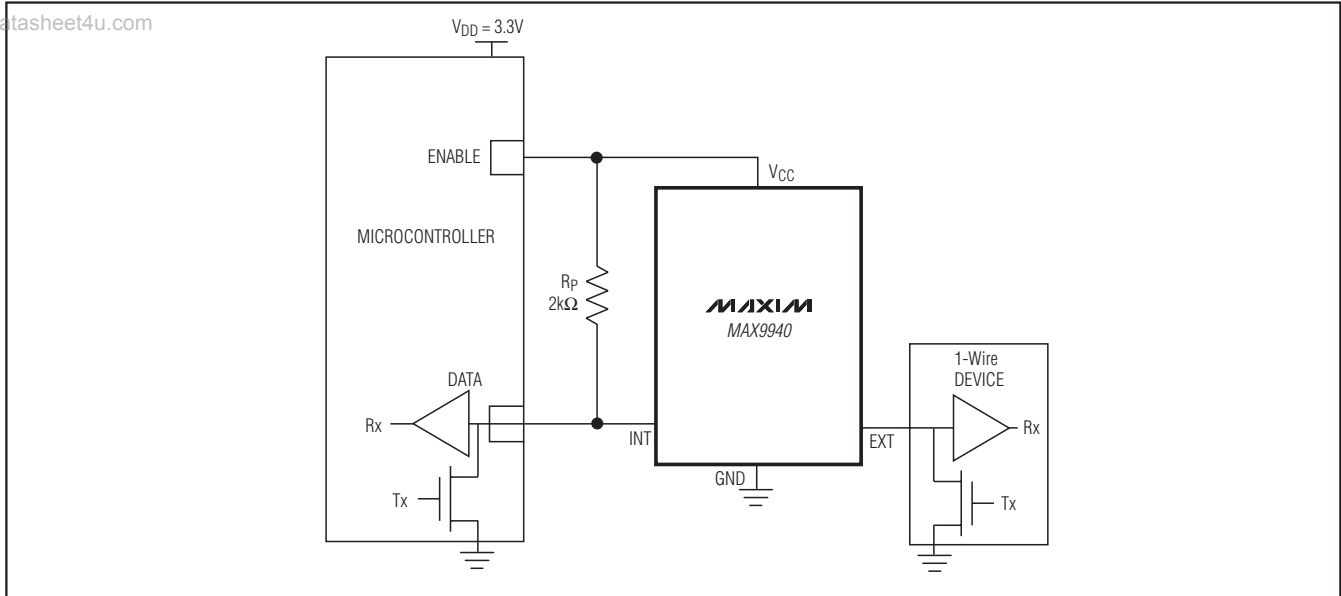

Figure 1. Recommended Scheme for Battery-Operated Devices that Need to Shut Down the MAX9940 and Prevent Power Draw During Short to GND Faults

In all three schemes, the MAX9940 protects the microcontroller from both DC fault voltages above  $V_{CC}$  and ESD strikes on EXT. The difference in the three schemes lies in the impact on power consumption in battery-operated devices during normal and short to GND conditions.

Figure 1 shows a recommended configuration for battery-operated devices that need to conserve power both on a continuous basis as well as during short to GND fault conditions. In this scheme, the ENABLE port of a microcontroller supplies the quiescent current for the MAX9940 as well as that required for digital communication (i.e.,  $R_p$  pullup resistor). By forcing a 0 on the ENABLE digital output port of the microcontroller, the MAX9940 is in a zero-power shutdown mode, while also preventing any power drain to occur in the event of a short to GND fault on EXT. As stated earlier, EXT maintains the ability to withstand DC voltages up to 28V even when  $V_{CC} = 0$ .

In Figure 2, the ENABLE port of a microcontroller powers the MAX9940. The low  $13\mu\text{A}$  operating current allows standard digital I/O ports to easily supply the

operating current of the MAX9940 without any substantial voltage drop ( $V_{OH} \approx V_{DD}$ ). By forcing a 0 on the ENABLE port of the microcontroller, the MAX9940 can be put into a zero-power mode, thus conserving battery power. It should be noted that there is no internal ESD diode from INT to  $V_{CC}$ . This allows the voltage at INT to stay at  $V_{DD}$  even though  $V_{CC} = 0$ , thus drawing no current from  $R_p$  or the battery. However, an internal diode does exist from INT to EXT, and therefore, in the event of a short to GND fault on EXT, current is drawn through  $R_p$ , causing a power drain from  $V_{DD}$ , and can potentially reduce battery life.

In Figure 3,  $V_{DD}$  powers the MAX9940 directly, and consumes quiescent current on a continuous basis. In this mode, the internal FET between INT and EXT is kept on as long as the voltage on EXT is below  $V_{CC}$ . As a result, in the event of a short to GND fault on EXT, current is drawn through  $R_p$ , causing a power drain from  $V_{DD}$  and potentially reducing battery life.

# Signal-Line Overvoltage Protector for Low-Voltage Devices

MAX9940

www.datasheet4u.com

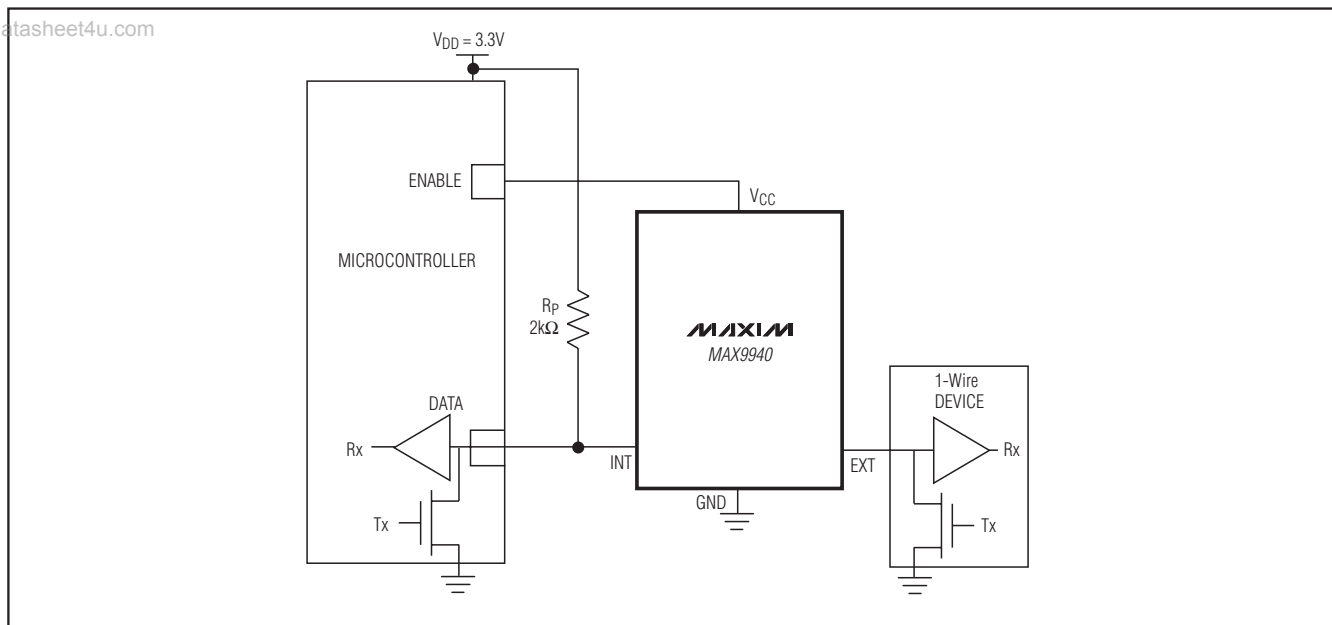

Figure 2. Recommended Scheme for Applications that Require the MAX9940 to be Put into Shutdown

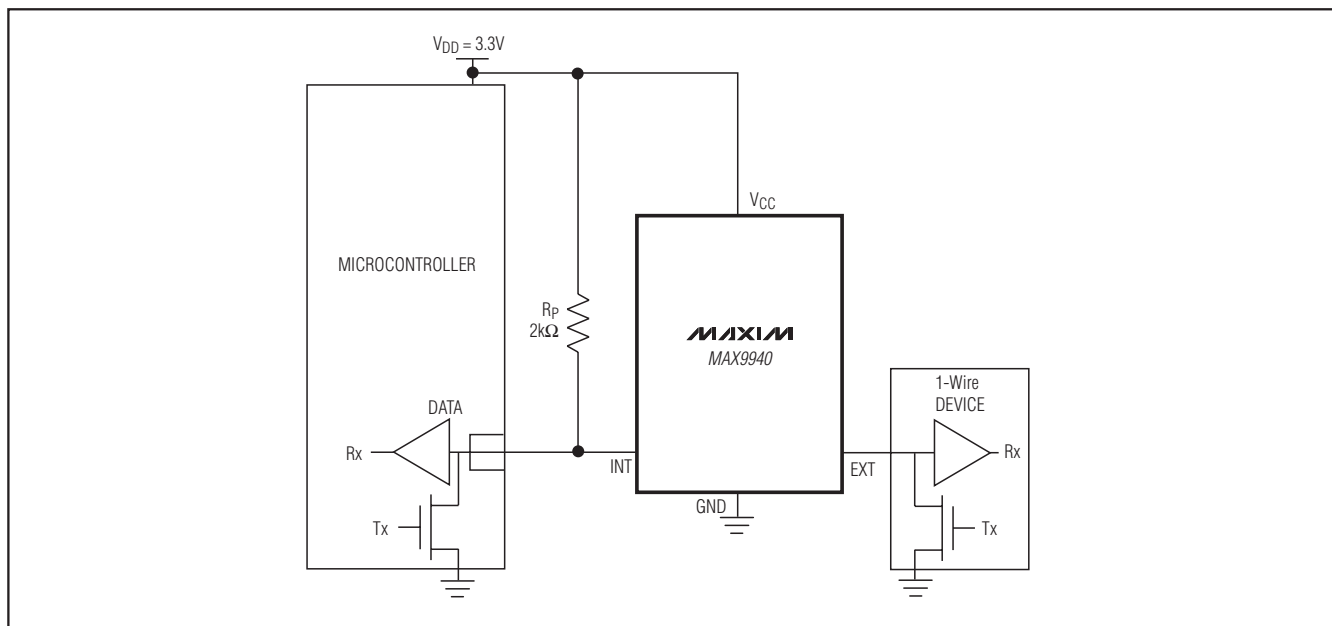
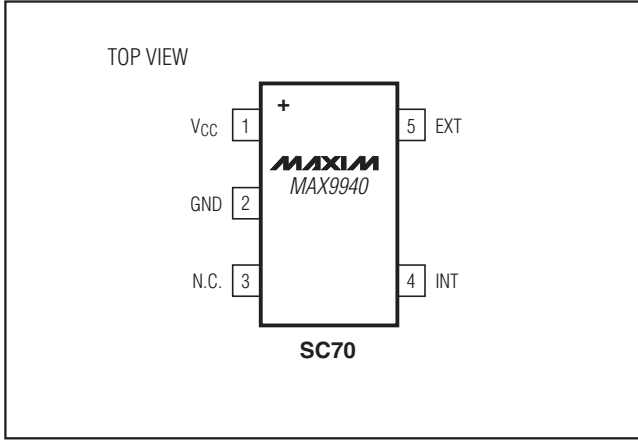

Figure 3. Recommended Operating Circuit for Nonbattery-Operated Applications

# Signal-Line Overvoltage Protector for Low-Voltage Devices

## Pin Configuration



## Chip Information

PROCESS: BiCMOS



# Signal-Line Overvoltage Protector for Low-Voltage Devices

www.datasheet4u.com

## Package Information

For the latest package outline information and land patterns, go to [www.maxim-ic.com/packages](http://www.maxim-ic.com/packages).

PACKAGE TYPE	PACKAGE CODE	DOCUMENT NO.
5 SC70	X5-1	<a href="#">21-0076</a>

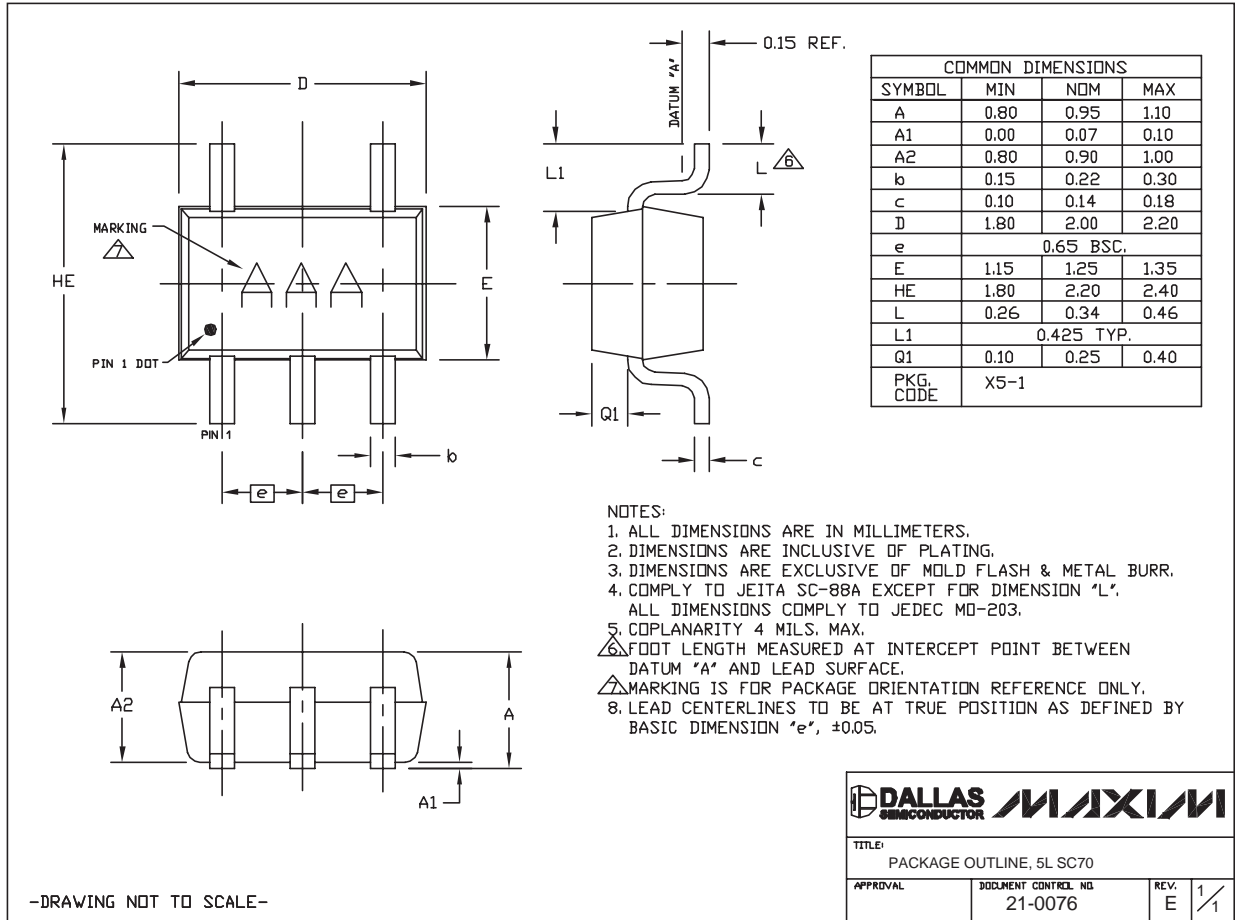

SC70, 5LEPS

MAX9940

**DALLAS SEMICONDUCTOR** **MAXIM**

TITLE:  
PACKAGE OUTLINE, 5L SC70

APPROVAL	DOCUMENT CONTROL NO. 21-0076	REV. E	1/1
----------	---------------------------------	-----------	-----

Maxim cannot assume responsibility for use of any circuitry other than circuitry entirely embodied in a Maxim product. No circuit patent licenses are implied. Maxim reserves the right to change the circuitry and specifications without notice at any time.

Maxim Integrated Products, 120 San Gabriel Drive, Sunnyvale, CA 94086 408-737-7600 \_\_\_\_\_ 9