

MAXIM

+3V Voltage Monitoring, Low-Cost, μ P Supervisory Circuits

General Description

The MAX706P/R/S/T and MAX708R/S/T microprocessor (μ P) supervisory circuits reduce the complexity and number of components required to monitor +3V power-supply levels in +3V to +5V μ P systems. These devices significantly improve system reliability and accuracy compared to separate ICs or discrete components.

The MAX706P/R/S/T supervisory circuits provide the following four functions:

- 1) A reset output during power-up, power-down, and brownout conditions.
- 2) An independent watchdog output that goes low if the watchdog input has not been toggled within 1.6sec.
- 3) A 1.25V threshold detector for power-fail warning, low-battery detection, or for monitoring a power supply other than the main supply.
- 4) An active-low manual-reset input.

The only difference between the MAX706R, MAX706S, and MAX706T is the reset-threshold voltage levels, which are 2.63V, 2.93V, and 3.08V, respectively. All have active-low reset output signals. The MAX706P is identical to the MAX706R, except its reset output signal is active-high.

The MAX708R/S/T provide the same functions as the MAX706R/S/T, except they do not have a watchdog timer. Instead, they provide both RESET and RESETE outputs. As with the MAX706, devices with R, S, and T suffixes have reset thresholds of 2.63V, 2.93V and 3.08V, respectively.

All seven devices are offered in 8-pin SO, DIP, and μ MAX packages.

Applications

Battery-Powered Equipment
Portable Instruments
Computers
Controllers
Intelligent Instruments
Critical μ P Power Monitoring

Typical Operating Circuits

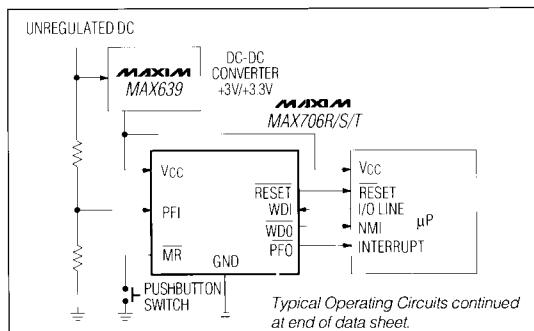

Features

- ◆ μ MAX Package: Smallest 8-Pin SO
- ◆ Precision Supply-Voltage Monitor
2.63V (MAX706P/R, MAX708R)
2.93V (MAX706S, MAX708S)
3.08V (MAX706T, MAX708T)
- ◆ 200ms Reset Time Delay
- ◆ Debounced TTL/CMOS-Compatible Manual-Reset Input
- ◆ 100 μ A Quiescent Current
- ◆ Watchdog Timer (MAX706P/R/S/T only):
1.6sec Timeout
- ◆ Reset Output Signal:
Active-High Only (MAX706P)
Active-Low Only (MAX706R/S/T)
Active-High and Active-Low (MAX708R/S/T)
- ◆ Voltage Monitor for Power-Fail or Low-Battery Warning
- ◆ 8-Pin Surface-Mount Package
- ◆ Guaranteed RESET Assertion to VCC = 1V

Ordering Information

| PART | TEMP. RANGE | PIN-PACKAGE |
|------------|-----------------|---------------|
| MAX706PCPA | 0°C to +70°C | 8 Plastic DIP |
| MAX706PCSA | 0°C to +70°C | 8 SO |
| MAX706PCUA | 0°C to +70°C | 8 μ MAX |
| MAX706PEPA | -40°C to +85°C | 8 Plastic DIP |
| MAX706PESA | -40°C to +85°C | 8 SO |
| MAX706PMJA | -55°C to +125°C | 8 CERDIP* |

Ordering Information continued at end of data sheet.

* Contact factory for availability and processing to MIL-STD-883.

Pin Configurations

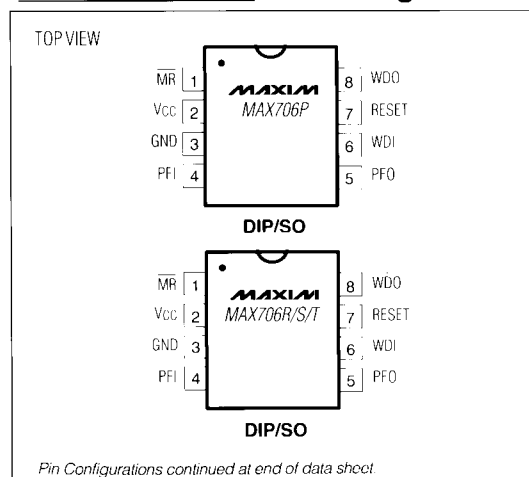

MAXIM

Maxim Integrated Products 1

Call toll free 1-800-998-8800 for free samples or literature.

MAX706P/R/S/T, MAX708R/S/T

+3V Voltage Monitoring, Low-Cost, μ P Supervisory Circuits

ABSOLUTE MAXIMUM RATINGS

| | | | |
|---|-----------------------------------|--|-----------------|
| Terminal Voltage (with respect to GND) | | μ MAX (derate 4.1mW/°C above +70°C)..... | 330mW |
| V _{CC} | -0.3V to 6.0V | CERDIP (derate 8.00mW/°C above +70°C)..... | 640mW |
| All Other Inputs (Note 1)..... | -0.3V to (V _{CC} + 0.3V) | Operating Temperature Ranges: | |
| Input Current | | MAX70_C..... | 0°C to +70°C |
| V _{CC} | 20mA | MAX70_E..... | -40°C to +85°C |
| GND..... | 20mA | MAX70_M..... | -55°C to +125°C |
| Output Current (all outputs)..... | 20mA | Storage Temperature Range..... | -65°C to +160°C |
| Continuous Power Dissipation | | Lead Temperature (soldering, 10sec)..... | +390°C |
| Plastic DIP (derate 9.09mW/°C above +70°C)..... | 727mW | | |
| SO (derate 5.88mW/°C above +70°C)..... | 471mW | | |

Note 1: The input voltage limits on PFI, WDI and \overline{MR} can be exceeded if the input current is less than 10mA.

Stresses beyond those listed under "Absolute Maximum Ratings" may cause permanent damage to the device. These are stress ratings only, and functional operation of the device at these or any other conditions beyond those indicated in the operational sections of the specifications is not implied. Exposure to absolute maximum rating conditions for extended periods may affect device reliability.

ELECTRICAL CHARACTERISTICS

(MAX70_P/R: V_{CC} = 2.70V to 5.5V, MAX70_S: V_{CC} = 3.00V to 5.5V, MAX70_T: V_{CC} = 3.15V to 5.5V, T_A = T_{MIN} to T_{MAX}, unless otherwise noted.)

| PARAMETER | SYMBOL | CONDITIONS | MIN | TYP | MAX | UNITS | |
|-------------------------------------|---------------------|--|--|---------------------------|-----------------------|-------|---------|
| Operating Voltage Range | V _{CC} | MAX70_C | 1.0 | | 5.5 | V | |
| | | MAX70_E/M | 1.2 | | 5.5 | | |
| Supply Current | I _{SUPPLY} | V _{CC} < 3.6V | MAX706_C | | 90 | 200 | μ A |
| | | | MAX706_E/M | | 90 | 300 | |
| | | | MAX708_C | | 50 | 200 | |
| | | | MAX708_E/M | | 50 | 300 | |
| | | V _{CC} < 5.5V | MAX706_C | | 135 | 350 | |
| | | | MAX706_E/M | | 135 | 500 | |
| | | | MAX708_C | | 65 | 350 | |
| | | | MAX708_E/M | | 65 | 500 | |
| Reset Threshold (Note 2) | V _{RST} | MAX70_P/R | 2.55 | 2.63 | 2.70 | V | |
| | | MAX70_S | 2.85 | 2.93 | 3.00 | | |
| | | MAX70_T | 3.00 | 3.08 | 3.15 | | |
| Reset Threshold Hysteresis (Note 2) | | | | 20 | | mV | |
| Reset Pulse Width (Note 2) | t _{RST} | MAX70_P/R: V _{CC} = 3.0V; MAX70_S/T: V _{CC} = 3.3V | 140 | 200 | 280 | ms | |
| | | V _{CC} = 5.0V | | 200 | | | |
| RESET Output Voltage (MAX70_R/S/T) | V _{OH} | V _{RST} (max) < V _{CC} < 3.6V | I _{SOURCE} = 500 μ A | 0.8 x V _{CC} | | V | |
| | V _{OL} | | | I _{SINK} = 1.2mA | 0.3 | | |
| | V _{OH} | 4.5V < V _{CC} < 5.5V | I _{SOURCE} = 800 μ A | | V _{CC} - 1.5 | | |
| | V _{OL} | | | I _{SINK} = 3.2mA | 0.4 | | |
| | V _{OL} | MAX70_C: V _{CC} = 1.0V, I _{SINK} = 50 μ A | 0.3 | | | | |
| | | | MAX70_E/M: V _{CC} = 1.2V, I _{SINK} = 100 μ A | 0.3 | | | |
| RESET Output Voltage (MAX706P) | V _{OH} | V _{RST} (max) < V _{CC} < 3.6V | I _{SOURCE} = 215 μ A | V _{CC} - 0.6 | | V | |
| | V _{OL} | | | I _{SINK} = 1.2mA | 0.3 | | |
| | V _{OH} | 4.5V < V _{CC} < 5.5V | I _{SOURCE} = 800 μ A | | V _{CC} - 1.5 | | |
| | V _{OL} | | | I _{SINK} = 3.2mA | 0.4 | | |

+3V Voltage Monitoring, Low-Cost, μ P Supervisory Circuits

ELECTRICAL CHARACTERISTICS (continued)

(MAX70_P/R: $V_{CC} = 2.70V$ to $5.5V$, MAX70_S: $V_{CC} = 3.00V$ to $5.5V$, MAX70_T: $V_{CC} = 3.15V$ to $5.5V$, $T_A = T_{MIN}$ to T_{MAX} , unless otherwise noted.)

| PARAMETER | SYMBOL | CONDITIONS | | MIN | TYP | MAX | UNITS |
|-----------------------------------|----------|---|---------------------------------|---------------------|------|------|---------|
| RESET Output Voltage (MAX708_) | V_{OH} | $V_{RST}(\max) < V_{CC} < 3.6V$ | $I_{SOURCE} = 500\mu A$ | $0.8 \times V_{CC}$ | | | V |
| | V_{OL} | | $I_{SINK} = 500\mu A$ | | | | |
| | V_{OH} | $4.5V < V_{CC} < 5.5V$ | $I_{SOURCE} = 800\mu A$ | $V_{CC} - 1.5$ | | | |
| | V_{OL} | | $I_{SINK} = 1.2mA$ | | | | |
| Watchdog Timeout Period (MAX706_) | t_{WD} | MAX70_P/R: $V_{CC} = 3.0V$; MAX70_S/T: $V_{CC} = 3.3V$ | | 1.0 | 1.6 | 2.25 | sec |
| WDI Pulse Width (MAX706_) | t_{WP} | $V_{IL} = 0.4V$, $V_{IH} = 0.8 \times V_{CC}$ | $V_{RST}(\max) < V_{CC} < 3.6V$ | 100 | | | ns |
| | | | $4.5V < V_{CC} < 5.5V$ | 50 | | | |
| WDI Input Threshold (MAX706_) | V_{IL} | $V_{RST}(\max) < V_{CC} < 3.6V$ | Low | $0.7 \times V_{CC}$ | | | V |
| | V_{IH} | | High | | | | |
| | V_{IL} | $V_{CC} = 5.0V$ | Low | | | | |
| | V_{IH} | | High | | | | |
| WDI Input Current (MAX706_) | | $WDI = 0V$ or V_{CC} | | -1.0 | 0.02 | 1.0 | μA |
| WDO Output Voltage (MAX706_) | V_{OH} | $V_{RST}(\max) < V_{CC} < 3.6V$ | $I_{SOURCE} = 500\mu A$ | $0.8 \times V_{CC}$ | | | V |
| | V_{OL} | | $I_{SINK} = 500\mu A$ | | | | |
| | V_{OH} | $4.5V < V_{CC} < 5.5V$ | $I_{SOURCE} = 800\mu A$ | $V_{CC} - 1.5$ | | | |
| | V_{OL} | | $I_{SINK} = 1.2mA$ | | | | |
| \overline{MR} Pull-Up Current | | $\overline{MR} = 0V$ | $V_{RST}(\max) < V_{CC} < 3.6V$ | 25 | 70 | 250 | μA |
| | | | $4.5V < V_{CC} < 5.5V$ | 100 | 250 | 600 | |
| \overline{MR} Pulse Width | t_{MR} | $V_{RST}(\max) < V_{CC} < 3.6V$ | | 500 | | | ns |
| | | $4.5V < V_{CC} < 5.5V$ | | 150 | | | |
| MR Input Threshold | V_{IL} | $V_{RST}(\max) < V_{CC} < 3.6V$ | Low | $0.7 \times V_{CC}$ | | | V |
| | V_{IH} | | High | | | | |
| | V_{IL} | $4.5V < V_{CC} < 5.5V$ | Low | | | | |
| | V_{IH} | | High | | | | |
| MR to Reset Out Delay (Note 2) | t_{MD} | $V_{RST}(\max) < V_{CC} < 3.6V$ | | | | 750 | ns |
| | | $4.5V < V_{CC} < 5.5V$ | | | | 250 | |
| PFI Input Threshold | | MAX70_P/R: $V_{CC} = 3.0V$; MAX70_S/T: $V_{CC} = 3.3V$, PFI falling | | 1.20 | 1.25 | 1.30 | V |
| PFI Input Current | | | | -25 | 0.01 | 25 | nA |
| PFO Output Voltage | V_{OH} | $V_{RST}(\max) < V_{CC} < 3.6V$ | $I_{SOURCE} = 500\mu A$ | $0.8 \times V_{CC}$ | | | V |
| | V_{OL} | | $I_{SINK} = 1.2mA$ | | | | |
| | V_{OH} | $4.5V < V_{CC} < 5.5V$ | $I_{SOURCE} = 800\mu A$ | $V_{CC} - 1.5$ | | | |
| | V_{OL} | | $I_{SINK} = 3.2mA$ | | | | |

Note 2: Applies to both \overline{RESET} in the MAX70_R/S/T, and RESET in the MAX706P and MAX708R/S/T.

MAX706P/R/S/T, MAX708R/S/T

+3V Voltage Monitoring, Low-Cost, μ P Supervisory Circuits

Typical Operating Characteristics

**RESET, $\overline{\text{RESET}}$ OUTPUT VOLTAGES
vs. SUPPLY VOLTAGE
(RESET OUTPUTS AND RESET THRESHOLDS
SHOWN FOR MAX708T, $T_A = +25^\circ\text{C}$)**

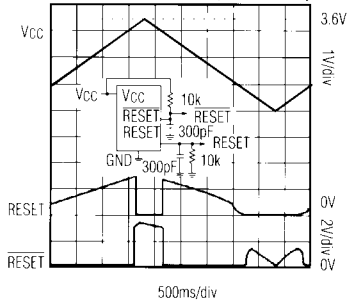

RESET, $\overline{\text{RESET}}$ RESPONSE TIMES

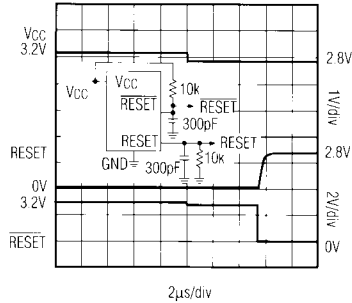

**POWER-FAIL COMPARATOR
ASSERTION RESPONSE TIME**

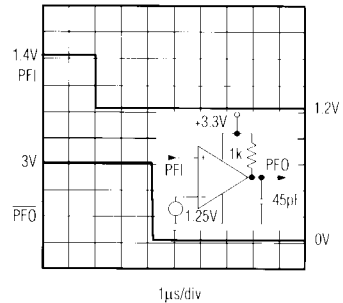

**POWER-FAIL COMPARATOR
DEASSERTION RESPONSE TIME**

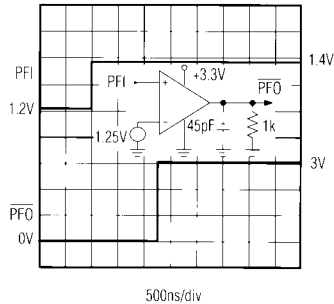

**RESET, $\overline{\text{RESET}}$
RISE AND FALL TIMES
(RESET ASSERTED)**

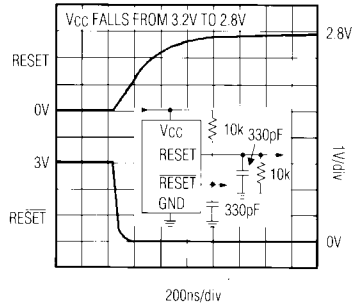

**RESET, $\overline{\text{RESET}}$
RISE AND FALL TIMES
(RESET DEASSERTED)**

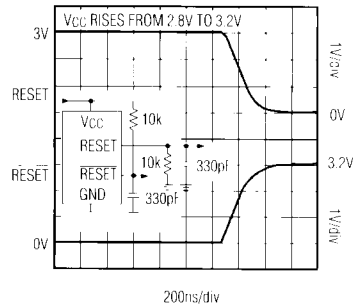

+3V Voltage Monitoring, Low-Cost, μ P Supervisory Circuits

Pin Description

| PIN | | | | | | NAME | FUNCTION |
|---------|-----------|-------------|-----------|-------------|-----------|--------------------|--|
| MAX706P | | MAX706R/S/T | | MAX708R/S/T | | | |
| DIP/SO | μ MAX | DIP/SO | μ MAX | DIP/SO | μ MAX | | |
| 1 | 3 | 1 | 3 | 1 | 3 | \overline{MR} | Manual-Reset Input. When pulled below 0.6V, \overline{MR} triggers a reset pulse. It is TTL/CMOS-compatible when $V_{CC} = 5V$ and can be shorted to ground with a switch. This active-low input has an internal 70 μ A pull-up current. Leave floating or connect to V_{CC} if not used. |
| 2 | 4 | 2 | 4 | 2 | 4 | V_{CC} | Supply-Voltage Input |
| 3 | 5 | 3 | 5 | 3 | 5 | GND | Ground |
| 4 | 6 | 4 | 6 | 4 | 6 | PFI | Power-Fail Comparator Input. When PFI is less than 1.25V, PFO goes low; otherwise PFO remains high. Connect PFI to GND when not used. |
| 5 | 7 | 5 | 7 | 5 | 7 | \overline{PFO} | Power-Fail Output. When PFI is less than 1.25V, \overline{PFO} goes low and sinks current; otherwise, \overline{PFO} remains high. Leave unconnected if not used. |
| 6 | 8 | 6 | 8 | - | - | WDI | Watchdog Input. A rising or falling edge must occur at WDI within 1.6sec or WDO goes low (Figure 4). The internal watchdog timer is reset to zero when reset is asserted or when a transition occurs at WDI. The watchdog function cannot be disabled. |
| - | - | - | - | 6 | 8 | N.C. | No Connect—not internally connected. |
| - | - | 7 | 1 | 7 | 1 | \overline{RESET} | Active-Low Reset Output. \overline{RESET} remains low while V_{CC} is below the reset threshold or \overline{MR} is held low. It remains low for 200ms after the reset condition are terminated (Figure 3). |
| 7 | 1 | - | - | 8 | 2 | RESET | Active-High Reset Output. RESET remains high while V_{CC} is below the reset threshold or \overline{MR} is held low. It remains high for 200ms after the reset conditions are terminated (Figure 3). |
| 8 | 2 | 8 | 2 | - | - | \overline{WDO} | Watchdog Output. \overline{WDO} goes low when a transition does not occur at WDI within 1.6sec, and remains low until a transition occurs at WDI (indicating the watchdog interrupt has been serviced). \overline{WDO} also goes low when V_{CC} falls below the reset threshold; however, unlike the reset output signal, \overline{WDO} goes high as soon as V_{CC} exceeds the reset threshold. |

MAX706P/R/S/T, MAX708R/S/T

Detailed Description

RESET and RESET Outputs

A microprocessor's (μ P's) reset input starts it in a known state. When the μ P is in an unknown state, it should be held in reset. The MAX706P/R/S/T and MAX708R/S/T assert reset when V_{CC} is low, preventing code execution errors during power-up, power-down or brownout conditions.

On power-up, once V_{CC} reaches 1V, \overline{RESET} is guaranteed to be a logic low and RESET is guaranteed to be a logic high. As V_{CC} rises, \overline{RESET} and RESET remain asserted. Once V_{CC} exceeds the reset threshold, the internal timer causes \overline{RESET} and RESET to be deasserted after a time equal to the reset pulse width, which is typically 200ms (Figure 3). If a power-fail or brownout condition occurs (i.e. V_{CC} drops below the reset threshold), \overline{RESET} and RESET are asserted. As long as V_{CC} remains below the reset threshold, the internal timer is continually reset, causing the \overline{RESET} and RESET outputs

to remain asserted. Thus, a brownout condition that interrupts a previously initiated reset pulse causes an additional 200ms delay from the time the latest interruption occurred. On power-down, once V_{CC} drops below the reset threshold, \overline{RESET} and RESET are guaranteed to be asserted for $V_{CC} \geq 1V$.

The MAX706P provides a RESET signal, the MAX706R/S/T provide a \overline{RESET} signal, and the MAX708R/S/T provide both \overline{RESET} and RESET.

Watchdog Timer (MAX706P/R/S/T)

The MAX706P/R/S/T watchdog circuit monitors the μ P's activity. If the μ P does not toggle the Watchdog Input (WDI) within 1.6sec, the Watchdog Output (WDO) goes low (Figure 4). If the reset signal is asserted, the watchdog timer will be reset to zero and disabled. As soon as reset is released, the timer starts counting. WDI can detect pulses as narrow as 100ns with a 2.7V supply and 50ns with a 4.5V supply.

+3V Voltage Monitoring, Low-Cost, μ P Supervisory Circuits

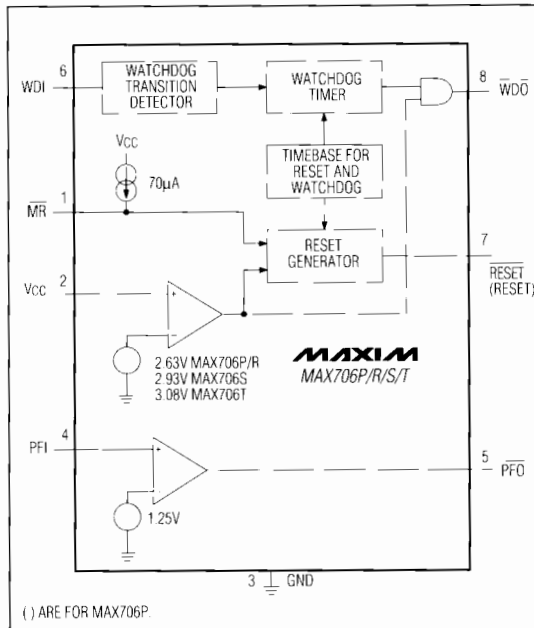

Figure 1. MAX706P/R/S/T Block Diagram

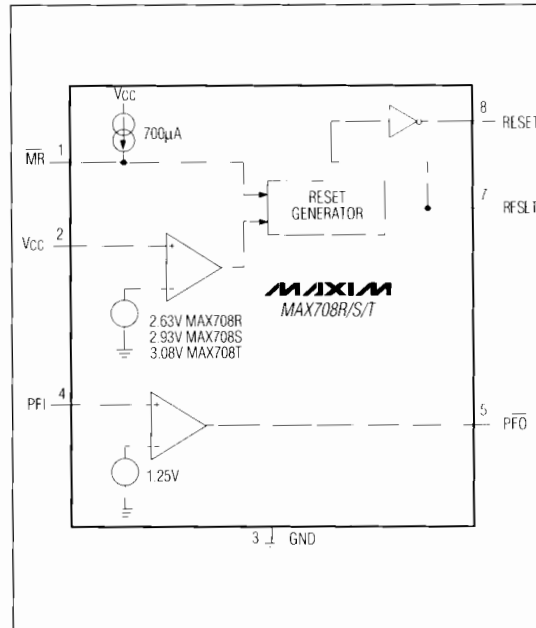

Figure 2. MAX708R/S/T Block Diagram

\overline{WDO} can be connected to the non-maskable interrupt (NMI) input of a μ P. When VCC drops below the reset threshold, \overline{WDO} immediately goes low, even if the watchdog timer has not timed out (Figure 3). Normally, this would trigger an NMI, but since reset is asserted simultaneously, the NMI is overridden. \overline{WDO} can instead be connected to \overline{MR} to generate a reset pulse when the watchdog times out.

Manual Reset

The Manual-Reset (\overline{MR}) input allows \overline{RESET} and RESET to be activated by a pushbutton switch. The switch is effectively debounced by the 140ms minimum reset pulse width. \overline{MR} can be driven by an external logic line since it is TTL/CMOS compatible. The minimum \overline{MR} input pulse width is 500ns when VCC = +3V and 150ns when VCC = +5V. Leave \overline{MR} floating or tie to VCC when not used.

Power-Fail Comparator

The power-fail comparator can be used for various purposes because its output and noninverting input are not internally connected. The inverting input is internally connected to a 1.25V reference. The power-fail com-

parator has 10mV of hysteresis which prevents repeated triggering of the Power-Fail Output (PFO).

To build an early-warning power-failure circuit, use the Power-Fail Comparator Input (PFI) to monitor the unregulated DC supply voltage (see *Typical Operating Circuit*). Connect the PFI pin to a resistor-divider network such that the voltage at PFI falls below 1.25V just before the regulator drops out. Use \overline{PFO} to interrupt the μ P so it can prepare for an orderly power-down.

Regulated and unregulated voltages can be monitored by simply adjusting the PFI resistor-divider network values to the appropriate ratio. In addition, the reset signal can be asserted at voltages other than the VCC reset threshold, as shown in Figure 5. Connect PFO to \overline{MR} to initiate a reset pulse when the 12V supply drops below a user-specified threshold (11V in this example) or when VCC falls below the reset threshold.

Applications Information

Operation with +3V and +5V Supplies

The MAX706P/R/S/T and MAX708R/S/T provide voltage monitoring at the reset threshold (2.63V to 3.08V) when powered from either +3V or +5V. They are ideal in porta-

+3V Voltage Monitoring, Low-Cost, μ P Supervisory Circuits

MAX706P/R/S/T, MAX708R/S/T

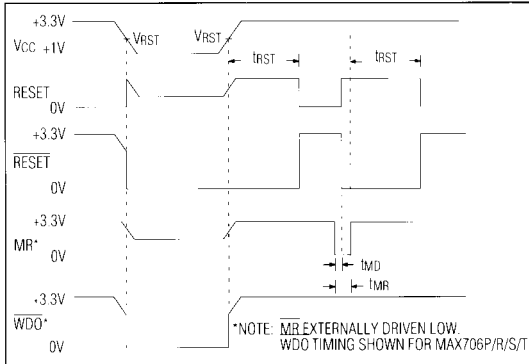

Figure 3. RESET, RESE, MR and WDO Timing

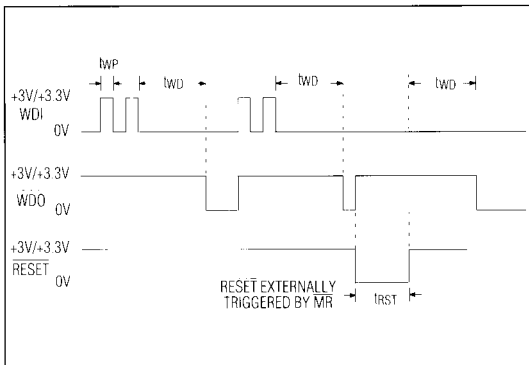

Figure 4. MAX706P/R/S/T Watchdog Timing

ble-instrument applications where power can be supplied from either a +3V battery or an AC-DC wall adapter that generates +5V (a +5V supply allows a μ P or microcontroller to run faster than a +3V supply). With a +3V supply, these ICs consume less power, but output drive capability is reduced, the MR-to-RESET delay time increases, and the MR minimum pulse width increases. The *Electrical Characteristics* table provides specifications for operation with both +3V and +5V supplies.

Ensuring a Valid RESET Output Down to $V_{CC} = 0V$

When V_{CC} falls below 1V, the MAX706R/S/T and MAX708R/S/T RESET output no longer sinks current; it becomes an open circuit. High-impedance, CMOS logic inputs can drift to undetermined voltages if left as open circuits. If a pull-down resistor is added to the RESET pin, as shown in Figure 6, any stray charge or leakage currents will flow to ground, holding RESET low. Resistor

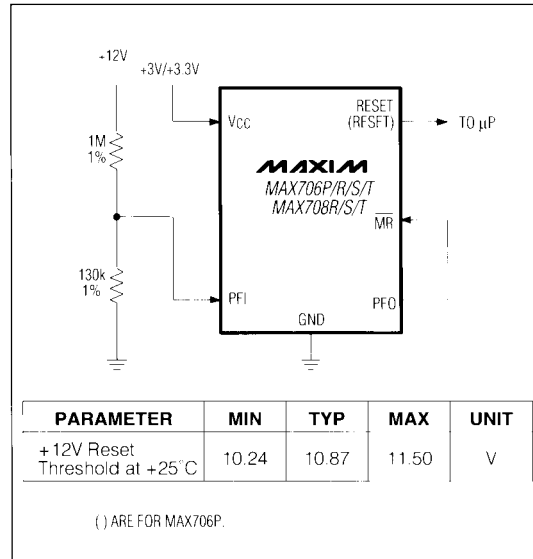

Figure 5. Monitoring Both +3V/+3.3V and +12V

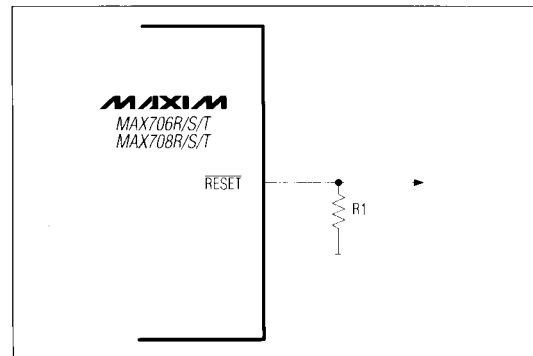

Figure 6. RESET Valid to Ground Circuit

value R_1 is not critical, but it should not load RESET and should be small enough to pull RESET and the input it is driving to ground. 100k Ω is suggested for R_1 .

Adding Hysteresis to the Power-Fail Comparator

Hysteresis adds a noise margin to the power-fail comparator and prevents repeated triggering of PFO when V_{IN} is near the power-fail comparator trip point. Figure 7 shows how to add hysteresis to the power-fail comparator. Select the ratio of R_1 and R_2 such that PFI sees 1.25V when V_{IN} falls to the desired trip point (V_{TRIP}). Resistor R_3 adds hysteresis. R_3 will typically be an order of

+3V Voltage Monitoring, Low-Cost, μ P Supervisory Circuits

magnitude greater than R1 or R2. The current through R1 and R2 should be at least 1 μ A to ensure that the 25nA max PFI input current does not shift the trip point significantly. R3 should be larger than 10k Ω to prevent it from loading down the $\overline{\text{PFO}}$ pin. Capacitor C1 adds noise rejection.

Monitoring a Negative Voltage

The power-fail comparator can be used to monitor a negative supply voltage using the circuit of Figure 8. When the negative supply is valid, $\overline{\text{PFO}}$ is low. When the negative supply voltage drops, $\overline{\text{PFO}}$ goes high. This circuit's accuracy is affected by the PFI threshold tolerance, the VCC voltage, and resistors R1 and R2.

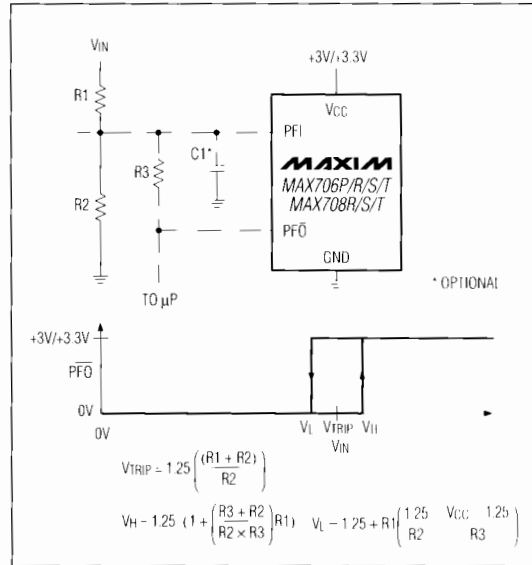

Figure 7. Adding Hysteresis to the Power-Fail Comparator

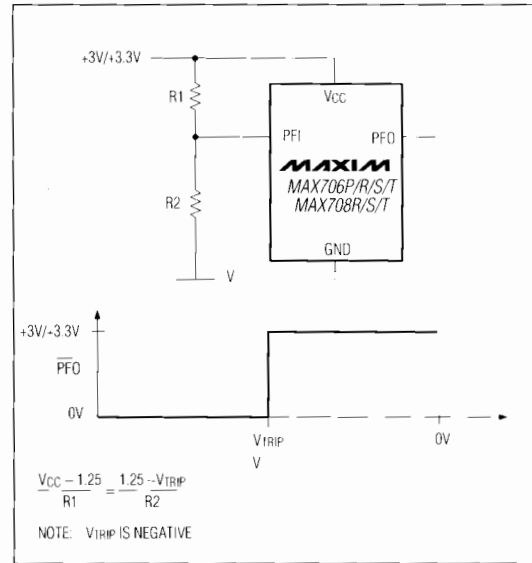
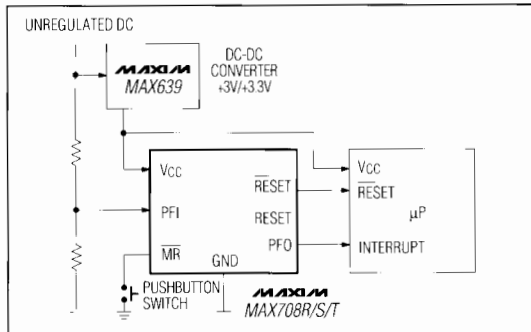

Figure 8. Monitoring a Negative Voltage

+3V Voltage Monitoring, Low-Cost, μ P Supervisory Circuits

Typical Operating Circuits (continued)



Pin Configurations (continued)

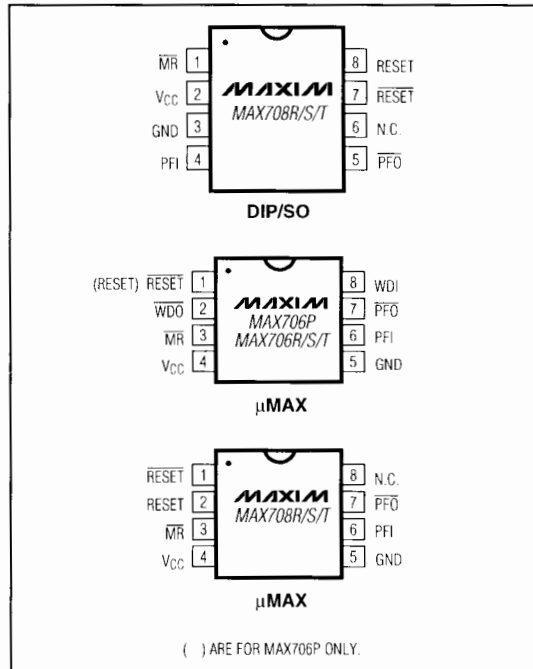

MAX706P/R/S/T, MAX708R/S/T

Chip Information

TRANSISTOR COUNT: 572

+3V Voltage Monitoring, Low-Cost, μ P Supervisory Circuits

MAX706P/R/S/T, MAX708R/S/T

Ordering Information (continued)

| PART | TEMP. RANGE | PIN-PACKAGE |
|-------------------|-----------------|---------------|
| MAX706RCPA | 0°C to +70°C | 8 Plastic DIP |
| MAX706RCSA | 0°C to +70°C | 8 SO |
| MAX706RCUA | 0°C to +70°C | 8 μ MAX |
| MAX706REPA | -40°C to +85°C | 8 Plastic DIP |
| MAX706RESA | -40°C to +85°C | 8 SO |
| MAX706RMJA | -55°C to +125°C | 8 CERDIP* |
| MAX706SCPA | 0°C to +70°C | 8 Plastic DIP |
| MAX706SCSA | 0°C to +70°C | 8 SO |
| MAX706SCUA | 0°C to +70°C | 8 μ MAX |
| MAX706SEPA | -40°C to +85°C | 8 Plastic DIP |
| MAX706SESA | -40°C to +85°C | 8 SO |
| MAX706SMJA | -55°C to +125°C | 8 CERDIP* |
| MAX706TCPA | 0°C to +70°C | 8 Plastic DIP |
| MAX706TCSA | 0°C to +70°C | 8 SO |
| MAX706TCUA | 0°C to +70°C | 8 μ MAX |
| MAX706TEPA | -40°C to +85°C | 8 Plastic DIP |
| MAX706TESA | -40°C to +85°C | 8 SO |
| MAX706TMJA | -55°C to +125°C | 8 CERDIP* |
| MAX708RCPA | 0°C to +70°C | 8 Plastic DIP |
| MAX708RCSA | 0°C to +70°C | 8 SO |
| MAX708RCUA | 0°C to +70°C | 8 μ MAX |
| MAX708REPA | -40°C to +85°C | 8 Plastic DIP |
| MAX708RESA | -40°C to +85°C | 8 SO |
| MAX708RMJA | -55°C to +125°C | 8 CERDIP* |
| MAX708SCPA | 0°C to +70°C | 8 Plastic DIP |
| MAX708SCSA | 0°C to +70°C | 8 SO |
| MAX708SCUA | 0°C to +70°C | 8 μ MAX |
| MAX708SEPA | -40°C to +85°C | 8 Plastic DIP |
| MAX708SESA | -40°C to +85°C | 8 SO |
| MAX708SMJA | -55°C to +125°C | 8 CERDIP* |
| MAX708TCPA | 0°C to +70°C | 8 Plastic DIP |
| MAX708TCSA | 0°C to +70°C | 8 SO |
| MAX708TCUA | 0°C to +70°C | 8 μ MAX |
| MAX708TEPA | -40°C to +85°C | 8 Plastic DIP |
| MAX708TESA | -40°C to +85°C | 8 SO |
| MAX708TMJA | -55°C to +125°C | 8 CERDIP* |

* Contact factory for availability and processing to MIL-STD-883.

+3V Voltage Monitoring, Low-Cost, μ P Supervisory Circuits

Package Information

MAX706P/R/S/T, MAX708R/S/T

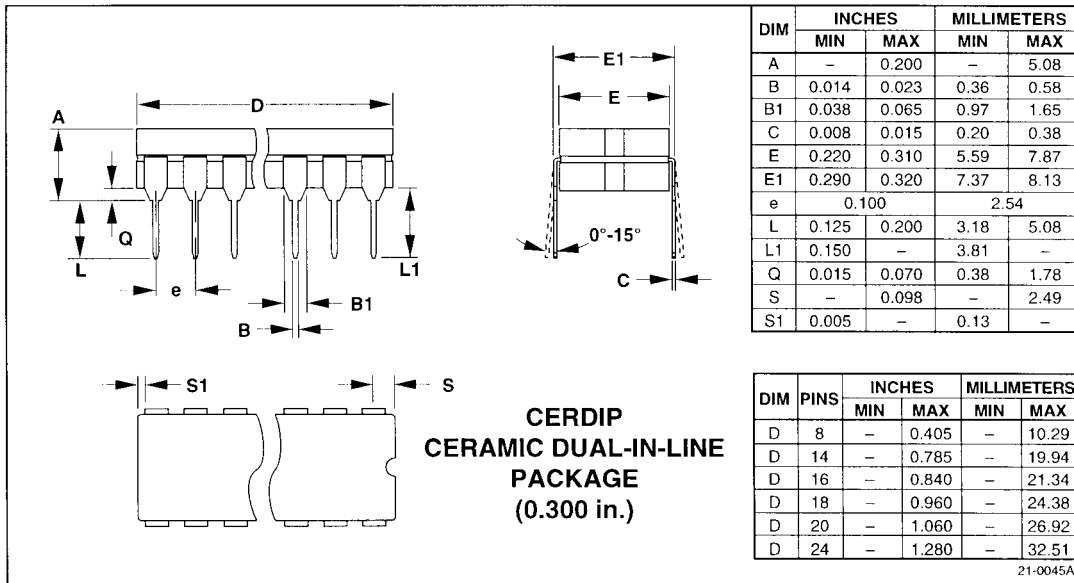
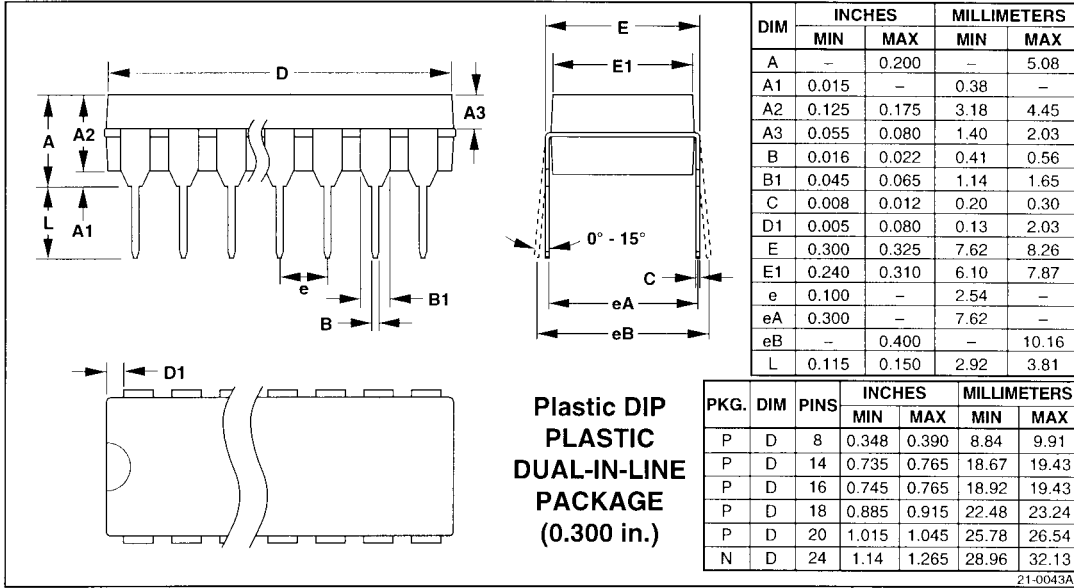

MAX706P/R/S/T, MAX708R/S/T

+3V Voltage Monitoring, Low-Cost, μ P Supervisory Circuits

Package Information (continued)

| DIM | INCHES | | MILLIMETERS | |
|-----|--------|-------|-------------|------|
| | MIN | MAX | MIN | MAX |
| A | 0.053 | 0.069 | 1.35 | 1.75 |
| A1 | 0.004 | 0.010 | 0.10 | 0.25 |
| B | 0.014 | 0.019 | 0.35 | 0.49 |
| C | 0.007 | 0.010 | 0.19 | 0.25 |
| E | 0.150 | 0.157 | 3.80 | 4.00 |
| e | 0.050 | | 1.27 | |
| H | 0.228 | 0.244 | 5.80 | 6.20 |
| L | 0.016 | 0.050 | 0.40 | 1.27 |

**Narrow SO
SMALL-OUTLINE
PACKAGE
(0.150 in.)**

| DIM | PINS | INCHES | | MILLIMETERS | |
|-----|------|--------|-------|-------------|-------|
| | | MIN | MAX | MIN | MAX |
| D | 8 | 0.189 | 0.197 | 4.80 | 5.00 |
| D | 14 | 0.337 | 0.344 | 8.55 | 8.75 |
| D | 16 | 0.386 | 0.394 | 9.80 | 10.00 |

21-0041A

| DIM | INCHES | | MILLIMETERS | |
|-----|--------|-------|-------------|------|
| | MIN | MAX | MIN | MAX |
| A | 0.036 | 0.044 | 0.91 | 1.11 |
| A1 | 0.004 | 0.008 | 0.10 | 0.20 |
| B | 0.010 | 0.014 | 0.25 | 0.36 |
| C | 0.005 | 0.007 | 0.13 | 0.18 |
| D | 0.116 | 0.120 | 2.95 | 3.05 |
| E | 0.116 | 0.120 | 2.95 | 3.05 |
| e | 0.0256 | | 0.65 | |
| H | 0.188 | 0.198 | 4.78 | 5.03 |
| L | 0.016 | 0.026 | 0.41 | 0.66 |
| α | 0° | 6° | 0° | 6° |

**8-PIN μ MAX
MICROMAX SMALL-OUTLINE
PACKAGE**

21-0036D

Maxim cannot assume responsibility for use of any circuitry other than circuitry entirely embodied in a Maxim product. No circuit patent licenses are implied. Maxim reserves the right to change the circuitry and specifications without notice at any time.

12 **Maxim Integrated Products, 120 San Gabriel Drive, Sunnyvale, CA 94086 (408) 737-7600**

© 1995 Maxim Integrated Products

Printed USA

MAXIM is a registered trademark of Maxim Integrated Products.