

MAXIM

+5V Precision Voltage Reference

MAX675

General Description

The MAX675 is a precision voltage reference that is pretrimmed to within $\pm 0.15\%$ of 5V. The reference features excellent temperature stability (as low as 12.0ppm/ $^{\circ}\text{C}$ guaranteed), low current drain and low noise. It is supplied in the space-saving narrow Small Outline package, as well as, the standard 8-pin TO-99 Metal Can, Plastic DIP and CERDIP packages.

Features

- ◆ Pretrimmed to +5V, $\pm 0.15\%$
- ◆ Excellent Temperature Stability: 12ppm/ $^{\circ}\text{C}$
- ◆ Low Noise: $10\mu\text{V}_{\text{p-p}}$
- ◆ Low Supply Current: 1.4mA Max
- ◆ Short-Circuit Proof
- ◆ Load Regulation 0.001%/mA
- ◆ Pin-For-Pin Compatible with REF02

Applications

A/D Converters
D/A Converters
Digital Voltmeters
Voltage Regulators
Threshold Detectors

Ordering Information

PART	PACKAGE*	TEMP. COEFFICIENT ppm/ $^{\circ}\text{C}$	INITIAL ERROR mV
TEMP. RANGE: 0°C to $+70^{\circ}\text{C}$			
MAX675CTV	TO-99	12	7
MAX675CPA	Plastic DIP	12	7
MAX675CSA	Narrow SO	12	7
TEMP. RANGE: -40°C to $+85^{\circ}\text{C}$			
MAX675ETV	TO-99	15	7
MAX675EJA	CERDIP	15	7
MAX675EPA	Plastic DIP	15	7
MAX675ESA	Narrow SO	15	7
TEMP. RANGE: -55°C to $+125^{\circ}\text{C}$			
MAX675MTV	TO-99	20	7
MAX675MJA	CERDIP	20	7

*All devices — 8-pin packages

Pin Configuration

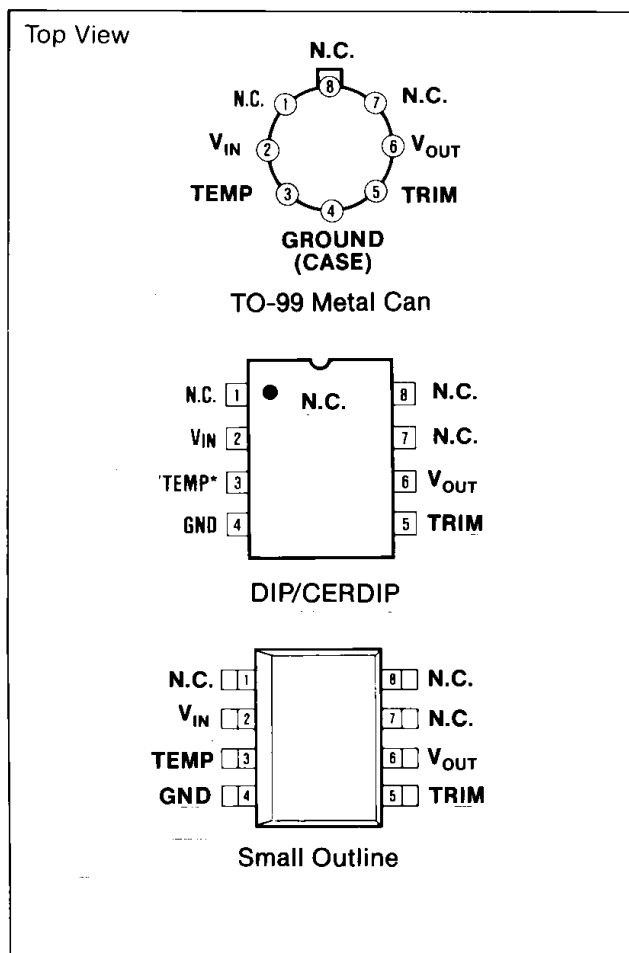

Typical Operating Circuit

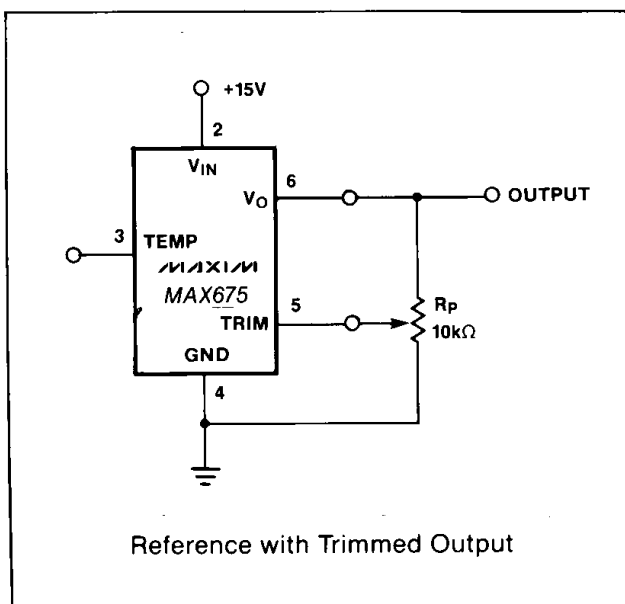

MAXIM

Maxim Integrated Products 1

For free samples & the latest literature: <http://www.maxim-ic.com>, or phone 1-800-998-8800

+5V Precision Voltage Reference

ABSOLUTE MAXIMUM RATINGS

Input Voltage	40V	Operating Temperature Range	
Power Dissipation		MAX675C	0°C to +70°C
TO-99 (TV) (Derate at 7.1mW/°C above +80°C)	500mW	MAX675E	-40°C to +85°C
CERDIP (J) (Derate at 6.7mW/°C above +75°C)	500mW	MAX675M	-55°C to +125°C
Plastic DIP (P) (Derate at 5.6mW/°C above +36°C)	500mW	Lead Temperature (Soldering, 60 sec)	+300°C
Narrow Small Outline (S)		DICE Junction Temperature (T _J)	-65°C to +150°C
(Derate at 5.0mW/°C above +55°C)	300mW	Output Short-Circuit Duration	
Storage Temperature Range	-65°C to +150°C	(to Ground or V _{IN})	Indefinite

Stresses above those listed under "Absolute Maximum Ratings" may cause permanent damage to the device. These are stress ratings only, and functional operation of the device at these or any other conditions above those indicated in the operational sections of the specification is not implied. Exposure to absolute maximum rating conditions for extended periods may affect the device reliability.

ELECTRICAL CHARACTERISTICS (V_{IN} = +15V, T_A = +25°C, unless otherwise noted.)

PARAMETER	SYMBOL	CONDITIONS	MIN	TYP	MAX	UNITS
Output Voltage Tolerance		I _L = 0mA			±7	mV
Output Voltage Change with Temperature	TCV _O	MAX675CTV/CPA/CSA MAX675ETV/EJA/EPA/ESA MAX675MTV/MJA			12 15 20	ppm/°C
Output Adjustment Range	V _{TRIM}	R _p = 10	±150	±300		mV
Line Regulation (Note 1)		V _{IN} = 8V to 33V		0.006	0.01	%/V
Load Regulation (Note 1)		I _L = 0 to 10mA		0.001	0.002	%/mA
Turn-on Settling Time	t _{ON}	To ±0.1% of final value		5		μs
Quiescent Supply Current	I _Q	No Load		750	1400	μA
Noise (Note 3)	e _n p-p	0.1Hz to 10Hz		10	15	μV _{p-p}
Sink Current	I _S		-0.3	-0.5		mA
Short-Circuit	I _{SC}	V _O = 0		30		mA
Current Temperature Voltage Output	V _T	(Note 2)		630		mV

Note 1: Line and Load Regulation specifications include the effect of self heating.

Note 2: Limit current in or out of pin 3 to 50nA and capacitance on pin 3 to 30pF.

Note 3: Noise is sample tested.

+5V Precision Voltage Reference

Output Adjustment

The MAX675 trim terminal can be used to adjust the output voltage over a $5V \pm 150mV$ range. This allows system errors to be trimmed by setting the reference to a voltage other than 5V such as 5.120V for binary applications (see "Typical Operating Circuit" on first page). The trim terminal may, of course, be left open if no adjustment is needed.

Adjustment of the output does not significantly affect the temperature performance of the device. The temperature coefficient change is approximately $0.7ppm/^{\circ}C$ for each 100mV of output adjustment from its initial value.

Temperature Voltage Output

The MAX675 provides a temperature dependent output voltage on the TEMP pin. This voltage is proportional to the absolute temperature, and has a scale factor of approximately $2.1mV/^{\circ}C$ (Figure 2).

Output Voltage = $2.1(T + 273)mV$
where T = Temperature in $^{\circ}C$

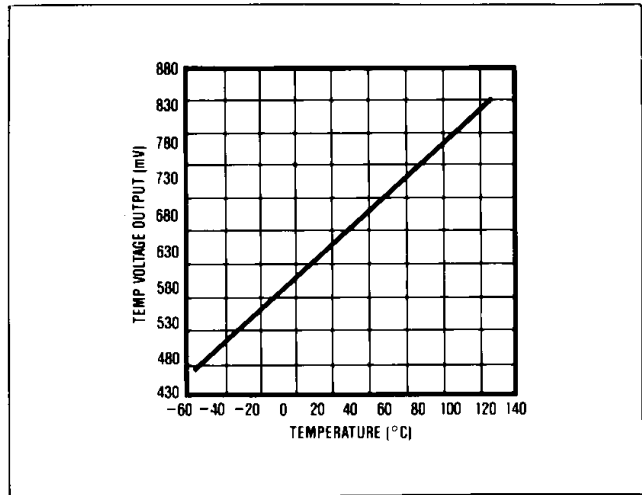
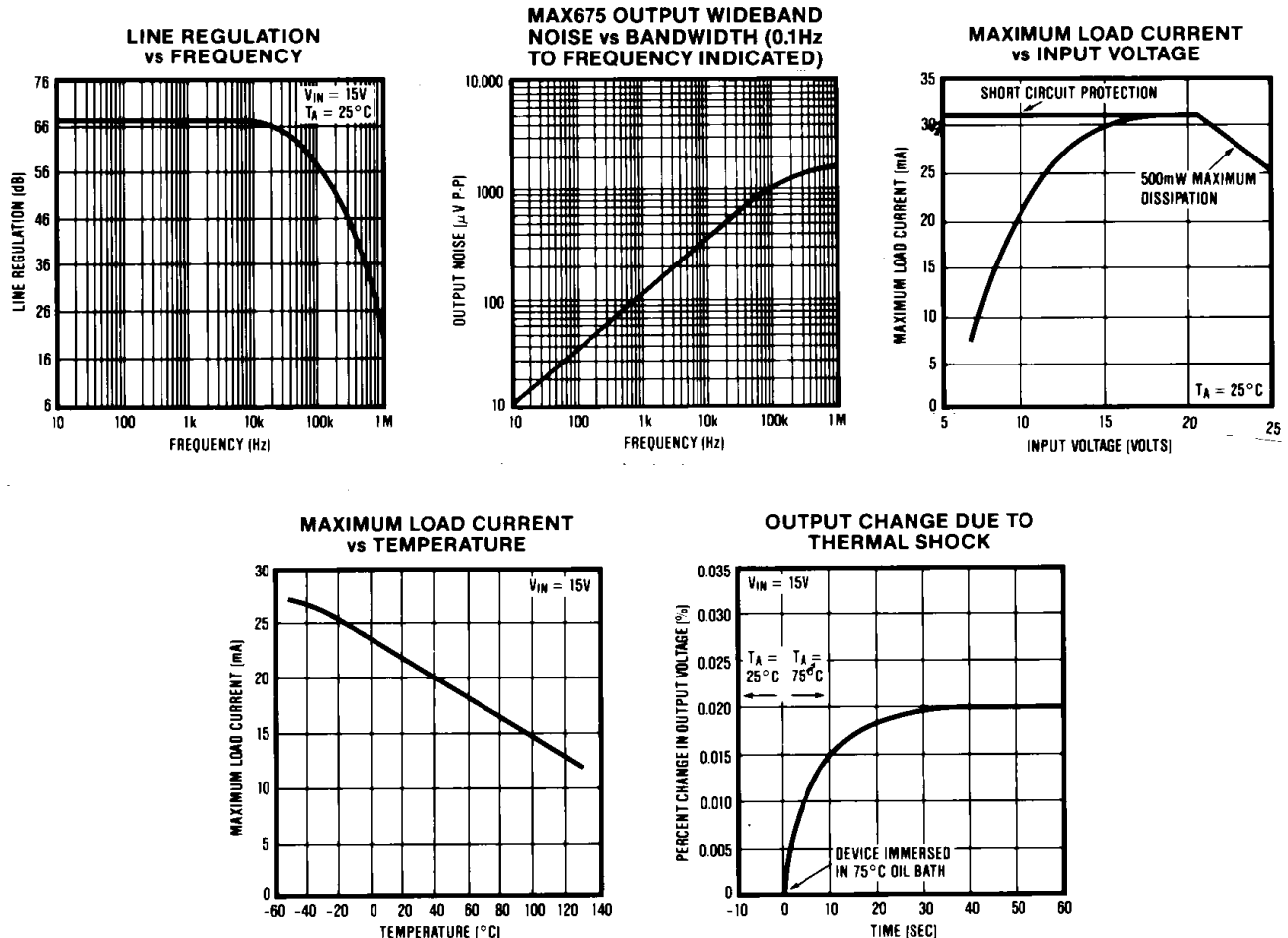

Figure 2. MAX675 Temperature Voltage Output vs. Temperature

Typical Operating Characteristics



+5V Precision Voltage Reference

Typical Applications

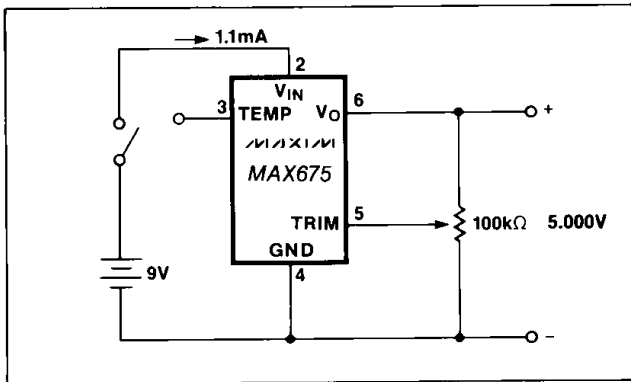

Figure 3. Precision Calibration Standard

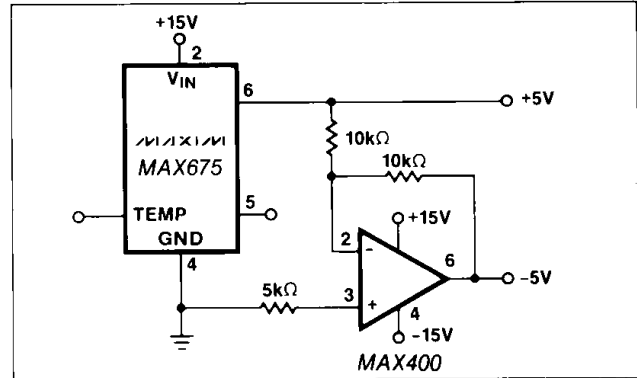

Figure 4. +5V Reference

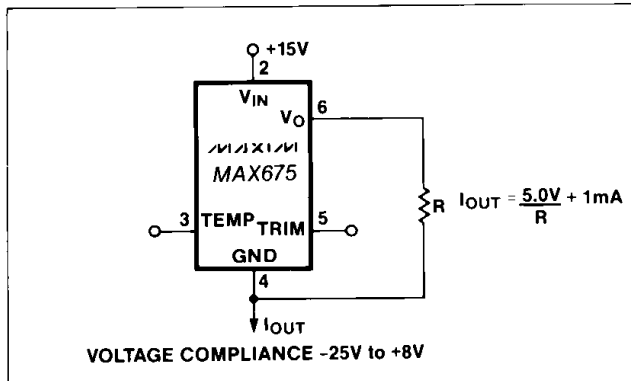

Figure 5. Current Source

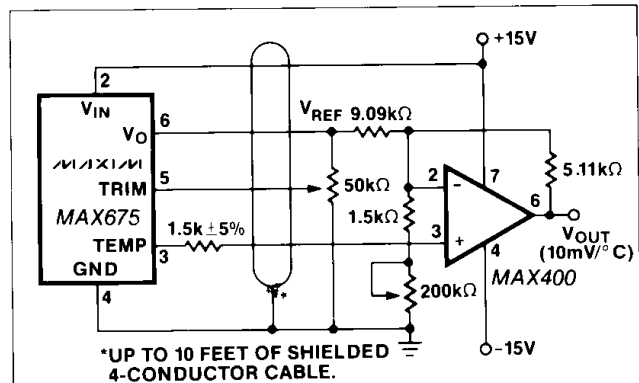
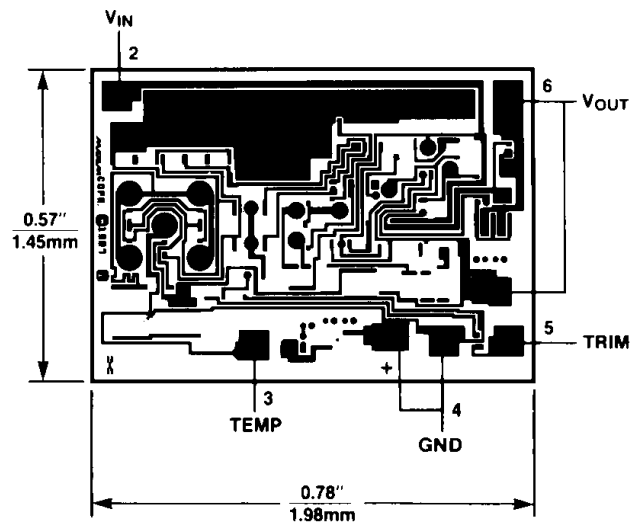

Figure 6. Precision Temperature Transducer with Remote Sensor

Chip Topography



Maxim cannot assume responsibility for use of any circuitry other than circuitry entirely embodied in a Maxim product. No circuit patent licenses are implied. Maxim reserves the right to change the circuitry and specifications without notice at any time.

4 Maxim Integrated Products, 120 San Gabriel Drive, Sunnyvale, CA 94086 (408) 737-7600