

RF POWER MODULES SATELLITE COMMUNICATIONS APPLICATIONS

PRELIMINARY DATA

- SATELLITE COMMUNICATIONS AMPLIFIER
- 1625 - 1665 MHz
- 18/28 VOLTS
- INPUT/OUTPUT 50 OHMS
- $P_{OUT} = 10$ W MIN.
- GAIN = 30 dB MIN.

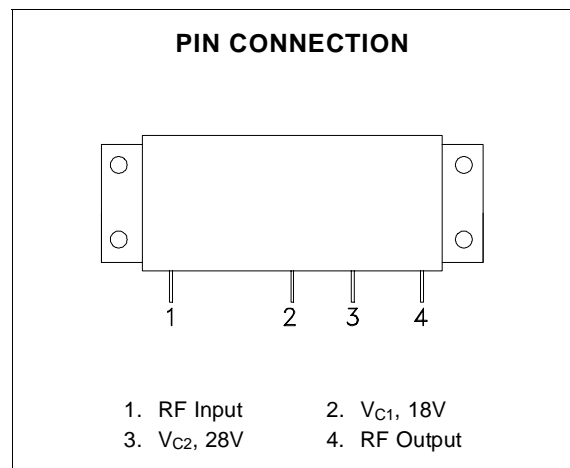
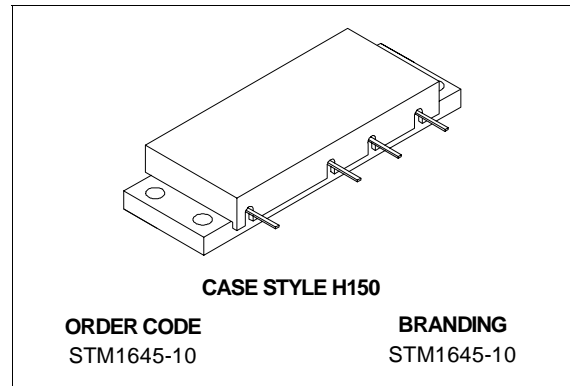

DESCRIPTION

The STM1645-10 module is designed for high power satellite communication applications in the 1.6 GHz frequency range operating at 28 Volts.

ABSOLUTE MAXIMUM RATINGS ($T_{case} = 25^{\circ}C$)

Symbol	Parameter	Value	Unit
V_{C1}	DC Supply Voltage	20	Vdc
V_{C2}	DC Supply Voltage	32	Vdc
P_{IN}	RF Input Power	20	mW
P_{OUT}	RF Output Power	16	W
T_{STG}	Storage Temperature	- 40 to +100	$^{\circ}C$
T_C	Operating Case Temperature	- 35 to +70	$^{\circ}C$

ELECTRICAL SPECIFICATIONS (T_{case} = 25 °C, V_{C1*} = 18 V, V_{C2} = 28 V)

Symbol	Parameter	Test Conditions	Value			Unit
			Min.	Typ.	Max.	
BW	Frequency Range		1625	—	1665	MHz
P _{IN}	Input Power	P _{OUT} = 10 W	—	—	10.0	dBm
G _P	Power Gain	P _{OUT} = 10 W	30	—	—	dB
η	Efficiency	P _{OUT} = 10 W	30	35	—	%
H	Harmonics	P _{OUT} = 10 W reference	—	-45	-40	dBc
Z _{IN}	Input Impedance	P _{OUT} = 10 W Z _G , Z _L = 50Ω	—	1.5:1	2.0:1	VSWR
—	Load Mismatch	VSWR = 10:1 V = 28 Vdc P _{OUT} = 10 W	No Degradation in Output Power			

*Note: V_{C1} = 18V Regulated ± 1%

D.C. TEST FIXTURE BYPASSING

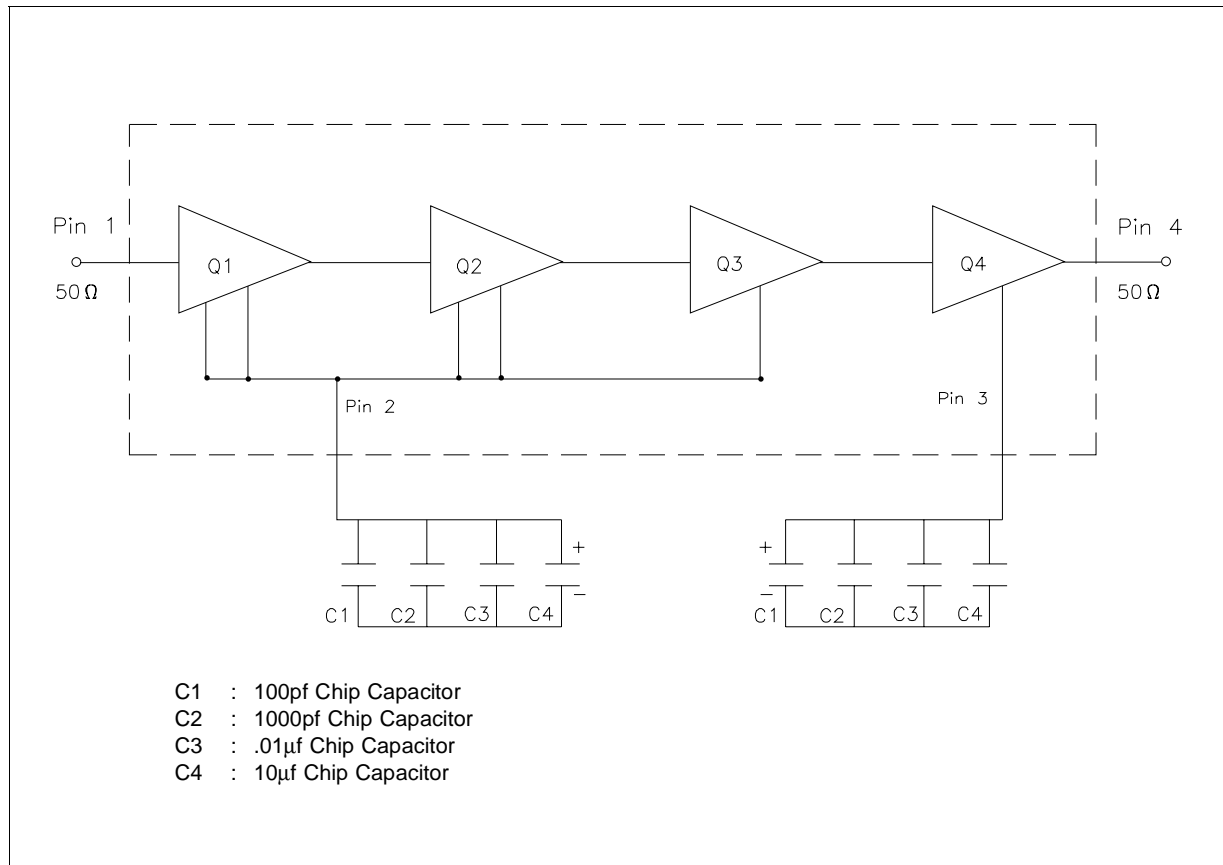

TYPICAL PERFORMANCE

POWER OUTPUT vs FREQUENCY

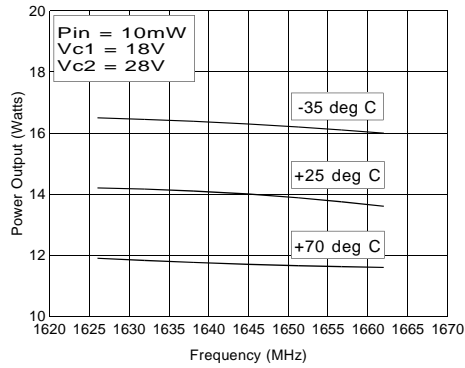

VC2 vs FLANGE TEMPERATURE

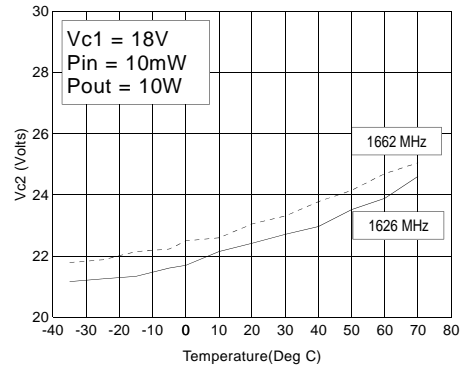

APPLICATIONS RECOMMENDATIONS**OPERATION LIMITS**

The STM1645-10 power module should never be operated under any condition which exceeds the Absolute Maximum Ratings presented on this data sheet. Nor should the module be operated continuously at any of the specified maximum ratings. If the module is to be subjected to one or more of the maximum rating conditions, care must be taken to monitor other parameters which may be affected.

DECOUPLING

Failure to properly decouple any of the voltage supply pins may result in oscillations at certain operating frequencies. Therefore, it is recommended that these pins be bypassed as indicated in the Module DC and Test Fixture Configuration drawing of this data sheet.

POWER CONTROL

The recommended method of power control for the STM1645-10 is to set $P_{IN} = 10\text{mW}$, $V_{C1} = 18\text{V}$ and $V_{C2} = 28$ volts nominal at a flange temperature of 25°C to achieve an output power of 10 watts. Varying V_{C2} will allow stable power control over a wide range of flange temperature. The current consumption of V_{C2} is typically 850mA to 900mA for 10 watts power output.

MODULE MOUNTING

To insure adequate thermal transfer from the module to the heatsink, it is recommended that a satisfactory thermal compound such as Dow Corning 340, Wakefield 120-2 or equivalent be applied between the module flange and the heatsink.

The heatsink mounting surface under the module should be flat to within $\pm 0.05\text{mm}$ (± 0.002 inch). The module should be mounted to the heatsink using 3 mm (or 4-40) or equivalent screws torqued to 5-6 kg-cm (4-6 in-lb).

The module leads should be attached to equipment PC board using 180°C solder applied to the leads with a properly grounded soldering iron tip, not to exceed 195°C , applied a minimum of 2mm (0.080 inch) from the body of the module for a duration not to exceed 15 seconds per lead. It is imperative that no other portion of the module, other than the leads, be subjected to temperatures in excess of 100°C (maximum storage temperature), for any period of time, as the plastic moulded cover, internal components and sealing adhesives may be adversely affected by such conditions.

Due to the construction techniques and materials used within the module, reflow soldering of the flange heatsink or leads, is not recommended.

PACKAGE MECHANICAL DATA

Ref.: Dwg. No. 1018019 rev. D

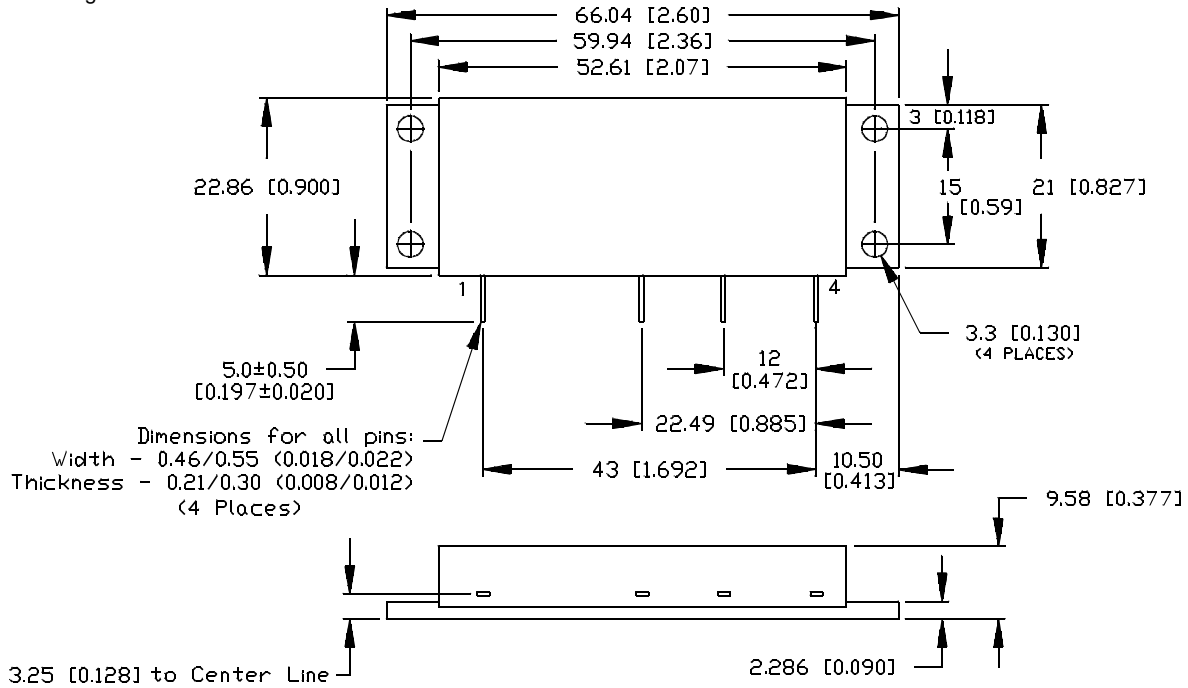

NOTES:

All tolerances $\pm 0.25\text{mm}$ [$\pm 0.010\text{in}$] unless otherwise specified.
 Numbers in [] are inches.

Information furnished is believed to be accurate and reliable. However, SGS-THOMSON Microelectronics assumes no responsibility for the consequences of use of such information nor for any infringement of patents or other rights of third parties which may result from its use. No license is granted by implication or otherwise under any patent or patent rights of SGS-THOMSON Microelectronics. Specifications mentioned in this publication are subject to change without notice. This publication supersedes and replaces all information previously supplied. SGS-THOMSON Microelectronics products are not authorized for use as critical components in life support devices or systems without express written approval of SGS-THOMSON Microelectronics.

©1996 SGS-THOMSON Microelectronics - All Rights Reserved

SGS-THOMSON Microelectronics GROUP OF COMPANIES

Australia - Brazil - France - Germany - Hong Kong - Italy - Japan - Korea - Malaysia -
 Malta - Morocco - The Netherlands - Singapore - Spain - Sweden - Switzerland - Taiwan -
 Thailand - United Kingdom - U.S.A.