

**DATA DISPLAY AG**

**LM157E2-A2**  
**15,7" SXGA TFT LCD**

**PRELIMINARY**  
**SPECIFICATION**

The information given in this document is carefully checked and believed to be reliable. Data Display reserves the right to make changes in product or specification at any time and without further notice. Data Display products are not intended for use in systems in which failures of product could result in personal injury. All mentioned trademarks are registered trademarks of their owner.

LG.Philips LCD: Rev. 0.1, Sep 30, 2000



## 1. GENERAL DESCRIPTION

The LM157E2-A2 is a Color Active Matrix Liquid Crystal Display with an integral Cold Cathode Fluorescent Lamp (CCFL) back light system. The matrix employs a-Si Thin Film Transistor as the active element. It is a transmissive type display operating in the normally white mode. This TFT-LCD has a 15.7 inch diagonally measured active display area with SXGA resolution (1024 vertical by 1280 horizontal pixel array). Each pixel is divided into Red, Green and Blue sub-pixels or dots which are arranged in vertical stripes. Gray scale or the brightness of the sub-pixel color is determined with a 8-bit gray scale signal for each dot, thus, presenting a palette of more than 16,777,216 colors.

The LM157E2-A2 has been designed to apply the interface method that enables low power, high speed low EMI. FPD Link must be used as a LVDS (Low Voltage Differential Signaling) chip.

The LM157E2-A2 is intended to support applications where thin thickness and low power consumption are critical factors and graphic displays are important. In combination with the vertical arrangement of the sub-pixels, the LM157E2-A2 characteristics provide an excellent flat panel display e.g. automation products, industrial monitors or point of information terminals.

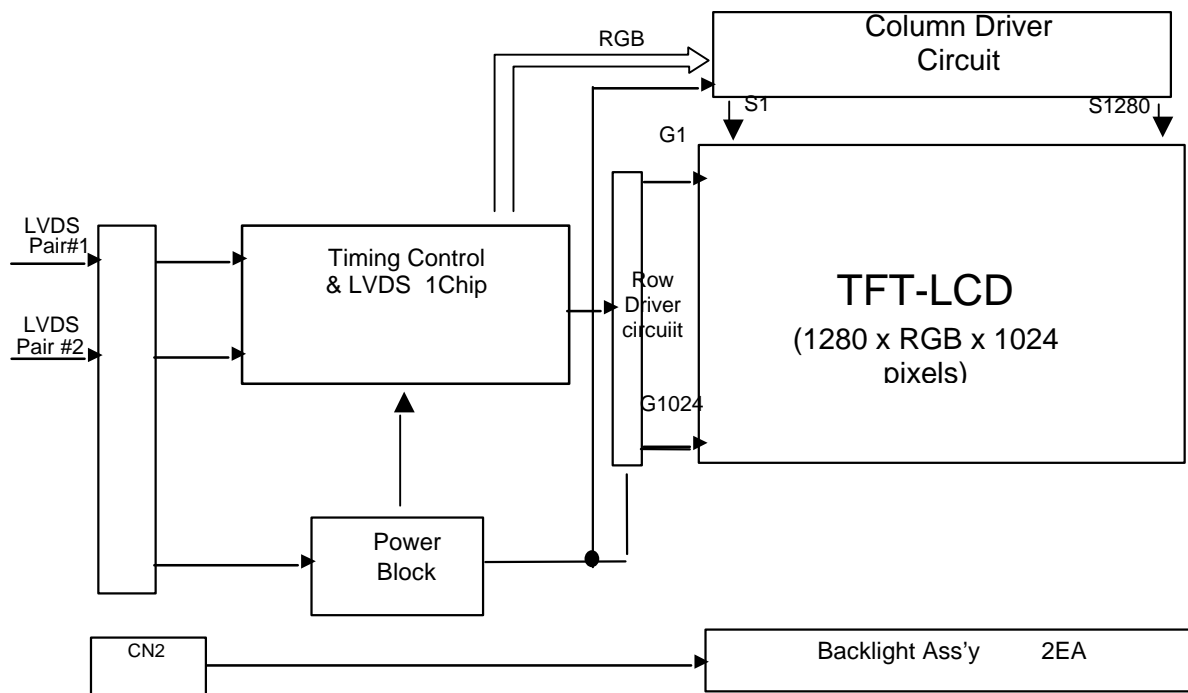

**1.1 General Features**

The following are general feature of the model LM157E1-A2 LCD:

Active screen size	15.7 inches (39.832 cm) diagonal
Outline dimensions	335.0 (H) × 273.5 (V) × 11.2 (D) mm (Typ.)
Pixel pitch	0.243 mm × 0.243 mm
Pixel format	1280 horiz. By 1024 vert. pixels
	RGB stripe arrangement
Color depth	8-bit, 16,777,216 colors
Luminance,White	200 cd/m <sup>2</sup> (5 point Average.)
Power Consumption	Total 12.57 Watt, typ (2.97 Watt @IV <sub>AA</sub> , 9.6 Watt @ 200 cd/m <sup>2</sup> [Lamp])
Weight	1140 (typ)
Display operating mode	Transmissive mode, normally white
Surface treatments	Hard coating(3H), anti-glare treatment of the front polarizer



## 2. MAXIMUM RATINGS

The following are maximum values which, if exceeded, may cause faulty operation or damage to the unit.

Table 1. ABSOLUTE MAXIMUM RATINGS

Parameter	Symbol	Values		Units	Notes
		Min.	Max.		
Power Input Voltage	$V_{CC}$	-0.3	+3.5	Vdc	at 25 °C
Operating Temperature	$T_{OP}$	0	+50	°C	1,2
Storage Temperature	$T_{ST}$	-20	+60	°C	1,2

Note 1: Temperature at 5mm above display center of LCD Module.

$T_a = 40\text{ °C}$ : 90%RH Max

$T_a \text{ °C } 40\text{ °C}$ : Absolute Humidity shall be less than  $T_a = 40\text{ °C } 90\%$  RH .  
These shall be no dew condensation.

Note 2: Humidity Min. 5%RH, Max. 95%RH

Note 3: Temperature and relative humidity range are shown in the figure below.  
Wet bulb temperature should be 39 °C max, and no condensation of water.

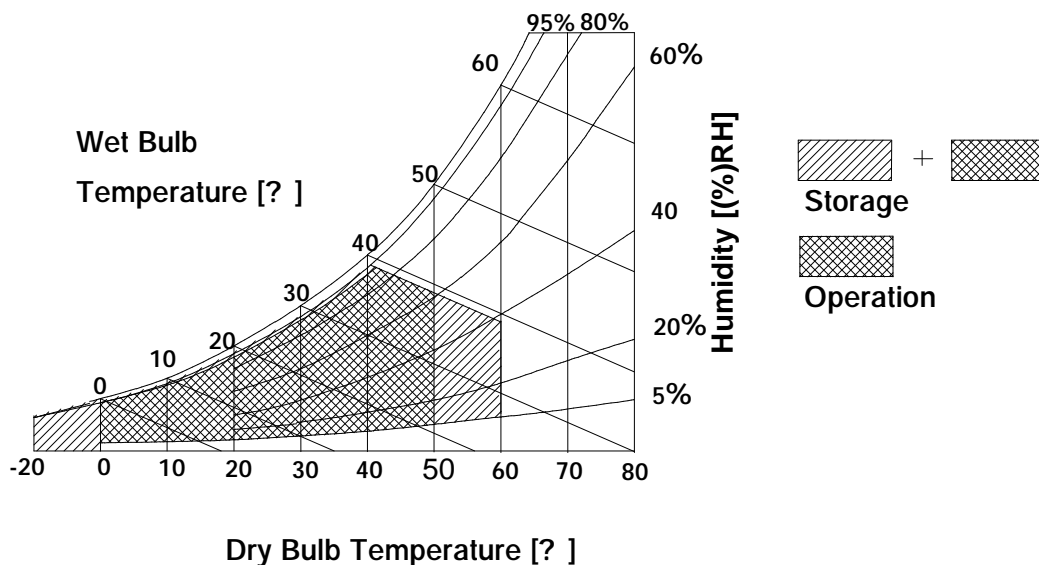

### 3. ELECTRICAL SPECIFICATIONS

#### 3.1 Electrical Characteristics

The LM157E2-A2 requires two power inputs. One is employed to power the LCD electronics and to drive the TFT array and liquid crystal. The other input which powers the CCFL, is typically generated by an inverter. The inverter is an external unit to the LCD.

Table 2. ELECTRICAL CHARACTERISTICS

Parameter	Symbol	Values			Units	Notes
		Min.	Typ.	Max.		
<b>MODULE:</b>						
Power Supply Input Voltage	V <sub>CC</sub>	3.1	3.3	3.5	V <sub>dc</sub>	
Power Supply Input Current	I <sub>CC</sub>	-	900	1400	mA	1
Differential Impedance	Z <sub>m</sub>	90	100	110	Ohm	
Power Consumption	P <sub>C</sub>	-	2.97	4.62	Watt	1
<b>LAMP</b>						
Operating Voltage	V <sub>BL</sub>	590(8.5mA)	600(8mA)	730(3mA)	V <sub>RMS</sub>	2
Operating Current	I <sub>BL</sub>	(3.0)	(8.0)	(8.5)	mA	
Established Starting Voltage at 25 °C				(865)	V <sub>RMS</sub>	3
at 0 °C				(1210)	V <sub>RMS</sub>	
Operating Frequency	f <sub>BL</sub>	-	58	80	KHz	4
Discharge Stabilization Time	T <sub>S</sub>	40	-	3	Minutes	6
Power Consumption(2CCFL's)	P <sub>BL</sub>	-	9.6	10.0	Watts	5
Halflife Time		30,000		-	Hrs	7

Note: **The design of the inverter must have specifications for the lamp in LCD Assembly.**

The performance of the Lamp in LCM, for example life time or brightness, is extremely influenced by the characteristics of the DC-AC Inverter. So all the parameters of an inverter should be carefully designed so as not to produce too much leakage current from high-voltage output of the inverter.

When you design or order the inverter, please make sure unwanted lighting caused by the mismatch of the lamp and the inverter (no lighting, flicker, etc) never occurs. When you confirm it, the LCD Assembly should be operated in the same condition as installed in your instrument.

Note 1: The current draw and power consumption specified is for 3.3 V<sub>dc</sub> at 25 °C and f<sub>v</sub> at 60Hz. (at chess 8X6 pattern)

Note 2: The variance of the voltage is ±10%.

Note 3: The output voltage at the transformer in the inverter must be high considering to the loss of the ballast capacitor in the inverter.

Note 4: The output of the inverter must have symmetrical (negative and positive) voltage waveform and symmetrical current waveform. (Unsymmetrical ratio is less than 10%) Please do not use the inverter which has unsymmetrical voltage and unsymmetrical current and spike wave.



Lamp frequency may produce interference with horizontal synchronous frequency and as a result this may cause beat on the display. Therefore lamp frequency shall be as away as possible from the horizontal synchronous frequency and from its harmonics in order to prevent interference.

Note 5: The lamp power consumption shown above does not include loss of external inverter.

Note 6: Let's define the brightness of the lamp after being lighted for 5 minutes as 100%.

$T_s$  is the time required for the brightness of the center of the lamp to be not less than 95%.

Note 7: The life time is determined as the time at which brightness of lamp is 50% compare to that of initial value at the typical lamp current on condition of continuous operating at  $25 \pm 2$  °C.

### 3.2 Interface Connections

Interface chip must be used LVDS, part No. DS90CF383MTD (Transmitter), DS90CF384MTD (Receiver) made by National Semiconductor. Or used the compatible interface chips (TI : SN75LVDS83, Thine).

This LCD employs three interface connections. A 30-pin connector is used for the module electronics interface and power interface.

The electronics interface connector is a model DF19K-30P-H manufactured by HIROSE. The pin configuration for the connector is shown in the table 3.



Table 3: MODULE CONNECTOR PIN CONFIGURATION (LVDS)

Pin	Symbol	Description	Notes
1	3.3V	3.3V	
2	3.3V	3.3V	
3	3.3V	3.3V	
4	3.3V	3.3V	
5	GND	GROUND	
6	GND	GROUND	
7	E_RX0-	Minus Signal of Even Channel 0 (LVDS)	} <b>Second Data</b>
8	E_RX0+	Plus Signal of Even Channel 0 (LVDS)	
9	E_Rx1-	Minus Signal of Even Channel 1 (LVDS)	
10	E_RX1+	Plus Signal of Even Channel 1 (LVDS)	
11	E_RX2-	Minus Signal of Even Channel 2 (LVDS)	
12	E_RX2+	Plus Signal of Even Channel 2 (LVDS)	
13	E_RXC-	Minus Signal of Even Clock Channel(LVDS)	
14	E_RXC+	Plus Signal of Even Clock Channel(LVDS)	
15	E_RX3-	Minus Signal of Even Channel 3 (LVDS)	
16	E_RX3+	Plus Signal of Even Channel 3 (LVDS)	
17	GND	GROUND	
18	GND	GROUND	
19	O_RX0-	Minus Signal of Odd Channel 0 (LVDS)	} <b>First Data</b>
20	O_RX0+	Plus Signal of Odd Channel 0 (LVDS)	
21	O_RX1-	Minus Signal of Odd Channel 1 (LVDS)	
22	O_RX1+	Plus Signal of Odd Channel 1 (LVDS)	
23	O_RX2-	Minus Signal of Odd Channel 2 (LVDS)	
24	O_RX2+	Plus Signal of Odd Channel 2 (LVDS)	
25	O_RXC-	Minus Signal of Odd Clock Channel(LVDS)	
26	O_RXC+	Plus Signal of Odd Clock Channel(LVDS)	
27	O_RX3-	Minus Signal of Odd Channel3(LVDS)	
28	O_RX3+	Plus Signal of Odd Channel3(LVDS)	
29	GND	GROUND	
30	GND	GROUND	

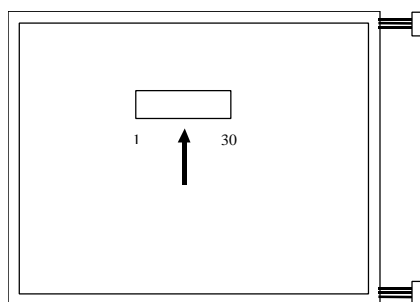

Transparent View

The backlight interface connector is a model BHR-03VS-1, manufactured by JST. The mating connector part number is SM02(8.0)B-BHS-1-TB or equivalent. The pin configuration for the connector is shown in the table below.



**Table 4: BACKLIGHT CONNECTOR PIN CONFIGURATION**

Pin	Symbol	Description	Notes
1	HV	Lamp power input	1
2	Open	Open	
3	LV	GROUND	2

Note 1: The input power terminal is colored pink . Ground pin color is white.

Note 2: **The lamp ground should be common with GND.**

**Table 5: Required Signal Assignment for FlatLink**

Pin #	Pin Name	Required Signals	Pin #	Pin Name	Required Signals
1	Vcc	Power supply for TTL input	29	GND	Ground pin for TTL
2	D5	TTL Input(R7)	30	D26	TTL Input (Data Enable)
3	D6	TTL Input (R5)	31	TxCLKIN	TTL Input clock input
4	D7	TTL Input (G0)	32	PWR DWN	Power down input
5	GND	Ground pin for TTL	33	PLL GND	Ground pin for PLL
6	D8	TTL Input (G1)	34	PLL VCC	Power supply for PLL
7	D9	TTL Input (G2)	35	PLL GND	Ground pin for PLL
8	D10	TTL Input (G6)	36	LVDS GND	Ground pin for LVDS
9	Vcc	Power supply for TTL input	37	TxOUT3+	Positive LVDS differential data output 3
10	D11	TTL Input (G7)	38	TxOUT3-	Negative LVDS differential data output 3
11	D12	TTL Input (G3)	39	TxCLKOUT+	Positive LVDS differential clock output
12	D13	TTL Input (G4)	40	TxCLKOUT-	Negative LVDS differential clock output
13	GND	Ground pin for TTL	41	TxOUT2+	Positive LVDS differential data output 2
14	D14	TTL Input (G5)	42	TxOUT2-	Negative LVDS differential data output 2
15	D15	TTL Input (B0)	43	LVDS GND	Ground pin for LVDS
16	D16	TTL Input (B6)	44	LVDS Vcc	Power supply for LVDS
17	Vcc	Power supply for TTL input	45	TxOUT1+	Positive LVDS differential data output 1
18	D17	TTL Input (B7)	46	TxOUT1-	Negative LVDS differential data output 1
19	D18	TTL Input (B1)	47	TxOUT0+	Positive LVDS differential data output 0
20	D19	TTL Input (B2)	48	TxOUT0-	Negative LVDS differential data output 0
21	GND	Ground pin for TTL	49	LVDS GND	Ground pin for LVDS
22	D20	TTL Input (B3)	50	D27	TTL Input (R6)
23	D21	TTL Input (B4)	51	D0	TTL Input (R0)
24	D22	TTL Input (B5)	52	D1	TTL Input (R1)
25	D23	TTL Input (RSVD)	53	GND	Ground pin for TTL
26	Vcc	Power supply for TTL input	54	D2	TTL Input (R2)
27	D24	TTL Input (Hsync)	55	D3	TTL Input (R3)
28	D25	TTL Input (Vsync)	56	D4	TTL Input (R4)

Note 1: Refer to LVDS Transmitter Data Sheet for detail descriptions.





### 3.3 Signal Timing Specification

This is the signal timing required at the input of the LVDS Transmitter. All of the interface signal timing should be satisfied with the following specifications for its proper operation.

Table 6: Timing Table

ITEM	SYMBOL	MIN.	TYP.	MAX.	UNIT	NOTE	
Dclk	Period	$t_{CLK}$	20.00	18.52	18.18	ns	1
Hsync	Period	$t_{HP}$	730	844	-	$t_{CLK}$	
	Width	$t_{WH}$	8	56	-		
Vsync	Period	$t_{VP}$	-	16.67	-	ms	
	Period	$t_{VP}$	1032	1066	-	$t_{HP}$	
	Width	$t_{WV}$	2	3	-		
DE (Data Enable)	Horizontal Back Porch	$t_{HBP}$	12	124	-	$t_{CLK}$	
	Horizontal Active	-	-	640	-		
	Horizontal Front Porch	$t_{HFP}$	6	24	-		
	Vertical Back Porch	$t_{VBP}$	1	38	-		
	Vertical Active	-	-	1024	-	$t_{HP}$	
	Vertical Front Porch	$t_{VFP}$	1	1	-		

Note 1: Two pixel data are sampled at the same time.

Pixel 0,0	Pixel 1,0	pixel 2,0	pixel 3,0			pixel 1278,0	pixel 1279,0
Pixel 0,1	Pixel 1,1	pixel 2,1	pixel 3,1			pixel 1278,1	pixel 1279,1
Pixel 0,1023	Pixel 1,1023	pixel 2,1023	pixel 3,1023			pixel 1278,1023	pixel 1279,1023



**3.4 Signal Timing Wave Form**

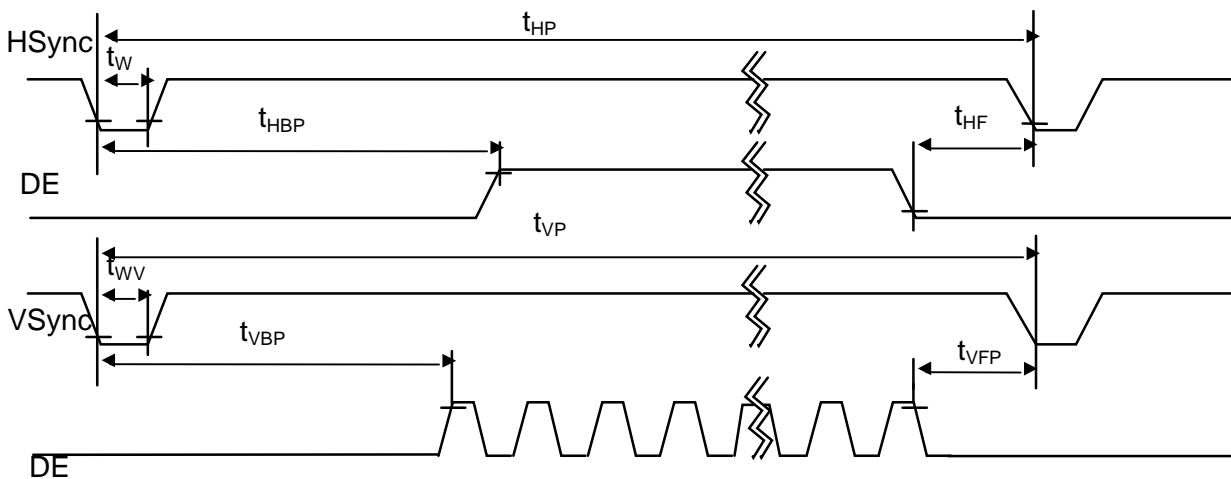
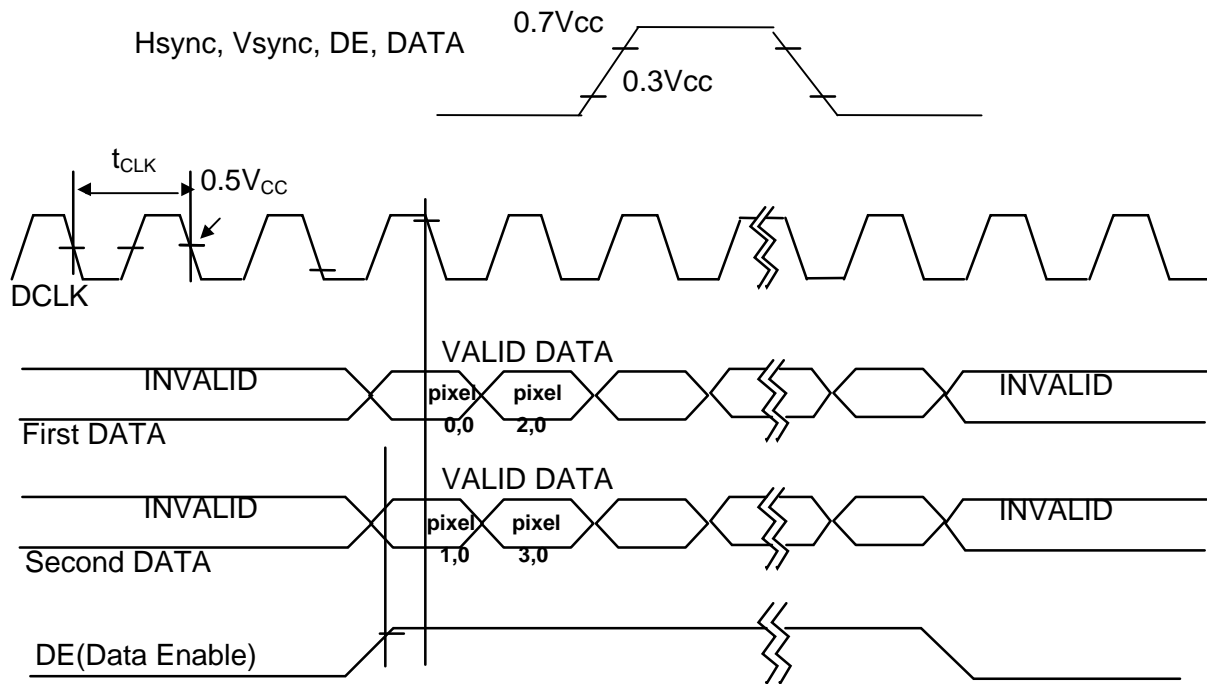

### 3.5 Color Input Data Reference

The brightness of each primary color (red, green and blue) is based on the 8-bit gray scale data input for the color; the higher the binary input, the brighter the color. The table below provides a reference for color versus data input.

Table 7. COLOR DATA REFERENCE

Color		Input Color Data																							
		Red								Green								Blue							
		MSB				LSB				MSB				LSB				MSB				LSB			
		R7	R6	R5	R4	R3	R2	R1	R0	G7	G6	G5	G4	G3	G2	G1	G0	B7	B6	B5	B4	B3	B2	B1	B0
Basic Colors	Black	0	0	0	0	0	0	0	0	0	0	0	0	0	0	0	0	0	0	0	0	0	0	0	0
	Red(255)	1	1	1	1	1	1	1	1	0	0	0	0	0	0	0	0	0	0	0	0	0	0	0	0
	Green(255)	0	0	0	0	0	0	0	0	1	1	1	1	1	1	1	1	0	0	0	0	0	0	0	0
	Blue(255)	0	0	0	0	0	0	0	0	0	0	0	0	0	0	0	0	1	1	1	1	1	1	1	1
	Cyan	0	0	0	0	0	0	0	0	1	1	1	1	1	1	1	1	1	1	1	1	1	1	1	1
	Magenta	1	1	1	1	1	1	1	1	0	0	0	0	0	0	0	0	1	1	1	1	1	1	1	1
	Yellow	1	1	1	1	1	1	1	1	1	1	1	1	1	1	1	1	0	0	0	0	0	0	0	0
	White	1	1	1	1	1	1	1	1	1	1	1	1	1	1	1	1	1	1	1	1	1	1	1	1
Red	Red(000) Dark	0	0	0	0	0	0	0	0	0	0	0	0	0	0	0	0	0	0	0	0	0	0	0	0
	Red(001)	0	0	0	0	0	0	0	1	0	0	0	0	0	0	0	0	0	0	0	0	0	0	0	0
	Red(002)	0	0	0	0	0	0	1	0	0	0	0	0	0	0	0	0	0	0	0	0	0	0	0	0
	:	:	:	:	:	:	:	:	:	:	:	:	:	:	:	:	:	:	:	:	:	:	:	:	
	Red(253)	1	1	1	1	1	1	0	1	0	0	0	0	0	0	0	0	0	0	0	0	0	0	0	0
	Red(254)	1	1	1	1	1	1	1	0	0	0	0	0	0	0	0	0	0	0	0	0	0	0	0	0
	Red(255) Bright	1	1	1	1	1	1	1	1	0	0	0	0	0	0	0	0	0	0	0	0	0	0	0	0
Green	Green(000)Dark	0	0	0	0	0	0	0	0	0	0	0	0	0	0	0	0	0	0	0	0	0	0	0	0
	Green(001)	0	0	0	0	0	0	0	0	0	0	0	0	0	0	1	0	0	0	0	0	0	0	0	0
	Green(002)	0	0	0	0	0	0	0	0	0	0	0	0	0	1	0	0	0	0	0	0	0	0	0	0
	:	:	:	:	:	:	:	:	:	:	:	:	:	:	:	:	:	:	:	:	:	:	:	:	
	Green(253)	0	0	0	0	0	0	0	1	1	1	1	1	1	1	0	1	0	0	0	0	0	0	0	0
	Green(254)	0	0	0	0	0	0	0	1	1	1	1	1	1	1	1	0	0	0	0	0	0	0	0	0
Green(255)Bright	0	0	0	0	0	0	0	1	1	1	1	1	1	1	1	1	0	0	0	0	0	0	0	0	
Blue	Blue(000) Dark	0	0	0	0	0	0	0	0	0	0	0	0	0	0	0	0	0	0	0	0	0	0	0	0
	Blue(001)	0	0	0	0	0	0	0	0	0	0	0	0	0	0	0	0	0	0	0	0	0	0	0	1
	Blue(002)	0	0	0	0	0	0	0	0	0	0	0	0	0	0	0	0	0	0	0	0	0	0	1	0
	:	:	:	:	:	:	:	:	:	:	:	:	:	:	:	:	:	:	:	:	:	:	:	:	
	Blue(253)	0	0	0	0	0	0	0	0	0	0	0	0	0	0	0	1	1	1	1	1	1	1	0	1
	Blue(254)	0	0	0	0	0	0	0	0	0	0	0	0	0	0	0	1	1	1	1	1	1	1	1	0
Blue(255) Bright	0	0	0	0	0	0	0	0	0	0	0	0	0	0	0	1	1	1	1	1	1	1	1	1	



### 3.6 Power Sequences

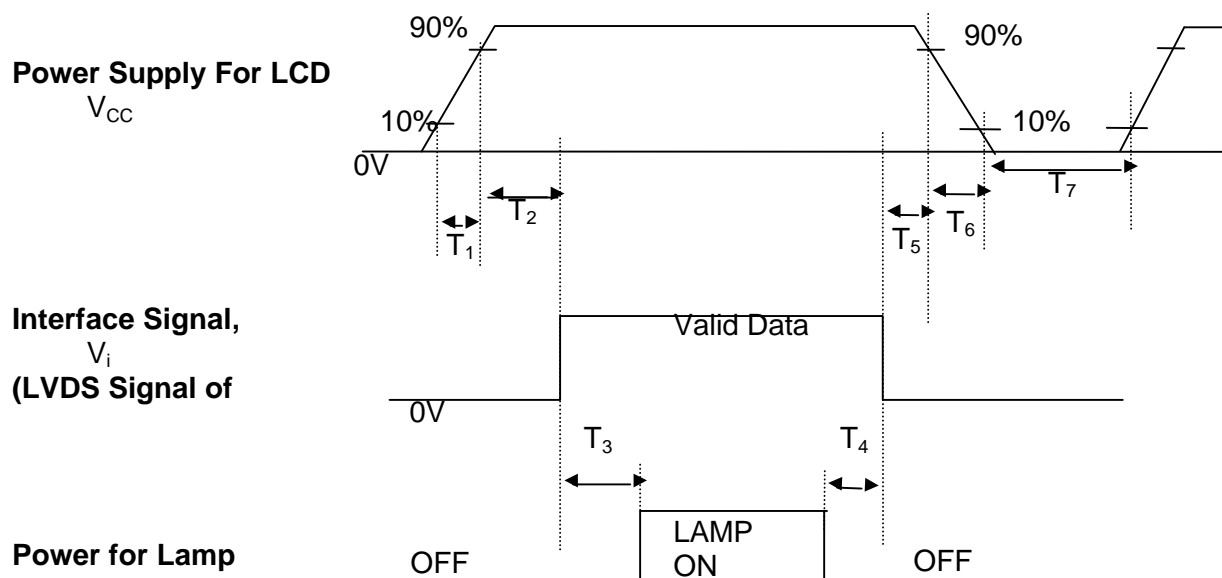

Parameter	Values			Units
	Min.	Typ.	Max.	
$T_1$	-	-	10	ms
$T_2$	0.01	-	50	ms
$T_3$	200	-	-	ms
$T_4$	200	-	-	ms
$T_5$	0.01	-	20	ms
$T_6$	0.01	-	10	ms
$T_7$	3	-	-	s

Note 1: Please avoid floating state of interface signal at invalid period.

Note 2: When the interface signal is invalid, be sure to pull down the power supply for LCD  $V_{CC}$  to 0V.

Invalid input with  $V_{CC}$  for a long time, cause permanent damage to LCD panel.

Note 3: Lamp power must be turn on after power supply for LCD and interface signal are valid.



**4. OPTICAL SPECIFICATIONS**

Optical characteristics are determined after the unit has been 'ON' and stable for approximately 30 minutes in a dark environment at 25 °C. The values specified are at an approximate distance 50cm from the LCD surface at a viewing angle of and equal to 0°.

Appendix A -1 presents additional information concerning the measurement equipment and method.

**Table 8. OPTICAL CHARACTERISTICS**

Parameter	Symbol	Values			Units	Notes
		Min.	Typ.	Max.		
Contrast Ratio	CR	200	250	-	-	1
Surface Luminance, white	L <sub>WH</sub>	170	200	-	cd/m <sup>2</sup>	2
Luminance Variation	WHITE			1.30	-	3
Response Time	Tr					4
Rise Time	Tr <sub>R</sub>	-	6	15	msec	
Decay Time	Tr <sub>D</sub>	-	19	30		
CIE Color Coordinates						
Red	x <sub>R</sub>	0.602	0.632	0.662		
	y <sub>R</sub>	0.321	0.351	0.381		
Green	x <sub>G</sub>	0.282	0.312	0.342		
	y <sub>G</sub>	0.546	0.576	0.606		
Blue	x <sub>B</sub>	0.120	0.150	0.180		
	y <sub>B</sub>	0.086	0.116	0.146		
White	x <sub>W</sub>	0.283	0.313	0.342		
	y <sub>W</sub>	0.299	0.329	0.359		
Viewing Angle						
x axis, right (F =0°)	x		+60	-	Degree	5
x axis, left(F =180°)	x		-60	-		
y axis, up(F =90°)	y		+45	-		
y axis, down (F =270°)	y		-45	-		
Gamma Value(reference value)			2.6			6
Crosstalk				2.5	%	7
Flicker			-23	-20	dB	8

Notes 1: Contrast Ratio (CR) is defined mathematically as :

$$\text{Contrast Ratio} = \frac{\text{Surface Luminance with all white pixels}}{\text{Surface Luminance with all black pixels}}$$

Note 2: Surface luminance is the center point across the LCD surface 50cm from the surface with all pixels displaying white. For more information see Appendix A - 2.

Note 3: The variation in surface Luminance,  $d_{\text{WHITE}}$  is determined by measuring  $L_{\text{ON}}$  at each test position 1 through 5, and then dividing the maximum  $L_{\text{ON}}$  of 5 points luminance by minimum  $L_{\text{ON}}$  of 5 points luminance. For more information see Appendix A - 2.

$$d_{\text{WHITE}} = \text{Maximum } (L_{\text{ON}1}, L_{\text{ON}2}, \dots, L_{\text{ON}5}) \div \text{Minimum } (L_{\text{ON}1}, L_{\text{ON}2}, \dots, L_{\text{ON}5})$$

Note 4: Response time is the time required for the display to transition from black to white (Rise Time,  $T_{\text{R}}$ ) and from white to black (Decay Time,  $T_{\text{D}}$ ). For additional information see Appendix A - 3.

Note 5: Viewing angle is the angle at which the contrast ratio is greater than 10. The angles are determined for the horizontal or x axis and the vertical or y axis with respect to the z axis which is normal to the LCD surface. For more information see Appendix A - 4

Note 6: Gray scale specification is as following.

Gray Level	Luminance (%) (min)	Luminance (%) (typ)	Luminance (%) (max)
L0	0.01	0.26	0.51
L31	0.37	0.97	1.57
L63	0.98	2.48	3.98
L95	3.93	6.83	9.73
L127	9.60	14.8	20.2
L159	19.5	29.3	39.1
L191	39.7	51.0	62.3
L223	62.7	72.9	83.1
L255	100	100	100

Note 7: Cross talk shall be measured at the V and H position. (Window size : 256 x 204 pixels)

$$\text{Crosstalk Ratio} = \frac{\text{Luminance at Pattern A} - \text{Luminance at pattern B}}{\text{Luminance at pattern B}} \times 100(\%)$$

For more information see Appendix A-5



Note 8: Flicker shall be measured at the center location.

Test pattern : Pixel pattern  
 Background RGB gray (0, 0, 0)  
 Foreground RGB gray (127, 127, 127)

$$\text{Test Equation} = 20 \log \frac{\text{AC(at 30Hz[ or 25Hz])}}{\text{DC level}}$$

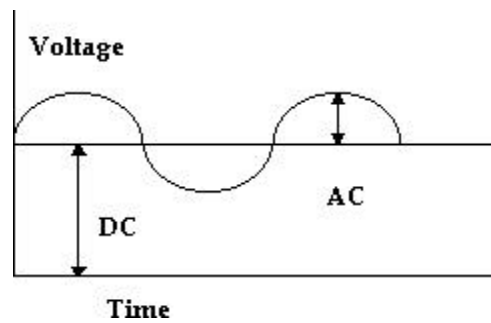

**5. MECHANICAL CHARACTERISTICS**

The chart below provides general mechanical characteristics for the model LM157E2-A2 LCD. In addition, the figure below is a detailed mechanical drawing of the LCD. Note that dimensions are given for reference purposes only.

Parameters	Value	unit	Notes
Outside dimensions Horizontal Vertical Depth	335 273.5 11.2	mm	-
Bezel area Horizontal Vertical	314.2 252.0	mm	-
Active Display area Horizontal Vertical	311.040 248.832	mm	-
Weight	1140(typ)	gram	-
Surface Treatment	Hard coating 3H. Anti-glare treatment of the front polarizer	-	-





< FRONT VIEW >

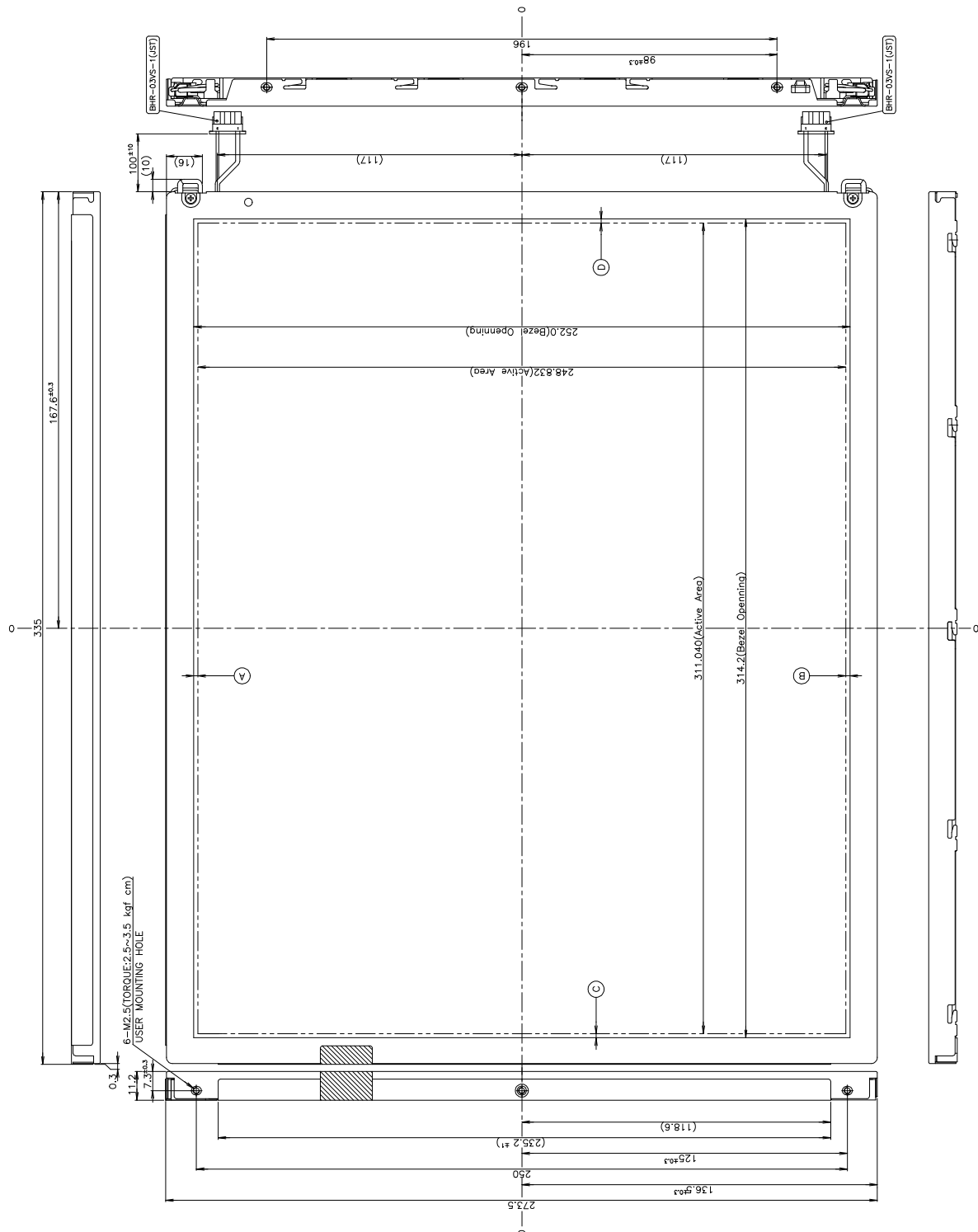

< REAR VIEW >

- NOTES**
1. Unspecified tolerances are to be  $\pm 0.5$
  2. This drawing is only preliminary data and can be changed without notice
  3. The gap between Top case and Glass is 0.5
  4. Tilt and partial disposition tolerance of display area are as following
    - 1) Y-Direction :  $IA-BI < 1.0$
    - 2) X-Direction :  $IC-DI < 1.0$

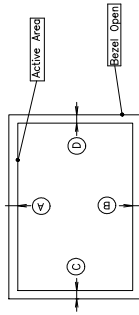

5. The same shape has the same dimension.

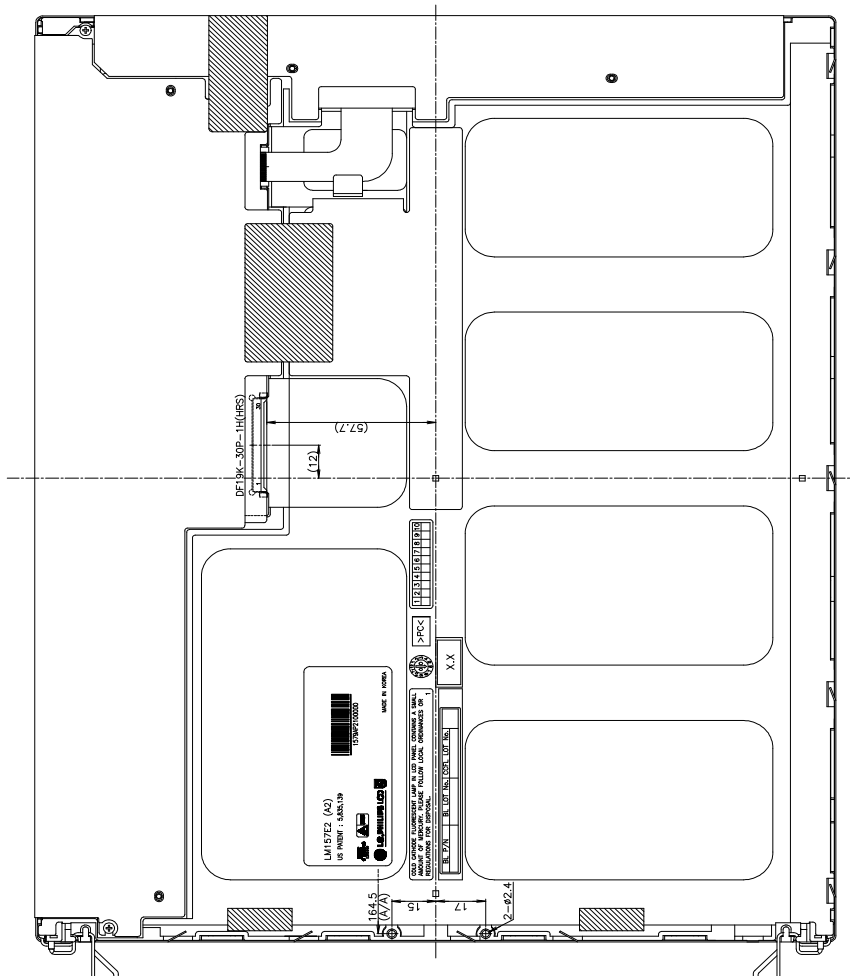

**6. RELIABILITY**

Environment test condition

No.	Test ITEM	Conditions
1	High temperature storage test	Ta = 60° 240h
2	Low temperature storage test	Ta = -20° 240h
3	High temperature operation test	Ta = 50° 50%RH 240h
4	Low temperature operation test	Ta = 0° 240h
5	Humidity Condition operation	20%RH ~ 80%RH
6	Humidity Condition storage	5%RH ~ 90%RH
7	Vibration test (non-operating)	Wave Form: Random Vibration Level: 1.0Grms Bandwidth: 10~500Hz Duration: 20min/Axis(X,Y,Z) One time each direction
8	Shock test (non-operating)	Shock Level: 120G Wave Form: Half Sine Wave, 2ms Direction: ±X, ±Y, ±Z, One time each direction
9	Altitude storage/shipment	0 - 53,300 feet

Result Evaluation Criteria

There should be no change which might affect the practical display function when the display quality test is conducted under normal operating condition.



## 7. INTERNATIONAL STANDARDS

### 7.1 Safety

- a) UL 1950 Third Edition, Underwriters Laboratories, Inc. Jan. 28, 1995.  
Standard for Safety of Information Technology Equipment Including Electrical Business Equipment.
- b) CAN/CSA C22.2 No. 950-95 Third Edition, Canadian Standards Association, Jan. 28, 1995.  
Standard for Safety of Information Technology Equipment Including Electrical Business Equipment.
- c) EN 60950: 1992 + A1 :1993 + A2 :1993 + A3 : 1995 + A4 : 1997 + A11 : 1997  
IEC 950 : 1991 + A1 : 1992 + A2 : 1993 + A3 : 1995 + A4 : 1996  
European Committee for Electrotechnical Standardization (CENELEC)  
EUROPEAN STANDARD for Safety of Information Technology Equipment Including Electrical Business Equipment.

### 7.2 EMC

- a) ANSI C63.4 "Methods of Measurement of Radio-Noise Emissions from Low-Voltage Electrical and Electronic Equipment in the Range of 9kHz to 40GHz." American National Standards Institute(ANSI),1992.
- b) C.I.S.P.R "Limits and Methods of Measurement of Radio Interference Characteristics of Information Technology Equipment." International Special Committee on Radio Interference (standards apply by CISPR22 Class-B)
- c) EN 55022 "Limits and Methods of Measurement of Radio Interference Characteristics of Information Technology Equipment." European Committee for Electrotechnical Standardization (CENELEC),1988



**8. PACKAGING**

**8.1 Designation of Lot Mark**

a) Lot Mark

A	B	C	D	E	F	G	H	I	J	K	L	M
---	---	---	---	---	---	---	---	---	---	---	---	---

A, B, C : INCH CODE

D : YEAR

E : MONTH

F, G : PANEL CODE

H : ASSEMBLY CODE

I, J, K, L, M : SERIAL NO.

Note 1: YEAR

YEAR	96	97	98	99	2000	2001	2002	2003	2004	2005	2006
Mark	6	7	8	9	0	1	2	3	4	5	6

Note 2: MONTH

MONTH	Jan.	Feb.	Mar.	Apr.	May	Jun.	Jul.	Aug.	Sep.	Oct.	Nov.	Dec.
Mark	1	2	3	4	5	6	7	8	9	A	B	C

b) Location of Lot Mark

Serial No. is printed on the label. The label is attached to the backside of the LCD module.

This is subject to change without prior notice.

**8.2 Packing Form**

a) Package quantity in one box : 8 pcs

b) Box Size : 344mm×315mm×410mm



## 9. PRECAUTIONS

Please pay attention to the followings when you use this TFT/LCD module.

### 9.1 MOUNTING PRECAUTIONS

- (1) You must mount a module user holes arranged in four corners.
- (2) You should consider the mounting structure so that uneven force (ex. twisted stress) is not applied to the module.  
And the case on which a module is mounted should have sufficient strength so that external force is not transmitted directly to the module.
- (3) Please attach the surface with a transparent protective plate in order to protect the polarizer LC cell.  
Transparent protective plate should have sufficient strength in order to resist external force.
- (4) You should adopt radiation structure to satisfy the temperature specification.
- (5) Acetic acid type and chlorine type materials for the cover case are not desirable because the former generates corrosive gas of attacking the polarizer at high temperature and the latter causes circuit break by electro-chemical reaction.
- (6) Do not touch, push or rub the exposed polarizer with glass, tweezers or anything harder than HB pencil head And Please do not rub with dust clothes with chemical treatment.  
Do not touch the surface of polarizer for bare hand or greasy cloth. (Some cosmetics are detrimental to the polarizer.)
- (7) When the surface becomes dusty, please wipe gently with absorbent cotton or other soft materials like chamois soaked with petroleum benzene. Normal-hexane is recommended for cleaning the adhesives used to attach front / rear polarizer. Do not use acetone, toluene and alcohol because they cause chemical damage to the polarizer.
- (8) Wipe off saliva or water drops as soon as possible. Their long time contact with polarizer causes deformations and color fading.
- (9) Do not open the case because inside circuits do not have sufficient strength.

### 9.2 OPERATING PRECAUTIONS

- (1) The spike noise causes the malfunction of circuits. It should be lower than following voltage :  
 $V = 200\text{mV}$  (Over and under shoot voltage).
- (2) Response time depends on the temperature. (In lower temperature, it becomes longer.)
- (3) Brightness depends on the temperature. (In lower temperature, it becomes lower.)  
And in lower temperature, response time (required time that brightness is stable after turned on ) becomes longer.
- (4) Be careful for condensation at sudden temperature change. Condensation makes damage to polarizer or electrical contacted parts. And after fading condensation, smear or spot will occur.



- (5) When fixed patterns are displayed for a long time, remnant image is likely to occur.
- (6) A module has high frequency circuit. If you need to shield the electromagnetic noise, please do co-work together.

### 9.3 ELECTROSTATIC DISCHARGE CONTROL

Since a module is composed of electronic circuits, it is not strong to electrostatic discharge. Make certain that treatment persons are connected to ground through wrist band etc...

And don't touch I/F pin directly.

### 9.4 PRECAUTION FOR STRONG LIGHT EXPOSURE

Strong light exposure causes degradation of polarizer and color filter.

### 9.5 STORAGE

When storing modules as spares for a long time. The following precautions are necessary.

- (1) Store them in a dark place. Do not expose the module to sunlight or fluorescent light. Keep the temperature between 5 °C and 35 °C at normal humidity.
- (2) The polarizer surface should not come in contact with any other object. It is recommended that they be stored in the container in which they were shipped.

### 9.6 HANDLING PRECAUTIONS FOR PROTECTION FILM

- (1) When the protection film is peeled off, static electricity is generated between the film and polarizer.  
This should be peeled off slowly and carefully by people who are electrically grounded and with well ion-blown equipment or in such a condition, etc.
- (2) The protection film is attached to the polarizer with a small amount of adhesive tape. If some stress is applied to rub the protection film against the polarizer during the time you peel off the film, the adhesive tape is apt to remain on the polarizer.  
Please carefully peel off the protection film without rubbing it against the polarizer.
- (3) When the module with protection film attached is stored for a long time, sometimes there remains a very small amount of adhesive tape still on the polarizer after the protection film is peeled off.
- (4) You can remove the adhesive easily. When the adhesive remains on the polarizer surface or its vestige is recognized, please wipe them off with absorbent cotton waste or other soft material like chamois soaked with normal-hexane.



10. APPENDIX

A-1 Optical Characteristic Measurement Equipment and Method

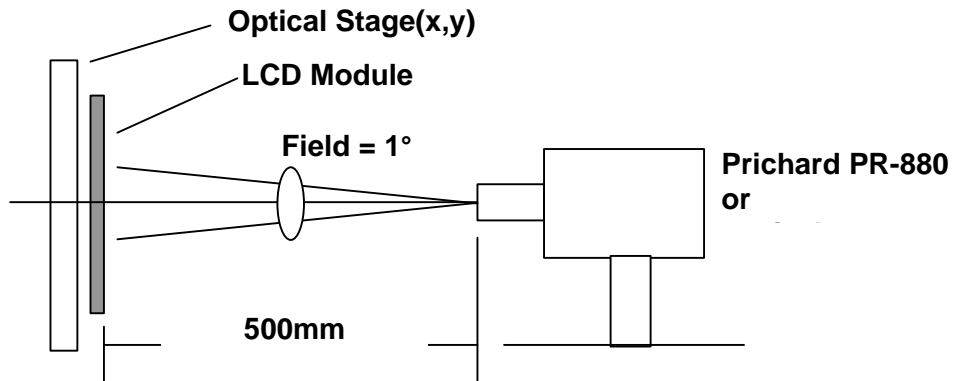

A-2 Luminance Measurement

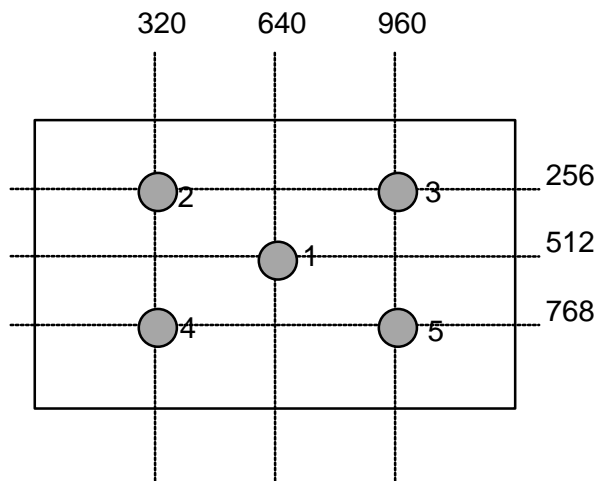

Measuring point for luminance variation & surface luminance

A-3 Response Time

The response time is defined as the following figure and shall be measured by switching the input signal for "black" and "white".

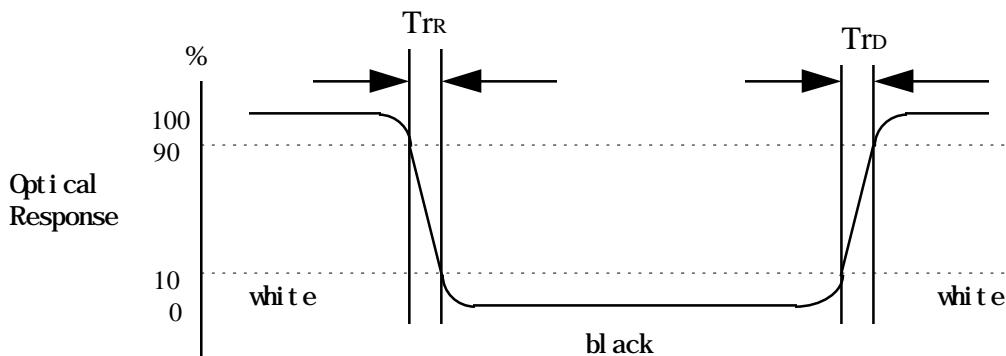



A-4 Viewing angle  
Definition of viewing angle range

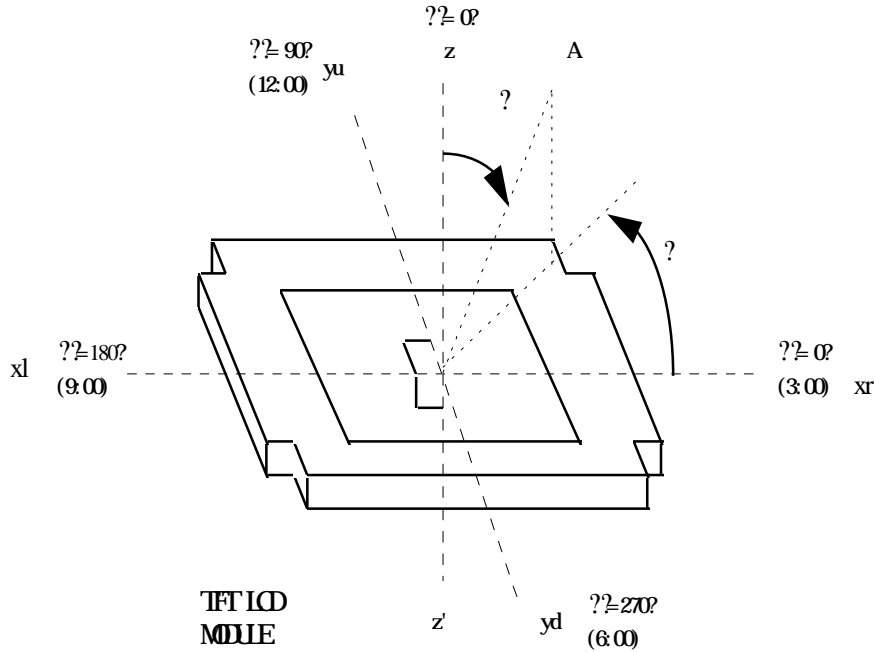

A-5 Crosstalk Measurement

Crosstalk:  $\left( \frac{L_{A[or C]2} - L_{A[or C]1}}{L_{A[or C]1}} \right) \times 100(\%)[vertical]$ ,  
 $\left( \frac{L_{B[or D]2} - L_{B[or D]1}}{L_{B[or D]1}} \right) \times 100(\%)[horizontal]$

$L_{A[or C]1}$ ,  $L_{B[or D]1}$ ,  $L_{A[or C]2}$ ,  $L_{B[or D]2}$  is luminance of pattern1,2 at position A, B, C, D

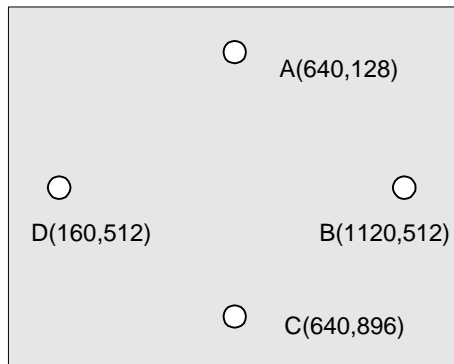

Pattern 1

Background : Mid-gray

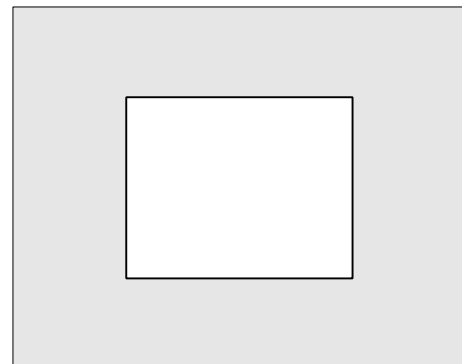

Pattern 2

Window : Black/White Window Size : 50%

